

# **Model 72**

## **Level Meter / Interface**

### **User Guide**

Issue 2, July 2004

This User Guide is applicable for serial numbers:  
M72-00151 and later

**Copyright © 2004 by Studio Technologies, Inc., all rights reserved**  
[www.studio-tech.com](http://www.studio-tech.com)

This page intentionally left blank.

# Introduction

The Model 72 Level Meter/Interface is a compact, portable device that plugs directly into an IFB or intercom circuit and provides two useful functions: audio level meters and line-level audio outputs. IFB (interruptible foldback) circuits are used in broadcast applications, providing one or two channels of talent cue audio. Intercom circuits are used by production personnel, supplying one or two channels of “party-line” communications.

Two 5-segment LED meters allow direct observation of the audio signal levels present on the connected IFB or intercom circuit. The display range is optimized for the signal levels found on typical “wet” (DC with audio) IFB and intercom circuits, rather than traditional “VU” scaling.

Two audio outputs provide transformer-coupled “dry” signals, one output associated with each IFB or intercom channel. These pro-audio-quality outputs are useful for a variety of production and testing applications. For example, the outputs can serve as the interface between a traditional “wet” IFB system and a wireless in-ear monitor or IFB system. The Model 72’s outputs can also be connected to line-level inputs on an audio console, allowing



View showing IFB/intercom input and power present LED indicator



View showing level meters and audio outputs

IFB or intercom audio signals to be combined and/or routed to other local or remote talent or production personnel cue systems. Other applications may arise where an amplified speaker needs to be used to monitor an IFB or intercom circuit. The Model 72’s audio outputs will make achieving this fast and simple.

Power for the Model 72 is provided by the connected IFB or intercom circuit. Active circuitry ensures accurate level metering and excellent audio performance. The compact device is housed in a rugged aluminum enclosure. All inputs and outputs interface using industry-standard 3-pin male and female XLR-type connectors. The connectors are manufactured by Neutrik® and feature gold-plated contacts and metal housings.

The Model 72 is compatible with virtually all single- and dual-channel IFB and intercom circuits used in broadcast, theatrical, and industrial applications. IFB circuits, typically provided by Studio Technologies’ IFB interface units or the RTS® 4000-series, can be directly connected. Industry-standard party-line intercom circuits are also compatible. Whether a single-channel system from Clear-Com® or a dual-channel TW-series system from RTS, direct connection to the Model 72 is supported.

The Model 72 provides both 3-pin male and female XLR-type connectors for direct interconnection with IFB and intercom circuits. The connector's pins are wired in parallel, allowing compatibility with interconnecting cables having male or female connectors. The two connectors can also serve as a "loop through" function. Pin 1 of the connectors is used as a common point for both DC power and audio signals. Pin 2 of the connectors is always used for DC power, typically in the range of 25 to 30 volts. With dual-channel IFB or intercom circuits pin 2 is also used to carry one of the two audio signals, typically designated as channel 1. (This audio signal is superimposed onto the DC voltage.) Pin 3 is always used to carry an audio signal but never DC power. In dual-channel IFB or intercom systems pin 3 typically carries channel 2 audio. In single-channel intercom systems pin 3 carries the one and only audio signal.

The Model 72 was developed out of necessity, once again proving that the old saying is correct; necessity was definitely the "mother" when it came to the unit's invention. The genesis was very simple. Often when testing audio equipment out "in the field," Studio Technologies personnel felt "blind" when interfacing with IFB and intercom circuits. Typically it was difficult to obtain "clean" balanced line-level audio signals, and never possible with a nominal level approaching +4 dBu. Worse yet, confirming the signal levels of an IFB or intercom circuit was virtually impossible. It often seemed that the signal levels were either too low or too "hot," but there was no simple way available to establish that fact. With the Model 72 these problems should disappear. Monitoring of the audio

levels is clear and accurate, and balanced line-level outputs are directly available.

## Operation

The only action required for initial operation of the Model 72 is connecting an IFB or intercom circuit. If the audio outputs are going to be utilized interconnecting cables must also be connected. No external power source is necessary and the unit contains no configuration switches or user controls.

## Connecting an IFB or Intercom Circuit

Two 3-pin XLR-type connectors, one male and one female, are associated with the Model 72's IFB/intercom input. The three pins on each connector are wired in parallel, allowing the mating connector on the interconnecting cable to be of either gender. In addition to providing interfacing flexibility, the two connectors can be used in a loop-through arrangement. This may eliminate the need in some applications to use a "Y" or splitter cable.

The connected IFB or intercom circuit must have common on pin 1, DC power (and possibly audio) on pin 2, and audio on pin 3. For correct Model 72 operation the DC power on pin 2 must be within the range of 22 to 32 volts and capable of supplying 42 milliamperes of current. Once an IFB or intercom circuit is connected the red LED, labeled PIN 2 POWER, should light.

## Level Meters

Any time that an IFB or intercom circuit is connected to the Model 72 the two 5-segment LED meters will be active.

They display the level of audio signals present on pins 2 and 3 of the connected circuit. The meters are calibrated to clearly display the signal levels found on typical IFB and intercom circuits. The meters display the actual signal levels that are present on the pins in dBu. (This relates to the voltage level, in dB, as referenced to 0.775 volts RMS.) The ballistics of the meter is a cross between that of a VU and a peak (PPM) meter. (We affectionately refer to it as a “PU” meter!) The way the LEDs “move” in response to signals should be comfortable for most users to observe.

Green LEDs are used to display the meters’ lowest four level steps. They light to indicate signal levels that are typically present on a correctly functioning IFB or intercom circuit. The LED that displays the highest value on the meter scale (–4 dBu) is yellow in color, indicating that a relatively “hot” signal is present. While not necessarily a problem, having the yellow LED lighting steadily would typically indicate a signal level that may be of concern.

## Audio Outputs

Two transformer-balanced line-level audio outputs are provided. One output is associated with the audio signal that may be present on pin 2 of the connected IFB or intercom circuit. The other output is associated with the audio signal that is present on pin 3 of the connected circuit. Whether signal is available on both audio outputs will depend on the type of IFB or intercom circuit that is connected. The actual level on the audio outputs is 14 dB above its source, i.e., there is 14 dB of input-to-output gain. This was selected so that connecting a typical IFB or intercom

circuit that has a nominal level of –10 dBu will result in a +4 dBu nominal level on the audio output connectors.

Each audio output is connected to external devices using a 3-pin male XLR-type connector. Mating connectors (females) should be prepared so that signal high (+ or hot) is on pin 2 and signal low (– or cold) is on pin 3. The cable’s shield can be connected to pin 1, but it will have no function. To limit the chance of grounding interaction between the Model 72 and connected equipment, the pin 1 connections on both audio output connectors are isolated from any point in the Model 72. The fact that pin 1 “floats” will minimize the chance of hums, noise, or buzzes being present on the equipment connected to the main output.

For full electrical isolation, the audio outputs are transformer isolated. To provide protection against accidental connection to cables that have DC power present, the audio outputs are also capacitor coupled. In series with the output leads are 300 ohm resistors, making the effective output impedance 600 ohms. These resistors serve several purposes. They will limit the maximum amount of output current that can be drawn in the event of a cable short. In addition, they allow multiple audio outputs to be connected together, creating a passive summing network. By using a simple “Y” cable the two audio outputs can be passively summed. A side effect from using this passive summing technique is that signal attenuation will occur. The audio quality won’t suffer, but this passive summing method does create an audio “pad.” If the two audio outputs are connected together a signal attenuation of 6 dB can be expected.

# Technical Notes

## Channel Assignments

By design, the Model 72 doesn't define what signals will be present on the pins of the connected IFB or intercom circuit. This is because of the many different ways signals and signal names can be assigned to the same type of circuit. For universality, the meters and audio outputs are referenced to the pins on the IFB/intercom input, rather than having assigned names. This naming method leads to one level meter and one audio output being associated with pin 2. The second meter and audio output is associated with pin 3. For reference it may be worthwhile to list some standard pin assignments:

- In broadcast IFB applications pin 2 is often defined as the "interrupt" or the "program-with-interrupt" channel. It may also be referred to as IFB channel 1. Pin 3 is often defined as "program" or "program-only." It may also be referred to as IFB channel 2.
- Many broadcast applications use TW-type intercom systems from RTS. In these cases pin 2 will be intercom channel 1; pin 3 will be intercom channel 2.
- Often theatrical and industrial applications use single-channel intercom systems from Clear-Com. In these cases pin 2 will only provide DC power, having no audio source associated with it. Pin 3 will provide intercom audio or intercom channel 1.

## Power LED and Input Voltage

It's important to note that the LED labeled PIN 2 POWER will light essentially any time a positive DC voltage is present on pin 2 of either of the IFB/intercom input connectors. Any DC that's above approximately 3 volts is sufficient to light the LED. This is by design as the LED is really just intended to indicate that a "wet" circuit has been connected. For full Model 72 operation the DC input needs to be in the range of 20 to 22 volts.

## IFB Audio Levels

The nominal level of audio signals associated with IFB circuits is typically  $-10$  dBu. This is the case with the interface units from Studio Technologies, as well as such systems as the RTS 4000-series. But actually having the correct level present on an IFB circuit is often a "hit-or-miss" proposition. During field testing Studio Technologies' personnel found that a wide range of nominal audio levels were present on "real-world" IFB circuits. Many were fine, being reasonably close to the desired  $-10$  dBu. But some were much too low, while others were much too "hot." We observed one unfortunate baseball "color" commentator being sent interrupt audio signals so "hot" relative to program audio as to almost make his ears bleed! This situation should not have been allowed to happen.

In defense of field technical personnel, measuring the audio level of an IFB circuit hasn't traditionally been an easy proposition. But that situation has now changed with the Model 72. Using the unit will allow level controls on the source equipment to be adjusted as required.



## Intercom Audio Levels

In North America the two most common intercom systems are those from RTS and Clear-Com. From tests performed in Studio Technologies' lab the nominal RTS TW-series audio level was approximately  $-10$  dBu. The dynamic range control provided by belt-packs such as the MP-325 was very good, limiting the maximum level to at most 10 dB above the nominal. The nominal audio level associated with a single-channel Clear-Com system was harder to characterize. It appeared to be a few dB less than  $-10$  dBu, but with a much larger dynamic range. Level peaks of 10 to 20 dB over nominal were easy to produce.

The contents of this section, along with the previous one, may elicit howls of protest from a host of engineers and intercom-system experts. But for years we've heard differing reports as to the actual nominal audio levels for RTS and Clear-Com systems. The "in-the-know cats" agreed that the nominal level of RTS TW-series intercom (and 4000-series IFB) was  $-10$  dBu, a value that we confirmed in our tests. But the nominal level for Clear-Com party-line systems was variously reported as  $-20$ ,  $-15$ ,  $-12$ ,  $-10$ , and "you know, the Clear-Com level!" It's most likely that early Clear-Com systems did use a nominal level in the  $-20$  dB range. But after making controlled tests, their contemporary equipment seemed to be much closer to  $-10$  dBu. And with the limited dynamic-range control that we experienced, the actual level during operation may vary widely.

In conclusion, the engineers at Studio Technologies are always open to learning more. Additional information from the field concerning IFB and intercom system levels would be welcomed. Stopping by our offices for an in-person chat would be also great. (And bringing along pizza and beer for a tech-talk session would certainly get our attention!) Just park the production trailers on the street!

# Specifications

## **General Audio:**

**Frequency Response:** 20 Hz-20 kHz,  $\pm 0.5$  dB

**Distortion (THD+N):** 0.02%, measured at 1 kHz,  
-10 dBu in/+4 dBu out

**S/N Ratio:** 93 dB, referenced to -10 dBu in/  
+4 dBu out

## **Connectors:**

**IFB/Intercom Input:** 3-pin male and female  
XLR-type

**Audio Outputs:** 3-pin male XLR-type

## **IFB/Intercom Input:**

**Type:** single- or dual-channel, unbalanced (pin 1  
common; pin 2 DC (or DC with audio); pin 3 audio)

**Impedance:** 20 k ohms, nominal

**Level:** -10 dBu, nominal

**Compatibility:** virtually all single- and dual-channel  
IFB and intercom circuits

## **Audio Outputs:**

**Type:** balanced, transformer-coupled with series  
capacitors and isolation resistors

**Impedance:** 600 ohms, nominal

**Nominal Level:** +4 dBu, measured with -10 dBu  
IFB/intercom input level

**Maximum Level:** +16 dBu into 2 k ohms

**Gain:** 14 dB, input-to-output

## **Power Requirement:**

22-32 Vdc, 42 mA (provided by IFB/intercom input)

## **Dimensions (Overall):**

4.2 inches wide (10.7 cm)

2.0 inches high (5.1 cm)

4.7 inches deep (11.9 cm)

**Weight:** 0.8 pounds (0.35 kg)

Specifications and information contained in this  
User Guide subject to change without notice.



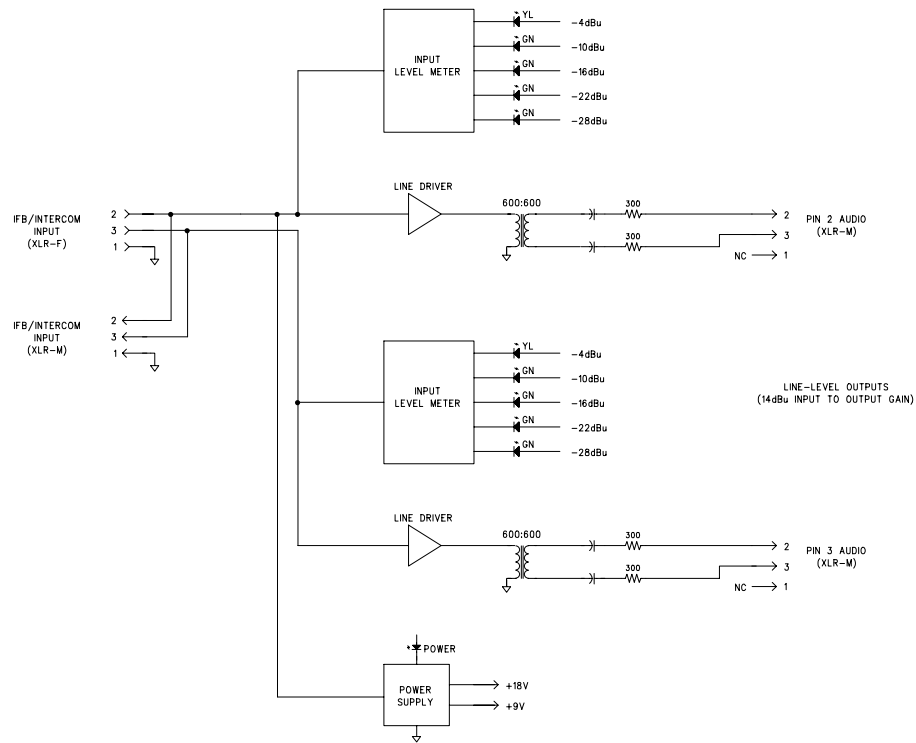

M72BD\_A

STUDIO TECHNOLOGIES, INC.

MODEL 72 LEVEL METER / INTERFACE  
BLOCK DIAGRAM