

Model 5152

Video Generator/Audio Embedder Module

User Guide

Issue 5, September 2013

**This User Guide is applicable for
Model 5152 modules with the following order codes:
M5152, M5152-01, M5152-02, M5152-03X, and M5152-04X
with serial numbers 00151 and later
and firmware versions
MCU 2.3 and later (m5152.s19) and FPGA 2.2 and later (m5152.bit)**

Copyright © 2013 by Studio Technologies, Inc., all rights reserved
www.studio-tech.com

This page intentionally left blank.

Table of Contents

Introduction.....	5
Installation	9
Configuration	14
Operation.....	22
Technical Notes	27
Specifications	34
Appendix A—Model 5152 Versions	35
Appendix B—DC Input/Data and GPI/GPO Interconnection Details	36
Appendix C—Model 5152 Front Panel and Printed Circuit Board (PCB) Dimensions.....	38

This page intentionally left blank.

Introduction

The Model 5152 Video Generator/Audio Embedder Module is a unique device suited for a variety of custom broadcast, post-production, industrial, and corporate multimedia installations. As a member of the 5100-Series of modules, the Model 5152's compact size belies its powerful video and audio feature set. At its most basic, the Model 5152 provides the ability to embed up to eight audio channels (four AES3 digital audio "pairs") into a SMPTE®-compliant HD- or 3G-SDI video "stream." Unlike most stand-alone embedder products, Model 5152 embedding operation does not require an external source of SDI to be connected. Advanced circuitry within the Model 5152 supports the generation of a broadcast-standard high-definition SDI signal. And rather than reproducing a fixed test pattern, the Model 5152 has the capability to store and output two custom video images. The images, one for "720" and one for "1080," are based on bitmap (.bmp) files that can be created using a personal computer's graphics program.

For convenience, the .bmp files are stored in the module's nonvolatile memory via a standard USB flash drive. The appropriate "720" or "1080" image is automatically connected to the SDI output whenever an SDI input signal is not present. This ensures

that an SDI output signal is always sent to equipment further along the signal chain.

The Model 5152's video signal generation capability can be extremely useful, serving as both a "keep-alive" signal as well as allowing a detailed graphics image to be displayed for identification purposes. When a valid HD- or 3G-SDI signal is connected to the module's input it will pass through, unchanged, to the module's SDI output. Only when an input is not present will the stored image be generated. The format and rate of the stored image will match that of the previously-connected SDI input signal. This "learning" capability allows a Model 5152 to automatically adapt to the SDI format and rate utilized by a specific facility or application.

An alternate operating mode can be selected, allowing the Model 5152 to serve as a dedicated video signal generator. In this mode an SDI signal connected to the module will serve as an external timing reference.

General Highlights

Applications for the Model 5152 include sports broadcasting booth packages, "POV" (point-of-view) remote-controlled camera systems, stadium audio/video interface (I/O) locations, and government/

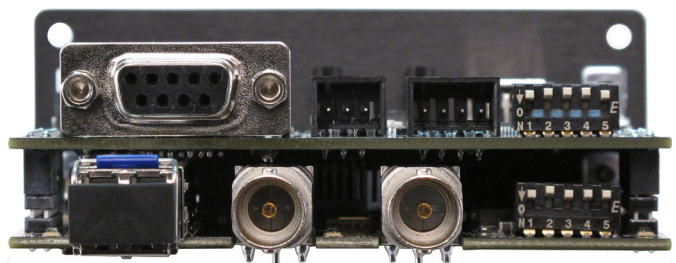
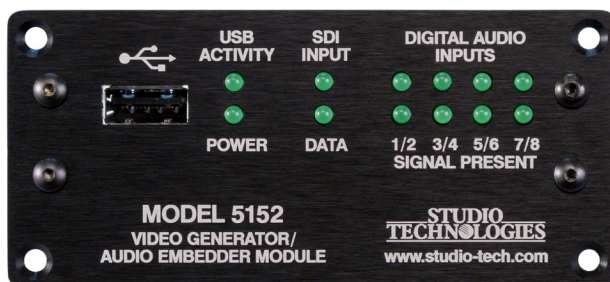

Figure 1. Model 5152 Video Generator/Audio Embedder Module front and rear views

corporate facilities. The module's performance is completely "pro" with video and audio quality, reliability, and installation flexibility matching that of much larger-scale equipment.

For operation the Model 5152 only requires connection of a few signals. These consist of SDI inputs and outputs, up to four unbalanced digital audio sources, an external source of nominal 12 volts DC and, optionally, two wires associated with a local RS-485 data bus. Some applications may also utilize the general-purpose input (GPI) and general-purpose output (GPO) functions (available only on modules with serial numbers 00251 and later). Coaxial SDI input and output support is standard. Optical input and output support is optional. The acceptable DC input voltage range is 10 to 18, allowing a variety of power sources to be utilized.

The Model 5152 uses standard connectors for fast, convenient interfacing. Coaxial SDI input and output signals use BNC connectors. An optional video SFP fiber optic module can be installed at the factory. The module supports interconnection of single-mode optical fibers using LC plugs. Digital audio signals interface with the Model 5152 by way of a 9-pin D-subminiature connector. The DC power input and data bus connections use a 4-position, 0.1-inch header. The GPI and GPO connections use a 3-position, 0.1-inch header. Low-cost IDC (insulation-displacement connector) mating sockets allow simple interconnection with a variety of wire gauges. Twelve status LEDs offer users both performance confidence and troubleshooting assistance.

The Model 5152 is compatible with the Studio Technologies' Model 5190 Remote Access Module. This will allow remote

configuration, monitoring and control, via an Ethernet connection, of key module operating and status parameters. A local RS-485 data bus allows up to 16 of the 5100-Series modules to be connected to a Model 5190.

Several Model 5152 operating parameters can be configured to meet the needs of specific applications. A USB flash drive along with several DIP switches, are used to convey the configuration to the module. A simple text file that reflects the desired configuration is created and stored on the USB flash drive. When inserted into the appropriate socket on the Model 5152 the file is read and stored. Updating the Model 5152's firmware (embedded software) is also possible using a USB flash drive loaded with factory-supplied files.

Model 5152 Video Generator/Audio Embedder Modules do not include a mounting enclosure or chassis. They are intended for mounting in custom 19-inch rack panels, equipment boxes, broadcast furniture, "NEMA" I/O boxes, or other specialized enclosures. It is expected that integration firms will create applications that use Model 5152 modules as part of complete broadcast, production, corporate, and government solutions. Sophisticated users will be able to easily create "one-off" solutions to solve unique challenges.

SDI Inputs and SDI Outputs

High-definition SMPTE-compatible SDI signals with data rates of 1.485 Gb/s nominal (HD-SDI) and 2.97 Gb/s nominal (3G-SDI) can be connected. Virtually all of the commonly-utilized "720" and "1080" formats are supported. Standard-definition SDI signals with a data rate of 270 Mb/s nominal (SD-SDI) are not supported. It was felt that users looking for advanced solutions such as

those provided by the Model 5152 will not typically be working with SD-SDI signals. But be assured that many HD-SDI and 3G-SDI formats and rates are supported, allowing the Model 5152 to be appropriate for worldwide use.

Coaxial (BNC) Support

Using standard BNC connectors, the Model 5152 supports one coaxial SDI input and one coaxial SDI output.

Optical Fiber Support

Factory-implemented options allow the Model 5152 to support SDI signals that are transported using single-mode optical fibers. Using video SFP modules a range of optical input, output, and transceiver capabilities can be supported. For a list of available Model 5152 versions refer to Appendix A.

The standard 1310 nanometer optical transmit wavelength is available, as are the more-esoteric CWDM wavelengths. A module that includes an optical SDI output will always have its optical output active, transporting the same SDI data as that present on the coaxial (BNC) output. When a Model 5152 has been provided with an optical SDI input a configuration choice selects whether it, or the coaxial (BNC) input, is active.

Video Generation Capability

During typical operation an HD- or 3G-SDI signal is connected to the Model 5152's selected SDI input. It's then "passed through" to the module's SDI output(s) and on to the next part of the signal chain. But what happens when the external SDI signal is not present? That's when the Model 5152's internal SDI generator becomes active. When a signal is not present on the selected SDI

input the module will generate a high-definition (HD- or 3G-SDI) image that will serve as a "slate," ID, or "SDI-active" signal. This SDI signal also allows the audio embedding function to remain active.

From the factory two bitmap (.bmp) image files are stored in nonvolatile memory. One file is used for generating the image for 1280 x 720 pixel formats and the other for 1920 x 1080 pixel formats. But alternate bitmap image files can be created and stored in the Model 5152. These alternate images can supply site- or application-specific information useful to "downstream" users. Using a personal-computer graphics program, such as Microsoft® Paint® or Adobe® Photoshop®, generating custom images and storing them in the appropriate bitmap format is a simple matter.

A USB port, located on the Model 5152's front panel, allows direct connection of a standard USB flash drive. If the Model 5152's firmware (embedded software) recognizes compatible FAT32 bitmap (.bmp) files on the USB flash drive they will be automatically loaded into nonvolatile memory. The USB flash drive can then be removed with the custom images safely stored within the Model 5152.

One subtle but important configurable feature has been included for broadcast applications which use the Model 5152's SDI output(s) "on-air." When an SDI signal is removed from the module's selected SDI input, the Model 5152 can be configured to output a few seconds of solid-gray color before the stored image appears. This will help to ensure that technicians or operators will be visually "warned" that the module's input signal has been lost and that the stored image will soon be taking its place. It's hoped that the solid-gray video

image will be innocuous for on-air viewers yet different enough to encourage operators to switch the module's output away from being "on air."

A unique feature of the Model 5152 is its ability to automatically adapt to the format and rate of a connected SDI signal. This allows the stored image to be output at the same format and rate as that used by the associated network, local facility, or event. If, for example, a connected input is "1080i/59.94" then the Model 5152 will automatically detect and store that information. From then on whenever an SDI input signal is not present the internal generator will output the stored image at "1080i/59.94." Changing the format and rate of the generator only requires connection of an SDI signal with the desired characteristics. (A minimum required connection time helps to ensure that an accidental format/rate change won't occur.) However, there may be situations where maintaining the format and rate of the internally-generated signal is important. To support this condition one configuration choice allows the automatic format/rate selection function to be disabled.

Video Generation with External Reference

Some applications may benefit from the Model 5152 serving as a full-time stand alone video generator. A configuration choice helps to support such applications by using the selected SDI input only as a timing reference. Unlike typical operation, when selecting this operating mode a signal connected to the selected SDI input would not pass through to the SDI. Its rate, format, and specific timing characteristics would be used as a reference for the internally-generated video output. Note that bi-level or

tri-level analog timing reference signals are not supported. Only a HD-SDI or 3G-SDI signal can serve as a reference signal for the Model 5152.

Audio Embedding

The Model 5152 allows four stereo digital audio signals to be embedded into the SDI output signal. The eight channels of audio will always be embedded, whether or not an SDI source is connected to the module. Nine configuration choices allow flexibility as to where the digital audio inputs will be embedded into the SDI output signal. A range of applications can be supported by taking advantage of the module's ability to embed into groups 1, 2, 3, or 4.

The four digital audio inputs are 75 ohms, unbalanced, and follow the AES3 standard. They are intended for use with broadcast-standard "24-bit, 48 kHz" digital audio signals. Advanced sample-rate-converter circuitry ensures excellent performance with signals that are asynchronous with each other and the Model 5152's internal timing.

The Model 5152's digital audio inputs are directly compatible with the digital audio output provided by the Studio Technologies' Model 5110 Mic/Line Input Module. Up to four Model 5110 modules can be directly connected, supporting eight mic/line inputs.

A major Model 5152 feature is its ability to embed audio into the SDI output signal whether or not an SDI input signal is present. If a valid SDI signal is connected then the Model 5152 will embed audio data into that data stream. If an SDI signal is not connected embedding will continue but now will be associated with the custom image. In this way embedded-audio transport will always be supported.

When audio is being embedded into an externally-connected SDI signal it will replace any incoming embedded audio that's already present. However, any embedded audio present on groups that are not being embedded by the Model 5152 will correctly "pass through" to the SDI output. This is important when SDI input signals that already include embedded audio, such as from portable ENG-type cameras, are connected. Such devices typically embed two or four microphone audio channels into group 1, which need to pass through the Model 5152 without interference.

It's important to note that when changing from an external SDI signal to the internal generator (or vice-versa) the SDI output, including embedded audio, will momentarily lose timing and some video and audio "glitches" may be present. For the intended Model 5152 applications this should not prove to be an issue but is worth mentioning.

GPI and GPO

Model 5152 modules with serial numbers 00251 and later offer a general-purpose input (GPI) and a general-purpose output (GPO) function. The GPI allows the connection of a switch or contact closure to control the on/off status of the Model 5152's audio embedder function. Future versions of the Model 5152's firmware may implement other GPI-controlled actions.

The GPO function provides an indication of the status of the selected SDI input. It's intended that the GPO will be connected to an LED indicator. A configuration choice selects whether the GPO is active (+3.3 volts) when the selected SDI input is valid or active when the selected SDI input is invalid. (This can also be described as

active "high" or active "low"). This allows, for example, a green LED to light whenever a valid signal is connected to the selected SDI input, thus providing an "input good" indication. Alternately, a red LED could light when the selected SDI input is not active, providing an "input fail" indication.

Installation

Integration of the Model 5152 into a selected application should prove quite simple, only connecting SDI input and output signals, digital audio sources, as well as DC power is required. Some applications will also require connection to the module's data bus, GPI, and GPO functions. The coaxial (BNC) input and output connections are compatible with most HD-SDI and 3G-SDI signals. If the specific Model 5152 being installed also includes optical support one or two single-mode fiber interconnections will be made. The fiber connections utilize miniature LC plugs.

Up to four AES3-compliant unbalanced digital audio signals can be connected by way of a 9-pin D-subminiature (DE-9) connector. Each of these four digital audio signals supports two channels of audio.

The DC power source is nominal 12 volts with an acceptable range of 10 to 18 volts. It's possible that the module will be part of a local RS-485 data bus that's associated with a Studio Technologies' Model 5190 Remote Access Module. If so, two additional wires are required to connect the module to the data bus. GPI and GPO connections are made using a 3-pin header. After all the connections have been completed the module can then be secured into the designated mounting location.

Coaxial (BNC) SDI Output

The Model 5152 provides an SDI output that utilizes a broadcast-standard BNC socket. This output is referred to as the coaxial (BNC) SDI output. Refer to Figure 2 for a detailed view of the connector's location on the rear of the module. The coaxial (BNC) output, depending on operating conditions, will be either a SMPTE-compliant HD-SDI (1.485 Gb/s nominal) or a 3G-SDI (2.97 Gb/s nominal) signal. The exact format/rate combinations supported by the Model 5152 are listed in the Specifications section of this guide.

Coaxial (BNC) SDI Input

An SDI source can be connected to the Model 5152 by way of a broadcast-standard BNC connector. This is referred to as the coaxial (BNC) SDI input. Refer to Figure 2 for a detailed view of the connector's location on the rear of the module. The coaxial (BNC) input is compatible with SMPTE-compliant HD (1.485

Gb/s nominal) and 3G (2.97 Gb/s nominal) SDI signals. It is not compatible with standard definition SD-SDI (270 Mb/s nominal) signals. The exact format/rate combinations supported by the Model 5152 are listed in the Specifications section of this guide.

A configuration setting must be made for the coaxial (BNC) SDI input to be active. Refer to the Configuration section of this guide for details.

Optical SDI Output

This section applies only when the specific Model 5152 module being installed was configured at the factory to provide an optical output. A video SFP (small form-factor pluggable) optical module is used to provide the optical SDI output. A range of SFP modules can be installed in the "cage" at the back of the Model 5152. These include transceiver modules that have both an optical output (transmitter) and an optical input (receiver), as well as output-only (transmitter) modules. The technical characteristics of the optical

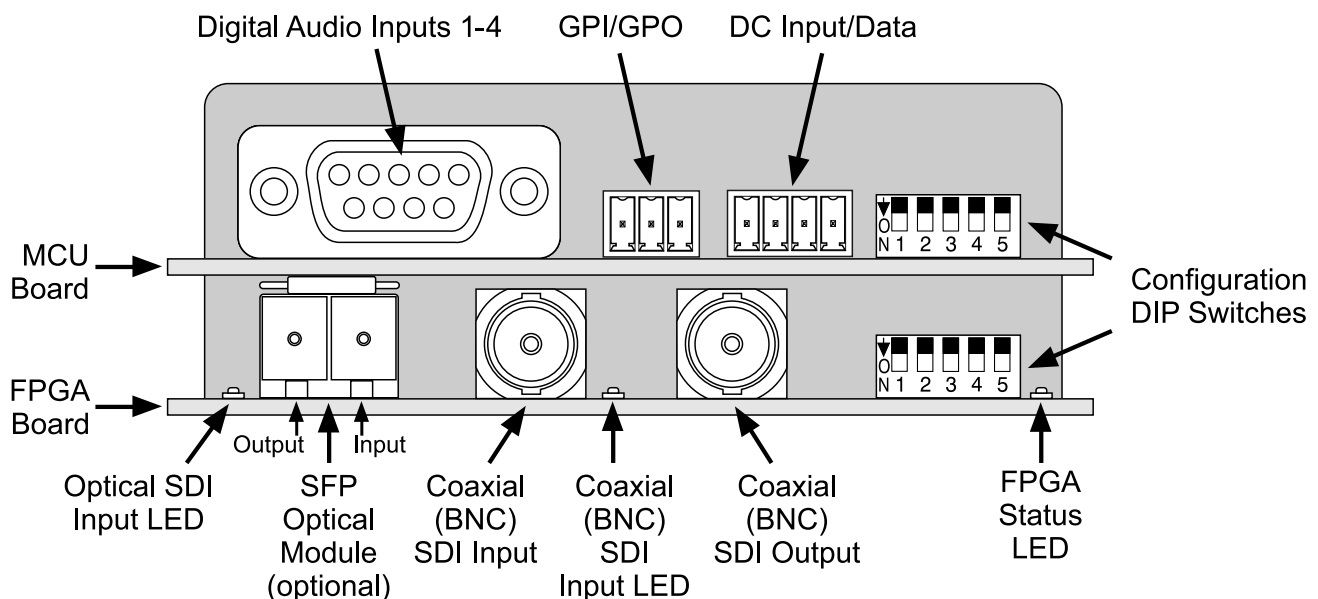

Figure 2. Detailed rear view of the Model 5152 Video Generator/Audio Embedder Module showing the MCU and FPGA boards

output will depend on the specific module installed. The most common transceiver or output-only SFP module used in the Model 5152 will have an FP (Fabry-Perot) laser emitting “light” at a wavelength of 1310 nanometers. Other modules can utilize a higher-performance DFB (distributed feedback) laser that is manufactured to produce light at one of the 18 CWDM wavelengths. (For broadcast applications, the common first-utilized CWDM wavelengths are often 1490 and 1550 nanometers.)

An LC plug terminated on a single-mode optical fiber is used to mate with the SFP’s optical output. When referenced to the front of an SFP transceiver or output-only SFP module the optical output is located on the SFP module’s left side. To indicate the optical output port a graphic arrow icon pointing “out” may be present on the top of the module. Refer to Figure 2 for a detailed view. When terminating the LC plug with the socket on the SFP module be certain that the plastic plug’s locking tab is fully engaged into the slot of the SFP module. This will help prevent the LC plug from becoming disconnected due to physical stress or vibration on the fiber. Also ensure that the end (“face”) of the plug’s ferrule has been cleaned using appropriate methods.

Note that as of the time this user guide was written the Model 5152 supports only single-mode optical cable. Contact Studio Technologies should support for multi-mode fiber be required.

The Model 5152 module should remain without power whenever its optical output has not been terminated. This ensures that the optical energy will not project into free space and possibly into the eyes of installation personnel. The optical output power of video SFP modules selected by Studio

Technologies adheres to the class 1 laser standard. As such, they do not emit sufficient power to be considered hazardous. But best safety practices require that the optical output port and all unconnected fiber ends not be directly viewed.

No configuration setting is required to activate the optical output. It is always active and will contain the same SDI data as that found on the coaxial (BNC) output. As such there is no problem in simultaneously connecting to both the optical and coaxial (BNC) outputs.

Optical SDI Input

If supported by the specific Model 5152 module being installed, an HD- or 3G-SDI signal transported on a single-mode optical fiber can be connected. For an input to be present a video SFP transceiver or a receive-only SFP module must have been installed in the SFP “cage” in the back of the unit. The optical receiver circuitry in an SFP module is “broadband” and doesn’t need to receive a specific wavelength of single-mode optical signal for correct operation. As long as the optical signal has a wavelength between 1250 and 1650 nanometers and meets the applicable SMPTE standards it will be recognized correctly.

A single-mode optical fiber terminated with an LC plug can be connected to the receive port on the SFP module. This port is on the right side when looking directly at the back of the SFP module. Typically there will be a graphic arrow icon pointing “in” on the top of the module. Refer to Figure 2 for details on the location of the SFP module. Ensure that the LC plug fully “mates” with the receive port and its tab is locked into the slot of the SFP module.

A configuration setting must be appropriately made to enable the optical SDI input. There is no automatic switching between the optical and coaxial (BNC) SDI inputs. Only one of the two SDI inputs can be selected and active at a time. Refer to the Configuration section of this guide for details.

Digital Audio Inputs

Up to four unbalanced digital audio sources can be connected to the Model 5152. Following SMPTE standards, they will be embedded into the externally-supplied or internally-generated SDI signal. The four serial digital audio sources represent eight audio channels, two per serial digital audio signal. The sources must comply with the AES3 standard for unbalanced digital audio signals. These have a characteristic impedance of 75 ohms and a nominal signal level of 1 volt peak-to-peak. This type of signal was previously referred to as being an AES3id digital audio signal.

The connected signals do not have to be synchronized with each other or with the associated SDI input and output signals. This is because each of the Model 5152's digital audio input circuits has a sample-rate-conversion (SRC) function associated with it. Digital audio signals with a sample rate of 32 to 48 kHz and a bit depth of up to 24 are compatible. The nominal reference signal level of the connected digital audio source can follow either the AES (–20 dBFS) or EBU (–18 dBFS) standard. This is because the embedding function simply takes the incoming digital audio “bits” and inserts them into the correct data locations in the SDI signal.

An interconnecting cable assembly must be prepared with a 9-pin male D-subminiature plug (DE-9M) on the end intended for connection with the Model 5152. This cable will interface the digital audio signal sources with the 9-pin female “D-sub” (DE-9F) connector located on the back of the Model 5152. Refer to Figure 3 for detailed connection information.

It's expected that four independent pieces of coaxial cable will be used to bring the unbalanced digital audio signals into the DE-9M plug, so using miniature coaxial cable is highly recommended! The connector pin assignments were carefully selected to assist in making these “hot” and “shield” connections.

6	Input 1 (audio channels 1/2)
1	Shield 1
7	Input 2 (audio channels 3/4)
2	Shield 2
8	Input 3 (audio channels 5/6)
3	Shield 3
9	Input 4 (audio channels 7/8)
4	Shield 4
5	Not Used

Notes:

- 1) Connector type on Model 5152 is a 9-pin D-subminiature female (DE-9F). Installer must provide a 9-pin D-subminiature male (DE-9M). Connector uses 4-40 threaded inserts for locking with mating plug.
- 2) All inputs AES3 unbalanced digital audio; 75 ohm/1 Vpp (formerly AES3id).
- 3) Total of eight audio channels (four “stereo” pairs).

Figure 3. Digital Audio Input Connections

As a final step, the cable assembly's 9-pin plug should be mated with the connector on the Model 5152. The locking screws on the ends of the plug should be securely affixed to the "ears" of the connector. The two threaded fasteners associated with the "D-sub" use 4-40 threads.

DC Input and Data Bus

A 4-position header is used to connect DC power and a local RS-485 serial data bus to the Model 5152. Two pins on the mating connector are used to connect a source of nominal 12 volts DC. The acceptable range is 10 to 18 volts DC with a maximum current of 400 milliamperes at 12 volts DC. For remote control operation two pins on the mating connector will implement the data bus connection from a Studio Technologies' Model 5190 Remote Access Module.

The mating connector is compatible with the AMP MTA-100 series of IDC receptacles. For 22 AWG wire the closed-end-style receptacle is AMP 3-643813-4; the feed-through-style receptacle, used for busing connections, is AMP 3-644540-4. The body color for both receptacles is red, following the convention of the MTA-100 series for compatibility with 22 AWG wire. Refer to Appendix B of this guide for additional connector details.

-
1. – DC (Common)
 2. + DC (10-18 volts)
 3. + Data (RS-485)
 4. – Data (RS-485)
-

Figure 4. DC Input and Data Bus Connections

GPI and GPO

This section applies only to Model 5152 modules with serial numbers 00251 and later.

A 3-position header is used to connect with the Model 5152's GPI (general-purpose input) and GPO (general-purpose output) functions. Pin 1 is used by both the GPI and GPO, pin 2 is used by the GPI, and pin 3 by the GPO. The mating connector is compatible with the AMP MTA-100 series of IDC receptacles. For 22 AWG wire the closed-end-style receptacle is AMP 3-643813-3; the feed-through-style receptacle, used for busing connections, is AMP 3-644540-3. The body color for both receptacles is red, following the convention of the MTA-100 series for compatibility with 22 AWG wire. Refer to Appendix B of this guide for additional connector details.

Pins 1 and 2 should be connected to the switch or relay contact designated to control the GPI. Electrically the GPI (pin 2) is a logic input that is "pulled up" to 3.3 volts DC by way of a 5 k (5000) ohm resistor. It operates in a "logic low" manner requiring that the switch or contact closure carry a little less than 1 milliamperes (0.66 mA) to activate it. While the GPI circuitry is protected from over-current and static (ESD) discharge, care should be taken to prevent nasty signals from reaching it. The input is active only when held in the low state; it can't be configured to change state ("latch") in response to a momentary closure.

Pins 1 and 3 are used by the GPO. Pin 1 is common to the GPO, GPI, and the Model 5152's circuitry. Pin 3 is 3.3 volts DC, current limited by a series resistance of 150 ohms. The GPO is intended to directly power an LED indicator. Typical LEDs have a

1. Common
2. GPI (general-purpose input)
3. GPO (general-purpose output)

Figure 5. GPI and GPO Connections

drop of about 2 volts when active. This will result in a GPO output current of approximately 9 milliamperes. This LED current will be perfectly satisfactory in many applications but many contemporary LEDs can function effectively with less current. Adding additional series resistance can reduce the output current. For example, adding 100 ohms in series with the GPO will reduce the current through a typical LED to about 5 milliamperes. Note that shorting pin 3 to pin 1 when the GPO is active will result in a current flow of approximately 22 milliamperes. While this situation is not recommended it won't lead to any damage to the Model 5152's circuitry.

Mounting

The Model 5152 is intended for mounting in an installation-specific enclosure or rack panel. Refer to Appendix C at the end of this guide for details on the required mounting opening and screw locations. Please contact the factory to discuss mounting options.

Configuration

The manner in which a specific Model 5152 operates depends on how it has been configured. One configuration parameter, RS-485 Address, is set in hardware using four DIP switches. The other Model 5152 operating parameters can be set either by way of menu pages associated with a Model 5190 Remote Access Module or by way of a simple text file that is stored on a USB flash drive. (The file will automatically load when the USB flash drive is inserted into the Model 5152.) To assist in the configuration process an information file, STATUS.TXT, is automatically created by the Model 5152 and stored on the same USB flash drive.

Note that there are a number of unused DIP switches. One is located on the MCU board and five are located on the FPGA board. These switches are reserved for future use.

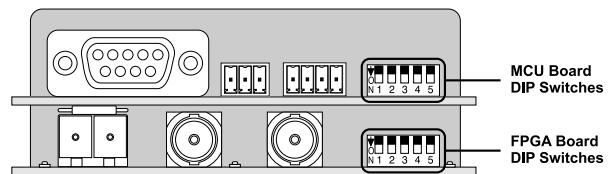

Figure 6. Rear view showing MCU and FPGA board configuration DIP switches

RS-485 Address

A data bus address must be configured for applications that implement remote control of Model 5152 functions. While up to 16 Model 5100-Series modules can “share” the RS-485 data bus, each module must have a unique address. Selecting the device's address involves setting four configuration switches on the MCU board. The switches are a “piano key” type with their up position being defined as off and their down position defined as on.

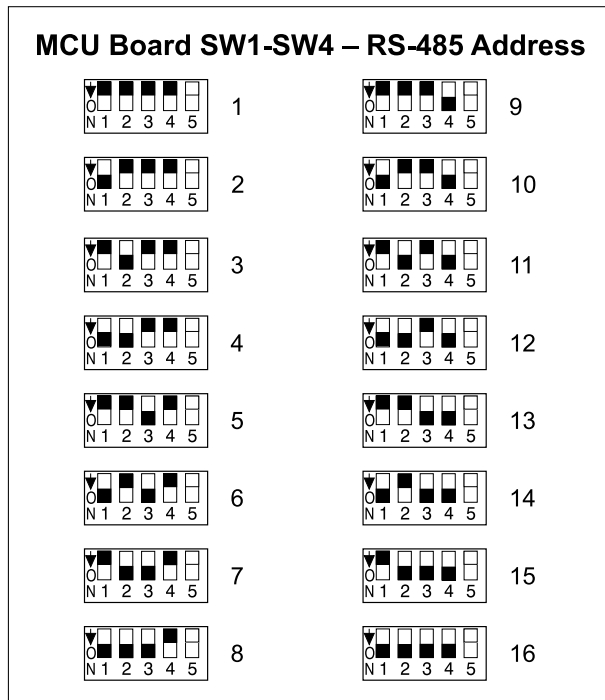

Figure 7. RS-485 Address Settings

Configuring Everything Else

Many other Model 5152 operating parameters can be configured using the Model 5190 Remote Access Module or by way of a text file. Details on how to use the Model 5190's menu pages are covered in other documentation. Understanding how to create and use a configuration text file will be covered in this guide.

An initial overview of the configuration choices is provided in the following paragraphs. Following these paragraphs are details on how to determine a module's current configuration and how to revise parameters as required.

SDI Input Select

The Model 5152 is capable of having its SDI input in the form of a coaxial signal (BNC connector) or an optical signal (SFP module). All versions of the Model 5152

support the coaxial (BNC) input. The optical input is an option and may or may not be present on the specific module you are configuring. Configuring this function can be performed using the Model 5190 Remote Access Module or by way of a text file stored on a USB flash drive.

SDI Output Image Format/Rate Mode

One setting is used to configure how the format and rate of the internal SDI generator is selected. (The internal SDI generator creates the short-duration solid-gray video image and plays back the stored "720" and "1080" images.) In the Auto mode the format and rate will automatically "follow" that of a connected SDI input. This allows the Model 5152 to automatically "learn" the specific format and rate used by a broadcast facility or live event. In the Locked mode the format and rate of the internal SDI generator will be "locked" so that it will not change. Configuring this mode can be performed using the Model 5190 Remote Access Module or by way of a text file stored on a USB flash drive.

Delay Before Stored Image

The Model 5152 can output a solid-gray video image prior to the stored image being generated. This is provided as an innocuous indication to downstream equipment that a loss of SDI has occurred. The solid-gray image can be selected to be present for a fixed duration of one to seven seconds. It can also be disabled allowing the stored image to be output as soon as a loss of an input SDI signal is detected.

Moving Image Overlay

A "moving" graphic image can be overlaid onto the stored "720" and "1080" images when either one is being output by the

Model 5152. The image is a red-colored box that slowly moves around the screen. This simple icon provides an indication to personnel located downstream of the Model 5152 that the SDI signal is active. This can be important to ensure that a distinction can be made between an active image and an image that's the result of the last valid frame being held and displayed by a piece of equipment even though its SDI input is no longer present.

When the function is off the stored images ("720" and "1080") will be displayed without the moving image being added. When the function is on the moving image will be added. Configuring this mode can be performed using the Model 5190 Remote Access Module or by way of a text file stored on a USB flash drive.

SDI Input as Timing Reference

In most applications it's desired that a signal connected to the selected SDI input will automatically be routed to the SDI output(s). But in special cases the Model 5152 may be used as a full-time video generator. In this latter case the ability to connect an external timing reference would be desirable. This would allow the SDI output(s) to be "locked" to a master or "house" timing signal. An operating mode selection allows an HD- or 3G-SDI signal to serve as a timing reference.

When the SDI Mode is set for Normal a signal connected to the Model 5152's selected SDI input will pass through to the SDI output(s). When SDI Mode is set for RefOnly the timing, rate, and format of the input SDI signal will impact the internally-generated video image output. The video information associated with the input signal will not be routed to the SDI output(s).

Configuring this mode can be performed using the Model 5190 Remote Access Module or by way of a text file stored on a USB flash drive.

Audio Embedding

One of the strengths of the Model 5152 is its ability to select which of the four digital audio inputs will be active and where their signals will be embedded into the SDI output "stream." Nine choices allow a wide range of embedding choices.

Four of the embedding choices are provided for applications that need to use just two of the Model 5152's four digital audio inputs. Digital audio inputs 1 and 2 (which are associated with four channels of audio) can be embedded into SDI groups 1, 2, 3, or 4. When one of these four choices is selected digital audio inputs 3 and 4 are not used and are effectively disabled.

Another four choices allow all four of the Model 5152's digital audio inputs (eight audio channels) to be embedded. The choices allow digital audio inputs 1 and 2 to be embedded into groups 1, 2, or 3 while digital audio inputs 3 and 4 are embedded into groups 2, 3, or 4.

A final choice allows the embedding process to be completely disabled. This is provided primarily for use during troubleshooting but may also find value when supporting special applications. When embedding by the Model 5152 is disabled any embedded audio groups that are present on the connected SDI input will pass unaltered through the module.

GPI – General-Purpose Input

Depending on the hardware version of the specific Model 5152 module there may be a GPI function available. The GPI (general-

purpose input) will allow connection of an external switch or contact closure. This will then control the on/off status of the Model 5152's embedder function. Configuring this function can be performed using the Model 5190 Remote Access Module or by way of a text file stored on a USB flash drive.

GPO – General-Purpose Output

Depending on the hardware version of a specific Model 5152 module there may be a GPO function available. The GPO (general-purpose output) can be configured to provide a signal corresponding to the status of one of several Model 5152 functions. The GPO can be configured to be either active high or active low when the module's selected SDI input is correctly "locked" to the incoming SDI signal. The GPO can also be configured to be active high or active low when the embedder function is active. Configuring this function can be performed using the Model 5190 Remote Access Module or by way of a text file stored on a USB flash drive.

Viewing Module Details

An associated Model 5190 Remote Access Module can be used to directly view firmware (embedded software), hardware, and configuration details about a Model 5152 module. In addition, the Model 5152 incorporates a unique standalone method of providing these details. This is accomplished by the module creating a simple text file which is stored on a USB flash drive. This file can then be easily viewed using a personal computer. Information provided in the file includes firmware version numbers, hardware serial number, and configuration settings. The information provided in the text file can provide assistance when configuring, using, and troubleshooting Model 5152 modules.

Each time a Model 5152 detects that a USB flash drive has been connected a text file will be created and stored. The file, named STATUS.TXT, will be stored in a folder named M5152 which is one level below the root of the USB flash drive. If the folder is not already present it will be created. If a STATUS.TXT file is already present a new one will automatically be written over it.

The Model 5152 does not have a method of accessing the current date or time, i.e., no real-time clock. This limitation requires that a fixed file creation date be used and 12/31/1979 was selected. However, the time stamp continues to advance in real time until a power cycle occurs.

The text contained in the STATUS.TXT file is organized into three sections. The following paragraphs provide a detailed explanation. Refer to Figure 8 for a display of a sample file.

STATUS.TXT File – [SYSTEM INFO]

The [SYSTEM INFO] section of the STATUS.TXT file provides general information about this specific Model 5152 module.

PRODUCT= identifies the module's product type. For the Model 5152 it will be listed as M5152. This information is provided as a confirmation for situations where multiple STATUS.TXT files are being examined.

SERNUM= identifies the factory-assigned serial number of this specific module. It will typically be in the form of a 5-digit base-10 number. If for some reason a serial number has not been factory assigned no number will display and the field will be blank (empty).

```
[SYSTEM INFO]
PRODUCT=M5152
SERNUM=00212
MCUVER=2.3
FPGAVER=2.2
ADDRESS=4

[CONFIGURATION]
SDIINPUT=BNC
FORMAT=AUTO
IMGDELAY=1
MOTION=ON
SDIMODE=NORMAL
EMBED=1N
GPI=DISABLED
GPO=DISABLED

[OPTIONS]
SDIINPUT=BNC,SFP
FORMAT=AUTO,LOCKED
IMGDELAY=0,1,2,3,4,5,6,7
MOTION=OFF,ON
SDIMODE=NORMAL,REFONLY
EMBED=NN,1N,2N,3N,4N,12,23,34,14
GPI=DISABLED,EMBEDOFF
GPO=DISABLED,SDIVALID,SDINOTVALID,
  EMBEDON,EMBEDOFF
```

Figure 8. Example of STATUS.TXT file

MCUVER= identifies the version of the microcontroller (MCU) firmware (embedded software) that's loaded into and operating in this specific module's MCU board. The microcontroller is the overall "boss" of the Model 5152, doing pretty much everything but the SDI-related tasks.

FPGAVER= identifies the version of the logic chip (FPGA) firmware (embedded software) that's loaded into and operating in this specific module's FPGA board. The FPGA creates the video images, processes the SDI signals, and handles the audio embedding.

ADDRESS= identifies the RS-485 data bus address of this specific module. The range is 1 through 16. This address is configured using four DIP switches located on the MCU board.

STATUS.TXT File – [CONFIGURATION]

The [CONFIGURATION] section of the STATUS.TXT file provides details on how the module is actually functioning at the time the file was created.

SDIINPUT= identifies which physical SDI input on the module has been selected.

BNC indicates that the Coaxial (BNC) SDI Input has been selected. **SFP** indicates that the optical SDI input has been selected.

FORMAT= identifies which SDI Output Image Format/Rate Mode has been selected. **AUTO** indicates that the Auto Select (Follows Input) mode has been selected. **LOCKED** indicates that the Locked (Does Not Follow Input) setting has been selected.

IMGDELAY= identifies the interval selected for the delay before the stored image is output. The range is 0 to 7 seconds. A setting of 0 indicates that there will be no delay. During the delay period the Model 5152 will output a video image with a solid-gray color.

MOTION= identifies the status of the Moving Image Overlay function. **OFF** indicates that the Moving Image Overlay function is not active. **ON** indicates that the Moving Image Overlay function is active.

SDIMODE= identifies which SDI Mode has been selected. **NORMAL** indicates that a valid SDI signal connected to the selected SDI input will pass through to the module's SDI output(s). **REFONLY** indicates that the selected SDI input will serve only as a timing reference signal. The internally-generated image will always be sent to the SDI output(s).

EMBED= identifies how audio signals connected to the Model 5152 are being embedded into the SDI output signal. The first digit represents what happens to the audio associated with digital audio inputs 1 and 2. The second digit represents what happens to the audio associated with digital audio inputs 3 and 4. Each digit can be either **N**, **1**, **2**, **3**, or **4**, with **N** representing no embedding and the numerical digits representing an SDI group number.

GPI= identifies how the GPI (general-purpose input) function has been configured. **NA** indicates that the hardware version of this specific Model 5152 module does not support the GPI function (applies to modules with serial numbers 00250 or less). **DISABLED** indicates that the function is present in hardware but is not active. **EMBEDOFF** indicates that the GPI will control the on/off status of the Model 5152's embedder function.

GPO= identifies how the GPO (general-purpose output) function has been configured. **NA** indicates that the hardware version of this specific Model 5152 module does not support the GPO function (applies to modules with serial numbers 00250 or less). **DISABLED** indicates that the function is present in hardware but is not active. **SDIVALID** indicates that the GPO will be high when a valid SDI signal is connected to the selected SDI input (coaxial (BNC) or optical). **SDINOTVALID** indicates that the GPO will be high when a valid SDI signal is not connected to the selected SDI input (coaxial (BNC) or optical); the GPO will be low when a valid SDI signal is connected. **EMBEDON** indicates that the GPO will be high when the embedder function is enabled. **EMBEDOFF** indicates that the GPO will be high when the embedder function is

not enabled; the GPO will be low when the embedder function is enabled.

STATUS.TXT File – [OPTIONS]

The [OPTIONS] section of the STATUS.TXT file is provided as a guide when creating a configuration file (CONFIG.TXT) which will set the module's configuration. This information is provided in the STATUS.TXT file only as a reference and doesn't play an active part in module configuration or operation.

SDIINPUT= selects which physical SDI input on the module will be active. **BNC** selects the coaxial (BNC) SDI input to be active. **SFP** selects the optical SDI input to be active.

FORMAT= selects the SDI Output Image Format/Rate Mode. **AUTO** selects the Auto Select (Follows Input) mode. **LOCKED** selects the Locked (Does Not Follow Input) mode.

IMGDELAY= selects the interval for the delay before the stored image is output. The range is 0 to 7 seconds. A setting of 0 selects no delay. During the delay period the Model 5152 will output a video image with a solid-gray color.

MOTION= selects the Moving Image Overlay function. **OFF** disables the Moving Image Overlay function. **ON** enables the Moving Image Overlay function.

SDIMODE= selects the SDI Mode function. **NORMAL** selects that a valid SDI signal connected to the selected SDI input will pass through to the module's SDI output(s). **REFONLY** selects that the selected SDI input will serve only as a timing reference signal. In this latter mode, the internally-generated image will always be sent to the SDI output(s).

EMBED= selects how audio signals connected to the Model 5152's digital audio inputs are to be embedded into the SDI output signal. The first digit represents what is to happen to the audio associated with digital audio inputs 1 and 2. The second digit represents what is to happen to the audio associated with digital audio inputs 3 and 4. Each digit can be either **N**, **1**, **2**, **3**, or **4**. The digit **N** indicates that the digital audio inputs are not to be embedded. The numbers **1**, **2**, **3**, and **4** represent the SDI group that the digital audio inputs are to be embedded into. The [CONFIGURATION] section of Figure 8 shows **EMBED=12** which indicates that digital audio inputs 1 and 2 are being embedded into SDI group 1 and digital audio inputs 3 and 4 are being embedded into SDI group 2.

GPI= selects the GPI (general-purpose input) function. **DISABLED** selects that the function is not active. **EMBEDOFF** selects that the GPI will control the on/off status of the Model 5152's embedder function. Note that if the hardware version of this specific Model 5152 does not support the GPI function (modules with serial numbers 00250 or less) this text line will not appear.

GPO= selects operation of the GPO (general-purpose output) function. Five choices are available. **DISABLED** selects the GPO function to be inactive. It will remain logic low and not change state. **SDIVALID** selects that the GPO will be high when a valid SDI signal is connected to the selected SDI input (coaxial (BNC) or optical). **SDINOTVALID** selects that the GPO will be high when a valid SDI signal is not connected to the selected SDI input (coaxial (BNC) or optical); the GPO will be low when a valid SDI signal is connected. **EMBEDON** selects that the GPO will be

high when the embedder function is active. **EMBEDOFF** selects that the GPO will be high when the embedder function is not active; the GPO will be low when the embedder is active. Note that if the hardware version of this specific Model 5152 does not support the GPO function (modules with serial numbers 00250 or less) this text line will not appear.

Configuration Text File

A text file can be created to specify how a Model 5152 should be configured. Saved on a USB flash drive, the file must have a name of CONFIG.TXT and be stored in a folder directly under the root with a name of M5152. When the USB flash drive is plugged into a Model 5152 the file will automatically be read and the configuration stored. Immediately after the file is read the STATUS.TXT file will be written to the M5152 folder. The contents of this file will reflect the configuration that's present after the contents of the CONFIG.TXT have been read. This will provide immediate feedback that the desired configuration has been implemented.

The following paragraphs detail the configuration choices. Refer to the Figure 9 for a sample file. This information is also shown in the [OPTIONS] section of the STATUS.TXT file, described previously in this guide.

The text lines that follow the [CONFIGURATION] heading should remain in the same order as shown in the example. (But technically they are not required to do so.) All configuration items are not required to be present but for clarity it's recommended that they are. The text is case sensitive and must follow the example.

```
[CONFIGURATION]
SDIINPUT=BNC
FORMAT=AUTO
IMGDELAY=1
MOTION=ON
SDIMODE=NORMAL
EMBED=1N
GPI=DISABLED
GPO=SDIVALID
```

Figure 9. Example of CONFIG.TXT file

SDIINPUT= selects which physical SDI input on the module will be active. There are two choices. **BNC** selects the coaxial (BNC) SDI input to be active. **SFP** selects the optical SDI input to be active.

FORMAT= selects the SDI Output Image Format/Rate Mode. There are two choices. **AUTO** selects the Auto Select (Follows Input) mode. **LOCKED** selects the Locked (Does Not Follow Input) mode.

IMGDELAY= selects the interval for the delay before the stored image is output. The range is 0 to 7 seconds. A setting of 0 selects no delay. During the delay period the Model 5152 will output a video image with a solid-gray color.

MOTION= selects the status of the Moving Image Overlay function. There are two choices. **OFF** disables the Moving Image Overlay function. **ON** enables the Moving Image Overlay function.

SDIMODE= selects the status of the SDI Mode function. There are two choices. **NORMAL** selects that a valid SDI signal connected to the selected SDI input will pass through to the module's SDI output(s). **REFONLY** selects that the SDI input will serve only as a timing reference signal. The internally-generated image will always be sent to the SDI output(s).

EMBED= configures how audio signals connected to the Model 5152's digital audio inputs are to be embedded into the SDI output signal. The first digit represents what is to happen to the audio associated with digital audio inputs 1 and 2. The second digit represents what is to happen to the audio associated with digital audio inputs 3 and 4. The digit **N** indicates that the digital audio inputs are not to be embedded. The numbers **1, 2, 3,** and **4** represent the SDI group that the digital audio inputs are to be embedded into. Figure 9 shows **EMBED=34** which indicates that digital audio inputs 1 and 2 are to be embedded into SDI group 3 and digital audio inputs 3 and 4 are to be embedded into SDI group 4. Another example would be **EMBED=2N** which would specify that digital audio inputs 1 and 2 are to be embedded into SDI group 2 while digital audio inputs 3 and 4 are not to be embedded (inactive).

A special configuration selection is **EMBED=NN**. This configures the Model 5152 to not embed any audio signals. In this situation any embedded audio associated with the connected SDI input will pass through the module. While this configuration will typically not be used it can prove to be useful in certain situations. For example, it can be used during troubleshooting, disabling the Model 5152's embedding function and allowing an SDI input to pass through the module completely unchanged. Test signals can be confirmed as passing through the module correctly and terminating on a downstream piece of equipment. Turning off embedding can also be useful when, in a special application, all the audio groups associated with an SDI input need to remain embedded and pass through to the Model 5152's SDI output.

GPI= selects the status of the GPI (general-purpose input) function. **DISABLED** selects that the function is not active. **EMBEDOFF** selects that the GPI can be used to control the on/off status of the Model 5152's embedder function. The function is active low. When the GPI is not pulled low (switch or contact closure open (not shorted)) the embedder function is active. When the GPI is low (switch or contact closure closed (shorted)) the embedder function is disabled. (Of course, if embedding has been disabled in the configuration (**EMBED=NN**), the GPI function would not impact embedder operation.) Note that if the hardware version of this specific Model 5152 does not support the GPI function this text line can be part of the file but will not be recognized.

GPO= selects the status of the GPO (general-purpose output) function. Five choices are available. **DISABLED** selects the GPO function to be inactive. It will remain logic low and not change state. **SDIVALID** selects that the GPO will be high when a valid SDI signal is connected to the selected SDI input (coaxial (BNC) or optical). **SDINOTVALID** selects that the GPO will be high when a valid SDI signal is not connected to the selected SDI input (coaxial (BNC) or optical); the GPO will be low when a valid SDI signal is connected. **EMBEDON** selects that the GPO will be high when the embedder function is active. **EMBEDOFF** selects that the GPO will be high when the embedder function is not active; the GPO will be low when the embedder is active. Note that if the hardware version of this specific Model 5152 does not support the GPO function this text line can be part of the file but will not be recognized.

Operation

Power Up

Upon 12 volt DC power being applied to the Model 5152 the twelve front-panel LEDs will perform a "walk-through" test, with each LED lighting briefly in sequence. Then the LEDs will light in patterns that represent the version numbers of the firmware (embedded software) files that are loaded into the module. Upon completion, the Power LED will light continuously. For normal operation to commence, prior to powering up the module ensure that a USB flash drive is not plugged into the USB port on the front panel.

LED Indicators

A brief discussion of the Model 5152's status LEDs will be covered in this section.

Front-Panel LEDs

As previously discussed, upon power up the twelve front-panel LEDs will light in a short sequence as an initialization test. Afterwards they are used to display the version number of the installed MCU and FPGA firmware. Refer to the Technical Notes section of this guide for details. Following the power-up sequence, the Power LED will light and remain lit.

The USB Activity LED will not light during normal Model 5152 operation. It will be lit continuously or in a pattern when a USB flash drive is plugged into the USB port on the front panel and file transfer activity is taking place. Details on how the LED functions when the USB port is active are covered in the Technical Notes section of this guide.

The SDI Input LED lights whenever a valid SDI signal is connected to the coaxial (BNC) or optical SDI input. (A configuration choice selects whether the coaxial (BNC) SDI input or optical SDI input is active.)

The Data LED will light whenever data activity is taking place over the local RS-485 signal bus that is used to link the Model 5152 to a Studio Technologies' Model 5190 Remote Access Module. The LED will flash on and off each time data associated with this specific Model 5152 is present. Not all applications will include a connection to the data bus so it's certainly possible that the Data LED may never flash except during module power up.

The eight LEDs associated with the digital audio inputs will light whenever signal is present on their associated audio channels and embedding of these signals into the SDI signal is taking place. Details regarding the functioning of these LEDs are included later on in this section.

FPGA Board LEDs

Three LEDs are located on the back edge of the FPGA printed circuit board and serve as factory- and field-diagnostic aids. Upon Model 5152 power up each LED will light for several brief durations with no specific meaning associated with them. Then the FPGA Status LED, located adjacent to the DIP switches, will light and remain lit. This indicates that the FPGA and MCU boards are correctly communicating.

The LED located adjacent to the coaxial SDI input's BNC connector will light whenever that input has been configured to be active and a valid SDI signal is connected. It will not light if a valid SDI signal is connected but the SDI input configuration is not set to activate the coaxial (BNC) input.

The LED located adjacent to the "cage" that holds the SFP module will light if the optical SDI input has been selected and a valid SDI optical signal is connected. It will not light if a valid optical signal is connected but the SDI input configuration is not set to activate the optical input.

A fourth LED is located near the front of the FPGA board. Called the FPGA Done LED, it lights whenever the logic device (FPGA) has loaded its firmware and is operating normally. This LED is provided only for factory troubleshooting use.

Initial SDI Output

After the power-up sequence has been completed the module's SDI output will become active. (This will be both the coaxial (BNC) output and, if present, the optical SDI output.) If a valid signal is connected to the selected SDI input it will be routed to the SDI output. If a signal is not connected to the selected SDI input the internal SDI generator will supply a signal to the SDI output. In the latter case, what occurs after the Model 5152's power-up sequence has taken place (taking about seven seconds) depends on the module's configuration. A solid-gray image may be output for up to seven seconds followed by the stored "720" or "1080" image. Or, if the solid-gray image has been disabled the stored image will immediately be present.

SDI Input and SDI Output

Depending on the exact Model 5152 version that has been installed and how it was configured an SDI signal can be connected to the coaxial (BNC) input or the optical input. When a signal that's compatible with the Model 5152 has been connected the front-panel SDI Input LED will light. This

indicates that the signal is being routed to the SDI output and the internal SDI generator is not active. SDI signals that comply with most HD (1.485 Gb/s nominal) and 3G (2.97 Gb/s nominal) standards are compatible. Refer to the Specifications section of this guide for a list of the supported standards.

The Model 5152 always provides an active SDI signal on the coaxial (BNC) output. Some Model 5152 versions also provide an optical output. This is accomplished at the factory by installing one of a variety of available SFP optical modules in the back-panel SFP “cage.” If an optical output is present it will always be active and provide an identical copy to the signal present on the coaxial (BNC) output.

If a valid SDI signal is not connected to the selected SDI input the stored image will be present on the coaxial (BNC) output and, if present, optical output. Depending on the stored format and rate values, the output will be either a 1280 x 720 pixel (“720”) or 1920 x 1080 pixel (“1080”) fixed image.

Stored Images

When a valid signal is not connected to the selected SDI input, the module generates one of two fixed images. The two images, one “720” and one “1080,” are stored in nonvolatile memory within the Model 5152. From the factory two images are pre-loaded. The two are quite different from one another with each having a unique photo background and overlaid text. The overlaid text provides support details on how alternate custom images can be created.

It’s expected that these pre-loaded images will be replaced with application-specific images. They can be easily created and

what they consist of is limited only by one’s imagination. Refer to the Technical Notes section of this guide for details.

Transitions between External and Internal SDI Signals

This paragraph applies when the Model 5152 has been configured for normal SDI input mode. Whenever a valid SDI signal is connected to the selected Model 5152 input it will immediately be routed to the coaxial (BNC) and, if present, optical SDI outputs. The situation is a little different when a valid signal that’s been connected to the selected SDI input is subsequently removed. When the Model 5152 detects that an SDI input signal is no longer present the SDI output may switch to an image with a solid-gray color. Depending on the module’s configuration this color may remain active for up to seven seconds. This solid-gray image provides a benign warning to users that the normal SDI source is no longer present.

During this time period it’s expected that any on-air use of the Model 5152’s output can be terminated without alerting viewers that anything is amiss. This solid-gray image can also be helpful as a marker when editing recorded video. After the configured interval has elapsed the internal generator will output either the “720” or “1080” stored image.

It’s also possible that the Model 5152 has been configured to not output the solid-gray video signal. In this case, when the module detects that an SDI signal is no longer present on the SDI input, the SDI output will directly switch to the stored image.

It's important to note that the Model 5152 does not perform a smooth transition when switching between an external SDI source and the internally-generated video signals. The same holds true when the internal color or image generator is active and then a valid source is connected to the selected SDI input. The SDI output does not stay "locked" during the transition as the circuitry in the Model 5152 was not designed to that level of sophistication. This shouldn't cause an operational issue as the Model 5152 was not designed to be "on air" during those transitions; the changeover process is not seamless by design. One can assume that up to two seconds of interruption will occur during transitions but typically it will be considerably shorter.

Full-Time Video Generation

A configuration selection allows the Model 5152 to act as a full-time video generator. In this case the selected SDI input will only be used as an external timing reference. The front-panel SDI Input LED will light whenever a valid signal is connected to the selected SDI input. But the SDI input source will only serve as a timing reference. Its video and related data (e.g., embedded audio) will not pass through to the SDI output(s). The stored video image will always be present on the SDI output(s).

Output Format and Rate

When a valid signal is connected to the selected SDI input it will be routed to the SDI output at the identical format and rate of the source. When the SDI input is no longer present the internally-generated signal will become active and be routed to the SDI output. The format and rate of the internally-generated SDI signal will depend on parameters that are stored within the

Model 5152. Whether these parameters can change depends on the configuration of the module's SDI output image format/rate mode. Typically, the mode will be set for Auto Select which allows the Model 5152 to revise its parameters by following the format and rate of the connected SDI signal. This ensures that the Model 5152 can generate an SDI signal that matches the requirements of a facility or event. For the module to "learn" a new format and rate simply requires the momentary connection of an SDI signal that has the desired format and rate. As long as the signal is present on the selected SDI input for a minimum of five seconds the Model 5152 will store the "new" format and rate parameters in nonvolatile memory. The module will then use those parameters whenever the internal generator is active. The only caveat for the module to "learn" a new format/rate combination is that it must be a compatible combination. Refer to the Specifications section of this guide for a complete list.

There are some applications that will benefit from the internally-generated SDI output signal always having a specific format and rate. In this case the SDI output image format/rate mode can be set for Locked. No matter what the format and rate of a connected SDI signal, the stored parameters will not change. Changing the stored parameters would require the format/rate mode to be changed to Auto Select, an SDI signal with the desired format and rate be connected for a minimum of five seconds, and then the format/rate mode changed back to Locked.

Moving Image Overlay

The Model 5152 has the ability to overlay a moving image on top of the stored "720"

and “1080” images. A configuration setting selects whether the moving image overlay will be active. The moving image, a box that’s red in color, slowly moves around and on top of whatever stored image is present on the SDI output. The color, size, and rate of motion of the “box” are fixed in the FPGA’s firmware (embedded software) and can’t be altered.

The moving image is provided specifically so that users who are “downstream” from the Model 5152’s SDI output are assured that the “720” or “1080” image they are viewing is active. And, just to clarify, if a signal is present on the Model 5152’s selected SDI input it will be passed on to the coaxial (BNC) and, if present, optical SDI outputs. The moving image will never overlay an input signal—it can only overlay on top of the stored image.

Audio Embedding

The Model 5152 can embed up to eight audio channels into the SDI output signal. These audio channels originate as four digital audio pairs that are connected to the digital audio inputs. Exactly how the module embeds the audio depends on how the module has been configured. There are nine configuration choices. Note that one of the choices is to not embed at all, something that’s included primarily as a test function. Refer to the Configuration section for details.

There are eight signal present status LEDs associated with the eight audio channels that originate with the four digital audio inputs. (Two audio channels are associated with each of the four AES3-compatible digital audio inputs.) A signal present LED will light when its associated audio channel has met two conditions.

The first is that this channel (as part of a channel pair) has been configured to be embedded. The second is that signal level on that channel must exceed -40 dBFS. This level is 20 dB below the nominal audio level of -20 dBFS for SMPTE applications. For EBU applications it will light 22 dB below the nominal -18 dBFS level.

Audio will be embedded into the SDI output signal whether or not an SDI input (coaxial (BNC) or optical) signal is present. If no signal is present on the selected SDI input the custom image will be active and audio will be embedded into it.

If a valid signal is present on the selected SDI input it will pass through to the coaxial (BNC) output and, if present, the optical SDI output. The Model 5152 will embed audio into the SDI input signal following the selected configuration choice. It will replace any audio signal already present on the selected group or groups. To clarify, the SDI signal connected to the input will pass through to the output but audio already present on the group or groups selected to be embedded by the Model 5152 will be replaced.

A subtle but potentially important topic must be covered. With the Model 5152’s embedding flexibility it’s possible that equipment connected to the SDI output(s) could exhibit less-than-desirable performance. Embedded audio data will only be present on the Model 5152’s SDI output(s) according to the configuration setting. There is no requirement that a specific group, such as group 1, be active. In the case where no valid SDI source is connected to the selected SDI input, the SDI output signal will consist of the custom “720” or “1080” image along with the embedded audio. As such, ancillary data

created by the embedding process will only be present for the specific configured audio group or groups. For example, if the Model 5152 has been configured for digital audio inputs 1 and 2 to be embedded into SDI group 3, then there will be no ancillary data packets present in the SDI output for groups 1, 2, and 4. Only if a connected SDI signal has embedded audio on those groups (1, 2, and 4) will they be present in the Model 5152's SDI output(s). This can be significant as it's been discovered that some equipment that receives SDI signals expects that embedded audio will be present, at a minimum, on group 1. So embedding audio, as an example, that is only present on group 3 could cause an issue.

GPI and GPO

Model 5152 modules with serial numbers of 00251 and later include a GPI (general-purpose input) and a GPO (general-purpose output) function. Depending on the application, connections may have been made to the GPI and/or the GPO.

GPI

The GPI function allows the Model 5152's audio embedder function to be disabled (turned off) in response to an external command. This requires that the GPI has been connected to an external switch or contact closure and the function configured to be enabled. When the GPI is open (not shorted; logic "high") the specific action of the embedder function would be controlled by the embedding configuration parameter. When the GPI is shorted to common (pulled "low") the embedding configuration is temporarily ignored and the embedder function is disabled. Any embedded audio present on the SDI input source will pass through to the Model 5152's SDI output(s).

GPO

The GPO may be connected to an LED indicator or computer-based monitoring system. A configuration choice allows the GPO to be configured from among five choices. One is disabled and the GPO will remain logic low constantly. It can also be configured to be active "high" or active "low" in response to a SDI signal connected and "locked" to the selected SDI input. If configured for active high an associated LED, for example, would light whenever a valid SDI source is connected to, and "locked," with the selected SDI input. If configured for active low the LED would light whenever a valid SDI is not connected to the selected SDI input. The GPO can also be configured to be active high or active low in response to the on/off status of the embedder function.

Technical Notes

Bitmap Image File Requirements

The Model 5152 allows two bitmap (.bmp) images to be stored and output when an SDI input signal is not present. One image has a pixel size of 1280 x 720 while the other has a pixel size of 1920 x 1080. To be stored with the Model 5152 the files must be FAT32-compatible and have names of **img720.bmp** and **img1080.bmp**, respectively.

The reason two files are required is simple: the Model 5152 does not have the ability to digitally "scale" a 1920 x 1080 image down to 1280 x 720. But it does have the ability to store two unique files. Most users will create a single image using a personal-computer graphics program and then save

it in the two required formats. So when the Model 5152 generates either of the two images (“720” or “1080”), a user will see what appears to be an identical image. But there is no reason why the two images (“720” and “1080”) have to be based on the same original graphics. Studio Technologies chose to create two different “720” and “1080” bitmap files that are pre-loaded in the Model 5152 at the time of manufacture. They feature two unique background images with text highlighting the main requirements for updating them.

While the two bitmap files (**img720.bmp** and **img1080.bmp**) are “standard” in the sense that they are FAT32-compatible and have the extension .bmp, they must adhere to one important requirement that not all personal-computer graphics programs support. Their DIB (bitmap information header) must be a BITMAPINFOHEADER type. The Microsoft Paint and Adobe Photoshop applications will create .bmp files that meet this requirement. But some other programs may produce non-compatible files. For example, the open-source GIMP graphics program is very good but appears to save .bmp files only as a BITMAPV4HEADER type. These are not compatible with the Model 5152. The possibility that various .bmp files will have different header types doesn’t seem to be an issue for displaying them successfully with most personal-computer programs. This is most likely due to the PC’s large code space allowing essentially all the possible header types to be supported. But the Model 5152, due to its target application, has limitations in the file support area. (For additional background information, please refer to the Wikipedia online entry that discusses the structure of .bmp files.)

A compatible 1280 x 720 (“720”) .bmp file created using Microsoft Paint or Adobe Photoshop will have a size of approximately 2.63 MB; a 1920 x 1080 (“1080”) .bmp file will have a size of approximately 5.63 MB. The actual size of the files when created in Microsoft Paint should be 2,764,854 bytes and 6,220,854 bytes, respectively. When created in Adobe Photoshop, the file sizes should be 2,764,856 bytes and 6,220,856 bytes, respectively. (Why are they each two bytes in size different? Who knows! But both use the appropriate BITMAPINFOHEADER DIB type.)

Bitmap Image Update Procedure

It’s expected that the Model 5152’s bitmap (.bmp) files associated with the custom “720” and “1080” images will always be updated to best serve specific applications. This will typically take place soon after a Model 5152 has been installed. (While the pre-loaded images are nice, they aren’t really appropriate for actual active applications.) There’s no problem changing the files whenever the application warrants alternate images. The module has the ability to automatically load revised files by way of its USB interface. The Model 5152 implements a USB host function that directly supports connection of a USB flash drive.

Updating the Model 5152’s “720” and “1080” images is quite simple but requires some care. The process begins by preparing a USB flash drive. The flash drive doesn’t have to be empty (blank) but must be in the personal-computer-standard FAT32 format. Save the new image (.bmp) files in the root directory. Their names must be **img720.bmp** and **img1080.bmp**.

Typically both .bmp files will be updated at the same time. But there's no requirement to do so. Individual files can be updated whenever desired. Simply copy the desired file or files to the root directly on the USB flash drive. Be certain that there are no Model 5152 firmware files (**m5152.s19** and **m5152.bit**) present on the USB flash drive during this process.

As previously reviewed in this guide, the 1280 x 720 image must have a file name of **img720.bmp**; the 1920 x 1080 image must have a file name of **img1080.bmp**. Also ensure that both have the DIB header type BITMAPINFOHEADER so that they can be recognized correctly by the Model 5152.

To install the new image files:

1. Power down the Model 5152 module.
2. Insert the prepared USB flash drive into the module's USB port.
3. Apply power to the module.
4. The module will go through its power-up LED sequence and normal operation will begin. At about the same time that normal operation starts the new .bmp files will begin to load, one after the other. The USB Activity LED on the module's front panel will flash while the loading process is taking place. Loading both .bmp files will take approximately 6.5 minutes. (Loading only the **img720.bmp** file takes approximately 2 minutes; loading only the **img1080.bmp** file takes approximately 4.5 minutes.) Once the loading process has been completed the USB Activity LED will change from flashing to being lit continuously.

Note: If the module is currently outputting one of the stored images and a new image of the same type ("720" or "1080") has just completed loading, the output will automatically change to the new image. (It's possible that a few seconds of a solid color could be output during the transition from the old image to the new image.)

5. Power down the module.
6. Remove the USB flash drive from the module's USB port.
7. Power up the Model 5152 module. It will go through its normal power-up LED sequence and begin operation. It will use the updated images whenever the internal SDI generator is active.

It's possible that during the update process any LEDs located on the USB flash drive may light steadily or flash with varying patterns. These actions are not significant to the Model 5152's update procedure. (The status LEDs on various USB flash drives seem to behave in different ways so there are no universal patterns that can be identified.)

Firmware Update Procedure

It's possible that updated versions of the firmware (embedded software) that runs the Model 5152 will be released to add features or correct issues. The module has the ability to automatically load revised files by way of its USB interface. The Model 5152 implements a USB host function that directly supports connection of a USB flash drive. The Model 5152 uses two firmware files to perform its functions. One file is used by the microcontroller integrated circuit (MCU) and has a file name of **m5152.s19**. The microcontroller is the overall "boss" of the Model 5152, doing

pretty much everything but the SDI-related tasks. The other firmware file is used by the logic chip (FPGA) and has a name of **m5152.bit**. This firmware, running in the FPGA, creates the video images, processes the SDI signals, and handles audio embedding. The factory will provide updates of these firmware files if it's warranted for your specific Model 5152 module.

To update the Model 5152's firmware is quite simple but requires careful execution. The process begins by preparing a USB flash drive. The flash drive doesn't have to be empty (blank) but must be in the personal-computer-standard FAT32 format. Save the new firmware files in the root directory. Their names must be **m5152.s19** and **m5152.bit**. Be certain that any custom image files (**img720.bmp** and **img1080.bmp**) are not present on the USB flash drive during this process.

Studio Technologies will supply the MCU and FPGA files inside individual .zip archive files. While the firmware file inside of each zip file will adhere to the naming convention required by the Model 5152, the name of the zip file itself will include the version number. For example, a file named **m5152v1r2MCU.zip** would indicate that version 1.2 of the MCU firmware (**m5152.s19**) is contained within this zip file; a file named **m5152v1r1FPGA.zip** would indicate that version 1.1 of the FPGA (**m5152.bit**) is contained within this zip file. The version numbers of the files that are copied to the USB flash drive should be noted for later reference. Once the new files are loaded into a Model 5152 the module's front-panel LEDs should be used to confirm that the correct firmware versions have been successfully installed.

Note: The firmware update procedure itself will not erase or overwrite bitmap image files that are already saved in the Model 5152. However, this requires that the custom image files (**img720.bmp** and **img1080.bmp**) are not present on the USB flash drive.

To install the firmware files:

1. Power down the Model 5152 module you intend to upgrade.
2. Ensure nothing is inserted into the USB port on the module. Power up the module and "read" the version numbers of the currently-installed MCU (**m5152.s19**) and FPGA (**m5152.bit**) files. Write these numbers down for reference. The next section of this guide details how to "read" the installed firmware version levels.
3. Power down the Model 5152 module.
4. Insert the prepared USB flash drive into the module's USB port.
5. Apply power to the Model 5152 module.
6. The module will run a "boot loader" program that will immediately load the new MCU (**m5152.s19**) file. This takes approximately eight seconds. Once the file is loaded the module will perform a normal power-up sequence with the microcontroller using its newly-loaded MCU firmware.
7. After the power-up sequence has been completed the module will begin operation. It will process video and audio as well as checking for an FPGA (**m5152.bit**) file on the USB flash drive. If it doesn't find this file normal operation will continue. If it locates this file it will begin to load it from the USB flash drive. In that case, some Model 5152

functions will halt, including reading changes to the configuration switches. As an indication that the file transfer is under way, the USB Activity LED will flash on and off.

8. The process of loading the FPGA (**m5152.bit**) file will take approximately 90 seconds to complete. When the file loading process is complete you will see the module's front-panel USB Activity LED change from flashing to being continuously lit. At that time the Model 5152's logic chip (FPGA) will reboot and run under the newly-loaded firmware.
9. Power down the module.
10. Remove the USB flash drive from the module's USB port.
11. Power up the Model 5152 module and it will begin operation using the updated MCU and FPGA firmware. The version numbers of the installed MCU and FPGA firmware should be "read" by way of the front-panel LEDs. Compare and confirm that these numbers match those from the zip file names that were provided by the factory.

Note: It's possible that during the update process any LEDs located on the USB flash drive may light steadily or flash with varying patterns. These actions are not significant to the Model 5152's firmware update process. (The status LEDs on various USB flash drives seem to behave in different ways so there are no universal patterns that can be identified.)

Identifying the Installed Firmware Versions

As previously discussed in the Configuration section of this guide, a file is automatically written to a USB flash drive whenever it is plugged into the Model 5152. This file, named STATUS.TXT, provides details of the Model 5152's firmware (embedded software), hardware, and configuration parameters. These parameters include the version numbers of the MCU and FPGA firmware that are stored in the module. This information is also available when using a Model 5190 Remote Access Module with the Model 5152. A third method is also available to determine the two firmware version numbers. The Model 5152's status LEDs are used during the power-up sequence to display the numbers in a cryptic but effective manner. While the display method is a bit unique, once a user gets accustomed to what's actually happening during power up it should be fairly straightforward to "read" the version numbers.

To identify the installed firmware versions:

1. Power up the Model 5152. The LEDs will perform a "walk-through" test, with each LED briefly lighting in a sequence.
2. Next the Power LED will light and remain lit.
3. Very shortly after the Power LED lights the USB Activity LED will light to indicate that the MCU firmware version is being displayed by the eight Digital Audio Inputs Signal Present LEDs. The top row of four LEDs will display the major version number with a range of 1-4. The bottom row of four LEDs will display the minor version number with a range of 0 (no LED lit) to 4. Refer to Figure 10 for details.

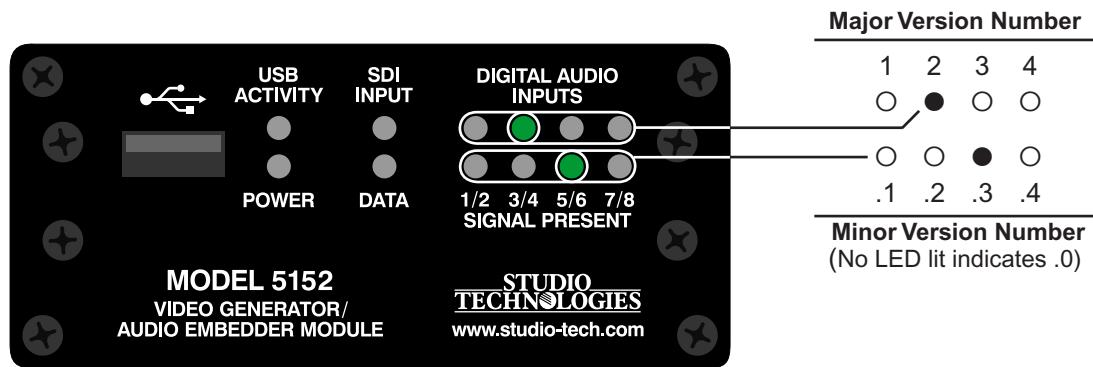

Figure 10. Detail of front panel showing the LEDs that display the MCU and FPGA firmware versions. In this example, the version shown is 2.3.

4. After a few seconds the USB Activity LED will go out and the FPGA firmware version will be displayed by the eight Digital Audio Inputs Signal Present LEDs. The top row of four LEDs will display the major version number with a range of 1-4. The bottom row of four LEDs will display the minor version number with a range of 0 (no LED lit) to 4. Refer to Figure 10 for details.
5. After a final short pause the LEDs will begin performing in their normal operating manner. The Power LED will remain lit. The USB Activity LED will only be active when a USB flash drive is inserted and file transfer activity is taking place. The SDI Input LED will light whenever a valid SDI signal is connected to either the coaxial (BNC) input or the optical input, depending on the module's capability and configuration setting. The Data LED will light whenever local data is received via the RS-485 data bus from a Studio Technologies' Model 5190 Remote Access Module. If digital audio input signals have been configured to be embedded their associated Digital Audio Inputs Signal Present LEDs will light whenever signal levels are -40 dBFS or greater.

Once a user gets accustomed to what's actually happening during power up it should be fairly straightforward to "read" the version numbers.

SFP Module Flexibility

The Model 5152 was designed to allow an MSA-compliant SFP optical module to be installed at the factory. Optical modules are available with a range of input and output capabilities to meet the needs of various applications. For maximum flexibility the SFP mating connector and associated "cage" on the Model 5152's FPGA circuit board were implemented to meet the electrical and mechanical requirements of the MSA SFP standard. The MSA SFP standard was originally developed for use with optical data (Ethernet) modules. It has also become popular for use with SFP modules that support SMPTE-compliant SDI signals.

It's interesting to note that several companies offer non-optical SFP modules that support the MSA SFP standard as well. For example, Embrionix of Canada offers a wide range of specialized SFP modules. These include coaxial SDI input and output modules that use DIN 1.0/2.3 and HD-BNC connectors. In addition, they offer SFP

modules that provide an HDMI® output. Several of these modules have been installed and tested in Model 5152 modules at the factory and acceptable performance was confirmed. It's possible that special applications could benefit from the features provided by installing these non-optical SFP modules in a Model 5152. For further dialog about this topic please contact Studio Technologies technical support.

USB Port Capabilities

The USB port, accessible on the Model 5152's front panel, is provided for use in only a few specific tasks. While it implements a high-speed USB host interface, it is not intended for general-purpose use and does not support connection with mass-storage devices, personal computers, printers, etc. It is intended only for use with USB flash drives. These devices can contain image and firmware files that are intended for loading into the Model 5152. Details on these file-transfer functions can be found in other sections of this guide.

Specifications

SDI Compatibility, Supported Formats and Rates:

HD-SDI per SMPTE ST 292:2011:

720p: 50, 59.94, 60
1080i: 50, 59.94, 60
1080p: 23.98, 24, 25, 29.97, 30
1080psf: 23.98, 24, 25

3G-SDI Level A per SMPTE ST 424:2006 and ST 425:2011:

1080p: 50, 59.94, 60

SD-SDI per SMPTE® ST 259:2008:

Not supported

Audio Embedding into SDI:

Per SMPTE ST 299-1-2010

Coaxial (BNC) SDI Input and Output:

Type: unbalanced

Impedance: 75 ohms

Level: 800 mV p-p, nominal

Optical Input (optional):

Compliance: SMPTE ST 297:2006 (as applicable)

Fiber Type: single mode

Wavelengths Supported: 1250 to 1650 nm

Receive Sensitivity: -17 dBm, nominal @
2.97 Gb/s

Maximum Input Power: -3 dBm, nominal

Optical Output (optional):

Compliance: SMPTE ST 297:2006 (as applicable)

Fiber Type: single mode

Wavelength: 1310 nm (FP laser) or CWDM (DFB laser), as per order

Launch Power: -3 dBm, nominal

Typical Fiber Interconnect Length: 10 km
minimum

Digital Audio Inputs: 4 (2-channel)

Type: AES3, unbalanced, 75 ohms (formerly AES3id)

Sample Rate Range: 32-48 kHz

Maximum Bit Depth: 24

Nominal Level: -20 dBFS or -18 dBFS

Timing: asynchronous, each input contains sample rate conversion (SRC) circuitry

Signal Present LEDs: lights at \geq -40 dBFS

GPI: active low, "pulled up" to 3.3 volts DC using 5 k ohm resistor; activates on closure to common (applies to Model 5152 modules with serial numbers 00251 and later)

GPO: active high, 3.3 volts DC with series resistance of 150 ohm; short circuit current of approximately 22 milliamperes in reference to common (applies to Model 5152 modules with serial numbers 00251 and later)

Remote Control Data Interface: RS-485 115.2 Kb/s, 8-1-N; compatible with Studio Technologies' Model 5190 Remote Access Module

Connectors:

Coaxial SDI Input and Output: BNC, 3G-SDI optimized, gold plating on center pin, per IEC 61169-8 Annex A

Optical Module: MSA-compliant SFP

Digital Audio Input: 1, 9-pin D-subminiature female (DE-9F); requires installer-provided DE-9M, 4-40 hardware

DC Input/Data: 1, 4-position male header. Refer to Appendix B for mating connector details.

GPI/GPO: 1, 3-position male header (applies to modules with serial numbers 00251 and later). Refer to Appendix B for mating connector details.

Power Requirement: 12 volts DC nominal, 400 mA max; acceptable range 10-18 volts DC, 480 mA max at 10 volts

Dimensions (Overall):

3.75 inches wide (9.5 cm)

1.69 inches high (4.3 cm)

2.30 inches deep (5.8 cm)

Mounting: requires custom implementation; no mounting method provided. Refer to Appendix C for details.

Weight: 0.2 pounds (91 g)

Specifications and information contained in this User Guide subject to change without notice.

Appendix A—Model 5152 Versions

The following list describes the available Model 5152 versions along with their respective order codes. List is current as of the publication date of this guide.

Version	Order Code	Figure
Model 5152 Video Generator/Audio Embedder Module	M5152	A
Model 5152 Video Generator/Audio Embedder Module with Optical Output (1310 nm)	M5152-01	B
Model 5152 Video Generator/Audio Embedder Module with Optical Input/Output (1310 nm)	M5152-02	C
Model 5152 Video Generator/Audio Embedder Module with CWDM Optical Output	M5152-03X*	B
Model 5152 Video Generator/Audio Embedder Module with Optical Input/CWDM Output	M5152-04X*	C

* For order codes -03X and -04X, X = the standard CWDM wavelength letter code, e.g., L=1490 nm.

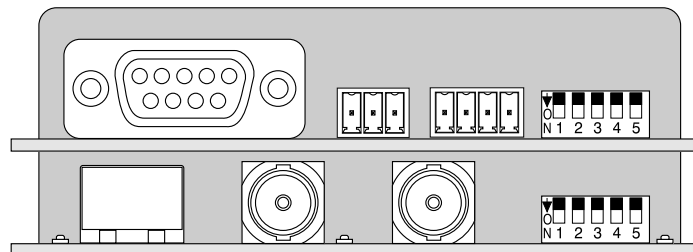

Figure A (No SFP)

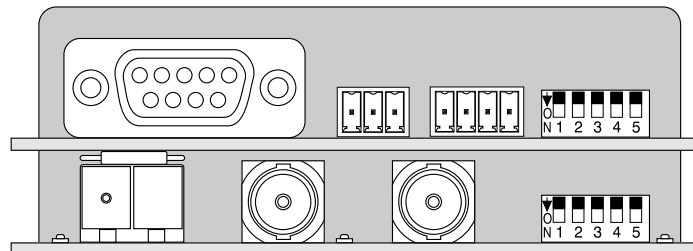

Figure B (Optical-Output-Only SFP)

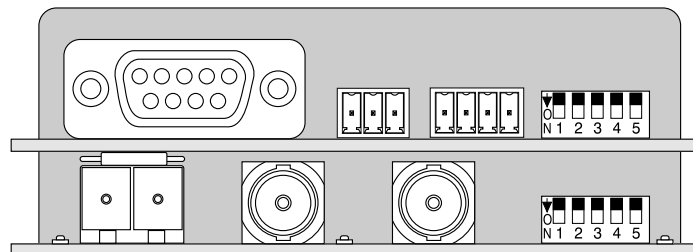

Figure C (Transceiver SFP)

Appendix B—DC Input/Data and GPI/GPO Interconnection Details

The required mating receptacle is from the TE Connectivity (formerly AMP) MTA-100 series of IDC (insulation displacement) connectors. This series was selected because of its low-cost and wide range of offerings. Separate connectors are offered for compatibility with 22, 24, 26, and 28 AWG (American Wire Gauge) insulated wire. The connector color indicates its AWG-compatibility. Unfortunately, with flexibility can come some confusion. The MTA-100 offers a number of different connectors that will work with the DC input/data and GPI/GPO headers. Before obtaining receptacles it's important to determine two things: wire gauge and wiring arrangement. For this application 22 AWG is recommended.

DC Input/Data

- For 22 AWG wire this receptacle (red in color) is recommended:

TE Connectivity (AMP) 3-643813-4, closed-end type

Digi-Key part number A31108-ND

Mouser part number 571-3-643813-4

TE Connectivity (AMP) 3-644540-4, feed-through type

Digi-Key part number A31122-ND

Mouser part number 571-3-644540-4

GPI/GPO

- For 22 AWG wire this receptacle (red in color) is recommended:

TE Connectivity (AMP) 3-643813-3, closed-end type

Digi-Key part number 3-643813-3-ND

Mouser part number 571-3-643813-3

TE Connectivity (AMP) 3-644540-3, feed-through type

Digi-Key part number A31121-ND

Mouser part number 571-3-644540-3

Appendix B—Interconnection Details, continued

Tools for Connecting Wires to the Mating Receptacles, continued

For applications where a larger number of Model 5100-Series modules are going to be installed it's worth considering a semi-automatic termination tool. The recommended tool consists of a handle assembly and crimp die for MTA-100 receptacles. The total price for both, approximately US\$300 as of this writing, is steep but the performance that this tool assembly provides is excellent. We feel that the time savings and reliability of the connections may warrant the price when many terminations are going to be made:

- Handle Tool, Pistol Grip:
 - TE Connectivity (AMP) 58074-1
 - Digi-Key part number A2031-ND*
 - Mouser part number 571-580741*
- Crimp Head Die Assembly for MTA-100 Receptacles:
 - TE Connectivity (AMP) 58246-1
 - Digi-Key part number A1998-ND*
 - Mouser part number 571-58246-1*

Headers on the Model 5152 Printed Circuit Board

The actual part number of the header connectors that are soldered into the Model 5152's printed circuit board is provided in this section. But do not order this part number with the intent of interconnecting signals with the Model 5152! We are providing this detail only so that interested technical personnel can have the full background on the Model 5152's interconnect system. The appropriate mating receptacle is detailed in a previous section of this Appendix.

- DC Input/Data:
 - TE Connectivity (AMP) 2-644486-4 (**DO NOT ORDER THIS NUMBER!**)
- GPI/GPO:
 - TE Connectivity (AMP) 2-644486-3 (**DO NOT ORDER THIS NUMBER!**)

Appendix C—Model 5152 Front Panel and Printed Circuit Board (PCB) Dimensions

STUDIO TECHNOLOGIES, INC.
MODEL 5100-SERIES SINGLE-WIDTH FRONT PANEL
AND PRINTED CIRCUIT BOARD DIMENSIONS
(DIMENSIONS SHOWN IN INCHES)
(AS OF JUNE 2013, APPLIES TO
MODELS 5110, 5120, 5121, 5130, 5132, 5134, 5150, 5152, 5162, 5180, AND 5190)

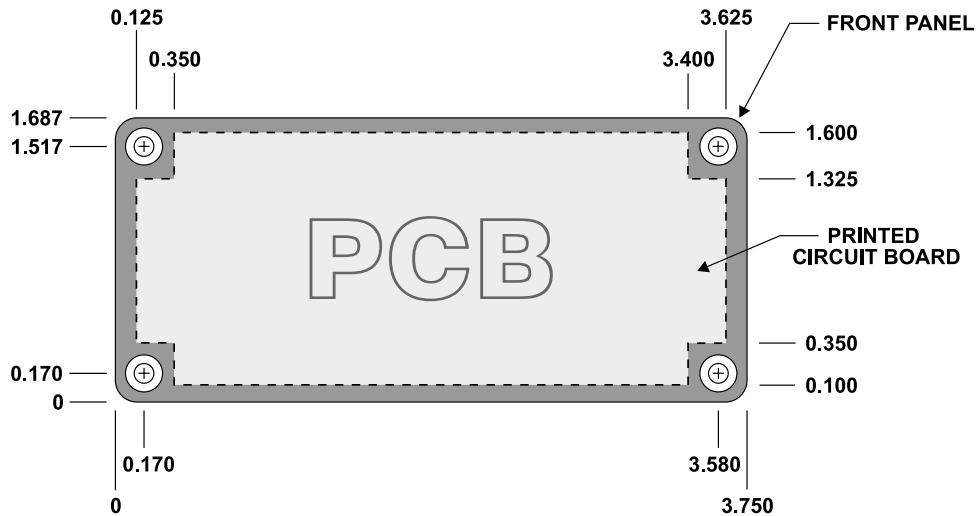

NOTES:

- 1) OPENING MUST BE MADE IN CUSTOM-MOUNTING ARRANGEMENT SO THAT PCB IS ALLOWED TO FREELY PASS THROUGH.
- 2) FRONT-PANEL MOUNTING LOCATIONS DIMENSIONED FOR #4 COUNTERSUNK SCREWS (4 PLACES). UNDERCUT FLAT-HEAD MACHINE SCREWS RECOMMENDED.
- 3) RECOMMENDED MOUNTING-HOLE LOCATIONS SHOULD BE DRILLED AND TAPPED FOR 4-40 SCREW THREADS (4 PLACES).

WARNING:
THIS DRAWING SHOWS THE DIMENSIONS OF THE PRINTED CIRCUIT BOARD.
PANEL OPENING MUST BE MADE LARGER TO ALLOW PCB TO PASS THROUGH!
CONTACT FACTORY IF YOU HAVE QUESTIONS.

