

Model 545AR Intercom Interface

User Guide

Issue Preliminary 1, October 2024

This User Guide is applicable for serial numbers
M545AR-00151 and later with Application Firmware 2.1 and later

Copyright © 2024 by Studio Technologies, Inc., all rights reserved
studio-tech.com

This page intentionally left blank.

Table of Contents

Revision History	4
Introduction.....	5
Getting Started	8
Operation.....	12
Technical Notes.....	16
Specifications	21
Appendix A–Interfacing RTS® Matrix Intercom Systems and RVON-I/O with the Model 545AR Intercom Interface	23
Appendix B–Interfacing Riedel® Artist™ Matrix Intercom System Analog Ports with the Model 545AR Intercom Interface.....	24
Appendix C– Interfacing Clear-Com® Matrix Intercom System Analog Ports with the Model 545AR Intercom Interface.....	25
Appendix D–Graphical Description of the Installation Kit for Panel Cutout or Surface-Mounting Use (Order Code: RMBK-10)	26
Appendix E–Graphical Description of Left- or Right-Side Rack-Mount Installation Kit for One “1/2-Rack” Unit (Order Code: RMBK-11).....	27
Appendix F–Graphical Description of Rack-Mount Installation Kit for Two “1/2-Rack” Units (Order Code: RMBK-12).....	28
Appendix G–Graphical Description of Center Rack-Mount Installation Kit for One “1/2-Rack” Unit (Order Code: RMBK-13)	29

Revision History

Issue Preliminary 1, October 2024:

- Initial preliminary release.

Introduction

The Model 545AR is designed to interface 2-wire full-duplex party-line (PL) intercom circuits with 4-wire audio circuits associated with analog audio equipment. These devices include audio consoles, matrix intercom systems, wireless intercom systems, fiber-optic transport units, and Internet streaming units. Applications for the Model 545AR include television sports and live-event broadcasting, theme park and theater installations, corporate AV, and industrial testing environments. The unit provides one full-featured 2-channel 2-wire-to-4-wire interface. The interface features hybrid circuitry that includes automatic “nulling” capability. The analog hybrids, under software control, provide excellent audio quality and high return-loss.

The Model 545AR is powered by an external source of 12 volts DC. The circuitry is designed so that full isolation from the connected party-line circuit is maintained. The unit can be directly connected to a party-line circuit which provide DC power and audio terminations. For maximum flexibility, the unit is also capable of supplying 28 volts DC power with 200 ohm intercom audio terminations, thus creating a 2-channel 2-wire party-line intercom circuit. This allows direct support for devices such as intercom belt packs and user interfaces.

Audio level meters provide user confirmation of system performance during setup and operation. Standard audio connectors are used for interfacing

audio input, audio output, party-line intercom, and DC power signals. The unit’s lightweight aluminum enclosure is intended for desk or tabletop use. The compact “1/2-rack” form factor meets the needs of broadcast “throw-down” applications. Optional mounting kits allow one or two Model 545AR units to be mounted in one space (1U) of a standard 19-inch rack enclosure.

2-Wire Party-Line Interface

The Model 545AR’s 2-channel 2-wire party-line interface is optimized for direct connection with a dual-channel party-line intercom circuit. The unit’s 2-wire interface is configured for a –10 dBu nominal level, matching that of the popular RTS® TW-series of analog party-line intercom products.

The Model 545AR’s 2-wire party-line interface can be directly connected to a powered 2-channel party-line intercom circuit. This type of party-line circuit has power present, normally 28-32 volts DC, which provides energy for connected devices such as analog belt packs and smaller user stations. In this scenario, the Model 545AR’s circuitry will appear as a standard analog user device, maintaining a high-impedance load on the two audio channels and drawing no DC power.

Alternately, the Model 545AR’s 2-wire party-line interface has the ability to create a fully functioning 2-channel 2-wire party-line intercom circuit, supplying the required DC power and 200 ohms AC terminations. Referred to as the Model 545AR’s local power mode, it provides a 28 volts DC, 300 milliampere



Figure 1. Model 545AR Intercom Interface front and back views

maximum output which can power devices such as user belt packs. In many applications, this will eliminate the need for an external intercom power supply. Besides reducing total system cost, this feature can also lower system weight, reduce the required mounting space, and decrease the mains energy requirement.

With the 2-wire interface's ability to supply up to 300 milliamperes of current a typical broadcast application which uses up to four of the RTS BP-325 belt packs can easily be supported. The circuitry's output regulation is such that little change in the 28 volts output voltage will occur over its entire rated output current. The local power source is an industry-standard 28 volts DC, helping to ensure that applications requiring long intercom cable runs will function correctly. Also, the design of the power supply circuitry helps to minimize the noise and "hiss" often associated with intercom power supplies. Under software control the local DC power supply's output is monitored for over-current and short-circuit conditions. This allows protection shut-down of the output, as well as providing an alert by way of a visual indicator.

An auto-terminate function ensures that should a party-line circuit not be connected, the Model 545AR's interface circuitry will remain stable. This unique feature makes certain that objectionable audio signals, such as oscillations and "squeals," will rarely be sent to the connected 4-wire device. To support special applications, this function can be disabled with a button-press sequence.

Analog Hybrids with Auto Nulling

A key reason that the Model 545AR achieves excellent audio performance is the design of its 2-wire-to-4-wire hybrid circuits. Each of the two independent circuits provides low noise and distortion, good frequency response, and high return-loss (separation of send and receive audio or "nulling"), even when presented with a wide range of 2-wire party-line conditions. Unlike telephone-line ("POTS") oriented DSP-based hybrid circuits, the Model 545AR's analog circuitry provides extended frequency response. With a pass band of 100 Hz on the low end and 8 kHz on the high end, natural-sounding voice signals can be sent to, and received from, the party-line circuit.

A hybrid's ability to isolate the transmit signal from the receive signal in the 2-wire-to-4-wire interface is critical. The quality of this isolation, technically known

as return-loss or trans-hybrid loss, is measured in dB. A high value is important, especially in applications where multiple 2-wire-to-4-wire interfaces are used together. Remote sports broadcast applications are especially sensitive to this requirement. The Model 545AR's sophisticated auto nulling function uses analog circuitry under microprocessor control to achieve significant trans-hybrid loss. This return-loss null is achieved by making a set of adjustments to account for the resistive, inductive, and capacitive conditions that are present on the connected 2-wire party-line circuit. The party-line's conditions are the sum of the impact made by the type and quantity of cable, the connected user devices, and the intercom power source.

Whenever a user presses the Model 545AR's auto null pushbutton switch, digital circuitry adjusts the analog hybrids to achieve their maximum return-loss. The nulling process takes less than 15 seconds for both interface channels. It's important to highlight that while the nulling process is automatic, it only takes place upon user request. The parameters obtained during the nulling process are stored in non-volatile memory; power interruptions won't require the auto nulling function to be performed again.

The Model 545AR generates a sine wave audio tone for use during the auto nulling process. The signal's frequency is software-controlled to maximize the ability of the hybrid circuits to reach a "deep" null. In addition, at the beginning of each auto nulling sequence, a short period of 24 kHz tone is sent to the associated channel of the 2-wire party-line interface. This serves as a microphone disable ("mic kill") signal for user devices such as the RTS BP-325 user belt pack. By automatically disabling "open" microphones the auto nulling process can achieve a better result.

4-Wire Interfaces

Associated with the 4-wire portion of the Model 545AR's dual-channel interface are analog line-level inputs and outputs. These are intended to interconnect with a variety of 4-wire devices, including matrix intercom systems, audio consoles, audio-over-fiber transmission systems, and specialized audio equipment. The 4-wire input and output circuitry is transformer-coupled to minimize the chance of hum, noise, or ground "loop" issues. The nominal input and output levels are +4 dBu, helping to ensure

compatibility with professional audio equipment. Some digital matrix intercom systems use other nominal levels but with their configuration flexibility they can be easily adjusted to match the Model 545AR. For example, the Riedel Artist® system has a nominal level of +6 dBu so an adjustment of only 2 dB is required. The RTS ADAM™ series of matrix intercom systems have a nominal level of +8 dBu. This level also applies to their RVON-I/O VoIP products. As such, reducing their nominal input and output levels by 4 dB will ensure optimal compatibility.

The Model 545AR contains four 5-segment LED level meters with two displaying the level of the signals being received on the 4-wire inputs and two displaying the level being sent out the 4-wire outputs. During installation and setup, the meters can be invaluable in helping to confirm that proper operation is taking place. The meters are also useful during normal operation, allowing confirmation of audio signal flow into and out of the Model 545AR.

Pro Audio Quality

The Model 545AR's audio circuitry was designed in the spirit of professional audio equipment, rather than that found in typical party-line intercom gear. High-performance components are used throughout, providing low distortion, low noise, and high headroom. Using passive and active filters, the frequency response is limited to nominally 100 Hz to 8 kHz. This range was selected to provide excellent performance for human speech, while maximizing the ability of the hybrids to create substantial nulls. When the Model 545AR's local (internal) power source is selected to provide 2-wire party-line intercom power, enhanced audio performance can also be expected. The quality of the local DC supply circuit is very good, with very little noise, hum, or "hiss" being added to the 2-wire connection. In addition, the impedance characteristics of the interface's DC powered ("wet") channel was tailored to be essentially identical to that of the un-powered ("dry") channel. This unique situation allows the automatic nulling circuitry to provide excellent, consistent results for both the powered and un-powered channel.

Attention to detail is a hallmark of the Model 545AR's design. For example, during the brief auto nulling process the interface channel's 4-wire output signals are normally muted, preventing unwanted audio from

reaching the connected equipment. Associated with the 2-wire party-line interface is circuitry that, under software control, applies 200 ohm terminating impedances to the 2-wire party-line circuit. This, along with other circuitry that monitors DC voltages present on pin 2, ensures that audio instability associated with unterminated circuits will rarely occur.

Simple Installation

The Model 545AR uses standard 3-pin XLR connectors to allow convenient 2-wire party-line and 4-wire interconnection in broadcast and general-audio environments. For flexibility, access to the 2-wire party-line intercom interface can be made using either a male or female XLR connector on the back panel or a male XLR connector on the front panel.

The Model 545AR is powered by an external source of 12 volts DC. A compact, lightweight 12 volts DC output power source is supplied with each unit. The power supply's universal mains input capability (100-240 volts, 50/60 Hz) allows operation virtually anywhere in the world. The power supply's DC output is terminated on a 4-pin female XLR connector, allowing direct connection to the Model 545AR's DC power input receptacle.

Four LED meters make it simple to confirm operation of the connected 4-wire inputs, 4-wire outputs, and 2-wire party-line circuit. Additional LED status indicators are also provided, offering a clear view of the 2-wire DC power source, auto null functions, and input operating power.

The Model 545AR is housed in a rugged, lightweight aluminum enclosure that is designed to be "road tough." The "1/2-rack" unit is ready for portable or stand-alone "thrown-down" applications. Optional mounting kits are available, allowing one or two units to be mounted in one space (1U) of a standard 19-inch rack enclosure, wall-mounted, or installed in a panel cutout.

Design Philosophy

While the "bits and pieces" that make up the Model 545AR have been described in conventional terms, the real strength of the unit rests in the way it integrates and performs in the "real world." Studio Technologies learned from conversations with industry experts that installing and configuring 2-wire-to-4-wire interface equipment has traditionally been a time-

consuming, aggravating process, requiring the efforts of an expert to achieve reasonable results. Even under those constraints, the resulting audio performance was often mediocre. This “history lesson” made it clear that any new design had to start with a unique set of requirements. This led to an overriding design goal: create a “new breed of cat,” fundamentally changing how broadcast 2-wire-to-4-wire interface equipment fits into actual applications.

An important first step was to eliminate the requirement that a senior technician, along with a screwdriver, be present during every installation. (It was universally acknowledged that their time can be better spent elsewhere!) The need to adjust trim potentiometers, fabricate special cabling and connector straps, use nulling earpieces, etc. had to be eliminated. For example, in virtually all instances, input and output levels fall within just a few dB of their nominal values and, as such, could be supported with one industry-standard nominal audio level. In addition, it was acknowledged that in this application analog audio circuitry was capable of providing excellent audio performance, but that the required manual nulling process was operationally taxing. By adding digital control to the analog circuitry, automatic nulling could be performed—the best of both worlds!

The next step was to identify resources that would improve the installation process and make operation more reliable. This led to the use of standard 3-pin XLR audio connectors, enabling rapid installation and troubleshooting in any locale. The inclusion of LED level meters allowed continuous monitoring of the input and output signals. Additional status LEDs were also deemed to be valuable.

In many applications, a small number of user devices, such as belt packs, would be connected to a 2-wire party-line circuit. To address this need, the Model 545AR incorporates a local DC power source associated with the 2-wire interface, often eliminating the need for an external intercom power supply to be utilized.

The final step was to create a physical package that would provide significant resources in a format that allowed simple and reliable integration with other equipment. This was accomplished by specifying a convenient “1/2-rack” form factor which would be excellent for “thrown-down” use. By creating mounting

kits, it would be possible to allow flexible installation opportunities, including being able to mount one or two Model 545AR units in one space of a 19-inch rack.

Getting Started

In this section, a location will be selected for the Model 545AR. If desired, an optional installation kit will be used to allow the unit to be mounted into a panel cut-out, a wall surface, or an equipment rack. A source of 12 volts DC power will be connected to the unit’s 4-pin XLR connector. Signal interconnections will be made using the unit’s multiple 3-pin XLR connectors. This can include connecting to an existing party-line intercom circuit. Alternately, wiring to support one or more analog party-line belt packs can be performed. Connections to analog 4-wire audio inputs and outputs will also be made.

What’s Included

Included in the shipping carton are a Model 545AR Intercom Interface, a PS-DC-02 (universal AC mains input/12 volts DC output) power supply, and instructions on how to obtain an electronic copy of this guide. A North-American standard AC mains power cord will be provided for use with the power supply. If necessary, a reseller or distributor will provide an alternate AC mains cord that is appropriate for your location. An optional installation kit allows a Model 545AR to be mounted in a rectangular opening in a tabletop or attached to a flat surface. If one or two Model 545AR units are going to be mounted in a 19-inch equipment rack then having one of the optional rack-mount installation kits is required. If an installation kit was purchased it would typically have been shipped in a separate carton.

Locating the Model 545AR

Where to locate a Model 545AR will typically depend on being able to access the associated party-line circuit or deploying the wiring necessary to support the desired user belt pack devices. Access to an AC mains outlet, required by the 12 volts DC power supply, can also dictate the Model 545AR’s location. The Model 545AR is shipped as a self-contained “throw-down” unit suitable for portable use or placement in a semi-permanent location. Installed on the bottom of the chassis are “bump on” protectors (also known as rubber “feet”). These are useful if the unit is going to be placed on a surface where scratching of either

the Model 545AR's enclosure or the surface material could take place. However, if applicable the "feet" can be removed when the unit's installation is going to be performed in a panel cutout, a flat surface, or a rack enclosure.

The location selected for the Model 545AR will dictate the length of the cable "runs" needed to link the unit with the other related intercom devices. This factor really only relates to the connection that's made to the party-line intercom circuit. This type of circuit carries unbalanced audio which can be susceptible to interference and crosstalk issues. And since party-line intercom circuits carry DC power a voltage drop due to resistive loss in the cable can become an issue. In general, minimizing the length of a party-line intercom cable will help to ensure more reliable and consistent intercom system performance. The connections to the 4-wire analog audio circuits are typically balanced (differential) and are not normally impacted by the length of their interconnecting cables. A final location criterion is to provide access to the Model 545AR's front panel. An optimal location will allow convenient use of the auto null pushbutton and easy observation of the level meter and status LEDs.

Mounting Options

Panel Cutout or Surface Mounting One Model 545AR Unit

Installation kit RMBK-10 allows one Model 545AR to be mounted in a panel cutout or onto a flat surface. The kit contains two standard-length brackets and four 6-32 thread-pitch Phillips-head machine screws. Refer to Appendix D for a visual explanation.

Begin installation of the kit by removing the four "bump on" protectors from the bottom of the Model 545AR's chassis. They are removed using the fingers to rotate them counterclockwise; no tool is required. Store the four "bump on" protectors for possible later use.

Next use a #2 Phillips screwdriver and two 6-32 machine screws to attach one of the standard-length brackets onto the left side (when viewed from the front) of the Model 545AR's enclosure. Orient the standard-length bracket such that its front is parallel to the Model 545AR's front panel. The screws will mate with the threaded fasteners that can be seen on the side of the Model 545AR's enclosure, near the front of the unit. Using two additional 6-32 machine screws,

attach the other standard-length bracket onto the right side of the Model 545AR's enclosure.

Once the two standard-length brackets have been installed the Model 545AR will be ready to be mounted into an opening. Secure the unit into the left and right sides of the opening using two screws per side.

To prepare the unit to be mounted onto a flat surface simply requires the standard-length brackets be attached to the Model 545AR at 90 degrees from how they are mounted for use in a panel cutout. Use a #2 Phillips screwdriver and two 6-32 machine screws to attach one of the standard-length brackets onto the left side (when viewed from the front) of the enclosure. Orient the bracket such that its front is parallel with the top surface of the Model 545AR's enclosure. The screws will mate with the threaded fasteners that can be seen on the side of the Model 545AR's enclosure, near the front of the unit. Use two additional 6-32 machine screws to attach the other standard-length bracket onto the right side of the Model 545AR's enclosure.

Once the two standard-length brackets have been installed the Model 545AR will be ready to be mounted onto a flat surface. Secure the unit to the surface using two screws per side.

Left- or Right-Side Rack Mounting One Model 545AR Unit

Installation kit RMBK-11 allows one Model 545AR to be mounted into the left or right side of one space (1U) of a standard 19-inch rack enclosure. The kit contains one standard-length bracket, one long-length bracket, and four 6-32 thread-pitch Phillips-head machine screws. Refer to Appendix E for a visual explanation.

Get ready to install the kit by first removing the four "bump on" protectors from the bottom of the Model 545AR's chassis. They are removed by using the fingers to rotate them counterclockwise; no tool is required. Store the four "bump on" protectors for possible later use.

To allow the unit to be mounted on the left side of the rack enclosure, use a #2 Phillips screwdriver and two 6-32 machine screws to attach the standard-length bracket onto the left side (when viewed from the front) of the enclosure. The screws will mate with the threaded fasteners that can be seen on the side of the Model 545AR's enclosure, near the front of the unit.

Using two additional 6-32 machine screws, attach the long-length bracket onto the right side of the Model 545AR's enclosure.

To allow the unit to be mounted on the right side of a rack enclosure simply install the standard-length bracket onto the right side of the enclosure. The long-length bracket should be mounted onto the left side of the enclosure.

Once the standard-length and long-length brackets have been installed onto the Model 545AR's enclosure the unit will be ready to be mounted into the designated equipment rack. One space (1U or 1.75 vertical inches) in a standard 19-inch equipment rack is required. Secure the unit into the equipment rack using two screws per side.

Rack-Mounting Two Model 545AR Units

Installation kit RMBK-12 is used to allow two Model 545AR units to be mounted in one space (1U) of a standard 19-inch equipment rack. The kit can also be used to rack-mount one Model 545AR and one other Studio Technologies' RMBK-12-compatible product, such as the Model 5421 Dante Intercom Audio Engine. The RMBK-12 installation kit contains two standard-length brackets, two joiner plates, eight 6-32 thread-pitch Phillips-head machine screws, and two 2-56 thread-pitch Torx™ T7 thread-forming machine screws. Refer to Appendix F for a visual explanation.

Get ready to install the kit by removing the four "bump on" protectors from the bottom of each chassis. They are removed by using the fingers to rotate them counterclockwise; no tool is required. Store the eight "bump on" protectors for possible later use.

With assistance from a #2 Phillips screwdriver, use two of the 6-32 machine screws to attach one of the standard-length brackets onto the left side (when viewed from the front) of one of the Model 545AR units. The screws will mate with the threaded fasteners that can be seen on the side of the Model 545AR's enclosure, near the front of the unit. Using two more of the 6-32 machine screws, attach one of the joiner plates onto the right side of that same Model 545AR unit.

Again using two of the 6-32 machine screws, attach the second standard-length bracket onto the right side of the second Model 545AR or another compatible unit. Using the final two 6-32 machine screws, attach

the second joiner plate onto the left side of the second Model 545AR or other compatible unit with an orientation of 180 degrees from the way in which the first plate was installed.

To complete the assembly, "join" the units together by sliding each joiner plate through the other. The grooves in each joiner plate will carefully align with each other and form a relatively tight bond. Line up the two units so that the front panels form a common plane. With the aid of a Torx T7 screwdriver, use the two 2-56 Torx machine screws to secure the two joiner plates together. The screws should fit snugly into the small openings formed by the mating of the two joiner plates.

The 2-unit assembly is now ready to be mounted into the designated equipment rack. One space (1U or 1.75 vertical inches) in a standard 19-inch equipment rack is required. Secure the assembly into the equipment rack using two screws per side.

Center Rack Mounting One Model 545AR Unit

Installation kit RMBK-13 allows one Model 545AR to be mounted in the center of one space (1U) of a standard 19-inch rack enclosure. The kit contains two medium-length brackets and four 6-32 thread-pitch Phillips-head machine screws. Refer to Appendix G for a visual explanation.

Begin the installation by removing the four "bump on" protectors from the bottom of the Model 545AR's chassis. They are removed by using the fingers to rotate them counterclockwise; no tool is required. Store the four "bump on" protectors for possible later use.

To prepare the unit to mount in the center of a rack enclosure, use a #2 Phillips screwdriver and two 6-32 machine screws to attach one of the medium-length brackets onto the left side (when viewed from the front) of the enclosure. The screws will mate with the threaded fasteners that can be seen on the side of the Model 545AR's enclosure, near the front of the unit. Using two additional 6-32 machine screws, attach the other medium-length bracket onto the right side of the Model 545AR's enclosure.

Once the two medium-length brackets have been installed the Model 545AR will be ready to mount into the designated equipment rack. One space (1U or 1.75 vertical inches) in a standard 19-inch equipment

rack is required. Secure the unit into the equipment rack using two screws per side.

Connecting 12 Volts DC

A source of 12 volts DC, 1.0 amperes maximum, must be connected to the Model 545AR by way of the 4-pin male XLR connector which is located on the unit's back panel. A Studio Technologies' PS-DC-02 power supply is provided in the shipping carton. Its AC mains input allows connection to 100-240 volts, 50/60 Hz and has a 12 volts DC, 1.5 amperes maximum output that is terminated on a 4-pin female connector. It can be directly connected to the Model 545AR.

While the stated requirement for the external source is nominally 12 volts DC, correct operation will take place over a 10 to 16 volts DC range. The Model 545AR requires a maximum current of 1.0 amperes for correct operation. The DC source should be terminated on a 4-pin female XLR connector with pin 1 negative (-) and pin 4 positive (+); pins 2 and 3 should remain unterminated.

Party-Line Intercom Connections

The Model 545AR's party-line intercom interface is designed to function in two distinct ways. It can be connected to a "powered" broadcast-standard 2-channel party-line intercom circuit. Alternately, it can be connected directly to party-line intercom user devices. A 2-channel party-line intercom circuit, such as one associated with TW-series equipment from RTS, will have DC power and two audio channels on a 3-pin XLR connector. These connectors will be wired such that common is on pin 1 and 28 to 32 volts DC is on pin 2. Channel 1 audio is superimposed on the DC present on pin 2 while channel 2 audio is present on pin 3. The party-line intercom circuit will also include impedance-generating networks that provide 200 ohms audio (AC) resistance from pin 2 to pin 1 (audio channel 1) and from pin 3 to pin 1 (audio channel 2). When the Model 545AR's party-line interface is connected to an existing intercom circuit it will act, from an audio standpoint, as a standard party-line intercom user device. It won't draw (nor supply) any DC power, nor will it provide additional 200 ohms audio impedance networks.

The Model 545AR's party-line interface can also serve to create a "mini" 2-channel intercom circuit. It can provide a 28 volts DC, 300 milliamperes maximum,

power source along with two 200 ohms impedance generators. This relatively modest amount of current will allow a limited number of 2-channel intercom user devices to be directly connected. Many broadcast applications use the popular RTS BP-325 user beltpack and the Model 545AR's intercom interface can directly support up to three of them. Wiring from the Model 545AR's intercom interface to one or more of the BP-325 devices requires that a 1-to-1, 2-to-2, 3-to-3 wiring scheme on associated 3-pin XLR connectors be maintained.

For convenience, the party-line intercom circuit and/or user devices can connect to the Model 545AR by way of the male and female 3-pin XLR connectors that are located on the unit's back panel. The two connectors are wired in parallel ("malted") and provide access to the identical signals.

Compatibility with Single-Channel Intercom Systems

As previously discussed, the Model 545AR is designed to directly support 2-channel party-line intercom circuits and user devices. Applications that involve single-channel party-line intercom circuits and user devices (typically associated with products from Clear-Com®) can also be supported. These circuits and devices typically utilize common on pin 1, DC power on pin 2, and intercom audio on pin 3. When this kind of intercom circuit is directly connected to the Model 545AR's intercom interface, only the unit's channel 2 will be active; channel 1 would not be utilized.

A better means to support these single-channel party-line intercom circuits and user devices is to use the Studio Technologies' Model 545AC Intercom Interface unit. This unit is a "cousin" of the Model 545AR and optimized for single-channel party-line intercom applications. Rather than providing a single 2-channel interface, this unit provides two single-channel-optimized party-line intercom interfaces. Detailed information about this unit is available on the Studio Technologies' website (studio-tech.com).

Analog 4-Wire Audio Inputs and Outputs

Two audio line input and two audio line output signals are associated with the Model 545AR's 4-wire interfaces. Connections are made using standard 3-pin

male and female XLR connectors. Refer to Appendices A, B, and C for details on interconnecting with RTS, Riedel, and Clear-Com matrix intercom systems.

Analog 4-Wire Audio Inputs

As previously mentioned, the Model 545AR's 4-wire interface allows two analog line-level audio sources to be connected. The source for these signals will typically be ports on a matrix intercom system. It's also possible that the signals will come from other devices, such as a fiber optic or copper-based audio transmission system. The 4-wire input circuitry is balanced, capacitor coupled, transformer isolated, and has an impedance of approximately 11 k ohms. The line inputs are optimized for signals that have a nominal level of +4 dBu.

Audio sources are connected to the line inputs by way of 3-pin female XLR connectors which are located on the Model 545AR's back panel. Refer to Figure 1 for a detailed view.

Prepare the mating connectors (males) so that XLR pin 2 is signal high (+ or hot), pin 3 is low (– or cold), and pin 1 is shield. If connecting a source in this manner results in hum or noise it's possible that removing the shield connection from pin 1 can eliminate the issue; “floating” pin 1 will remove a ground current path from the Model 545AR's chassis ground point through the shield of a cable. (Pin 1 on each of the two input connectors is internally connected to the Model 545AR's earth/chassis ground point.) If a hum- or noise-issue does arise be certain to confirm that, unless absolutely necessary, the mating connector's “shell” isn't connected to the cables' shield or pin 1. Termination of this “fourth” pin of a 3-pin XLR connector is often the cause of seemingly inexplicable noise issues.

With an unbalanced source, connect XLR pin 2 to signal high (+ or hot) and both pins 1 and 3 to shield. If connecting an unbalanced source in this manner results in hum or noise, connect XLR pin 2 to high (+ or hot) and pin 3 to shield; leave pin 1 unterminated.

Analog 4-Wire Audio Outputs

The Model 545AR provides two analog line-level audio outputs. These outputs are intended to be connected to inputs on the devices associated with the 4-wire audio signals. The outputs are capacitor-coupled, transformer balanced with a nominal level of

+4 dBu. The 4-wire line outputs are capable of driving inputs that have impedances as low as 600 ohms, however connecting to loads of 2 k ohms or greater is preferred. The line outputs are connected by way of 3-pin male XLR connectors which are located on the Model 545AR's back panel. Refer to Figure 1 for a detailed view.

The mating connectors (females) should be prepared so that signal high (+ or hot) is expected on XLR pin 2. Signal low (– or cold) should be expected on XLR pin 3. The cables' shields can be connected to XLR pin 1. However, in order to minimize the chance that ground-interaction problems will arise, pin 1 on each of the line output connectors is isolated from all Model 545AR circuitry and ground points. “Floating” pin 1 virtually eliminates the chance that a “ground loop” problem will occur.

Operation

The Model 545AR is designed for continuous operation with no internal adjustment, calibration, or maintenance required. An LED, labeled Input Power and located on the left side of the front panel, will light whenever a source of DC power is connected and is powering the unit. The acceptable input power range is 10 to 16 volts DC. A pushbutton switch, also located on the front panel, allows the user to select the on/off status of the local (internal) party-line (PL) power source as well as activating the auto null function. For special applications, the pushbutton switch is also used to select the unit's PL Active Detection operating mode.

The auto null function should be used whenever the number of connected user devices changes, a different party-line intercom circuit is used, or significant changes are made to the amount or type of cabling that is connected to the unit's party-line interface. Activating the auto null function is simple, only requiring momentarily pressing (tapping) the auto null pushbutton switch.

Depending on how the Model 545AR is going to be used, the local party-line power source can be enabled or disabled. It would be enabled whenever user belt-packs are going to be connected to the Model 545AR's party-line interface. An under-voltage shut-down function will help to protect the local party-line power supply should a fault condition be detected. The

local power source should be turned off whenever the Model 545AR is going to be connected to an existing party-line intercom circuit that includes power and audio terminations.

The nominal audio level on the two party-line channels is -10 dBu. The 4-wire audio input and output circuits have a nominal level of $+4$ dBu. Maintaining the correct levels coming from the audio sources that are connected to the 4-wire audio inputs is very important. This will ensure that proper signal levels are presented to party-line users and that optimal audio fidelity is maintained. Also on the unit's front panel are four audio level meters, the local power status LED, and the active status LED indicators. They will assist users in confirming that correct operation is taking place.

Connection of Party-Line Devices

The auto null pushbutton switch and local power status LED are associated with the Model 545AR's local (internal) party-line power source and intercom termination networks. Pressing and holding the auto null pushbutton switch for approximately two seconds will "toggle" (alternate) between the local power on and the local power off conditions. When the local power LED is lit, 28 volts DC will be applied to pin 2 of the back-panel 3-pin male and female XLR connectors designated for party-line connection. These two connectors are connected in parallel (bridged). In addition, intercom audio terminations (AC loads of 200 ohms) will be connected to the two party-line intercom channels. (Technically, independent nominal 200 ohms AC-coupled loads are connected to the two XLR connectors; pin 2 to pin 1 for channel 1 and pin 3 to pin 1 for channel 2.) If user backpack devices are to be directly connected and powered by the Model 545AR's party-line interface, the local power function must be enabled.

If the Model 545AR's party-line intercom interface is to be connected to an existing party-line intercom circuit, the unit's local power source should be turned off. In this mode, the local power LED will not be lit, 28 volts DC will not be applied to pin 2 of the two party-line connectors, and 200 ohms audio termination circuits will not be connected from pin 2 to pin 1 and from pin 3 to pin 1 of the party-line intercom connectors.

If the Model 545AR's local power source is enabled when the unit's party-line interface is connected to

an existing party-line intercom circuit no damage will result. But the audio levels will no longer be correct as each of the two intercom channels will be "double terminated." The Model 545AR's 200 ohms termination circuits will be active at the same time as those of the external intercom circuit. In this situation, the intercom channel termination will drop to approximately 100 ohms and the audio level will drop by approximately 6 dB. This will most likely cause audio level issues for users as well as preventing satisfactory Model 545AR auto nulling from being able to take place.

Local Power Operation

When the Model 545AR's local power source is enabled, the unit will provide DC power and two 200 ohms termination impedances to create a 2-channel party-line intercom circuit. The party-line interface supplies 28 volts DC on pin 2 of the 3-pin XLR connectors with a maximum current draw of 300 milliamperes (mA). This current is sufficient to power various intercom user devices such as small user stations and backpacks. A common broadcast application may use RTS BP-325 backpacks. Select the connected devices so that their total maximum current doesn't exceed 300 mA. That's not always the easiest figure to calculate but a web search will generally find specifications for all commonly used devices. For example, a search finds that the original (very, very early) version of the BP-325 consumes a maximum of 85 mA of current. According to this figure, up to three of these units can be connected to a Model 545AR. All newer versions of the BP-325 use surface-mount component technology and have a maximum current draw of 65 mA. Up to four of these "modern" BP-325 units can easily be supported.

When local power has been enabled, the local power LED will be lit. In addition, the active status LED will light when a minimal amount of current is flowing from the Model 545AR to the connected user device or devices. This current, 5 mA nominal, provides a party-line power source-active signal to the Model 545AR's firmware, indicating that normal operation is taking place. The firmware, in turn, will cause the active status LED to light and the two 4-wire audio output channels to be in their active (unmuted) state. (By muting the 4-wire audio output channels when the intercom circuit is not active, unwanted audio signals will be prevented from passing to the outside world when no party-line devices are connected.)

Note that a mode can be selected to disable the requirement that a current draw of 5 mA (nominal) or greater on pin 2 of the party-line XLR connectors is required for the active status LED to light and the two 4-wire audio outputs to be active. This function is called PL Active Detection and disabling it can be appropriate for special applications. Refer to the Technical Notes section for details regarding this function and how it may be utilized.

The Model 545AR's local power supply circuit operates under firmware control. This allows detection of fault conditions and protection of the unit's circuitry. Upon initially enabling the Model 545AR's local power supply no monitoring of the DC output takes place for three seconds. This allows the Model 545AR's intercom power supply circuitry and the connected intercom user device or devices to stabilize. The local power status LED will be lit solid and the active status LED, which responds to the status of the DC voltage on pin 2 of the party-line interface's 3-pin XLR connectors, will light to indicate that the DC output is active. After this initial delay, monitoring becomes active. A fault condition is detected if the voltage on pin 2 falls below 24 for a continuous 1-second interval. The firmware responds to this condition by momentarily turning off the local power source. It will also, as a warning, flash the active status LED. After a 5-second "cool-down" interval the local power DC output will return to the same condition as upon initial power up; power is again applied to pin 2 and the active LED will light green. Monitoring won't begin for another three seconds. A full short-circuit condition applied to the Model 545AR's party-line circuit will result in a continuous cycle of four seconds on (three seconds for startup and one second for detection) and then five seconds off.

External Party-Line Circuit Operation

When the local power status LED on the front panel is not lit the Model 545AR's party-line interface does not provide DC power on pin 2 of the XLRs, nor does it provide 200 ohms terminating impedances on pins 2 and 3. In this condition, the Model 545AR is intended to be connected to an externally powered party-line circuit. This party-line circuit must provide the DC power and the terminating impedances required to create the 2-channel party-line intercom circuit. In this condition, the Model 545AR will serve in the same fashion

as that of another connected user device. (In effect, the Model 545AR would have the technical characteristics of a typical user device.) When connected to a powered party-line circuit, the Model 545AR's active status LED will light when approximately 18 volts DC or greater is present on pin 2 of the party-line male and female 3-pin XLR connectors. When this condition is detected, the 4-wire audio output channels are placed in their active (non-muted) state. Otherwise, they are off (muted) to maintain stable Model 545AR performance.

As previously described, a unit setting can disable the requirement that 18 volts DC or greater be present on pin 2 of the party-line XLR connectors for the active status LED to light and the 4-wire audio outputs to be active. This function is called the PL active detection function and disabling it can be appropriate for special applications. Refer to the Technical Notes section for details regarding this function and how it may be utilized.

Auto Null

The Model 545AR contains circuitry to automatically null the two 2-wire-to-4-wire interfaces. (2-wire is another term for a party-line circuit.) Normally this process is performed at the time of initial Model 545AR user set up and operation, but there's no reason why auto nulling can't be initiated anytime a user desires. The only time that auto null must be performed is if conditions have changed vis-à-vis the party-line intercom user devices, the wiring connected to a Model 545AR's party-line intercom interface connectors or, if connected, an external party-line intercom circuit. Even a small change to a party-line intercom circuit, such as adding or removing a section of cable, can be a sufficient change to require that the auto null process again be performed.

The auto null pushbutton switch, located on the unit's front panel, is used to activate the auto null process. To initiate auto null requires simply pressing and releasing ("tapping") the button. Two associated LEDs provide a visual indication of the auto null process, flashing when the auto null process for a specific channel is active. The sequence for both channels takes less than 15 seconds to complete.

The auto null function can only be enabled if the party-line interface is active. This requires, if the Model 545AR is selected to provide party-line power,

a current draw of approximately 5 milliamperes (mA) or more from pin 2 of either of the party-line interface connectors. If the unit is selected to interface with an external party-line circuit, approximately 18 volts DC or greater must be present on pin 2 of either of the party-line interface connectors. If neither of these conditions is met, the auto null function cannot be enabled. This will be indicated by the auto null LEDs flashing rapidly for a few seconds.

An auto null sequence begins with the muting of the 4-wire audio input and 4-wire output signal paths. This is followed by a short period of 24 kHz signal that is sent out both of the party-line intercom interface channels. This will turn off microphones on those connected user devices that are compatible with the RTS TW-series “mic kill” protocol. The actual auto nulling process is performed next. A series of tones will be sent out the party-line interface channels and the circuitry, under software control, will rapidly perform adjustments to achieve the best possible null (separation of send and receive audio). After the null adjustments have been made the results are stored in non-volatile memory. Once the nulling process is complete the 4-wire audio input and 4-wire audio output are again activated.

If possible, prior to performing an auto null it's polite to warn all personnel who are actively using the connected party-line intercom devices. The tones sent to the party-line intercom channels during the nulling process are not excessively loud or obnoxious, but most users might want to remove their headsets during the process. In addition to warning users, it might be a good time to ask them to mute any active microphones. While the automatic “mic kill” signal will apply to many user devices, it may not apply to all. Muting microphones is important as obtaining a “deep” null requires that no extraneous audio signals be present on the party-line circuit.

PL Active Detection Mode

A configurable feature allows a Model 545AR unit to operate from either of two operating modes. This is provided so that units can be used in both standard and non-standard applications. By default, the PL Active Detect function is enabled which is referred to as operating mode 1. This is appropriate in most applications. However, special situations can

benefit from using operating mode 2. Refer to the Technical Notes section for details on how to determine the Model 545AR's selected operating mode and how to change it.

Enabling PL Active Detection (operating mode 1) is appropriate for most applications and is considered the default. When a Model 545AR is selected for operating mode 1, full operation requires that current must be drawn from the party-line interface (when the Model 545AR is providing local (party-line) power) or a DC voltage must be present on pin 2 of the party-line interface connectors (when the Model unit is not providing local (party-line) power). The active LED on the front panel provides an indication that the unit is ready for full operation. If neither of these conditions is met, the two 4-wire audio outputs are muted, the auto null function can't be enabled, and the active status LED is not lit. Muting the 4-wire audio outputs ensures that unwanted audio is not sent to connected equipment. Preventing the auto null process from starting keeps an incorrect auto null from occurring. These operating requirements are desirable for most applications and will provide maximum performance.

Not all legitimate applications will meet these requirements and that's why the ability to disable the PL Active Detection function (operating mode 2) is provided. There will be situations where DC current will not be drawn from the Model 545AR's party-line interface. In other cases, no DC voltage will be provided to pin 2 of the party-line interface. With operating mode 2 the 4-wire audio outputs are always enabled and the auto null function can be used. No current draw from pin 2 or DC voltage on pin 2 of either of the party-line connectors is required for Model 545AR operation to take place.

A specific example when disabling the PL Active Detection function (mode 2) would be appropriate is when an application requires connecting the Model 545AR's party-line interface to a piece of equipment that requires DC voltage on pin 2 but doesn't draw current. Since this type of equipment (typically a wireless intercom base station) doesn't draw DC current the Model 545AR would not recognize this as a valid connection and normal operation would be prevented. Mode 2 would allow the unit to function; both 4-wire audio outputs would be active and the auto null function could be utilized.

Another example of where mode 2 would be useful is when a Model 545AR's party-line interface is connected to one or more Studio Technologies' Model 210 Announcer's Consoles which are being locally powered. (In this case, a Model 210 would be powered by way of a party-line intercom circuit, a powered IFB (talent cue) circuit, or an external source of 24 volts DC.) A Model 210 device being locally powered would be a completely "valid" connection to a Model 545AR. Selecting mode 2 would enable the 4-wire line-level outputs and allow auto null activation, even though no DC current is being drawn or DC voltage is being provided to the Model 545AR's party-line interface.

Level Meters

The four audio level meters on the Model 545AR's front panel are calibrated differently from typical "VU" meters. Their "steps" are labeled in reference to the level of signals being sent to, and received from, the party-line interface. The ballistics of the meters is also different, being a cross between VU and peak.

During operation, the green 0 LEDs will light in response to audio levels of -10 dBu being present on the two channels of the party-line intercom circuit. When a 0 LED lights it corresponds to +4 dBu being present on its associated 4-wire audio input or output connections.

The four green LEDs of each meter (-18, -12, -6, 0) indicate a level that is in the normal range. A yellow LED will light when a signal is approximately 6 dB or more above the party-line's -10 dBu nominal level. Optimal signals will result in the four green LEDs lighting almost solidly with the yellow LED lighting only on peak signals.

Technical Notes

PL Active Detection Modes

The Model 545AR allows its PL Active Detection operating mode to be configured. While this topic was previously discussed in the Operation section, additional information is provided in the following paragraphs.

To allow optimal performance in a variety of applications the Model 545AR can function in either of two PL Active Detection modes. The difference between the two modes is somewhat subtle, mainly relating to how the 4-wire audio output muting function responds to the status of the party-line interface's PL Active

Detection function which is related to the local power source's current or DC voltage detection function. It also impacts operation of the auto null function and the active status LED.

When the Model 545AR has been configured for operating mode 1, the PL Active Detection mode is enabled. This means that the two 4-wire audio outputs will remain muted unless a DC current of 5 mA or greater is actively being supplied by the local party-line interface (if the unit is set to provide party-line power). Requiring that a party-line device be connected (as evidenced by DC current being drawn) will minimize the chance that undesirable audio signals will be sent to the connected line-level audio equipment. These undesirable signals would typically consist of a portion of the audio input being "bounced" back through the Model 545AR's unterminated 2-wire-to-4-wire hybrid circuit. This condition is especially undesirable for optimal audio performance with 4-wire matrix intercom systems.

A similar scenario will take place for operating mode 1 if the Model 545AR's local power source has been set to not supply party-line power. If 18 volts DC or greater is not present on pin 2 of the party-line interface the 4-wire audio outputs will remain muted. In both cases whenever the 4-wire audio outputs are muted the auto null function can't be enabled and the Pin 2 Status LED will not light.

When the Model 545AR has been selected to disable the PL Active Detection function (operating mode 2), the two 4-wire audio outputs are always active and the auto null function can always be enabled. In operating mode 2 there is no requirement that a minimum amount of DC current be drawn from the party-line interface or that a DC voltage be present on pin 2 of the party-line interface connector. This mode is provided for atypical, but legitimate, applications where devices connected to the Model 545AR's party-line interface do not draw DC current or supply DC voltage.

A specific example when mode 2 would be appropriate would be the case where a Model 545AR is being used with a Telex® BTR-800 Wireless Intercom System. The BTR-800 is designed to directly interface with a 2-channel party-line (PL) intercom circuit. This circuit would typically have DC power and one or two audio channels associated with it.

(Each audio channel would typically have a terminating impedance of nominally 200 ohms.) The Model 545AR can provide such a PL circuit when the local power source is enabled. But a problem arises as the BTR-800 does not draw DC current from pin 2 of the connected PL circuit. It doesn't function in the same manner as would a typical PL intercom beltpack or standard user device. The BTR-800 doesn't use power from the PL connection, instead using its internal power source for operation. In this case, the Model 545AR's party-line interface would not be supplying current, the Active LED would not light, and the two 4-wire audio outputs would not be enabled. Users of the BTR-800 would receive 4-wire audio from the Model 545AR but the PL audio would not be sent audio out the Model 545AR's two 4-wire output channels. Turning off the PL Active Detection function would resolve this issue. Even though no DC current would be supplied by the Model 545AR's PL interface, the 4-wire audio outputs would be enabled and successful PL interface operation would take place.

Viewing and Changing the PL Active Detection Mode

A Model 545AR's PL Active Detection mode can be viewed and, if desired, changed by way of a power-up/button-press sequence. With the Model 545AR in the un-powered state (no source of nominal 12 volts DC applied), press and hold the auto null pushbutton. Then apply power while continuing to press the auto null button. The unit will go through its normal power-up sequence and upon completion light one of the auto null LEDs. If the Model 545AR is configured to have the PL Active Detection function enabled (mode 1), the auto null CH 2 LED will light. If the unit is configured for disabling the PL Active Detection (mode 2), the auto null CH 1 LED will light. From the factory the Model 545AR will typically be configured for operating mode 1.

If the auto null button is released within a few seconds of the one of the auto null LEDs displaying the active mode no change will be made and the Model 545AR will begin normal operation. However, if after the operating mode is displayed the auto null button remains pressed for approximately five additional seconds the mode will automatically change ("toggle"). For example, if the auto null

CH 2 LED lights and indicates that operating mode 1 is the current configuration, continuing to hold the auto null button will cause the configuration to change to operating mode 2. It should be very clear that a change has occurred as the auto null CH 1 will stop lighting and the auto null CH 2 LED will become lit. After the change has occurred, releasing the button will cause the revised configuration to be saved and the Model 545AR will begin operation under the newly selected mode. When described in words this procedure seems fairly technical, but a couple of practice sessions will show how simple it actually is.

Maintaining Correct Input Signal Levels

The Model 545AR's 4-wire audio inputs and outputs are designed for compatibility with the ubiquitous +4 dBu audio level standard. Applying signals to the 4-wire audio inputs at a significantly lower level than the intended nominal will reduce the signal-to-noise ratio (raising the perceived noise floor) and can prevent the connected party-line devices from operating optimally. Applying signal levels to the 4-wire inputs significantly higher than nominal will reduce the headroom and greatly increase the chance of reaching audio "clipping." Obviously, these cautions are not unique to the Model 545AR, but apply to most analog audio equipment. The front-panel level meters provide an easy means of confirming that a Model 545AR is being presented with the correct audio levels.

To confirm correct party-line intercom operation at locations away from where the Model 545AR is installed, it's possible to use the Model 72 Level Meter/Interface, also available from Studio Technologies. The Model 72 is a compact, portable device that plugs directly into a party-line intercom or IFB circuit and provides two useful functions. Two 5-segment LED meters display the audio levels present on pins 2 and 3. Two "dry" line-level audio outputs are also provided, one for each channel. Complete information on the Model 72 is available on the Studio Technologies' website. The NTI Instruments MR Pro handheld audio measurement device is also an excellent means of confirming party-line performance. It's a unique device in that it will simultaneously display audio signal levels and DC power present on a 3-pin XLR connector.

Party-Line Interface Current Draw

The Model 545AR's local party-line power supply circuit is designed to provide up to 300 milliamperes of DC current. By design, the internal power supply circuit is protected so that an overload condition, or even a complete short circuit, should not cause damage. Exceeding 300 mA for more than one second will cause the auto shut-down mode to become active. A continuous overload condition will cause the internal power supply to cycle through a 4-seconds-on\5-seconds-off sequence. Restoring the output load to be within the rated 300 mA will allow the internal power supply output to again operate normally. In extreme cases, such as when the Model 545AR is located in an environment with elevated temperatures, a few minutes may be required from the time an overload condition is removed to when normal operation will again take place. Please don't test the Model 545AR's ability to sustain frequent overload or short-circuit conditions! The long-term reliability of the unit can be impacted by the stresses caused by these fault conditions.

The active LED makes it easy to know if an excessive load, or a short circuit, is being placed on the internal power supply output. Technically the LED, under software control, provides a direct indication of the party-line's DC voltage. When the internal party-line power supply is active, the output voltage is directly related to the amount of current being drawn.

The LED will light steadily when the internal power supply's DC output voltage is within its normal range. During normal operation the DC level on pin 2 of the party-line XLR connector will be approximately 28 volts. The LED will begin to flash on and off if the level falls below approximately 24 volts for at least one second. This will typically occur because the current draw is greater than nominally 300 mA maximum.

There's really only one piece of advice when it comes to understanding how to use the active status LED when the local (internal) power supply is enabled: if the LED flashes there's a problem that must be corrected! The most likely cause would be too many user devices being connected to the party-line output connectors. It's also possible that a wiring problem could cause a partial or full short circuit between the output XLRs' pin 1 (common) and pin 2 (power with channel one audio) pins. Troubleshooting should prove quick

and easy. Begin by disconnecting the party-line user devices while leaving the cabling connected. Observe the active status LED and see if the problem has gone away. If the problem is no longer present, check the user device(s) to see which one is causing the fault. If the problem has not gone away, review the interconnecting cables and find the cause of the fault condition. Within five seconds of the problem being "cleared" the active status LED will stop flashing.

Cable Length

There are no "hard and fast" rules defining the maximum possible cable length when connecting and powering user devices with the Model 545AR's party-line interface. The maximum cable length is directly related to the amount of resistance in the interconnecting cable; the lower the resistance per foot (or meter) of cable, the longer the cable can be. Although cable capacitance affects high-frequency performance, resistance is the limiting factor in most cases. For example, a contemporary microphone cable is Belden 1172A which has 18 ohms of resistance per conductor per 1000 feet. Since we're using two conductors to carry the DC power (pins 1 and 2) you'd get 36 ohms per 1000 feet of cable. By knowing the cable resistance value, along with the minimum voltage and maximum load current required by a party-line user device, a simple "ohms law" calculation will tell you the maximum cable length.

Let's use the example of an RTS BP-325 beltpack being connected to the Model 545AR's party-line XLR connector. We'll select Belden 1172A as the interconnecting cable. For correct operation, a BP-325 needs at least 18 volts DC between pins 1 and 2 of its interface connector. The BP-325 has a rated maximum current draw of approximately 65 mA. The Model 545AR presents a party-line voltage of 28 volts across pins 1 and 2 and can supply a maximum current of 300 mA. (As the BP-325's current draw is well within the Model 545AR's capability, this is not a limiting factor.) The difference between the voltage supplied by the Model 545AR (28 volts) and the voltage required by the BP-325 (18 volts) allows a 10 volts maximum drop over the interconnecting cable. Using the BP-325's current draw and the maximum voltage drop, the maximum cable resistance can easily be calculated: 10 volts divided by 0.060 amperes equals 167 ohms. Finally, with the Belden 1172A's 36 ohms (total) per 1000 feet of cable, a maximum of approximately 4600 feet (1424 meters)

of cable can be used and still be less than or equal to 167 ohms. (Of course, this is for only supporting one BP-325.) Following this example as a guide, entering the appropriate values will allow you to determine the maximum cable length for your application.

Cabling Issues – Crosstalk

The Model 545AR’s party-line interface conforms to the broadcast-industry standard for sending DC power and two channels of audio over a single pair-with-shield audio cable. This implementation allows standard portable cables, such as those used with microphones, to interconnect various party-line user devices. This method is undoubtedly convenient and practical, but is not without limitations. The main audio quality issue is the possibility of crosstalk between the two audio channels. This issue arises due to the capacitance presented by the two wires that form the twisted pair. The greater the capacitance presented and the longer the cable run, the greater the crosstalk. Is this normally a problem during actual use? No. But it’s something that should be noted.

Software Version Display

After the Model 545AR’s power-up sequence has completed, LEDs in two of the unit’s level meters are used to automatically display the software version number. This is useful when working with factory personnel on

application support and troubleshooting situations. The five LEDs associated with the CHANNEL 2 TO column of LEDs are used to display the major version number with a range of 1 through 5. The five LEDs associated with the CHANNEL 2 FROM column are used to display the version’s sub-number which ranges from 0 to 5. (No CHANNEL 2 FROM LEDs lit indicates a sub-number of 0.) The software version number will display for approximately one second after the power-up sequence has completed but before normal operation begins. Refer to Figure 2 for a detailed view of the LEDs and the corresponding software version numbering scheme.

Note that while it’s easy to determine which software version is loaded into the Model 545AR, a trip back to the factory is required to update it. The 8-bit micro-controller that provides the unit’s logic “horsepower” also includes internal FLASH memory. This non-volatile memory is used to store the operating software (“firmware”). Re-programming this memory requires using a specialized programming unit. The programmer uses a ribbon cable and connector to interface with the Model 545AR’s main printed circuit board. As you would guess, once connected, reprogramming takes only a matter of seconds. Unfortunately, the programmer is not something that would be found in a typical “field shop” or repair facility.

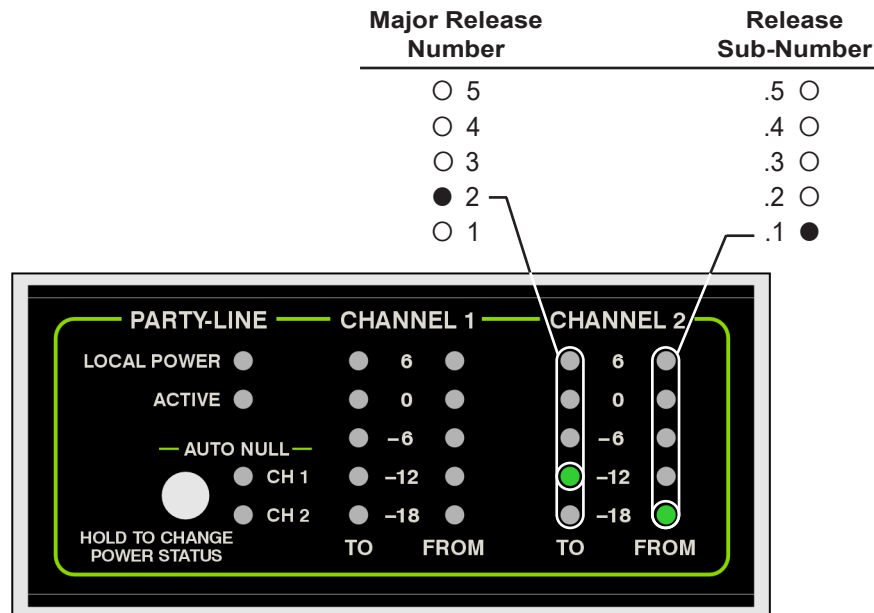

Figure 2. Detail of front panel showing the status LEDs that display the software version. In this example, the software version is 2.1.

Two Units can be a TW-12B Replacement

Two Model 545AR units with their 4-wire interface connectors linked in a crossover fashion can act as a universal 2-wire-to-2-wire “bridge.” This should, in theory, create an updated and improved version of the venerable Clear-Com TW-12B unit. In this arrangement, two independent 2-wire party-line intercom systems can function as one while still maintaining full electrical isolation.

The connection scheme is very simple, using just four male-female 3-pin XLR patch cords. The 4-wire outputs of the first Model 545AR would be connected to the 4-wire inputs on the second Model 545AR; the 4-wire outputs on the second Model 545AR would connect to the 4-wire inputs on the first Model 545AR. A 2-wire party-line intercom circuit would connect to each Model 545AR unit. Power can be provided by the connected intercom circuits or by way of an external source of 24 volts DC. The final step to achieve correct performance is for the auto null function on each Model 545AR to be activated. Refer to Figure 3 for details.

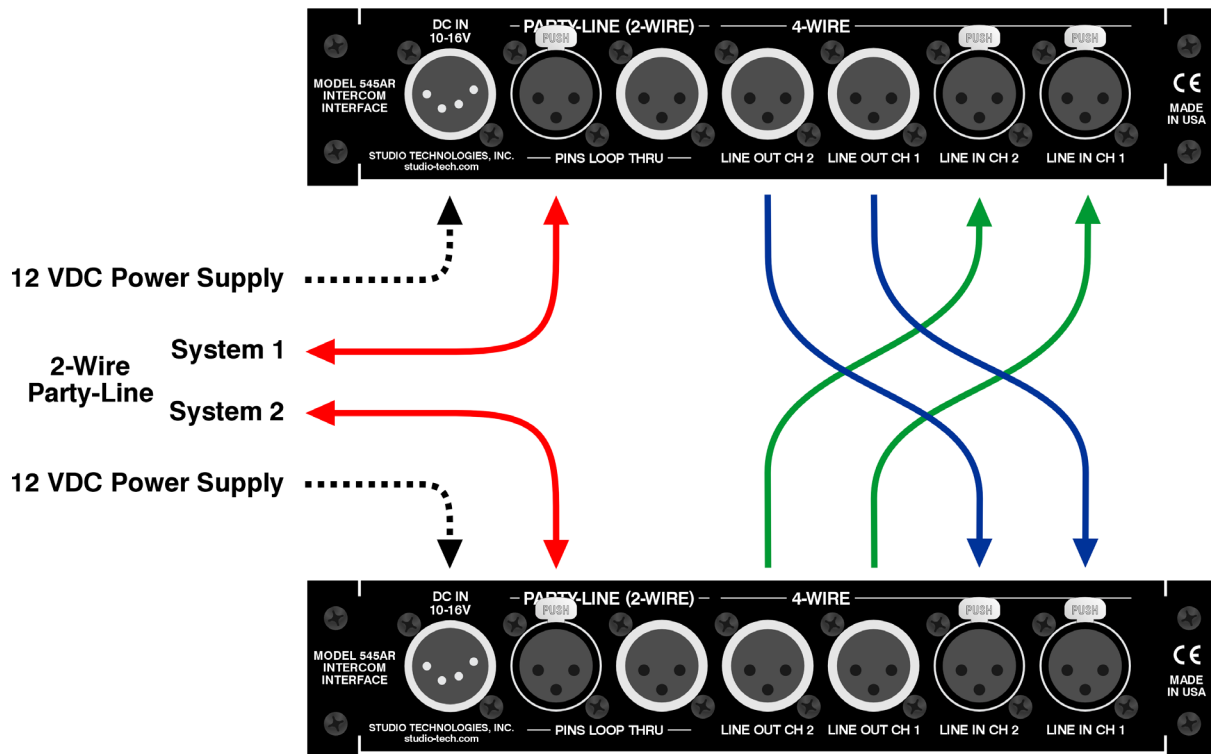

Figure 3. Two Model 545AR units connected as a universal 2-wire-to-2-wire bridge

Specifications

Power Requirement:

10 to 16 volts DC, 1.2 A max at 12 volts DC, Studio Technologies' PS-DC-02 (100-240 V, 50/60 Hz, input; 12 volts DC, 1.5 A, output) included with each unit

General Audio:

Frequency Response: -0.3 dB @ 100 Hz (-4.8 dB @ 20 Hz), -2 dB @ 8 kHz (-2.6 dB @ 10 kHz)

Distortion (THD+N) – 4-Wire Input to PL Interface Pin 2: <0.15%, measured at 1 kHz

Distortion (THD+N) – 4-Wire Input to PL Interface Pin 3: <0.15%, measured at 1 kHz

Signal-to-Noise Ratio – 4-Wire Input to PL Interface Pin 2: >65 dB, A-weighted, measured at 1 kHz

Signal-to-Noise Ratio – 4-Wire Input to PL Interface Pin 3: >73 dB, A-weighted, measured at 1 kHz

Party-Line (PL) Intercom Interface:

Type: 2-channel analog PL, unbalanced (pin 1 common; pin 2 DC with channel 1 audio; pin 3 channel 2 audio)

Compatibility: 2-channel PL intercom systems such as those offered by RTS®

Power Source: 28 volts DC, 300 mA maximum, on XLR pin 2

Impedance – Local PL Power Not Enabled: >10 k ohms

Impedance – Local PL Power Enabled: 200 ohms

Analog Audio Level Pin 2: -10 dBu, nominal, +3 dBu maximum

Analog Audio Level Pin 3: -10 dBu, nominal, +7 dBu maximum

Mic Kill Signal Support: 24 kHz, ±1%, square-wave

Party-Line (PL) Hybrids: 2

Topology: 3-section analog circuitry compensates for resistive, inductive, and capacitive PL loads

Nulling Method: automatic upon user initiation, processor implements digital control of analog circuitry; settings stored in non-volatile memory

Nulling Line Impedance Range: 120 to 350 ohms

Nulling Cable Length Range: 0 to 3500 feet, typical

Trans-Hybrid Loss – PL Interface Pin 2: >50 dB, typical at 800 Hz

Trans-Hybrid Loss – PL Interface Pin 3: >55 dB, typical at 800 Hz

4-Wire Inputs: 2

Type: transformer-coupled, capacitor isolated

Impedance: 13 k ohms

Nominal Level: +4 dBu

Maximum Level: +22 dBu

4-Wire Outputs: 2

Type: transformer-coupled, capacitor isolated

Impedance: 50 ohms nominal

Nominal Level: +4 dBu

Maximum Level: +20 dBu into 2 k ohms

Meters: 4

Function: displays level of 4-wire audio input and output channels

Type: 5-segment LED, modified VU ballistics

Connectors:

Party-Line (PL or 2-Wire) Interface: 1, 3-pin male XLR and 1, 3-pin female XLR

4-Wire (Line) Inputs: 2, 3-pin female XLR

4-Wire (Line) Outputs: 2, 3-pin male XLR

Power (DC) Input: 4-pin male XLR

Environmental:

Operating Temperature: 0 to 50 degrees C (32 to 122 degrees F)

Storage Temperature: -40 to 70 degrees C (-40 to 158 degrees F)

Humidity: 5 to 95%, non-condensing

Altitude: not characterized

Dimensions – Overall:

8.70 inches wide (22.1 cm)

1.72 inches high (4.4 cm)

8.30 inches deep (21.1 cm)

Weight: 1.7 pounds (0.77 kg); rack-mounting installation kits add approximately 0.2 pounds (0.09 kg)

Deployment: intended for tabletop applications.

Four optional mounting kits are also available:

RMBK-10 allows one unit to be mounted in a panel cutout or on a flat surface

RMBK-11 allows one unit to be mounted in the left- or right-side of one space (1U) of a standard 19-inch rack

RMBK-12 allows two units to be mounted in one space (1U) of a standard 19-inch rack

RMBK-13 allows one unit to be mounted in the center of one space (1U) of a standard 19-inch rack

Specifications and information contained in this User Guide subject to change without notice.

Model 545AR
INTERCOM INTERFACE

Appendix A—Interfacing RTS® Matrix Intercom Systems and RVON-I/O with the Model 545AR Intercom Interface

ADAM™ Matrix Intercom System Analog Ports to Model 545AR Intercom Interface

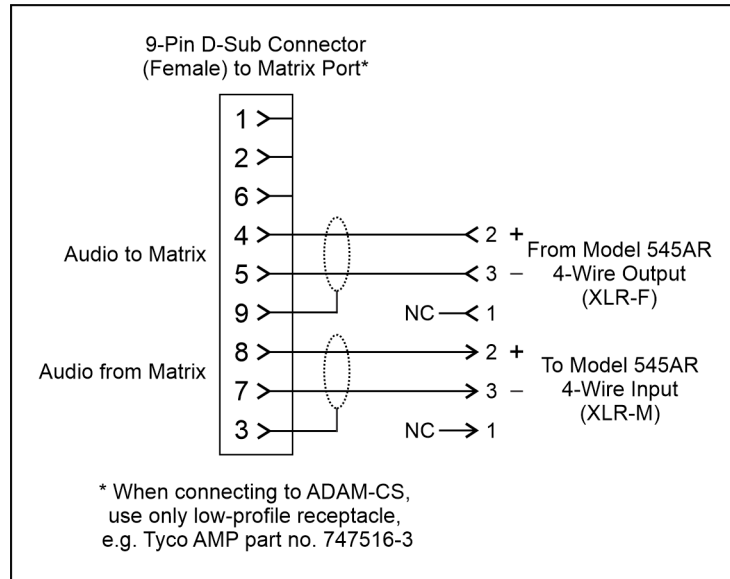

RVON-I/O I/O Connections to Model 545AR Intercom Interface

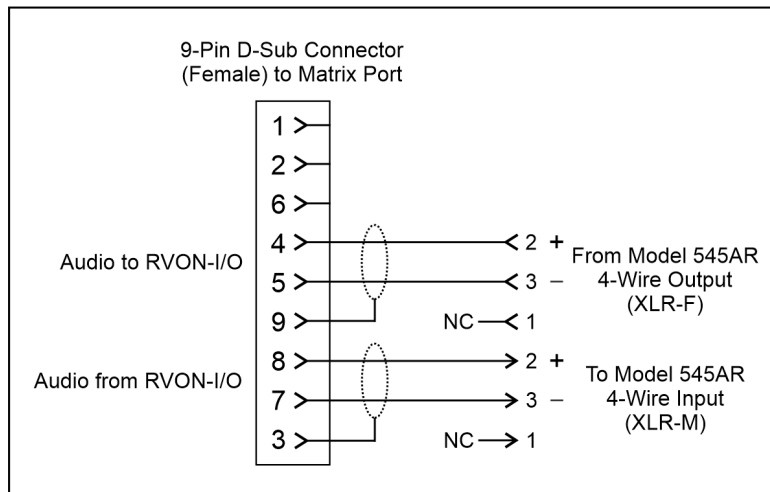

Appendix B—Interfacing Riedel® Artist™ Matrix Intercom System Analog Ports with the Model 545AR Intercom Interface

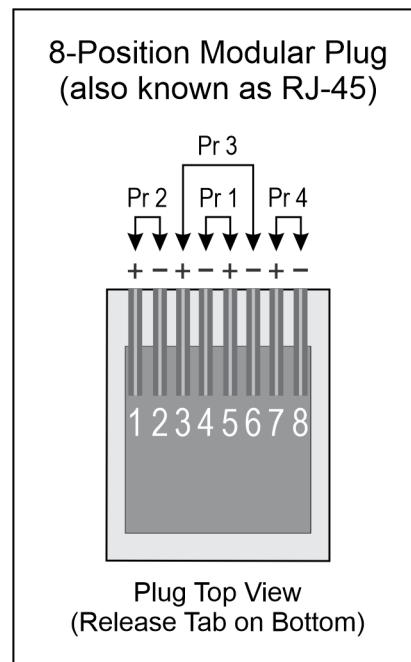
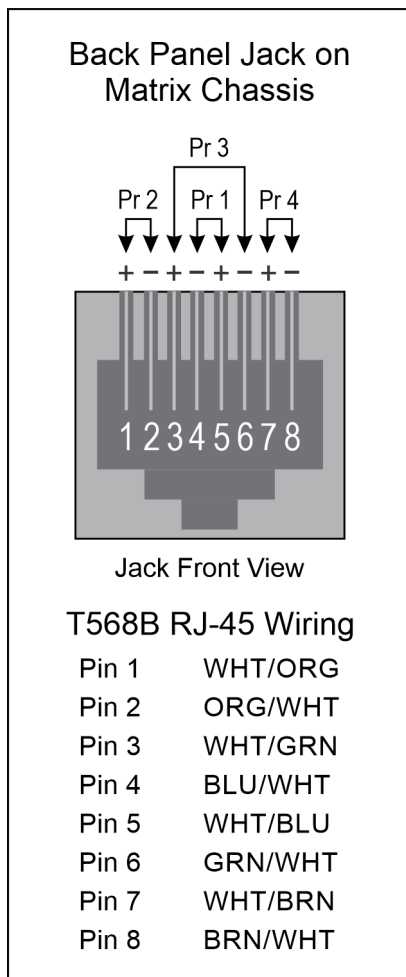
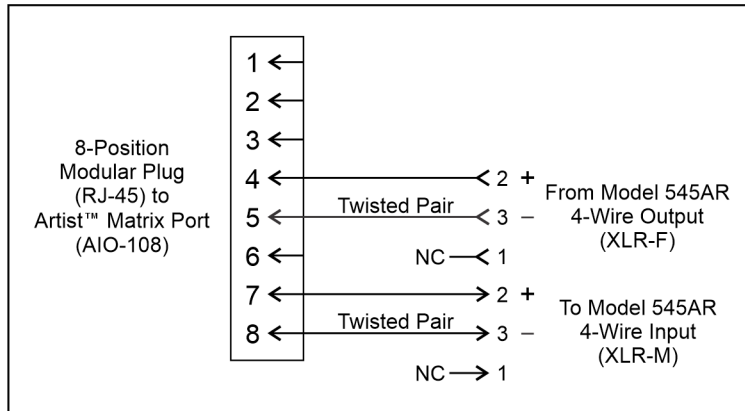

Model 545AR
INTERCOM INTERFACE

Appendix C—Interfacing Clear-Com® Matrix Intercom System Analog Ports with the Model 545AR Intercom Interface

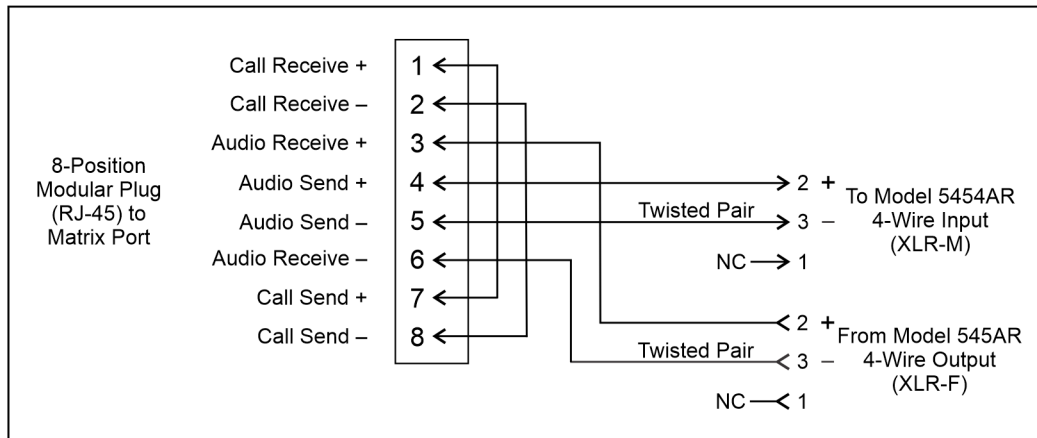

Model 545AR
INTERCOM INTERFACE

**Appendix D—Graphical Description of the Installation Kit for
Panel Cutout or Surface-Mounting Use (Order Code: *RMBK-10*)**

This installation kit is used for mounting one Model 545AR unit into a panel cutout or flat surface.

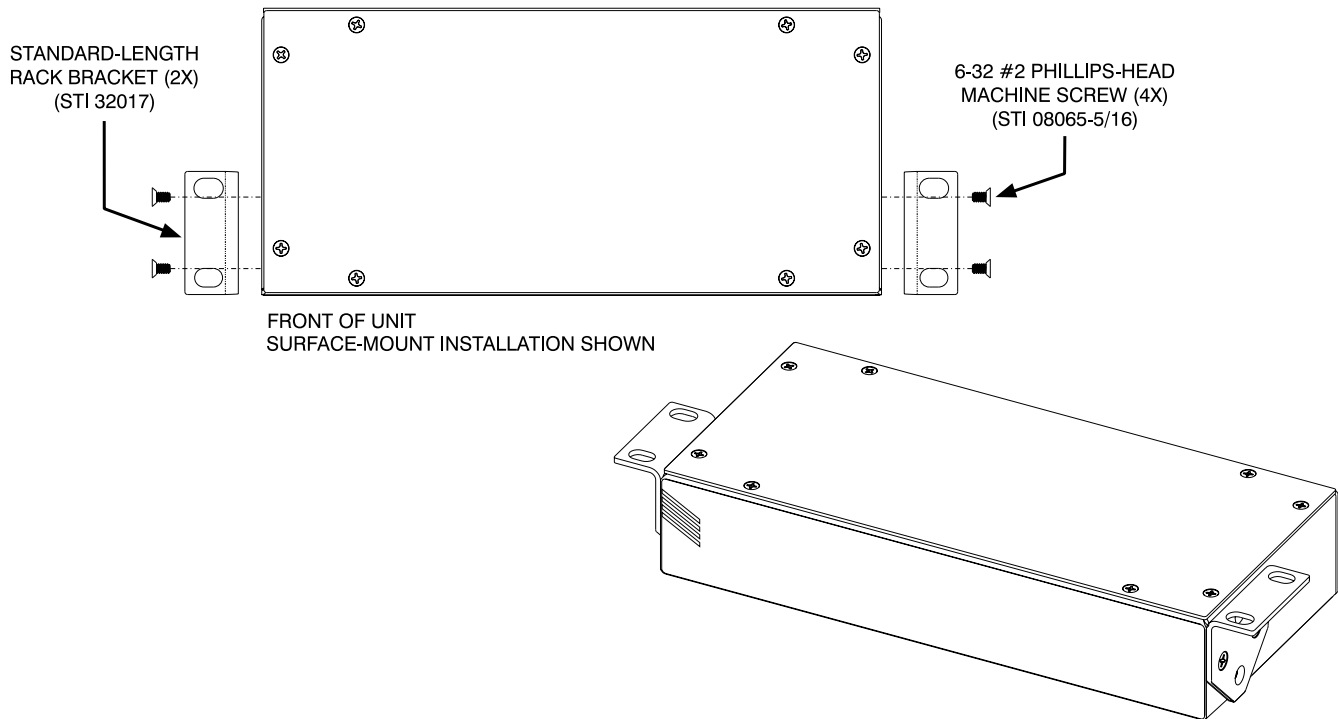
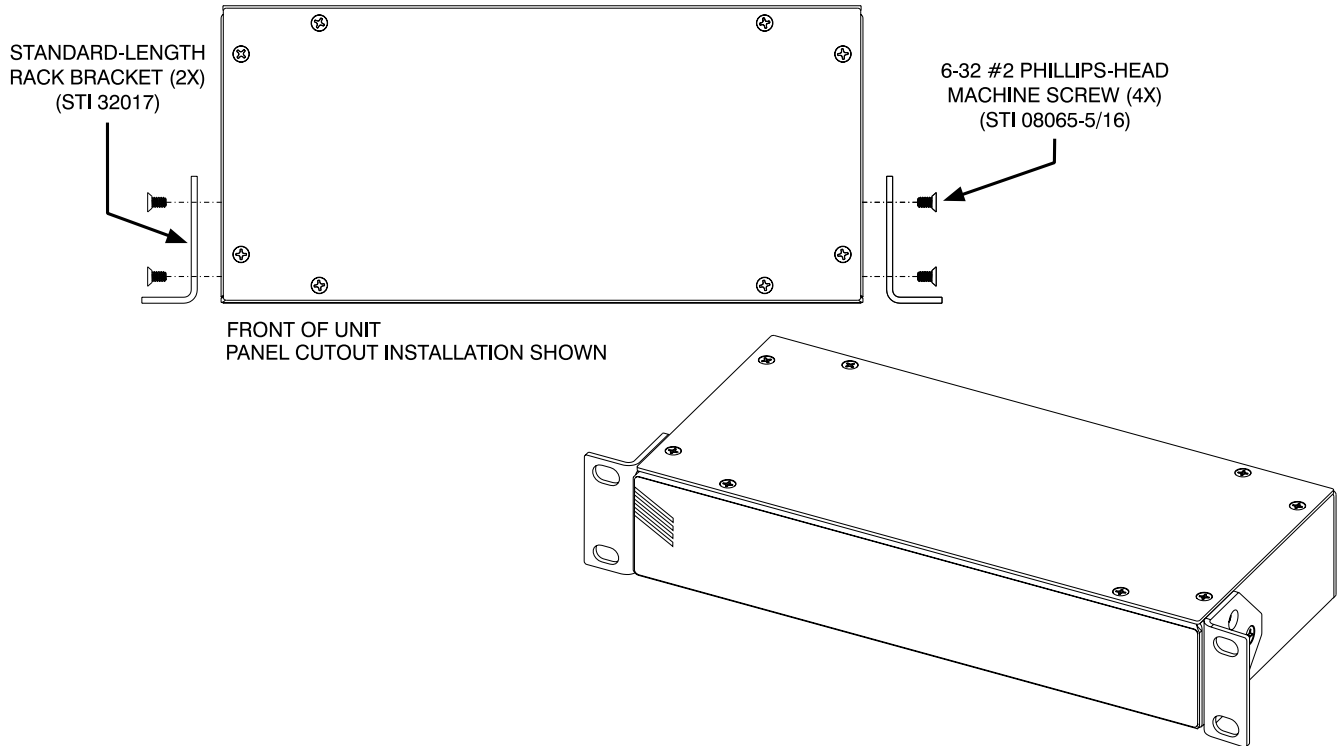

Model 545AR
INTERCOM INTERFACE

Appendix E—Graphical Description of Left- or Right-Side Rack-Mount Installation Kit for One “1/2-Rack” Unit (Order Code: *RMBK-11*)

This installation kit is used for mounting one Model 545AR unit into one space (1U) of a 19-inch equipment rack. Unit will be located on the left- or right-side of the 1U opening.

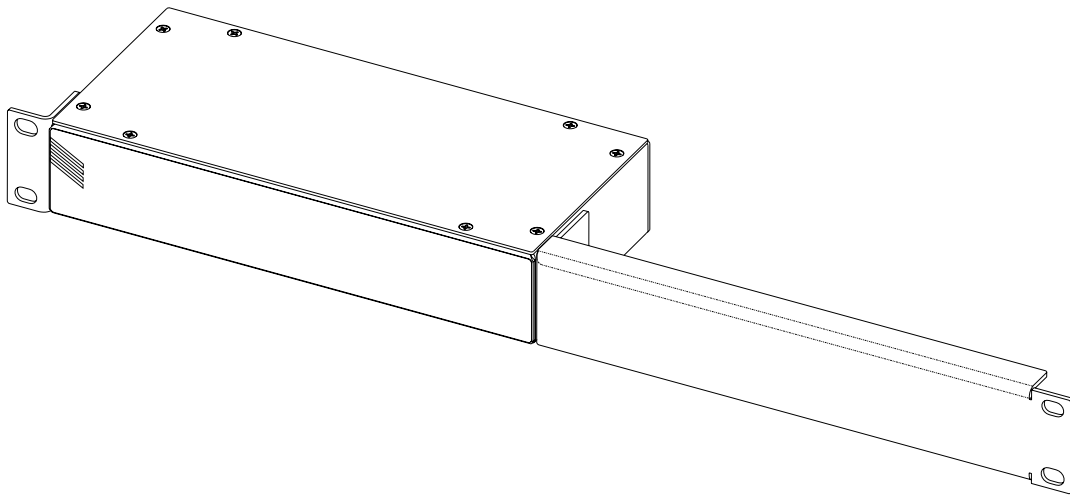
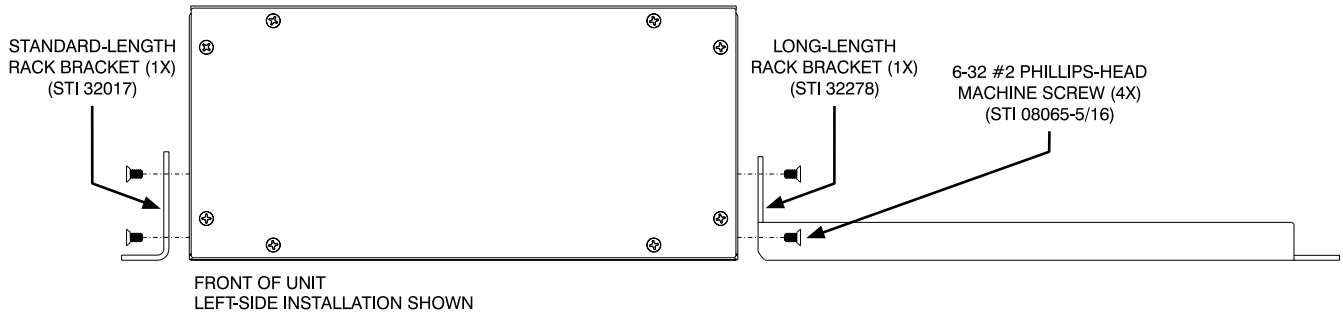

Model 545AR
INTERCOM INTERFACE

Appendix F—Graphical Description of Rack-Mount Installation Kit for Two “1/2-Rack” Units (Order Code: *RMBK-12*)

This installation kit can be used to mount two Model 545AR units or one Model 545AR unit and another product that is compatible with the RMBK-12 (such as the Studio Technologies’ Model 5421 Dante Intercom Audio Engine) into one space (1U) of a 19-inch equipment rack.

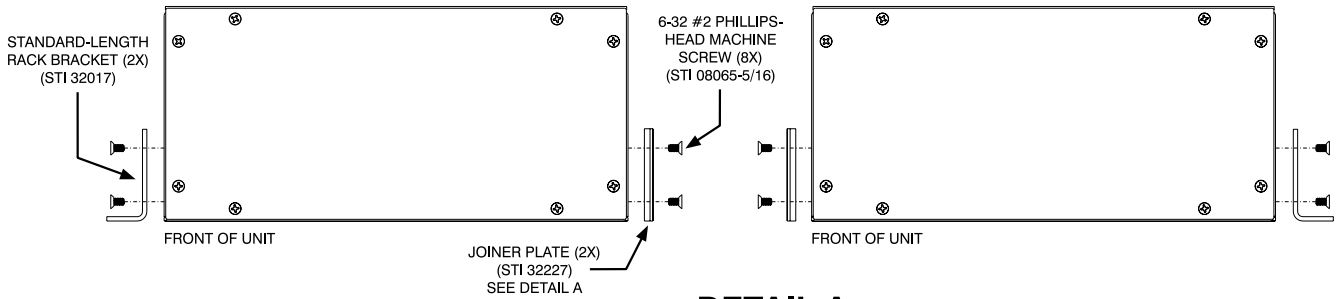

DETAIL A

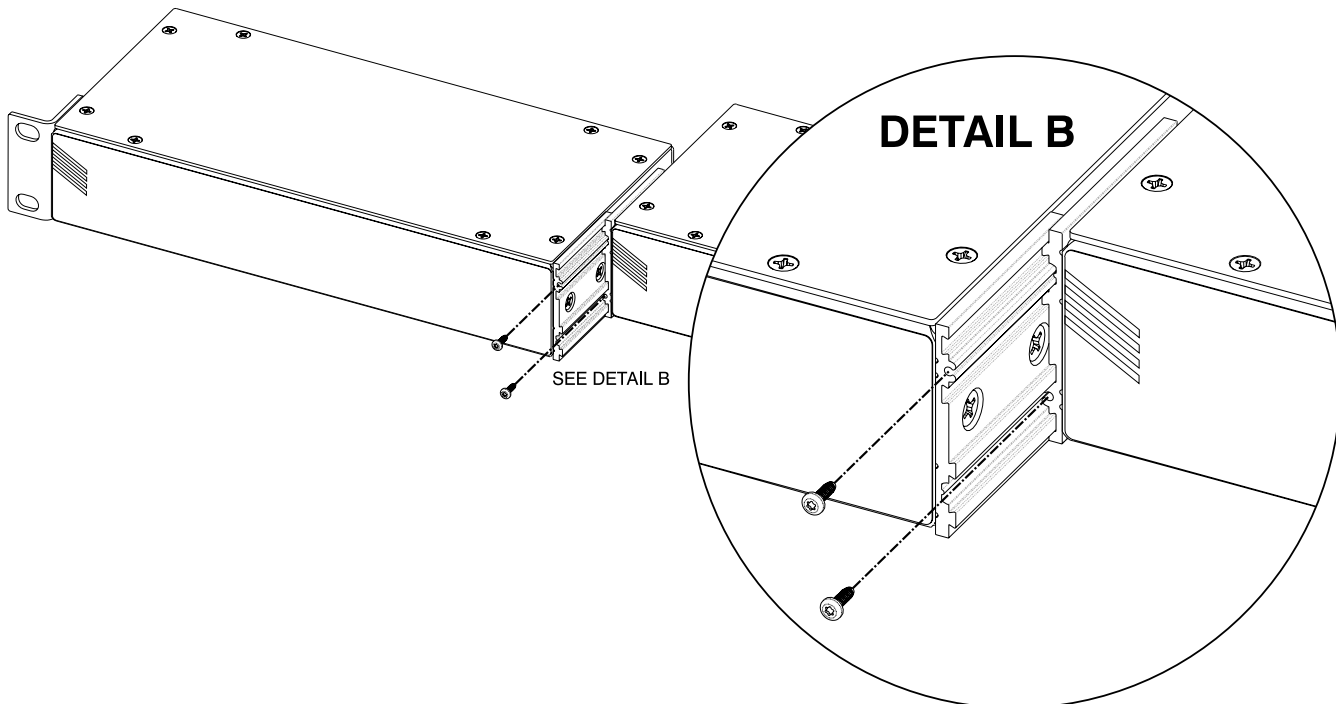
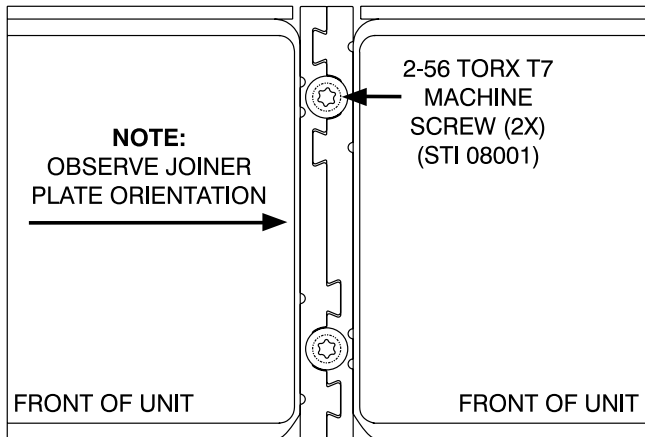

Appendix G—Graphical Description of Center Rack-Mount Installation Kit for One “1/2-Rack” Unit (Order Code: *RMBK-13*)

This installation kit is used for mounting one Model 544AR unit into one space (1U) of a 19-inch equipment rack. Unit will be located in the center of the 1U opening.

