



Model 2 Central Controller and Related Components

User Guide

This User Guide is applicable for Model 2 serial numbers:
M2-00151 and later

Issue 7, November 2001

© 2001 by Studio Technologies, Inc., all rights reserved

5520 West Touhy Avenue
Skokie, Illinois 60077 U.S.A.
Telephone (847) 676-9177
Fax (847) 982-0747
www.studio-tech.com
support@studio-tech.com

This page intentionally left blank.

Table of Contents

| | |
|---|----|
| Foreword | 5 |
| Introduction | 7 |
| What This User Guide Covers..... | 7 |
| Model 2 Central Controller | 8 |
| Model 22 Access Station | 11 |
| Model 32 & Model 33 Talent Amplifiers | 11 |
| Installation | 12 |
| Locating the Unit | 12 |
| Mounting | 13 |
| Program Inputs..... | 13 |
| Auxiliary Audio Input | 13 |
| Talent Amplifier Output | 14 |
| Line Outputs | 14 |
| Connecting Telephone Lines | 15 |
| Access Stations | 16 |
| Monitor Output | 18 |
| Connecting AC Mains Power | 18 |
| Operation | 19 |
| The Model 2's Front-Panel Controls and Indicators | 19 |
| It's Time to Use the System! | 22 |
| Technical Notes | 23 |
| Circuit Descriptions | 29 |
| Model 2 Central Controller | 29 |
| Model 22 Access Station | 38 |
| Model 32 Talent Amplifier | 40 |
| Model 33 Talent Amplifier | 41 |
| Troubleshooting | 42 |
| Model 2 Central Controller | 42 |
| Model 22, Model 32, & Model 33 | 43 |
| Specifications | 45 |

Figure 1 — Model 2 Rear Bracket Mounting Hole Location Diagram

Figure 2 — Model 25A 19-Inch Rack Adapter Diagram

Figure 3 — Model 28A Panel Adapter Diagram

Figure 4 — Model 22 Access Station Diagram

Block Diagrams

Model 2 Central Controller

Model 22 Access Station

Model 32 Talent Amplifier

Model 33 Talent Amplifier

This page intentionally left blank.

Foreword

Many people contributed to the creation of the Model 2 and related items. In general, a good time was had by all—with lots of takeout Chinese food eaten in the process! Jim Cunningham designed most of the analog circuitry. Mitch Budniak did the logic and power supply work. Al Lux designed the printed circuit boards. Carrie Loving provided engineering support and kept track of numerous design changes. Fred Roeck designed the mechanicals and lobbied hard for the color green on the front panel. Joe Urbanczyk implemented the computerized testing procedures on our Audio Precision System One.

Studio Technologies is receptive to your comments and questions. Please contact me with your questions, comments, and suggestions. I can be reached by voice at (847) 676-9177, fax at (847) 982-0747, or via the Internet @ www.studio-tech.com.

Sincerely,

Gordon K. Kapes
President

This page intentionally left blank.

Introduction

The IFB Plus Series Model 2 Central Controller from Studio Technologies is a highly integrated, two-channel IFB (interrupted foldback or interrupted feedback) system contained in a single rack space unit. It is expressly designed to provide talent cueing for ENG, SNG, and mobile production facilities. The performance and features of the Model 2 reflect the needs of contemporary applications. Only after extensive polling of field production and engineering personnel was the Model 2's feature group established. We think you'll find the Model 2 a great addition to your facility.

What This User Guide Covers

This User Guide applies to Studio Technologies, Inc. IFB Plus Series Model 2 Central Controllers with a serial number of M2-00151 and later. If you are installing a Model 2 with a serial number of M2-00122 or earlier, please contact Studio Technologies to obtain the appropriate documentation.

This guide is designed to assist you when installing, configuring, and using the Model 2 Central Controller. It also contains detailed service information and block diagrams. A separate packet, provided with the User Guide, contains the schematic diagrams.

The following items will be covered in this User Guide:

Model 2 Central Controller

An integrated two-channel IFB unit intended for applications where space is at a premium, yet high performance is still required. The unit contains everything

required to implement a full-featured system in a single rack space. Includes multiple program inputs, integral telephone interfaces, monitor amplifier, internal interrupt microphone, among many other features. The unit is powered by 120 or 220/240V, 50/60Hz.

Model 22 Access Station

Used by a producer or director to access the Model 2's IFB channels. Allows connection of a Studio Technologies Model 11A gooseneck microphone or a line-level audio source. Contains two lighted push button switches which display IFB interrupt status. Up to four Model 22s can be connected to and powered by a Model 2 Central Controller. The Model 25A 19-inch Rack Adapter allows a Model 22 Access Station and Model 11A gooseneck microphone to be mounted in a single 19-inch rack space. The Model 28A Panel Adapter allows a Model 22 and Model 11A gooseneck microphone to be installed in an opening made in a table, equipment console, etc.

Model 32 & Model 33 Talent Amplifiers

The Model 32 and Model 33 Talent Amplifiers are self-contained "belt pack" units that drive talent ear pieces or headsets. Up to four Model 32 and/or Model 33 Talent Amplifiers can be connected to, and powered by, a single Model 2 Central Controller.

The Model 32 is intended for use by on-air personnel, and contains a source switch, along with an output level control. Either IFB channel 1 or IFB channel 2 can be sent to the talent, along with the desired audio "volume."

The Model 33 is unique in that a "mix" of IFB channels 1 and 2 can be created. Two

level controls, along with a source select switch, allows camera and production personnel to hear IFB cues from either or both channels. This allows IFB signals intended for both technician and talent to be simultaneously monitored.

Model 2 Central Controller

Contained in a single rack space unit is everything required to implement a two-channel IFB system. Features include multiple program inputs, telephone interfaces, voice-operated (VOX) interrupt, level meters, monitor amplifier, and internal interrupt microphone. Up to four Model 22 Access Stations can be connected to the Model 2, allowing producer or director positions to access the IFB channels. In addition, up to four Model 32 or Model 33 Talent Amplifiers can be connected to a Model 2. The Model 32 and 33 allow personnel access to the IFB channels using a single standard microphone cable.

The Model 2 packs numerous features into a single, 19-inch rack space. Standard connectors are used throughout, including 3-pin XLR-type, 1/4-inch 2-conductor, 9-position D-subminiature, and modular telephone (RJ11-type) jacks. Power is supplied by standard 120 or 220/240V (factory configured), 50/60Hz via a detachable cord.

IFB Channels

The Model 2 contains two independent IFB channels. Each channel has individual controls and indicators, including program source select switches, program level control, 5-segment LED level meter, and LED status indicators. We'll describe one channel in this paragraph. Six switches allow the four program inputs and incom-

ing audio from the two telephone interfaces to be selected as program audio. A level control allows adjustment of the program audio level relative to the fixed interrupt audio level. A 5-segment LED level meter displays the composite IFB channel audio level, i.e., program and interrupt audio level. The meter facilitates the rapid setting of the program level control, as well as providing a general indication of the channel's signal level.

Each channel's composite IFB audio signal (program and interrupt audio) is sent to four places: line output, talent amplifier output, telephone interface 2, and monitor amplifier. The line outputs provide electronically balanced, line-level signals that interface with external equipment via two XLR-type connectors. The talent amplifier output provides channel 1 and 2 audio, along with +18Vdc power on one 3-pin XLR-type connector. Any combination of up to four Model 32 or 33s can be connected to the talent amplifier output.

Program Inputs

The Model 2 contains four program inputs. Each can be individually assigned to the two IFB channels, with the ability to assign multiple program inputs to an IFB channel. Program signals enter the unit via four XLR-type connectors on the back panel. The program inputs are electronically balanced with a nominal input impedance of 24k ohms. They feature low noise, low distortion, and high common mode signal rejection. Each program input has a trim potentiometer associated with it. The trim pots, accessible from the back panel, allow the nominal +4dBu input level to be adjusted over a ± 8 dB range.

Program audio is muted whenever an interrupt takes place. A sophisticated analog switch is used to give a noise-free mute with absolutely no clicks or pops! If desired, a program “dim,” rather than a full mute can be implemented by adding two resistors to the Model 2’s circuit board.

Compressor/Limiters

Each IFB channel contains a studio-quality compressor/limiter. The compressing function evens out variations in the interrupt audio signals. The limiting function smoothly controls peak signal levels. Together, they make talent cues more intelligible and prevent abnormally high signal levels from reaching a user’s ears. The resulting audio quality is very, very good.

Signal Routing

In the standard configuration, only interrupt audio is routed through the compressor/limiter before it is sent to the talent amplifier output, line output, telephone interface 2, etc. Program audio is routed, via the program audio level control and mute/dim circuit, directly to the talent amplifier output, line output, etc. Thus the dynamic range of the program signal is not altered. Some installations may benefit from the program audio being routed through the compressor/limiters. This “leveling” action can improve intelligibility of the program audio, especially in areas of high ambient noise such as news remotes or sporting events. Resistor positions on the Model 2’s circuit board allow a technician to change the audio flow, routing program audio via the compressor/limiters. The only downside is that this rerouting greatly limits the ability to adjust the relative level of the program audio versus the interrupt audio. This is

because the compressor/limiter function reduces the dynamic range of the program audio. As the program level control is turned “up,” the compressor acts to reduce the signal level! Also, some users may find the compressed program signal more fatiguing due to the higher average audio level.

Telephone Interfaces

The Model 2 contains two telephone interfaces. Both interfaces can be used to bring audio into the Model 2 from the outside world. These two audio signals can be independently assigned as program sources for IFB channels 1 and 2, as well as being used as an input source for the voice operated (VOX) interrupt function. Each telephone interface has a receive level trim potentiometer that is accessible via access holes in the front panel. The large variations one finds in telephone line signal levels make “on the fly” level trimming a useful feature. In addition to receiving audio, telephone interface 2 can be used to originate an IFB feed. A switch selects if audio will be received from the outside world, or if audio from IFB channel 1 or 2 will be sent out the interface.

The two telephone interfaces contain a unique feature which allows two very different types of telephone “lines” to be correctly interfaced. Each interface can be independently set to operate in either the telephone-line mode or the standard-audio mode. A telephone line has the profile of being a 2-wire, DC-biased (normally –48Vdc) circuit provided by a local telephone company. A standard audio signal could be provided by, for example, a fax adapter associated with a cellular telephone.

When an interface is set to the telephone-line mode and a DC-biased telephone line is connected, full monitoring and control is implemented. Each interface contains a switch that allows the telephone line to be seized (taken off hook) or hung up. Loop current is monitored when the interface is off hook. If a disconnect signal (a momentary break in loop current) is detected the interface will automatically return to the on-hook state. Each interface contains an LED indicator that lights whenever loop current is detected. Interface 2 also implements an auto answer function, automatically taking the telephone line to the off-hook state when ringing voltage is detected.

In many cases a “telephone line” is actually provided by a cellular telephone. This cellular telephone may provide an unbiased (no DC loop current) audio output. The standard audio mode was designed expressly to interface with this “cell phone” arrangement. In this mode, the interface’s loop current-specific features are disabled, and the interface appears electrically as a transformer coupled balanced audio input.

When in the standard audio mode, an interface’s front-panel switches are inactive. Also inactive is channel 2’s auto answer function. An LED associated with each interface displays when the standard audio mode is selected. Even during operation in this mode, the loop current LEDs remain active, serving as a useful diagnostic tool. They will display if your “standard audio signal” is actually a telephone line!

Voice Operated (VOX) Interrupt

The Model 2 contains circuitry to allow an audio signal to serve as both an interrupt

audio source and a control signal. This eliminates the need for a separate push-to-talk button or contact closure. The VOX feature allows an audio signal from a remote source, such as a two-way radio or telephone line, to serve as the interrupt source. The VOX function was optimized for detection of audio signals in the voice band. As voice detection is quite tricky to perform, great care was taken when designing this function.

Three audio sources can serve as the VOX input: receive audio from telephone interface 1, receive audio from telephone interface 2, or the auxiliary audio input. The auxiliary audio input is a separate line-level audio input that serves the VOX circuit only. A 3-position switch selects which source will be used. A second 3-position switch selects which IFB channel the VOX interrupt is assigned to, or if the function is not active. The VOX function can be assigned to only one IFB channel at a time. Each IFB channel contains an LED indicator light to display when a voice-activated interrupt is taking place.

Internal Interrupt Microphone

Contained behind the Model 2’s front panel is an internal interrupt microphone. Associated with the microphone are two switches, allowing the internal microphone to interrupt IFB channel 1, channel 2, or both.

Monitor Section

The Model 2 contains a simple but excellent monitor section. At the core is a 4 watt audio amplifier designed to drive an 8 ohm (or greater) loudspeaker. Associated with the monitor amplifier is a 3-position source select switch and a level control. The switch selects monitoring of IFB channel 1 or 2, as well as having an off

position. A click-free analog switch mutes the monitor output whenever the internal microphone or a Model 22 Access Station, if installed and configured, is interrupting either IFB channel.

Model 22 Access Station

The Model 22 Access Station provides the capability to add up to four additional interrupt locations. Model 22s are intended to be installed at positions convenient to producers, directors, or other personnel who need to “cue” talent and related personnel. The unit consists of a metal chassis containing two lighted push-button switches, unbalanced microphone and balanced line inputs, and status and control circuitry.

The two high-quality, back lit push-button switches provide access to the two IFB channels. The lights in the switches display when an interrupt is taking place on its respective channel. When a channel is idle, the light is lit dimly. An input select switch allows connection of a Model 11A gooseneck microphone or a line-level signal. The electronically balanced line-level input allows interfacing with other communications equipment, such as an intercom system.

The Model 22 can be configured to mute the Model 2’s monitor amplifier output. This function will prevent acoustic feedback from occurring when a Model 22 is located close to the Model 2’s monitor speaker.

Model 22 Access Stations are linked to the Model 2 Central Controller via 9-pin D-type female connectors. Each access station contains two connectors, allowing a simple daisy-chain installation. The nine leads carry all signals; audio, control,

status lamp (tally), and power. The Model 2 provides all power required by the access stations. The Model 25A 19-inch Rack Adapter is available to mount a Model 22 and a Model 11A gooseneck microphone in one space of a 19-inch rack. The Model 28A Panel Adapter allows a Model 22 and a Model 11A gooseneck microphone to be mounted in a panel opening.

Model 32 & Model 33 Talent Amplifiers

The Model 32 and Model 33 Talent Amplifiers are self-contained “belt pack” units that drive talent ear pieces or headsets. A single 3-conductor microphone-type cable links the Model 2 with the talent amplifiers. Each Model 32 and Model 33 contains both a male and female XLR-type connector, allowing simple “loop through” connection of multiple units. Up to four talent amplifiers can be connected to, and powered by, a single Model 2 Central Controller. On each talent amplifier the audio output signal is provided on a standard ¼-inch 2-conductor phone jack. An LED on each unit lights whenever power is present, providing setup assistance and user confidence. Identical in size, each is housed in a lightweight, yet rugged, aluminum housing. A belt clip allows it to be attached to belts, clipboards, scabbards, pizza boxes, production assistants, etc. An optional mounting adapter is available, allowing a Model 32 or 33 to be installed in a permanent location.

The Model 32 is intended for use by on-air personnel, and contains a source switch, along with an output level control. Either IFB channel 1 or IFB channel 2 can be sent to the talent, along with the desired audio “volume.”

The Model 33 is unique in that a “mix” of IFB channels 1 and 2 can be created. Two level controls, along with a source select switch, allows camera and production personnel to hear IFB cues from either or both channels. This allows IFB signals intended for both technician and talent to be simultaneously monitored.

Installation

In this section you will be installing a Model 2 Central Controller in an equipment rack. In conjunction with the Model 2, up to four Model 22 Access Stations can be installed. In addition, wiring can be installed for up to four Model 32 and 33 Talent Amplifiers.

Internally, the Model 2 has no configuration switches or trim pots to set. However, there are several reasons why you may need to access the “guts” of the unit:

- The factory-selected AC mains voltage will be either 120 or 220/240V, depending on the shipping destination. It may need to be revised for your installation.
- From the factory, the Model 2 is set to mute program audio when an interrupt takes place. If desired, a program “dim” function, rather than mute function, can be implemented.
- The standard audio routing for each of the two IFB channels is for the interrupt audio to be processed by the compressor/limiter circuits. Program audio, with its dynamic range unmodified, is sent directly to the output circuitry. For special applications, the program audio flow can be changed so that it too is routed through the compressor/limiters.

Refer to the Technical Notes section for details on revising these conditions.

In addition to the above situations, you may want to take a look inside and familiarize yourself with the unit on the rare occasion that it may need service. (The people here in the marketing department taught us never to say a unit may need to be fixed—service is much nicer!) We are proud of how the “guts” of the Model 2 look and how it is constructed so we encourage you to take a look!

On a more serious side, removing the Model 2’s cover with the AC mains cord connected exposes you to hazardous voltages.

Warning: Never remove the cover without disconnecting mains power. We make the assumption that anyone gaining access to the inside of our products meets the requirements for “qualified service personnel”—including knowledge of safety precautions.

Locating the Unit

Physical access and mechanical noise are the primary factors when choosing a mounting location. You don’t want a cooling fan blowing directly onto the internal microphone, nor do you want the microphone at the level of your navel. It is also a good idea to keep the Model 2 physically separated from other electronic devices that produce strong electrical fields. As a device that contains high gain audio stages, hum and noise pickup is possible through the chassis and associated cabling. Locating the unit away from devices such as power amplifiers, power transformers, and lighting controls will help to avoid pickup of unwanted signals.

Precautions were taken to limit the Model 2's bandwidth, minimizing the chance for RF pickup problems.

Mounting

The Model 2 is intended for rack mounting, requiring one 1.75-inch (4.5cm) rack space. It weighs a bit over 10 pounds (4.7kg), and operates on either 120 or 220/240V, 50/60Hz. The unit is secured to the front mounting rails of an equipment rack using two mounting screws per side. In addition to the front mounting "ears," we encourage you to secure the Model 2 from the back. Provision has been made for this to be easily accomplished. On each side of the Model 2's chassis are two threaded fasteners intended to secure user-fabricated mounting bars or brackets. Use standard 8-32 screws to secure the mounting brackets to the Model 2's chassis. To prevent damage to the Model 2's "guts," limit the screw length so that the threads extend into the chassis a maximum of 1/4-inch. Refer to Figure 1, located at the end of this guide, for a mechanical drawing detailing the fastener locations. This drawing will assist you in fabricating the mounting brackets.

Program Inputs

The Model 2 allows four line-level program audio sources to be connected. The input circuitry is designed for a nominal input level of +4dBu. A trim potentiometer is associated with each input, giving a ± 8 dB adjustment range. The trim pots are not intended for precise calibration, but strictly to allow the program input signals to be adjusted to the same relative level. A little attention to setting the trim pots will give better operational performance. It will allow an operator, using the front-panel

program switches, to rapidly change program inputs, while not giving large changes in level to users listening to the IFB channel. It is anticipated that the trim pots will be adjusted only upon initial installation or during maintenance, and are not considered an operator function. Refer to the Technical Notes section of this guide for details on setting the trim pots.

Program audio connections are made via four 3-pin female XLR-type connectors located on the back panel. The program input circuitry on the Model 2 is direct coupled, electronically balanced with an input impedance of 24k ohms. External load resistors must be added if your facility terminates all audio lines, e.g., with 600 ohms. Studio Technologies discourages terminating audio lines—but if you have to, you have to! Prepare the mating connectors so that pin 2 is positive (+ or hot), pin 3 is negative (– or cold), and pin 1 is shield. With unbalanced signals connect pin 2 to positive, and pins 1 and 3 to shield.

Auxiliary Audio Input

The Model 2 allows an auxiliary line-level audio source to be connected for use with the voice operated (VOX) interrupt function. Identical to the program inputs, the auxiliary input circuitry is designed for a nominal signal level of +4dBu. A trim pot is associated with the auxiliary input, giving a ± 8 dB adjustment range. The pot is not intended for precise calibration, but strictly to allow the AUX input level to be adjusted for correct VOX operation. It is anticipated that this pot will be adjusted only upon initial installation or during maintenance, and is not considered an operator function. Refer to the Technical Notes section of this guide for details on setting the trim pot.

The auxiliary audio connection is made via a 3-pin female XLR-type connector on the back panel. The auxiliary audio input circuitry is direct coupled, electronically balanced with an input impedance of 24k ohms. An external load resistor must be added if your facility terminates audio lines. Prepare the mating connector so that pin 2 is positive (+ or hot), pin 3 is negative (– or cold), and pin 1 is shield. With unbalanced signals connect pin 2 to positive, and pins 1 and 3 to shield.

The VOX interrupt function is quite specialized and may not be used regularly in your facility. For maximum flexibility, it may be best to terminate the auxiliary audio input to a patch point in the audio patch bay. In this way, a variety of audio sources can quickly be selected as the VOX interrupt input source. The VOX feature may sit unused for months or years, but when you need it there's no substitute! The Model 2's VOX interrupt works quite well, better than you may think. (Actually better than we thought, too, until we tested it!) Try it out and you may soon find more applications than you expected.

Talent Amplifier Output

The talent amplifier output is designed to supply power and audio signals for up to four Model 32 or 33 Talent Amplifiers. The talent amplifier output exits the Model 2 via one 3-pin male XLR-type connector. Pin 1 is common, pin 2 is +18Vdc modulated with channel 1 audio, and pin 3 is channel 2 audio. For convenience, it is expected that the talent amplifier output will be wired to a main distribution panel, along with microphone, camera, and other various connections. This will allow easy talent amplifier connection using standard flexible microphone cable. The distribution

panel does not need multiple talent amplifier output connectors which are “muled” from the Model 2's talent amplifier output. Each Model 32 and Model 33 Talent Amplifier has both a female and a male 3-pin XLR-type connector. This allows the talent amplifier interconnecting cables to be “looped” through the talent amplifiers. This will simplify and, in most cases, reduce the amount of cabling required to connect multiple talent amplifiers.

Line Outputs

Associated with each of the two IFB channels is an electronically balanced line-level output with a nominal signal level of +4dBu. The line outputs are capable of driving balanced or unbalanced, low or high impedance loads. The line outputs exit the Model 2 via two 3-pin male XLR-type connectors. Prepare the mating connectors so that pin 2 is positive (+ or hot), pin 3 is negative (– or cold), and pin 1 is shield. To connect to an unbalanced load connect pin 2 to positive (+ or hot) and pins 1 and 3 to shield.

Some installations may use the line outputs to drive wireless IFB transmitters. In other installations they may be used for special applications, such as feeding a satellite uplink. For maximum flexibility it is recommended that the line outputs be wired via audio patch points, even if you have a dedicated application.

The Model 2's audio quality and flexibility make it a useful tool for non-IFB applications. Not to “toot our own horn,” but the Model 2's sonic quality is as good as, if not better than most audio consoles, tape recorders, etc. As an example, the frequency response from program input to line output is better than $\pm 0.5\text{dB}$ from

20Hz to 20kHz. This makes using one of the IFB channels as a four input, one output audio source selector for an uplink application completely valid. Let the Model 2 become a useful part of your facility's "bag of tricks!"

Connecting Telephone Lines

Words of Caution: As with any product, installing the Model 2 requires a safety first approach.



Never install telephone wiring during a lightning storm. Never install telephone jacks in wet locations unless the jack is specifically designed for wet locations. Never touch non-insulated telephone wires or terminals unless the telephone line has been disconnected at the network interface. Use caution when installing or modifying telephone lines.

The Model 2 contains two telephone interfaces which can be individually configured to allow connection to a telephone line or to a standard audio signal. A telephone line is designated as such if it has a DC bias current associated with it. This type of signal is sometimes referred to as a "wet" signal. A standard audio signal is one that is isolated from any source of DC voltage. Some fax adapters associated with cellular telephones provide this type of "telephone" line. A standard audio signal is sometimes referred to as a "dry" signal. While this sounds confusing, contemporary applications sometimes refer to both types of signals as "telco." To a large production vehicle that pulls up to do a two-week golf tournament, a telco line is one provided by the local telephone company on an RJ11 jack. To a mobile ENG vehicle, a telco signal might come

from a cellular telephone which in most cases is a standard audio signal.

Here is a review of the important features of the Model 2's telephone interfaces:

Interface 1

- Telephone line or standard audio mode select switch on back panel
- Used to receive audio only
- Receive audio used as program and/or VOX source
- Front panel ± 8 dB receive level trim pot
- Switch allows manual off-hook and hang-up (telephone line mode)
- Auto disconnect upon break in loop current (telephone line mode)
- Operating mode and loop current status LEDs

Interface 2

- Telephone line or standard audio mode select switch on back panel
- Used to receive or send audio
- Receive audio used as program and/or VOX source
- Sends audio from either IFB channel
- Automatic answer of "ringing" telephone line (telephone line mode)
- Auto disconnect upon break in loop current (telephone line mode)
- Front panel ± 8 dB receive level trim pot
- Switch allows manual off-hook and hang-up (telephone line mode)
- Operating mode and loop current status LEDs

Setting the mode switches and connecting signals is quite easy. Set the telephone interface mode switches, located on the back panel, to the desired mode—either telephone line or standard audio signal. Use modular telephone cables to mate the Model 2's modular jacks (RJ11-type) with two more RJ11-type jacks. Technically, the Model 2's telco interfaces use 6-position modular jacks with pins 3 and 4 utilized.

If the telephone line mode is selected, the telco interfaces should, in most cases, terminate on an access panel of some sort. This will make rapid termination with telephone company-provided lines. Because of the presence of high voltage ringing signals, it is best not to route telephone lines through an audio patch bay.

If the standard audio mode is selected, a direct connection to the source device is acceptable, but connecting it via audio patch points provides better flexibility. In the standard audio mode the interfaces look like standard, transformer coupled audio inputs. Interface 1 has an input impedance of 2200 ohms. Interface 2 has an input impedance of 2200 ohms in the receive mode, and 700 ohms in the send mode. In standard audio mode, the interfaces are compatible with balanced or unbalanced signals. No shield connection is associated with the telephone interfaces. Audio signals should be connected to the telco interfaces, via a modular jack and cable, using shielded cable, with the shield wire connected to the appropriate point at the end opposite of the Model 2. The shield wire should remain unterminated at the Model 2's end.

The telco interfaces are designed to receive and, in the case of interface 2,

send audio signals at nominal levels that are correct for telephone circuits, but which are far lower than the typical +4dBu professional audio standard. The nominal receive signal level is expected to be -15dBu, the transmit level is -6dBu. Trim pots are associated with both interfaces, allowing the receive level to be adjusted over a ± 8 dB range. Special precautions may need to be taken when an interface is set for standard audio mode and +4dBu signals are going to be connected. These would include the use of an audio attenuator or "pad" for connecting receive audio, and the use of a line amplifier to achieve send gain from interface 2.

Access Stations

The Model 2 allows the connection of up to four Model 22 Access Stations. The Model 22 provides an unbalanced microphone input, a balanced line-level input, two lighted push button switches, and related circuitry to access the two IFB channels. Power is provided by the Model 2, so an external power source is not required. Nine-pin D-subminiature connectors link the Model 22 with the Model 2 Central Controller and, if desired, another Model 22. A 5-position screw terminal strip allows connection of a Studio Technologies Model 11A goose-neck microphone or a line-level signal.

There are three mounting methods appropriate for the Model 22: the Model 25A 19-inch Rack Adapter, the Model 28A Panel Adapter, or custom. The Model 25A 19-inch Rack Adapter allows the rapid installation of a Model 22 and a Model 11A gooseneck microphone in a single rack space. Refer to Figure 2 for details on how the Model 22 is physically positioned in

the rack adapter. Plenty of room remains on the right side of the rack adapter, allowing you to add custom switches, lights, or jacks as your installation may require.

The Model 28A Panel Adapter allows the installation of a Model 22 and a Model 11A gooseneck microphone in a “cut out” made in a desk, console, or other enclosure. Refer to Figure 3 for a mechanical drawing of the panel adapter and the required mounting hole size.

A custom Model 22 installation is any installation where you devise the mounting method! Refer to Figure 4 for a mechanical drawing showing the dimensions of the Model 22. This will assist you in implementing your own mounting method.

Contained on both the Model 2 and the Model 22 are standard 9-pin D-type female connectors. A “straight through” cabling scheme links the units together, with pin 1 connected to pin 1, pin 2 to pin 2, etc. Shielded cable is required as the two audio buses linking the Model 22s to the Model 2 are unbalanced. The shield should be connected to pin 1 on the 9-pin plugs. For reference, the following chart displays the signals associated with the access station connector:

| <u>Pin #</u> | <u>Function</u> |
|--------------|------------------------------|
| 1 | Common/Shield |
| 2 | Interrupt Audio, CH1 |
| 3 | Interrupt Audio, CH2 |
| 4 | +18Vdc |
| 5 | Interrupt Control, CH1 |
| 6 | Interrupt Control, CH2 |
| 7 | Lamp Voltage, CH1 |
| 8 | Lamp Voltage, CH2 |
| 9 | Monitor Speaker Mute Control |

For ease of installation, each Model 22 contains two 9-pin D-type female connectors wired in parallel. This allows signals to be easily “looped through” on their way to the next Model 22. For short cable runs, standard 9-pin video monitor extension cables, commonly used with personal computers, are an inexpensive and readily available way to link a Model 2 with a Model 22. Ensure that any cable assemblies you purchase use shielded cable, with the shield connected at pin 1 of both plugs.

For best performance, a maximum total cable length of 500 feet should be used to link Model 22s to the Model 2. Minimizing the cable length reduces the total exposure the unbalanced audio buses have to noise pickup, etc. Cable runs longer than 500 feet are possible but should be carefully checked for correct operation.

The Model 22 Access Station contains several configuration switches that must be set. The input select switch allows the unit to be set for a mic or a line-level input. In most cases the Model 11 gooseneck microphone, available from Studio Technologies, will be used with a Model 22. Setting the switch to the mic position activates the mic input terminals. The mic input is configured only for use with unbalanced electret-type microphones. The + terminal on the mic input provides current limited 5Vdc to power the electret microphone. Don't use a dynamic microphone as damage may occur. The – terminal is connected to the microphone's low signal lead. The connection marked SHLD is intended for the shield wire of the microphone cable; it doesn't carry signal.

The Model 11A Gooseneck Microphone is an unbalanced electret type, requiring an external source of DC power. The microphone utilizes a 3-conductor ¼-inch plug for interconnection. The tip lead brings DC power to the microphone, as well as having microphone audio superimposed on it. The ring lead is microphone common. The sleeve lead is a shield connection.

Included with the Model 11A is a mounting hardware kit. Included with the kit is a 3-conductor ¼-inch jack used to mate with the microphone's plug. At the factory a 3-conductor wiring harness assembly is attached to the jack. The wiring harness has a red-colored wire, a black-colored wire, and a shield wire. One end of the red wire is attached to the tip connection on the jack. The other end should be connected to the + terminal on the Model 22's microphone input. One end of the black-colored wire is attached to the ring lead of the jack. The other end should be connected to the – terminal on the Model 22's microphone input. One end of the shield connection is attached to the sleeve of the jack. The other end should be connected to the SHLD terminal on the Model 22's microphone input.

Setting the input select switch to the line position activates the line input, and the associated input trim potentiometer. The line input circuit is electronically balanced, capacitor coupled, with an input impedance of 24k ohms. Balanced or unbalanced signals can be connected. The input trim pot allows signals with a nominal level of –15 to +10dBu to be correctly interfaced. When connecting balanced signals the audio should connect to the + and – terminals. The shield wire can be connected to the SHLD

terminal associated with the mic input. Unbalanced signals require a bit more attention for correct operation. The signal high lead should be connected to the + terminal. The signal low/shield wire should connect to both the – terminal and the SHLD terminal. Failure to make this connection can result in large amounts of hum being induced into the interrupt signal.

If you have connected a signal to the line input terminals, set the trim pot only after installing the entire IFB system. Refer to the Technical Notes section of this guide for details on setting the trim pot.

The Model 22 contains a monitor mute function, which is intended to prevent acoustical feedback if the access station is located close to the monitor loudspeaker associated with the Model 2 Central Controller. When the monitor mute switch is set to the ON position, the monitor output is muted whenever an interrupt occurs from that access station.

Monitor Output

The Model 2 contains a 4 watt monitor amplifier which is intended to drive a small, efficient loudspeaker. A switch on the front panel selects whether IFB channel 1 or 2 will be monitored. The monitor output is accessible from the back panel using a ¼-inch 2-conductor jack. The output can drive 8 ohm or greater loads, and is quite "hi-fi." Ensure that both conductors of the speaker wiring are "floating" (isolated) from ground. This will prevent ground loops that could cause oscillation or other strange audio gyrations. We recommend using a good quality loudspeaker. If you do so we think you'll find the monitor output sounds quite nice. In our lab, we tested the monitor amp by connecting it to a JBL three-way speaker

cabinet, with a compact disc acting as our program source. The amp, within reason, really “kicked some tail!”

Connecting AC Mains Power

The Model 2 is factory configured to operate from AC mains power of either 120 or 220/240V, 50/60Hz. In most cases, units shipped to North America are factory selected for 120V operation and are supplied with an internal 0.5A, 5 x 20mm fast-acting fuse. Most units shipped outside North America are factory selected for 220/240V operation and are supplied with a 0.25A, 5 x 20mm fast-acting fuse. Before connecting the Model 2 to mains power, determine the actual mains voltage and confirm that the Model 2 has been configured correctly, as an incorrect setting could seriously damage the unit. Should it be necessary to change the unit’s operating voltage refer to the Technical Notes section of this guide. Because the Model 2 contains no power switch it will start operating as soon as mains power is connected.

The Model 2 uses an IEC standard connector to mate with the AC mains cord. Normally the cord supplied has a North American standard plug at one end and an IEC connector at the other. In non-North American applications the appropriate plug must be attached. The wire colors in the mains cord, in most cases, will conform to the internationally recognized CEE color code and should be wired accordingly:

| <u>Connection</u> | <u>Wire Color</u> |
|-------------------|-------------------|
| Neutral (N) | Light Blue |
| Live (L) | Brown |
| Earth/Ground (E) | Green/Yellow |

Operation

The Model 2’s Front-Panel Controls and Indicators

If you value equipment by the number of switches and lights per rack space, the Model 2 is really a good deal—there is more stuff crammed onto the front panel than we thought possible! Seriously, the designers had the difficult problem of getting maximum functionality into a single rack space. We had heated arguments about the feature list, what to include, what to delete. In the end, we feel that all important features were included. Once you understand all the functions, we think you’ll find the Model 2 quite powerful, yet easy and intuitive to use.

Looking at the Model 2’s front panel from the left to the right, you should note the functional groups: internal interrupt microphone, channel 1-related items, channel 2-related items, voice activated (VOX) interrupt, telephone interface 1, telephone interface 2, monitor amplifier, and power LED. We’ll discuss these groups in the following sections.

Internal Interrupt Microphone

The Model 2 contains an internal microphone which can be used to access either, or both, of the IFB channels. Two momentary action push button switches are located on the left end of the front panel and are labeled IFB 1 and 2. Pressing either switch mutes (or optionally dims) program audio, mutes the monitor speaker output, and connects the microphone to the selected IFB channel(s). The IFB status LED associated with each channel will light whenever its corresponding interrupt button is pressed. Notice that

sound enters the microphone via the small openings in the front panel above and slightly to the right of the switches.

Program Select, Level Adjustment, and Indicators

Two identical sets of controls and indicators serve IFB channels 1 and 2. Each channel contains six program select switches, two status LEDs, a program level control, and a 5-segment LED level meter. The six switches are used to select which of the four program inputs, and the receive audio from the two telephone interfaces, will serve as the program audio source(s). The switches were chosen to allow more than one source to be selected at a time. The ability to simultaneously depress and lock multiple buttons is not a defect, but is a feature which can be useful in special circumstances.

The red LED, labeled IFB, is lit any time program audio is being interrupted. There are three ways an interrupt can take place: by the internal microphone being activated, by a Model 22 Access Station being used, or via a control signal from the voice operated (VOX) interrupt function. The yellow LED, labeled VOX, is lit any time interrupt is caused by the VOX function.

The program level control allows the program audio signal to be adjusted relative to the interrupt audio level. The interrupt level is internally fixed and serves as the reference. The gain structure was configured so that the level control set for 50 percent of rotation (12 o'clock) will give a program level approximately equal to the interrupt level. This statement is made under the assumption that a +4dBu program signal is selected and its associated input trim pot is correctly set.

The 5-segment LED level meter displays the internal level of the composite (program and interrupt) IFB signal. The three green LEDs are lit with signals in the normal operating range. The yellow LED lights with a signal slightly higher than average. The red LED lights when signal levels are in the "headroom" area. The ballistics of the meter are a cross between that of a VU meter and a peak (PPM) meter. (We affectionately refer to it as a "PU" meter!) The meter should prove useful during installation and maintenance, as well as during normal operation.

A typical interrupt signal will light the green LEDs, with peaks lighting the yellow LED. The internal compressor/limiter will keep most interrupt signals from lighting the red LED. When an interrupt is not taking place, the level meter will reflect the level of the program audio source. Setting the program level control to occasionally light the yellow LED will give a program level approximately equal to the interrupt level.

Voice Operated (VOX) Interrupt

The Model 2 contains a specialized function that allows an audio signal to automatically interrupt the program signal. By contrast, using the Model 2's internal microphone requires an explicit action by the operator, i.e., pressing a button to cause an interrupt. In some cases, this explicit action is simply not possible. An example would be a director giving cues via a two-way radio or a telephone line. The VOX circuitry creates an interrupt control signal by detecting energy in the voice band. This control signal acts on the selected IFB channel, interrupting program audio and routing VOX audio in its place. The VOX interrupt can be assigned

to either IFB channel 1 or 2, but not to both simultaneously.

The VOX interrupt function is only sophisticated from an internal-circuitry standpoint. Operation is quite simple, with only two switches to set. The input switch allows one of three audio sources to be connected to the VOX input: audio from the auxiliary audio input, receive audio from telephone interface 1, or receive audio from telephone interface 2. The output switch is used to select whether the VOX interrupt function is off (not used), or is assigned to interrupt IFB channel 1 or 2. VOX operation can commence as soon as the output is assigned to one of the channels. VOX interrupt activity can be noted by observing the yellow VOX LED associated with the assigned IFB channel.

Telephone Interface 1

Two status LEDs, one switch, and one trim potentiometer are associated with telephone interface 1. The yellow LED, labeled STD, is lit whenever the interface is set for the standard audio mode by the switch on the back panel. The red LED, labeled LC for loop current, lights any time DC current is flowing through the interface. Normally in the standard audio mode, loop current would not be flowing through the interface and the LC LED will not be lit. In most cases the loop current LED lighting would indicate that the mode switch should be changed to the telephone line position.

The interface control switch, active in the telephone line mode, allows the interface to be taken off hook or hung up. Momentarily pressing the switch to the up position, labeled MAN OH for manual off hook, places the interface in the off-hook state. If loop current is detected, the interface

will stay in the off-hook state and the loop current LED will light. If loop current is not detected, the interface will return to the off-hook (idle) state after a few seconds. Momentarily pressing the switch to the down position, labeled HANG UP, immediately disconnects the interface from the telephone line. In the standard audio mode, the interface control switch is not active because the standard audio mode places the interface permanently in what is effectively the off-hook condition.

Telephone line audio signals can vary greatly in level on a call-by-call basis. To counter this problem, a level trim potentiometer is provided for the operator, allowing adjustment over a ± 8 dB range. A quiet signal can be boosted, and a "hot" signal can be attenuated. The trim pot is accessible via a small hole in the front panel, directly to the right of the interface control switch.

Telephone Interface 2

Two status LEDs, two switches, and one trim potentiometer are associated with telephone interface 2. The yellow LED, labeled STD, is lit whenever the interface is set for the standard audio mode by the switch on the back panel. The red LED, labeled LC for loop current, lights any time DC current is flowing through the interface. In the standard audio mode, loop current will not usually be flowing through the interface. If it is, the red LED will light. In most cases the loop current LED lighting would indicate that the mode switch should be changed to the telephone line position.

The interface control switch, active in the telephone line mode, allows the interface to be taken off hook or hung up. Momentarily pressing the switch to the

up position, labeled MAN OH for manual off hook, places the interface in the off-hook state. If loop current is detected, the interface will stay in the off-hook state and the loop current LED will light. If loop current is not detected, the interface will return to the on-hook (idle) state after a few seconds. Momentarily pressing the switch to down position, labeled HANG UP, disconnects the interface from the telephone line. An apparent problem occurs if the switch is used to place the interface in the off-hook state and then immediately used to hang up the interface. A pause of approximately three seconds is required before the manual hang-up function becomes active after the interface is manually taken off hook. This is due to the charge time of a debounce capacitor required in the auto answer circuit. This capacitor is not associated with interface 1 and the pause is not required. In the standard audio mode, the interface control switch is not active because the standard audio mode places the interface permanently in what is effectively the off-hook condition.

A second switch controls the audio routing through interface 2. In the center position, audio is received from the telephone line. In the up position, labeled SEND CH1, composite IFB channel 1 audio is sent out the interface. In the down position, labeled SEND CH2, composite IFB channel 2 audio is sent out the interface. The overall send level is not adjustable. Just like the talent amplifier and line outputs, the interrupt level is fixed, and the program level is adjusted in reference to it. The send level has been internally configured to give the highest signal level possible, without overloading the telephone company equipment.

On interface 2 a level trim pot is provided, allowing the receive audio to be adjusted over a ± 8 dB range. A quiet signal can be boosted, and a "hot" signal can be attenuated. The trim pot is accessible via a small hole in the front panel, directly to the right of the routing control switch. The trim pot is active only in the receive mode.

Monitor Output

A level control and source select switch is associated with the monitor section. The level control adjusts the output level sent to the external monitor speaker. IFB channel 1 is monitored when the source select switch is in the up position. In the down position, channel 2 is monitored. The middle position is labeled OFF and the monitor amplifier is, as you might guess, off!

Power Indicator Light

A red LED indicator light located on the right side of the front panel is lit any time mains power is applied to the Model 2. Since the Model 2 does not contain a power switch, the power LED should be lit at all times that power is applied to your equipment racks.

It's Time to Use the System!

Operation can commence after the Model 2 and related equipment have been installed and connected. The power LEDs on the Model 2 and, if present, Model 32 and/or Model 33 Talent Amplifiers should be lit. If one or more Model 22 Access Stations are installed, their push button switches should be dimly lit.

Ear pieces should be connected to the talent amplifiers. Both the Model 32 and Model 33 Talent Amplifiers utilize a 1/4-inch 2-conductor phone jack for their audio output. On the Model 32, either IFB channel can be selected as the audio source.

On the Model 33, either or both IFB channels can be selected as the audio source(s). The level control(s) should be adjusted for the desired level during an interrupt from the Model 2's internal microphone. Note that the even when the level control(s) are set to the fully counterclockwise position, the audio output will not be fully "off." This ensures personnel will never (hopefully!) miss an important cue because a level control was accidentally turned "off."

Once the talent amplifier's output level has been set, a Model 2 program source can be selected and the program level control on the Model 2 adjusted as required. Remember that the nominal interrupt level is internally set in the Model 2, and acts as the system reference.

In the following paragraphs we'll describe several simple procedures you can use to try out the Model 2's features.

Connect a high quality audio source, e.g., compact disc player, to a program input. Select it as the program audio source for one of the IFB channels. Set the program level control to get the yellow meter LED lighting on signal peaks. Test the monitor amp—it should let you "rock out" pretty well. If not, put in a maintenance request for a better speaker!

Bring an audio source into the auxiliary audio input and test the VOX interrupt feature. Set the VOX input switch to the middle position, connecting the auxiliary audio input to the VOX circuitry. Use the VOX output switch to assign the VOX output to one of the IFB channels. On the channel you selected for VOX interrupt watch the VOX and IFB status LEDs light when signal is detected. Use the monitor amplifier to monitor VOX interrupt activity.

Try receiving audio via telephone interface 1. Use the receive audio as a program source. Use the receive level trim pot to vary the receive audio level. Use the receive audio as a source for the VOX interrupt function.

Telephone interface 2 has more features; try them all. If set for the telephone line mode, let the interface automatically answer an incoming telephone call. Use the interface to receive, as well as send audio. Use the receive audio as a program source. Use the receive level trim pot to vary the receive audio level. As with interface 1, use the receive audio as a source for the VOX interrupt.

Test the Model 22 Access Stations. Is the interrupt audio loud and clear? Observe the status lamps inside the push button switches. Do the appropriate lamps light fully bright when an interrupt takes place? If an access station is configured to mute the Model 2's monitor output, ensure that the monitor speaker does mute during an interrupt.

In all cases, you should hear clear, click-free audio. We intended the Model 2 to sound great—if not, call us for technical help. A completed installation should be reliable, easy to use, and perform to high sonic standards. Questions and comments from the field are welcomed and encouraged!

Technical Notes

Schematic Diagrams

Schematic diagrams are provided to all purchasers of IFB Plus systems. The schematics show the graphical representation of all the electronic components,

along with their electrical value and connections. Traditionally, a problem with schematics has been the decimal point marking. It either disappears due to bad printing, or dust, dirt or other imperfections end up looking like decimal points. For clarity, Studio Technologies has adopted a more “European” component marking scheme. Upon first review it may seem quite confusing, but it can eliminate problems. For resistors, the designation “K” for kilo (1000) has been moved to the decimal point position. A 4700 ohm resistor is shown as 4K7, rather than 4.7K. An example for a one percent value, a 49900 ohm resistor would be shown as 49K9. For capacitors, the letter “r” is simply substituted for the decimal point marking. A 0.47uf capacitor is shown as r47uf. Once you are accustomed to this system you may well prefer it.

Definition of Level

Studio Technologies has opted to use the dBu designation as it seems to be quite rational. Using dBm was fine when all audio line outputs were terminated with 600 ohm loads. In this way it was easy to say that 0dBm is 1 milliwatt dissipated in the known load (i.e., 0dBm across 600 ohms will measure 0.7747V). In current situations an output is rarely terminated in 600 ohms; generally 5k ohms or higher. The dBu designation is better because it refers to dB referenced to 0.7747V, with no reference to load impedance. This takes into account the current audio scene where most equipment has a low output source impedance, and a high input impedance.

Revising Mains Voltage

The Model 2 can operate from mains power of either nominal 120 or 220/240V. Internal “straps” select the operating voltage. Follow this section if a change of operating voltage is required.



The following procedures must be performed by a qualified technician. Operating the Model 2 with the cover removed exposes the technician to points in the power input section with hazardous voltages.

- 1) Ensure that the mains power cord is removed from the Model 2's power connector on the back panel.
- 2) Remove the top cover via the four 6-32 button head cap screws.
- 3) Locate the power supply jumper straps. They are directly adjacent to the power transformers on the right side of the circuit board. The circuit board legend shows the designated locations for the two operating voltages. From the factory, 0 ohm “resistors” are used for the straps. These resistors are really just encapsulated jumper wires. For 120V operation, two “0 ohm” jumper straps are installed for each of the three power transformers (total of six straps). For 220/240V operation one strap is associated with each transformer.
- 4) Review the present configuration. If a change is required, use a soldering iron and appropriate tools to revise the straps. With care, the changes can be made without removing the circuit board from the chassis. Removing the circuit board from the chassis is a painful and time-consuming experience. The voltage selection straps can be removed and installed from the component (top) side

of the circuit board. Ensure that the ends of the straps do not extend below the circuit board so as to touch, or even come near the bottom of the chassis. Failure to heed this warning can result in safety, reliability, and operational problems. Confirm that the required straps have been installed for all three transformers.

- 5) If the mains voltage was changed, replace the fuse with the correct value: 0.5A for 120V, 0.25A for 220/240V. The fuse is a 5 x 20mm fast-acting type.
- 6) Replace the top cover and secure it using the screws.
- 7) Before reconnecting mains power, use an ohm meter to ensure that none of the straps leads have shorted to metal chassis below the circuit board.
- 8) Reconnect the mains power and check the Model 2 for correct operation.

Dim/Mute Function

From the factory, program audio is set to mute upon interrupt. If level “dimming” rather than full muting is desired, a simple modification can be performed by a qualified technician.



The following procedures must be performed by a qualified technician. Operating the Model 2 with the cover removed exposes the technician to points in the power input section with hazardous voltages.

- 1) Ensure that the mains power cord is removed from the Model 2's power connector on the back panel.
- 2) Remove the top cover via the four 6-32 button head cap screws.

3) Referring to page 2 of the Model 2's schematic diagram, find the resistor identification numbers for the dim resistors. From the factory, resistors are not inserted into these locations. If resistors are installed, someone has beaten you to the punch and already performed this modification!

4) Refer to the chart located in the lower left corner of page 2 of the schematic. The chart gives resistor values corresponding to several “dim” values. The level in dB refers to the program level drop that will occur during an interrupt. After selecting and acquiring the desired resistors, prepare them for insertion into the circuit board. With care, the resistors can be added without removing the circuit board from the chassis. Bend the leads so that they are 1/2-inches apart, allowing them to easily drop into the resistor locations. Trim the leads so that once inserted and soldered into the board, the ends of the leads will not touch the chassis below the board. Again, ensure that the ends of the straps do not extend below the circuit board so as to touch, or even come near the bottom of the chassis. Failure to heed this warning can result in operational problems.

- 5) Replace the top cover and secure it using the screws.
- 6) Reconnect the mains power and check the Model 2 for correct operation.

Alternate Program Audio Routing

Refer to the Model 2 block diagram, located at the end of this guide, when reading this section. The default audio routing of the program audio signal is to join interrupt audio after the compressor/limiter. This means that the original dynamic range of the program audio

is maintained. The interrupt audio is processed by the compressor/limiter so as to prevent the talent from being “blasted” by an excessive interrupt level. In special cases, it may be desirable for the program audio also to be processed by the compressor/limiter. Provision has been made on the Model 2’s circuit board to implement this change.

A possible use of this alternate routing is where the Model 2 is consistently used in locations where the talent is exposed to loud ambient sound levels. Increasing the average program level by processing it with the compressor/limiter can increase intelligibility. However, a serious side effect is that the processed program audio can prove to be much more fatiguing to the ear. The talent may complain that the IFB feed seems to be “annoying.” Be careful before going ahead and changing the signal flow.



The following procedures must be performed by a qualified technician. Operating the Model

2 with the cover removed exposes the technician to points in the power input section with hazardous voltages.

- 1) Ensure that the mains power cord is removed from the Model 2’s power connector on the back panel.
- 2) Remove the top cover via the four 6-32 button head cap screws.
- 3) Referring to page 8 of the Model 2’s schematic diagram, find the two resistor identification numbers for the resistors that implement the standard audio routing. Remove these two resistors from the circuit board.

- 4) Now, referring to page 6 of the schematic diagram, find the resistor identification numbers for the resistors that implement the optional audio routing.

- 5) After acquiring two 2K00 resistors (2000 ohm, 1%, ¼-watt), prepare them for insertion into the circuit board. With care, the resistors can be added without removing the circuit board from the chassis. Bend the leads so that they are ½-inches apart, allowing them to easily drop into the resistor locations. Trim the leads so that once inserted and soldered into the board, the ends of the leads will not touch the chassis below the board. Again, ensure that the ends of the straps do not extend below the circuit board so as to touch, or even come near the bottom of the chassis. Failure to heed this warning can result in operational problems.

- 6) Replace the top cover and secure it using the screws.

- 7) Reconnect the mains power and check the Model 2 for correct operation.

Nominal Input Level—Program and Auxiliary Audio Inputs

From the factory, the nominal input level of the program and auxiliary audio inputs is +4dBu. This level, along with the ±8dBu level trim adjustment, allows most signals to be correctly interfaced. There may be the rare case where an audio source with a lower nominal signal level may need to be connected. A simple change can reduce the nominal input level of any of the four program inputs, or the auxiliary audio input. To reduce the nominal input level from +4dBu to -2dBu change the differential receiver integrated circuit from the SSM-2143 to the SSM-2141. The ‘2143, used in the stock Model

2, is internally set for a gain reduction of 6dB. The '2141 is a unity gain device. The two devices, manufactured by Analog Devices, are pin for pin compatible so removing one and inserting the other is all that is required. Be certain to observe all safety precautions when accessing the inside of the Model 2. Should you have trouble obtaining SSM-2141 device, please contact Studio Technologies for assistance.

Disabling the Auto Answer Feature

In the telephone line mode, telephone interface 2's circuitry will automatically go off-hook upon detecting ringing voltage on the telephone line. This feature can be very useful, allowing another site to access the Model 2 without operator intervention. There may be cases where this feature is not desired, and the auto answer function can be disabled. Referring to page 5 of the Model 2's schematic diagram, observe the ring detection circuit in the lower left section of the page. A 5K6 resistor (5600 ohm, 1-watt) is in series with the optocoupler. Remove this resistor to disable auto answer. Remember to be careful inside the cabinet. Disconnect mains power prior to taking off the cover!

Voice Operated (VOX) Interrupt Release Time

The VOX interrupt circuit was designed to have a fast detect time and a relatively long release time. The fast detect time ensures that the beginning of a word will not be lost. The slower release time keeps the circuit from "modulating" during normal English language speech patterns. This release time was scientifically determined—we gathered a bunch of people in our lab, "listened" to a number of different release times, then chose the favorite.

Actually, we think the selected time works quite well. However, you may have a different opinion. (Do beans belong in chili? Is Elvis really dead?) The release time is set using one capacitor. Referring to the right side of page 7 of the Model 2's schematic, locate the r33uf (0.33uf) capacitor connected to the output of the synchronous half-wave rectifier. Reducing the capacitance to r22 (0.22uf) or r1 (0.1uf) will shorten the release time. Increasing the capacitance to r47 (0.47uf) or 1uf, will increase the release time. Use safety precautions if you will be performing this, or any other, modification.

Line Output Nominal Level

The nominal level of the line outputs is +4dBu. This should be well-suited for most professional applications. However, the line output stage is such that if you require a different nominal output level, you can achieve it by simply changing one resistor per channel. Refer to page 9 of the Model 2's schematic to observe the two identical line output stages. Audio enters the line driver stage at the internal nominal operating level of -10dBu. Each channel's composite IFB signal enters a section of operational amplifier which is configured to add 8dB of gain, bringing the nominal level to -2dBu. This signal connects to an SSM-2142 differential line driver integrated circuit. By the very nature of a balanced line driver a 6dB level boost is achieved. The nominal output level is now +4dBu.

You might enjoy a quick explanation of why 6dB is added by a differential output stage. We'll use the example of an input signal to the differential line driver chip which, upon taking a "snapshot" view, is swinging positive to a level of +2V.

Observing the balanced output at that very same instant, the “high” output is swinging +2V, while the “low” output is swinging -2V. The unbalanced input has an excursion of 2V, but the balanced output had an excursion of 4V (+2V to -2V). Since voltage gain in dB is equal to $20 \log V_{out}/V_{in}$, calculating our example you get $20 \log 4/2 = 6\text{dB}$! Another side note, this is 6dB boost is exactly why the SSM-2143 differential line receiver, used the Model 2’s program input circuits, contains a fixed 6dB attenuation. The ‘2143 gets rid of the 6dB gain created by a differential driver, saving headroom and correctly matching equipment levels.

Anyway, to modify the nominal output level requires you to change the gain of an operational amplifier by changing the value of its feedback resistor. Refer to the chart on page 9 of the schematic diagrams for several output levels and the corresponding resistor values. If you need an output level that requires less than unity gain from the op-amp you can do it, but be careful. If you choose a feedback resistor less than 10KΩ ohms a potential stability problem arises. To eliminate the chance of a problem, connect a 100pf capacitor in parallel with the feedback resistor to reduce the open loop gain.

As with all changes to internal Model 2 circuitry, taking a safety first approach is required. Disconnect mains power before removing the Model 2’s cover.

Setting the Program Input Level Trim Pots

There is no hard and fast rule on how to best adjust the trim pots associated with the program inputs. As mentioned in the installation section, the pots are provided

simply to allow the relative levels of the program input signals to be equalized. This will allow minimal level changes when an operator is switching between the four program inputs. A simple method of using the trim pots to “calibrate” the program input levels is to start by connecting an AC VTVM to the line output of IFB channel 1. Set the front-panel program level control associated with IFB channel 1 to the middle position (12 o’clock or 50 percent of rotation). Set the four program level trim pots to 50 percent of their rotation. Set the four program sources to deliver their normal operating signal level to the Model 2’s program inputs. These signals could be in the form of alignment tones, or actual program material. Use the program select switches to select, one at a time, the four program inputs. The line output should give an output level of +4dBu nominal, with +8 to +12dBu probable on peaks. The actual output level is not important, and a lower level is much better than a “hotter” average level. After observing the relative strengths of the four sources, use one or more of the trim pots, if required, to get an equal average level from the four sources.

If you have a source that is especially low in level, e.g., -10dBu, all is not lost. While getting a -10 to +4 level booster box is a good idea, the level trim pots can come to the rescue. On the inputs that have signal sources of nominally +4dBu, set their trim pots fully counterclockwise, reducing their input sensitivity by approximately 8dB. On the inputs that have the -10 sources connected, set their input trim pots to fully clockwise, adding 8dB of input sensitivity. You have now equalized the 14dB (+4 to -10) level difference using the trim pots! Using the program input switches, you

now should find relatively equal audio levels. Use the AC VTVM, connected to IFB channel 1's line output, to "tweak" the trim pots.

If you don't have an AC VTVM handy, or if you're not concerned about exact calibration, use one of the LED level meters on the front panel to set the trim pots. Actually, if your ears are pretty good use them, and no meters, to set the trim pots to get equal levels—that's what we would do if we were in the field! Confirm your subjective adjustment with the LED meter and you should be set.

Setting the Line-level Trim Pot on the Model 22 Access Station

The Model 22's line input circuitry allows balanced and unbalanced signals with a nominal level of -15 to $+10$ dBu to be correctly interfaced. The system is designed to have the Model 22 send interrupt signals at a signal level of -10 dBu to the Model 2 Central Controller. A level adjustment trim pot on the Model 22 allows the various signal levels to be adjusted to give the desired signal strength. Set the trim pot only after installing the entire IFB system. Start by connecting an AC VTVM across the two test points, labeled COM and AUDIO, on the Model 22's circuit board. Then, while speaking into the microphone, headset, or other device that produces the line-level signal, adjust the trim pot to give an average level of approximately -10 dBu on the meter. Peak signals should fall in the -5 to 0 dBu range. This setting should result in a clean, clear interrupt signal, without excess compressing by the Model 2's circuitry.

Model 32 and 33 Output Level

By design, the output level on the Model 32 and Model 33 Talent Amplifiers cannot be set to fully "off." While the output level can be substantially attenuated, it never can be set for full attenuation. This was to ensure that talent personnel could never accidentally be fully "isolated" from their program or IFB source. There may be special cases where full attenuation is desired. This might be especially true with the Model 33 Talent Amplifier, where a mix of the two IFB channels can be achieved. Referring to the Model 32 or Model 33 schematic diagram, observe the 200 ohm resistor that is connected between circuit common and the counterclockwise connection of each potentiometer. This resistor prevents full attenuation. By replacing this 200 ohm resistor with a "0 ohm" resistor or jumper strap, full attenuation can be achieved.

Circuit Descriptions

The following paragraphs describe the circuitry of the Model 2 Central Controller, Model 22 Access Station, and Model 32 and Model 33 Talent Amplifiers.

This information will help you understand how the units work and, if required, help identify where a failure may be located. Please refer to the block diagrams, located at the end of this guide, and the schematic diagrams, located in the separate schematic packet, while reading this material.

Model 2 Central Controller

Power Supplies

The Model 2 contains three independent power supply circuits. It was felt that reliability would be enhanced by splitting the circuitry loads, and then optimizing a power supply for each. Using this scheme, the Model 2 will run reliably, even with wide swings in ambient temperature, varying operating duty cycles, and mains voltage fluctuations. The result is a unit that should prove quite hard to kill! The power supplies use separate step down transformers, the primary side of each containing two 120V windings. This allows them to be configured for nominal mains voltages of 120 or 220/240V. For 120V operation the primaries are connected in parallel; for 220/240V operation they are connected in series. The configuration is performed using jumper straps on the circuit board. For safety, a fuse is in series with the incoming mains power.

Because the Model 2 is intended for continuous operation, a power switch is not included. This serves several purposes: eliminating the chance of a power switch being accidentally turned off, maintaining physical isolation between the nasty 50/60Hz fields and the sensitive analog circuitry, and eliminating the physical space required by a switch.

The first power supply generates filtered and regulated $\pm 12\text{Vdc}$. Its transformer has dual 17V secondaries which are connected in series. The series connection point provides circuit common, as well as being strapped to the metal chassis and the ground pin of the power entry connector. The transformer's secondary is fed to a full wave diode bridge. The output

of the bridge is filtered with electrolytic capacitors, producing nominal $\pm 24\text{Vdc}$.

Two integrated circuit regulators produce $\pm 12\text{Vdc}$ from the unregulated $\pm 24\text{Vdc}$. Capacitors on the outputs of the regulators provide stability. Interesting technical note department: notice that a diode is connected from the output pin of each regulator to circuit common. These serve to keep the $\pm 12\text{Vdc}$ rails at, worst case, one diode drop (0.7V) away from its ground pin, i.e., the +12V regulator will, worst case only, go to -0.7Vdc . This is important when supplying bipolar loads, such as operational amplifiers. Without these diodes the regulators can "latch-up" upon mains power being applied or removed. When mains power is initially applied one of the supplies can "come up" (get to its operating voltage) sooner than the other. This voltage is fed back through the loads (e.g., the op-amps) to the output pin of the other regulator that is still coming up to full voltage. Upon seeing this unexpected opposite polarity voltage on its output pin, the regulator may get very unhappy, possibly latching into a nonoperating state, drawing lots of current and burning up! The protection diodes keep this condition from happening.

The Model 2 contains an LED indicator light that displays the presence of mains power being provided to the unit. The LED is powered by the -12Vdc power supply bus.

The second power supply generates unregulated nominal $+34\text{Vdc}$. Its transformer has dual 10V secondaries which are connected in series. The 20Vac, which under low to moderate loads is quite a bit higher, is fed to a full wave diode bridge and a electrolytic filter capacitor which

produces nominal +34Vdc. The negative pin of the bridge is connected as the circuit common, as well as being strapped to the metal chassis and the ground pin of the power entry connector. The unregulated +34Vdc is used by the talent amplifier output circuit.

The third power supply generates unregulated nominal +25Vdc, and regulated +18Vdc. Its transformer has dual 17V secondaries which are connected in parallel. The 17Vac is fed to a full wave diode bridge and a electrolytic filter capacitor which produces nominal +25Vdc. The negative pin of the bridge is connected as the circuit common, as well as being strapped to the metal chassis and the ground pin of the power entry connector. The unregulated +25Vdc is used by the monitor amplifier and lamp output circuits. The lamp outputs are used to drive indicator lights in Model 22 Access Stations.

The +25Vdc is also fed to an integrated circuit regulator which produces +18Vdc for use by the access stations. A capacitor on the output of the regulator provides stability. The +18V regulator acts as much as a current limiter as it does a regulated power supply. The regulator limits the amount of short current that can be drawn by the access stations. In this way a shorted access station or related cabling will not bring “down” or damage the Model 2.

For service purposes, test points are included on the power supply buses: unregulated +34Vdc, unregulated +25Vdc, 12Vdc, and +18Vdc. In addition, two circuit common test points are included—one on the left side of the board and one on the right side.

Wonderful Integrated Circuits from Analog Devices

The Model 2 takes advantage of an excellent audio specific series of integrated circuits from Analog Devices. Using these parts allowed literally hundreds of components to be saved. More importantly, performance levels were achieved that would have been difficult, if not impossible, to obtain with more conventional circuitry. These parts have the common prefix of SSM, indicating their roots in a company called Solid State Microelectronics for Music, purchased, by way of Precision Monolithics, a few years ago.

Program Inputs

The Model 2 contains four identical program input circuits. The program inputs are designed to receive balanced signals with a nominal level of +4dBu. A trim potentiometer associated with each program input allows ± 8 dB of input variation. Now is a good time to note that the Model 2's internal operating level is -10dBu. This was selected to optimize audio performance—maximizing the signal-to-noise ratio and allowing ample headroom. The exact purpose of the program input circuits is to receive the program audio, separate out hum and noise, unbalance it, and attenuate it to the -10dBu internal operating level. Each circuit contains a differential input integrated circuit, followed by a variable gain reduction stage. The program input signals are direct coupled to SSM-2143 differential (balanced) line receiver integrated circuits. The '2143 has excellent common mode rejection, low noise, and high slew rate. It contains two internal 12k ohm series input resistors, individually laser trimmed for accuracy. By design, the '2143 provides 6dB of level reduction.

The nominal -2dBu signal is capacitive coupled to an operational amplifier configured as a variable attenuator. The coupling capacitors are nonpolar type, allowing for DC voltages of unknown polarity to be received on the program inputs. The output of the op-amps have nominal signal levels of -10dBu and are direct coupled to the program select switches. Small capacitors in the feedback loop of the op-amps ensures stability at the less than unity gain implementation.

Program Select, Program Muting, and Program Level Control

Each IFB channel contains a group of six program select switches. These switches allow one or more of the program sources to be selected from among the four program inputs and the receive audio from the two telephone interfaces. During the design phase, the switches were carefully specified to allow more than one program source to be selected at one time. This feature can prove invaluable in special applications. The output connections of the switch sections are connected to operational amplifiers configured as unity gain summing amplifiers.

The output of the summing amplifiers are connected to sections of SSM-2400-series analog switch, providing program audio muting during interrupt. These switches perform a click free off-to-on and on-to-off transition by internally generating a ramp control signal. This ensures a very “clean” transition from program audio to interrupt audio and vice versa. Optionally, by adding resistors in parallel with the analog switches, program “dimming” rather than muting can be implemented.

The output of each analog switch is connected to a potentiometer. The

potentiometers exhibit a log (audio) taper, setting the level of program audio relative to the fixed nominal -10dBu internal level of the interrupt audio.

Interrupt Audio Routing and Summing

Two identical circuits control interrupt audio routing. The composite interrupt audio signals are derived from two operational amplifiers configured as summing amplifiers. Four audio sources can enter the summing junctions: internal microphone audio, access station audio, voice activated (VOX) interrupt audio, and program audio. All audio sources are controlled by sections of SSM-2400-series analog switch. These switches ensure clean, click-free audio transitions. The outputs of the interrupt summing op amps are connected to the compressor/limiter circuits. Although program audio can enter the interrupt audio summing amplifiers, Model 2s are not factory-set to provide this function. The standard audio routing combines program audio with interrupt audio after the compressor/limiter. Resistors can be added to the Model 2's circuit board (after removing two others) to route program audio into the interrupt summing amplifiers.

Compressor/Limiters

Interrupt audio, and optionally program audio, is processed using two compressor/limiter circuits, one for each channel. Another Analog Devices integrated circuit, the SSM-2120, is used in creating the compressor/limiters. The '2120 provides—along with some discrete resistors, capacitors and diodes—everything required to implement two channels of studio-quality dynamic range control. Signal from each of the interrupt summing amplifiers enters the '2120's control and rectifier sections.

A DC signal is derived by the rectifier, and fed back into the control section. The circuit implements a true dual-slope processor, first compressing in an approximately 4 to 1 input-to-output ratio, and then going to infinite compression, i.e., hard limiting. This circuit ensures that the talent will get even, intelligible interrupt audio. Even screaming directors will have a difficult time fooling this circuit!

Current to Voltage Converter/Summing Amplifiers

The output of each SSM-2120 section is fed to a section of operational amplifier. Each op-amp is implemented as a current to voltage converter, as the '2120 provides only a current output. The op-amps get double duty as they sum (combine) the interrupt audio with program audio from the program level control. The output of the op-amps is the composite audio for the channels. The composite audio for each channel is sent to five points: talent amplifier output, line output, telephone interface 2, level meter, and monitor output select switch.

Internal Microphone

The Model 2 contains an internal electret microphone, along with front-panel switches and control circuitry. A microphone preamplifier is created using one section of low noise operational amplifier. Power is provided to operate the FET preamp in the mic. The microphone audio signal is capacitive coupled to the op-amps's non-inverting input. To provide optimal voice transmission, the capacitor was selected to roll-off low frequency input signals; the 3dB down point is approximately 105Hz. Two fixed resistors set the gain of the preamp. The output of the op-amp is capacitive coupled to two

sections of SSM-2400-series analog switch, part of the interrupt audio routing circuit.

Voice Operated (VOX) Interrupt

To the Model 2's designers, the VOX circuitry is the most interesting as it combines analog and digital functions to perform a function that, historically, has not worked very well in most equipment. Including a VOX circuit was contemplated with some trepidation. Don't get us wrong, it's not that most VOX circuits are unusually complicated, it's just that they don't often work very well!

Audio enters the VOX circuit via a 3-position source select switch. The switch selects between audio from the two telephone interfaces, and the auxiliary audio input. The auxiliary audio input circuit is identical to those used by the program inputs. The output of the source switch connects to one section of SSM-2400-series analog switch and the input of a bandpass filter.

The bandpass filter allows signals in the 400 to 1400Hz band to pass, while restricting all others. This frequency range was selected to best isolate voice signals, which is the desired VOX interrupt audio source. The 24dB per octave slope of the filter is quite effective in removing signals that could cause false voice detection. It was felt that providing an excellent bandpass filter would be the key to accurate voice detection. While this filter is more complicated than most VOX circuits might use, we think it provides the desired outcome. The output of the filter is sent to one section of integrated circuit operational amplifier configured as a synchronous half-wave rectifier. The output of the rectifier is a DC representation of the energy in the voice band of the input signal.

A capacitor connected to the output of the rectifier sets the VOX release time. The larger the capacitor value, the longer an absence of voice-band energy is required for the DC output to fall below the VOX threshold. The DC voltage from the rectifier is connected to one section of integrated circuit comparator. A reference voltage, created by two resistors, sets the comparator's switching threshold. A resistor from the output of the comparator to the reference input provides positive feedback, i.e., hysteresis. This adds stability to the circuit, preventing minor variations in the DC input voltage from causing rapid switching. Since the output of the comparator is an open-collector type, a pull up resistor is required. The output of the comparator is a "voice present" logic signal. It goes to the logic low state whenever a voice signal is detected. This logic signal is connected to one section of the VOX output select switch. The switch connects the VOX logic signal to the circuitry associated with the interrupt logic, program muting, and status LEDs.

The "voice present" logic signal is also connected to an inverter gate. The inverted signal controls the VOX audio analog switch, mentioned previously. The analog switch goes to the on state whenever an input audio signal is detected. The output of the analog switch is routed by the VOX output select switch to the interrupt summing bus for either channel 1 or channel 2.

Telephone Interfaces

The Model 2 contains two telephone interface circuits. Although somewhat similar, each has unique characteristics. Interface 1 is designed to receive audio from the outside world. Interface 2 can

receive audio, as well as send IFB channel 1 or 2 audio. In addition, interface 2 contains circuitry to automatically answer a ringing telephone line. Each interface contains a mode switch, allowing the interface to be set to the telephone line or standard audio mode. The telephone line mode optimizes the interface for connection to a standard loop start telephone line. This mode is sometimes referred to as "wet," a telephone company term for DC current flowing through a line. The standard audio mode optimizes the interface for connection to a circuit that does not have DC current flowing in it. This mode is sometimes referred to as "dry," a telephone company term for a line with no DC current flowing through it.

In the telephone line mode, a relay controls if the telco signal is connected to the interface. In the standard audio mode, the relay is continually energized. Both interfaces in the telephone line mode provide a telephone line termination impedance of approximately 700 ohms. In the standard audio mode, interface 1 provides a termination impedance of approximately 2200 ohms. This allows an audio source which uses an operational amplifier output to correctly interface with the Model 2. Interface 2 in the standard audio mode presents a source impedance of approximately 2200 ohms when sending channel 1 or 2 audio, and an impedance of approximately 700 ohms when receiving audio.

Now we'll discuss interface 1 specifics. The tip and ring of the telephone line enters the interface via a protection circuit consisting of a fuse, power resistor, and 360Vdc breakdown resistor (varistor). With the Model 2, transients are definitely not welcome. A sealed, bifurcated contact

relay controls the connection of the telephone line to a 600 ohm to 600 ohm coupling transformer. In series with the center taps of the transformer is a loop current detector. This circuit is quite interesting, providing both desensitization and over-current protection for the optocoupler that actually detects current flow. The output of the optocoupler is conditioned by two resistors and a capacitor to provide “debounce” of the loop current status signal. An LED, labeled LC, indicates the presence of loop current. The secondary of the transformer is connected to one section of operational amplifier which is configured as a variable gain buffer. A trim potentiometer allows the gain to be adjusted from 4 to 20dB. This processes the telephone line audio to get it to the Model 2’s nominal internal level of -10dBu. Zener diodes, connected directly across the transformer’s secondary, provide overvoltage protection for the op-amp and related circuitry.

The interface mode switch controls two functions: relay status and termination impedance. In the telephone line mode, the interface control switch located on the front panel is active, allowing the operator to control the relay. In the telephone line mode, a 1000 ohm resistor is placed across the secondary of the transformer. This, along with the op-amp’s 2200 ohm input resistor, provides the correct termination impedance for a standard telephone line. In the standard audio mode, the 1000 ohm resistor is not connected to the circuit, and the 2200 ohm input impedance of the op amp’s input resistor provides the input impedance. In the standard audio mode, the switch is disabled, the relay is held energized, and the LED labeled STD is lit.

A simple logic circuit implements the telephone interface control function. Two NAND gates form a flip-flop, the two states being on-hook and off-hook. In the telephone line mode, pressing the interface control switch to the manual off-hook position sets the flip-flop to the off-hook state, and causing the relay to energize via one gate of a power driver integrated circuit. If loop current is detected the circuit will stay in the off-hook state. If current is not detected the circuit will time out and return to the on-hook state. Pressing the interface switch to the manual hang-up position forces the circuit to the on-hook state. In the standard audio mode the logic circuitry is effectively disabled, the relay is continually energized, and the LED labeled STD is lit.

Now we’ll discuss interface 2 specifics. The tip and ring of the telephone line enters the interface via a protection circuit consisting of a fuse, power resistor, and 360Vdc breakdown resistor (varistor). In parallel with the breakdown resistor is an optical coupler-based ring voltage detection circuit. It provides a logic signal to indicate when the line is “ringing.” A sealed, bifurcated contact relay controls the connection of the telephone line to a 600 ohm to 600 ohm coupling transformer. In series with the center taps of the transformer is a loop current detector. An LED, labeled LC, indicates the presence of loop current. Zener diodes, connected directly across the transformer’s secondary, provide overvoltage protection. The secondary of the transformer is connected to the input of an operational amplifier which is configured as a variable gain buffer. A trim potentiometer allows the gain to be adjusted from 4 to 20dB.

Four sections of analog switch set the audio flow through the interface. Control signals for the analog switches are derived from the front-panel audio routing switch, along with some simple logic gates. One section of analog switch controls the output of the receive operational amplifier. It is active only when the interface is in the receive mode. This analog switch prevents channel 1 or 2 audio from “feeding back” to other Model 2 circuits when the interface is in the send mode. The other three sections of analog switch control the flow of send audio, as well as adjusting the interface termination impedance. The secondary of the transformer, via a 1000 ohm resistor, connects to one of the three remaining sections of analog switch. In the standard audio mode this switch is always in the on state, keeping the 1000 ohm resistor effectively connected across the transformer’s secondary. This resistor, along with the 2200 ohm resistor on the input of the receive op-amp, provides a 700 ohm termination impedance. In the standard audio mode this analog switch is active when the routing switch is set to send channel 1 or channel 2 audio. The two remaining analog switches control if channel 1 or channel 2 audio is connected to the send driver operational amplifier.

The interface mode switch, located on the back panel, controls two functions: relay status and termination impedance. In the telephone line mode the interface control switch is active, allowing the operator to control the relay. In the standard audio mode the switch is disabled, the relay is held energized, and the LED labeled STD is lit.

A simple logic circuit implements the telephone interface control function. Two NAND gates form a flip-flop, the two states

being on-hook and off-hook. In the telephone line mode, pressing the interface control switch to the manual off-hook position sets the flip-flop to the off-hook state, causing the relay to energize via one gate of a power driver integrated circuit. The output of the ring voltage detector can also set the flip-flop. If ringing voltage is detected for a sufficient time period the resistor/capacitor circuit on the input of the flip-flop is brought to the logic low state, and the flip-flop is set. If loop current is detected the circuit will stay in the off-hook state. If current is not detected the circuit will time out and return to the on-hook state. Pressing the interface switch to the manual hang-up position forces the circuit to the on-hook state. Notice that there is what appears to be a “bug” in this circuit when in the telephone line mode. If the interface control switch is moved to the manual off-hook position, and then moved immediately to the hang-up position, the phone line will not “hang up.” This is because approximately three seconds are required for the ringing detection capacitor to recharge after being discharged by the manual off-hook switch action. If a pause of three seconds occurs, or the interface control switch is held in the hang-up position for about three seconds, the telephone line will hang up. Normal operation will not be affected by this condition.

Access Station Interface

The Model 2 contains interface circuitry to allow up to four Model 22 Access Stations to be connected. Four types of signals are sent to and received from the access station: interrupt audio, lamp voltage, control signals, and +18Vdc power.

Two identical circuits connect access station interrupt audio into the Model 2.

Each circuit capacitive couples audio into an operational amplifier configured as an inverting unity gain buffer. The output of each op-amp is connected to one section of SSM-2400-series analog switch, part of the interrupt audio routing circuit. This analog switch produces a click-free joining of access station audio to the IFB channels.

Adjustable voltage regulator integrated circuits are used to provide power for the push button switch's status (a.k.a. tally) lamps located on the access stations. These regulators were selected because of their ability to be controlled by a logic signal, along with their inherent over-current protection.

Three logic signals are ready to be controlled by the Model 22 Access Stations: channel 1 interrupt control, channel 2 interrupt control, and monitor mute control. These CMOS-type logic signals are active low. Pull up resistors maintain a logic high, as well as providing sufficient current for the access stations to function correctly. Series resistors and zener diodes provide overvoltage protection when interfacing the nasty "outside world" signals with the Model 2's logic gates. Static "zaps" of 8000 volts shouldn't damage the Model 2—but please don't try to prove us wrong!

Filtered and regulated +18Vdc provides power for the access stations. The +18Vdc is created by a 3-terminal, integrated circuit regulator which provides over-current protection. This feature is especially important as access station cable shorts may be quite common during installation and testing.

Talent Amplifier Output

Power, IFB channel 1 audio, and IFB channel 2 audio are provided by the talent amplifier output. An integrated circuit adjustable voltage regulator provides nominal +18Vdc, which is sufficient current to power any combination of up to four Model 32 or 33 Talent Amplifiers. An operational amplifier, set for unity gain, drives the adjust pin to superimpose channel 1 audio on the DC voltage. The nominal audio level is -10dBu, with over 20dB of headroom available. The voltage regulator has inherent over-current protection so that a shorted cable will not damage the output circuitry. Another section of operational amplifier is used to drive channel 2 audio to the outside world. A resistor and capacitor in series with the output protects the op amp from a short circuit, as well as an accidental shorting of the power/channel 1 audio connection to the channel 2 connection.

Line Outputs

Each IFB channel has a balanced line-level output associated with it. The two circuits are identical. Composite IFB audio at the internal operating level of -10dBu is boosted 8dB by one section of operational amplifier. The output of the op amp is connected to a SSM-2142 differential line driver integrated circuit. This integrated circuit provides an electronically balanced, low impedance output signal. It is capable of driving high signal levels into 600 ohms or greater. Because of the nature of a differential driver, an effective 6dB boost in signal level is achieved, giving a nominal output level of +4dBu. Shorting one side of the balanced output to circuit common (pin 1 of the line output connector) will not damage the '2142. Unbalanced operation in this manner is perfectly

acceptable, as long as the short is made directly at the output connector.

Monitor Amplifier

An integrated circuit power amplifier provides 4 watts RMS of relatively low distortion audio to drive a monitor loudspeaker. A switch selects the IFB channel to be monitored. The output of the switch connects one section of SSM-2400-series analog switch which provides the click-free monitor output muting function. The output of the analog switch connects to a log taper potentiometer via a low-pass filter created using a capacitor and resistor. The wiper of the pot connects to the power amp via a DC blocking capacitor. Three resistors and a capacitor provide a half supply bias voltage. The open loop bandwidth of the power amp is limited via a capacitor in the feedback loop. The output of the amp is capacitive coupled to the output jack. A resistor/capacitor combination connected across the amp's output provides protection from oscillation.

Miscellaneous Logic Circuitry

Simple but effective logic circuitry controls the Model 2's functions. All gates, with the exception of the relay drivers, use CMOS technology for low power consumption and high reliability. Page 10 of the Model 2's schematic contains the bulk of the logic circuitry, and is fairly self-explanatory.

Meter Circuits

Two identical meter circuits monitor the audio level of the composite IFB channels. Audio signal enters a meter circuit via an operational amplifier configured as a half-wave synchronous rectifier. The resulting DC output is smoothed via a resistor/

capacitor low pass filter. This DC signal is connected to a specialized meter driver integrated circuit. It will directly control up to 10 LEDs, lighting them in 3dB steps. Five of the steps were selected for Model 2 use. The meter integrated circuit is set to operate in its bar graph mode, with the five LEDs connected in a series arrangement. This arrangement minimizes current consumption; the same current is consumed whether one LED, or all five are lit. The LED current is set to approximately 13mA by two fixed resistors.

Model 22 Access Station

General Description

The Model 22's circuitry is contained on two printed circuit boards. The bulk of it lies on the electronics board; the two push buttons lie on, you guessed it, the push button switch board. The boards are interconnected via a 12-position pin and socket arrangement. The electronics board contains power supply, interface, and audio circuitry. The Model 22 interconnects with the Model 2 Central Controller and, if present, other Model 22s via 9-pin D-subminiature female connectors. Contained on the Model 22's circuits board are two such connectors, wired in parallel. This allows "daisy-chaining" of the wiring through one unit to get to others, without requiring the use of wiring "splitters."

Power Filtering, Voltage Dividers, and Power Supply

Filtered and regulated +18Vdc is provided by the Model 2 Central Controller. A diode in series with the incoming power protects the circuitry from improper wiring. The +18V is used directly by the two four-section comparator integrated circuits,

as well as to create two reference voltages; +6V and +12V. These references are created by resistor divider circuits. The +18V also passes through a simple resistor/capacitor low pass filter. This filtered +18V, referred to as +V on the Model 22's schematic diagram, is used by the audio circuitry, as well as to create another reference voltage. This reference, aptly called VREF, is approximately half of +V and acts as an analog center voltage point—an artificial “ground.” The +18Vdc is also connected to a low-power, 3-terminal regulator. The +5Vdc filtered and regulated output voltage is used to provide power for a Studio Technologies Model 11A gooseneck electret condenser microphone.

Audio Circuitry

The Model 22 allows connection of two different types of audio sources; an electret microphone, or a line-level signal. A switch selects which input circuitry is active. In the mic position, the circuitry is configured to accept an unbalanced audio source with a nominal level of -25dBu. Connected via a current limiting resistor, +5Vdc is provided to operate the FET preamplifier in the electret microphone's cartridge. Microphone audio is capacitor coupled to two sections of low-power operational amplifier which serve as preamplifier/output driver stages. The two sections of op amp are identically configured as non-inverting amplifiers with approximately 15dB of gain, bringing the signal level to nominal -10dBu. A note to you audio purists: the selection of the LF353 was mandated strictly to address the power consumption issue, not for its less than optimal noise figure. The outputs of the op-amps are connected to two sections of analog switch.

In the line position the balanced line input circuitry is active. Our friend the SSM-2143 differential line receiver is used to interface balanced or unbalanced line-level signals. Unlike the direct coupled configuration used in the Model 2's program inputs, capacitors are used to isolate the audio signal from the Model 22's circuitry. The output of the '2143 connects to a voltage divider circuit consisting of two fixed resistors and a trim potentiometer. This “pad” reduces the line-level signal to match that of the electret microphone, which is approximately -25dBu. The trim pot provides the input level trim function, allowing a wide range of signal levels to function correctly. The unbalanced and attenuated line input signal is boosted by the preamplifier/output driver op-amps.

As mentioned two paragraphs previously, the outputs of the op amps connect to sections of analog switch. The outputs of the analog switches connect to the audio buses via capacitor/resistor combinations. The capacitors act as level shifters, moving the signal from a VREF center to a system common center point. The series resistor in the output ensures that in the event of a fault condition the op will never see less than a 2000 ohm load. It also protects the analog switch from transients or shorts to +18Vdc in the interconnecting cables. The analog switches are held in the off condition unless the access station is initiating an interrupt. At that time audio, via the analog switches, is placed on the appropriate audio bus(es).

Logic Circuitry

All logic functions are performed using sections of integrated circuit comparator, along with two “spare” analog switches. Credit Mitch, the consulting engineer, for

continuing to prove that comparators are about the handiest “building block” available! The comparators perform three major functions. The first function prevents an access station from initiating an interrupt on a channel that is already in the interrupt state. This allows only one access station at a time to interrupt a channel. This function is operationally helpful, as well as being required by the audio bus arrangement. If, for example, two access stations connect to the bus at once, the audio level of the two signals would each drop by 6dB. This is due to the fact that the outputs would load each other, creating a voltage divider. The operating state of the interrupt channels is determined by monitoring the status lamp voltages. A lamp voltage is nominally 10V when an interrupt channel is idle, 14.5V when active. The 12V reference is used by the comparators as the lamp voltage “slicing” level. Another section of comparator is used to “mask” the lamp signal when the access station has initiated the interrupt. This prevents an oscillation condition—can you figure out what it is?

The second function the comparators perform is to activate the interrupt (talk) buses. When the access station’s interrupt logic lines go to the interrupt active state the comparator outputs sink current, pulling the interrupt buses to the low state. The buses are normally high, and get pulled low when interrupt is required.

The third comparator function, if configured upon installation using a slide switch, causes the Model 2’s monitor output to mute whenever the access station is initiating an interrupt. This is an important feature, preventing feedback if the access station is located in close proximity to the monitor loudspeaker. Two sections of

comparator monitor the internal interrupt active logic signals. The 6V reference is used as the slicing level. The outputs of the comparators are connected in parallel, allowing current sinking whenever one or both of the channels are active. The comparators have open collector outputs, thus allowing the direct parallel connection—pretty handy, huh!) The paralleled comparator outputs are connected, via the configuration switch, to the monitor mute bus. The bus is normally high, and gets pulled low by the comparators when monitor muting is required.

Two analog switches perform a dual role, provide voltage level shifting, and implementing a delay function. The switches convert the access station’s interrupt active logic signal, which is referenced to system common, to a signal referenced to VREF. The analog switches which connect audio to the buses need VREF as their reference. A combination of a diode, resistor, and capacitor form a delay-on-turn off function. This allows the SSM-2400-series analog switches on the Model 2 to quietly disconnect the access station audio buses from the interrupt channel prior to the access station releasing its connection to the bus. This prevents a nice loud click from reaching the interrupt output. Only a delay on turn off is implemented. A fast off-to-on turn on is required, placing the access station audio on the bus prior to the analog switch on the Model 2 quietly ramping to the on state.

Model 32 Talent Amplifier

General Description

The Model 32 Talent Amplifier is a self-contained module which allows headphones or ear pieces to be driven with

IFB channel 1 or 2 audio from a Model 2 Central Controller. The unit contains circuitry to extract DC power from the three conductors that carry power and two channels of audio. Along with a power amplifier integrated circuit, the unit contains a channel select switch, power LED, and level control. The Model 32 contains two 3-pin XLR-type connectors, one male and one female. The female connector is intended to interconnect with the Model 2's talent amplifier output. The male connector is intended to facilitate connection of additional Model 32 or Model 33s Talent Amplifiers using standard microphone-type cables.

The Model 32's circuitry is contained on two printed circuit boards, which are interconnected via a 5-conductor flexible jumper cable. All active circuitry lies on the electronics board; the connectors lie on the connector board—no surprises here!

Power Supply

The Model 2 Central Controller provides +18Vdc modulated with channel 1 audio on pin 2 of the XLR connector. Channel 2 audio is provided on pin 3, with pin 1 supplying common. From the Model 2, the nominal audio levels are -10dBu. A 3-terminal adjustable integrated circuit voltage regulator is configured to provide +10V, nominal, from the incoming +18V that is modulated with channel 1 audio. The important characteristic about this circuit is its constant input impedance characteristic. The input impedance is fixed at a moderately high value, approximately 500 ohms, and does not vary appreciably with load. This is important so that the channel 1 audio signal is not significantly attenuated, nor distorted by normal fluctuations in the power draw. An

LED indicator light provides indication that +10V power is present.

Power Amplifier

An industry-standard (for good reason) LM386N-1 power amplifier integrated circuit is used to drive the audio output. Signal enters the amplifier circuit via a switch that selects the input source, either IFB channel 1 or 2. The signals are coupled to the switch via coupling capacitors, providing DC blocking, and preventing audio "clicks" when switching between channels. The output of the switch is connected, via a low pass filter, to a log taper audio potentiometer. This pot allows user adjustment of the output level. A resistor in series with the potentiometer prevents the output level from being completely shut off, a useful broadcast feature. A low pass filter on the output of the amplifier helps to provide stability. The amplifier's output is capacitor coupled, via a series resistor, to the output connector. The capacitor changes the audio output signal from being biased at approximately +5V, to being biased at signal common. The series resistor limits the output current in the event of a shorted output connecting cable.

Model 33 Talent Amplifier

General Description

The Model 33 Talent Amplifier is a self-contained module which allows headphones or ear pieces to be driven with IFB channel 1 or 2 audio from a Model 2 Central Controller. The unit contains circuitry to extract DC power from the three conductors that carry power and two channels of audio. Along with a power amplifier integrated circuit, the unit contains a channel select switch, power LED, and level control. The Model 33 contains two 3-pin XLR-type connector, one male and one

female. The female connector is intended to interconnect with the Model 2's talent amplifier output. The male connector is intended to facilitate connection of additional Model 33 or Model 32s using standard microphone-type cables.

The Model 33's circuitry is contained on two printed circuit boards, which are interconnected via a 5-conductor flexible jumper cable. All active circuitry lies on the electronics board; the connectors lie on the connector board—no surprises here!

Power Supply

The Model 2 Central Controller provides +18Vdc modulated with channel 1 audio on pin 2 of the XLR connector. Channel 2 audio is provided on pin 3, with pin 1 supplying common. From the Model 2, the nominal audio levels are -10dBu. A 3-terminal adjustable integrated circuit voltage regulator is configured to provide +10V, nominal, from the incoming +18V that is modulated with channel 1 audio. The important characteristic about this circuit is its constant input impedance characteristic. The input impedance is fixed at a moderately high value, approximately 500 ohms, and does not vary appreciably with load. This is important so that the channel 1 audio signal is not significantly attenuated, nor distorted by normal fluctuations in the power draw. An LED indicator light provides indication that +10V power is present. A zener diode, in series with the LED, is used to generate a 5.6V reference for the circuitry.

Mixer/Output Amplifier

IFB channel 1 and 2 audio is capacitor-coupled to two audio-taper potentiometers. Resistors in series with the pots ensures that the audio level can never be fully turned "off." The output signals from

the pots connect to an NE55320-type operational amplifier that is configured as a combining amplifier. The faithful '5532 is used both to mix the audio sources, as well as to drive the audio output. Signal enters the op-amp via a switch that selects which of the two input sources are active. Note that the switch actually selects one source by muting the other! The op-amp's output is capacitor coupled, via a series resistor, to the output connector. The capacitor serves as a DC blocking function, changing the output so as to be referenced to signal common. The series resistor helps the op-amp maintain stability, as well as providing protection in the event of a shorted output connecting cable.

Troubleshooting



Troubleshooting the Model 2 and related components is to be performed only by a qualified technician. Operating the Model 2 with the cover removed exposes you to hazardous voltages.

Detailed block diagrams, located at the end of this guide, and schematic diagrams, located in the separate schematic packet, are provided for assistance during maintenance and repair. Understanding the block diagrams will lead to much better understanding of the individual circuits and how they work together (or, in case of trouble, how they don't work together!)

Model 2 Central Controller

The Model 2 consists of many relatively simple circuits. Detailed troubleshooting procedures are difficult to describe because there are few specific circuits that

are prone to failure. The following paragraphs may give a few helpful hints if problems do arise. In all cases, you are welcome to contact Studio Technologies for technical support.

Wiring Errors

The Model 2 provides +18Vdc for use by the Model 22 Access Stations. Up to four access stations can be connected, drawing a total maximum of 100mA nominal from the +18Vdc supply. The +18Vdc is produced by a 3-terminal regulator. Should the +18Vdc get shorted to common up to one amp of current may flow through the regulator. By design, the +18Vdc regulator does not use a heat sink. This helps the device heat faster under excessive current flow, allowing the internal overpower protection to shut down the regulator. During the short circuit condition the power transformer may vibrate under the strain of excessive current. Be aware that the monitor output power amplifier shares this transformer. Should the +18Vdc be “dead shorted” the monitor performance will also suffer.

The talent amplifier output also uses an adjustable 3-terminal regulator to create +18Vdc modulated with channel 1 audio. In this case, the design required the use of a heat sink. Like the +18Vdc supply for the access station, a shorted talent amplifier output will result in excessive currents, followed by thermal shutdown. Removing the short and allowing time for the device to cool will restore operation.

Power Supplies

Should problems occur with the Model 2, the power supplies are the first thing to examine. The unit contains three independent supplies, each with transformer, bridge rectifier, filtering, etc. Use the test

points to ensure that the correct voltages are present. Be aware that the +34V UNREG and +25V UNREG can vary greatly from the nominal value.

There are two very common reasons why a power “rail” can go down: defective electrolytic capacitor and a shorted power bus. With time, over-temperature, etc., an electrolytic capacitor can fail. The caps used in the Model 2 are heavily overrated for normal use, but still could fail. Use an oscilloscope to examine the unregulated voltage points. Check for excessive “ripple.” The 3-terminal regulators are quite reliable and are not a weak link. A shorted integrated circuit, such as a TL072, can draw enough current to cause a regulator to go into the thermal shut-down mode. Eliminate the short, wait a minute or two, and the supply should come up again.

Audio Circuitry

The Model 2 uses straightforward audio circuitry throughout. Normal “follow the audio flow” troubleshooting techniques should be used. A digital multimeter, oscilloscope, signal generator, and audio VTVM should be all that is required.

Telephone Interfaces

Each telephone interface contains a protection fuse. Each fuse is electrically connected between the ring lead of the modular jack and the transient suppressor (varistor). The fuse will open (blow) should the interface be exposed to extremely large current flow. These currents can occur because of a “mega” lightning hit, or because of a high voltage power line “cross.” Should a telephone interface fail to function be certain to check the fuse first. Perform any repairs only after the Model 2 has been disconnected from

mains power and the telephone lines.
Replace a blown fuse only with the correct
type: 0.5A, 250V, 2AG, slow blow.

Model 22, Model 32, & Model 33

The Model 22 Access Station, the Model 32 Talent Amplifier, and the Model 33 Talent Amplifier all have fairly simple circuitry. A careful review of the block diagrams, located at the end of this guide, and schematic diagrams, located in the separate schematic packet, should allow rapid problem solving. All share the condition that all signals, including power, audio, and logic, begin and/or end with the Model 2 Central Controller.

The first thing to determine is that the wiring linking the units together is correct. Ensure that the Model 22 is getting +18Vdc for operation. The Model 32 and Model 33 use +18Vdc modulated with channel 1 audio. Use an oscilloscope to check for both the DC voltage, and the superimposed audio signal.

Specifications

Model 2 Central Controller

Mounting:

One space in a standard 19-inch (48.3cm) rack

Back Mounting Locations:

Provision made for attaching customer-fabricated back brackets. Use four (two per side) 8-32 machine screws to attach brackets to the sides of the Model 2 chassis.

Mains Power Requirements:

120 or 220/240V, $\pm 10\%$, internally configured, 50/60Hz, 10 watts

Mains Connector Type:

3-conductor IEC-type

Mains Fusing: 1

Type: 5 x 20mm, fast-acting

Rating: 0.5A for 120V mains power, 0.25A for 220/240V

IFB Channels: 2

Channel Features: 6-position program select switch, program level control, status LEDs, 5-segment LED level meter

Audio Switching: solid state, ramping "clickless" integrated circuit analog switches

General System Audio Specifications:

(Measurements taken from program input to line output)

Distortion (THD+N): 0.03%, measured at 1kHz

Frequency Response: better than ± 0.5 dB, 20Hz-20kHz

S/N Ratio: 67dB

Program Inputs: 4

Connector: 3-pin XLR-type, female, pin 2 high

Type: electronically balanced, direct coupled

Input Impedance: 24k ohms

Input Compatibility: can be connected to balanced or unbalanced signals

Common Mode Rejection: 90dB @ DC and 60Hz, 85dB @ 20kHz, 60dB @ 400kHz (typical)

Nominal Input Level: +4dBu

Input Trim Control: allows adjustment of input sensitivity over a ± 8 dB range, nominal

Auxiliary Audio Input:

Application: used with voice operated (VOX) interrupt

Connector: 3-pin XLR-type, female, pin 2 high

Type: electronically balanced, direct coupled

Input Impedance: 24k ohms

Common Mode Rejection: 90dB @ DC and 60Hz, 85dB @ 20kHz, 60dB @ 400kHz (typical)

Nominal Input Level: +4dBu

Input Trim Control: allows adjustment of input sensitivity over a ± 8 dB range, nominal

Talent Amplifier Output:

Application: intended to provide power and audio signals for any combination of up to four Model 32 or Model 33 Talent Amplifiers

Connector Type: 3-pin XLR-type, male, pin 1 common, pin 2 +18Vdc modulated with channel 1 audio, pin 3 channel 2 audio

Audio Output Levels: -10dBu, nominal

Maximum DC Output Current: approximately 500mA

Line Outputs: 2, one per IFB channel

Type: electronically balanced, direct coupled, intended to drive loads of 600 ohms or greater, can be connected to balanced or unbalanced loads

Nominal Output Level: +4dBu

Maximum Output Level Before Clipping: +24dBu into 600 ohms, balanced

Output Impedance: 50 ohms

Voice Operated (VOX) Interrupt Function:

Input: auxiliary audio, receive audio telephone interface 1, or receive audio telephone interface 2, selectable

Output: IFB channel 1 or IFB channel 2, selectable

Detection Bandpass: bandpass filter with 3dB points @ 400 and 1400Hz

Detection Threshold: 18dB below nominal input level over 400-1400Hz band

Release Threshold: 26dB below nominal input level over 400-1400Hz band

Detect Time for Valid Signal: less than 1mSec

Release Time after Valid Signal: 350mSec

Telephone Interface:

Operating Modes: telephone line or standard audio signal, switch selectable

Definition of Telephone Line: intended for connection to standard loop start telephone lines

Definition of Standard Audio Signal: intended for connection to balanced or unbalanced audio signals (no DC loop current)

Impedance (Telephone Line Mode): 700 ohms, DC off-hook resistance 200 ohms

Impedance (Standard Audio Mode): 700 ohms

Telephone Line Requirements (Telephone Line Mode): 2-wire, loop start, 10mA loop current minimum

Interconnection: mates with standard USOC RJ11 jack using standard 6-position modular cable

Interface Protection Fuse: 0.5A, 250V, 2AG, slow blow, solder-in pigtail type, Littelfuse 230 or equivalent

Disconnect (Telephone Line Mode): manual using front-panel switch or automatically after detection of 250mSec, nominal, break in loop current

Interface Control (Telephone Line Mode): switch on front panel allows manual off-hook and manual hang-up functions

Receive Audio Level: -15dBu, nominal

Receive Audio Adjustment Range: ±8dB

Indicator Lights: 2, one yellow LED indicates operation in standard audio mode, one red LED indicates loop current flowing through interface

Telephone Interface 2:

Operating Modes: telephone line or standard audio signal, switch selectable

Impedance (Telephone Line Mode): 700 ohms, DC off-hook resistance 200 ohms

Impedance (Standard Audio Mode): 700 ohms, receive mode, 2200 ohms send mode

Telephone Line Requirements (Telephone Line Mode): 2-wire, loop start, 10mA loop current minimum

Ring Detection (Telephone Line Mode): 40 to 150V RMS, 18-68Hz, ringer equivalence 0.93

Number of Rings to Answer (Telephone Line Mode): 1, or a fraction of one ring

Interconnection: mates with standard USOC RJ11 jack using standard 6-position modular cable

Interface Protection Fuse: 0.5A, 250V, 2AG, slow blow, solder-in pigtail type, Littelfuse 230 or equivalent

Disconnect (Telephone Line Mode): manual using front-panel switch or automatically after detection of 250mSec, nominal, break in loop current

Interface Control (Telephone Line Mode): switch on front panel allows manual off hook and manual hang-up functions

Audio Routing Control: switch on front panel allows interface to receive audio, send channel 1 audio, or send channel 2 audio

Receive Audio Level: -15dBu, nominal

Receive Audio Adjustment Range: ±8dB

Send Audio Level: -6dBu, nominal

Indicator Lights: 2, one yellow LED indicates operation in standard audio mode, one red LED indicates loop current flowing through interface

Access Station Interface:

Connector Type: 9-pin D-type, female

Application: provides power, audio, control inputs, and status lamps outputs for up to four Model 22 Access Stations

Power: +18Vdc, filtered and regulated, current limited

Audio Inputs: one input per IFB channel, unbalanced, capacitor coupled, 100k ohm input impedance, -10dBu nominal audio level

Control Signals: 3, one per IFB channel, one for monitor mute function, all lines active low

Status Lamp Outputs: one per IFB channel, 9.6Vdc channel inactive, 14.5Vdc channel active, nominal, current limited

Monitor Output:

Application: designed to drive loads of 8 ohms or greater

Connector Type: ¼-inch 2-conductor phone jack

Output Power: 4W RMS into 8 ohms, measured @ 1kHz, 1% THD+Noise

Internal Microphone:

Type: electret condenser

Frequency Response: 3dB low frequency rolloff @ 105Hz

Interrupt Audio Compressor/Limiter:

Number of Circuits: 2, one per IFB channel

Type: dual slope

Ratio in Compression Area: 4 to 1

Ratio in Limiting Area: infinity

Dimensions (Overall):

19.00 inches wide (48.3cm)

1.72 inches high (4.4cm)

11.4 inches deep—overall (29.0cm)

Weight:

10.4 pounds (4.7kg)

Model 22 Access Station

Mounting:

Rack mounted using Model 25A 19-inch Rack Adapter. Panel mounted using Model 28A Panel Adapter. Custom mounting easily accomplished.

Power Requirements:

+18Vdc, 25mA maximum, provided by Model 2 Central Controller

Interconnection:

Contains two 9-pin D-subminiature connectors (female). One connector intended to link Model 22 to Model 2 Central Controller. The second connector, wired in parallel with the first, is designed to allow “loop through” installation for connection to additional Model 22(s).

Push Button Switches: 2

Type: backlit, momentary, EAO 99-series

Lamp Type: incandescent, T-1, bi-pin, 18V, 26mA, 0.5W Equivalent to EAO Switch Corp. 11-903-2, Wamco 0L1100BPE, Lampronics AS25-8

Audio Inputs:

Electret microphone or line level, switch selectable

Microphone Input:

Compatibility: designed only for use with 2-wire gooseneck electret microphone (2 wires + shield). Intended input level –25dBu nominal. Model 11A gooseneck microphone available from Studio Technologies.

Microphone Power: +5Vdc, current limited. Applied to microphone “high” lead.

Connector: three terminals on screw terminal strip

Line Input:

Type: electronically balanced, capacitor coupled, compatible with balanced or unbalanced audio signals

Input Impedance: 24k ohms

Common Mode Rejection: 100dB @ DC and 60Hz, 70dB @ 20kHz, 62dB @ 40kHz (typical)

Input Level: –15 to +10dBu, input level adjustable via trim potentiometer

Connector: two screw terminals on screw terminal strip

Dimensions (Overall):

6.4 inches wide (16.3cm)

1.6 inches high (4.1cm)

5.2 inches deep (13.2cm)

Weight:

0.8 pounds (0.4kg)

Model 25A 19-inch Rack Adapter

Application:

Intended for use with Model 22 Access Station and Model 11A gooseneck microphone

Dimensions (with Model 22 attached):

19.00 inches wide (48.3cm)

1.72 inches high (4.4cm)

5.2 inches deep—overall (13.2cm)

Mounting:

One space in a standard 19-inch (48.3cm) rack

Weight (with Model 22 attached):

1.6 pounds (0.7kg)

Model 28A Panel Adapter

Mounting:

Designed to be mounted in a panel opening. Recommended opening size 6.5 inches wide (16.5cm), 1.7 inches high (4.3cm), 6.5 inches minimum depth (16.5cm)

Application:

Intended for use with Model 22 Access Station and Model 11A gooseneck microphone

Dimensions (with Model 22 attached):

8.0 inches wide (20.3cm)
2.75 inches high (7.0cm)
5.2 inches deep—overall (13.2cm)

Weight (with Model 22 attached):

1.3 pounds (0.6kg)

Model 32 Talent Amplifier

Mounting:

Intended for portable applications. Contains integral belt clip. Optional Model 36 Mounting Adapter allows Model 32 to be permanently mounted.

Primary Application:

Intended for use with Model 2 Central Controller

Indicator Light:

Red LED indicates operation of internal power supply

Power/Audio Input:

Connector: 3-terminal XLR-type female

Signals: pin 1 common, pin 2 +18Vdc modulated with channel 1 audio, pin 3 channel 2 audio

Audio Levels: -10dBu nominal

Power Requirements: 12 to 35Vdc, 20mA normal operation, 110mA worst case (shorted headphone output)

Loop Through Connector:

Type: 3-terminal XLR-type male, connected in parallel with input connector

Purpose: Intended to be used to connect multiple talent amplifiers in a “loop through” arrangement

Audio Amplifier:

Output Connector: ¼-inch 2-conductor (monaural) phone jack

Load: intended for connection to headphones or ear pieces with impedance of 8 ohms or greater

Source: IFB channel 1 or channel 2, switch selectable by user

Output Level: user adjustable via log taper potentiometer

Maximum Output Power: 170mW into 8 ohms, @ 1% THD+Noise, 400Hz

Distortion (THD+N): less than 0.15%, measured at 400Hz, 100mW output power into 8 ohms

Frequency Response: optimized for voice response and high frequency rejection. Low frequency rolled off, 3dB down at 120Hz. High frequency rolled off, 1.7dB down at 20kHz

Dimensions (Overall):

3.6 inches wide (9.1cm)
4.8 inches high (12.2cm)
1.9 inches deep (4.8cm)

Weight:

0.6 pounds (0.3kg)

Model 33 Talent Amplifier

Mounting:

Intended for portable applications. Contains integral belt clip. Optional Model 36 Mounting Adapter allows Model 33 to be permanently mounted.

Primary Application:

Intended for use with Model 2 Central Controller

Indicator Light:

Red LED indicates operation of internal power supply

Power/Audio Input:

Connector: 3-terminal XLR-type female

Signals: pin 1 common, pin 2 +18Vdc modulated with channel 1 audio, pin 3 channel 2 audio

Audio Levels: -10dBu nominal

Power Requirements: 12 to 35Vdc, 21mA normal operation, 34mA worst case (shorted headphone output)

Loop Through Connector:

Type: 3-terminal XLR-type male, connected in parallel with input connector

Purpose: Intended to be used to connect multiple talent amplifiers in a "loop through" arrangement

Audio Amplifier:

Output Connector: ¼-inch 2-conductor (monaural) phone jack

Load: intended for connection to headphones or ear pieces with impedance of 150 ohms or greater

Source: IFB channel 1 and/or channel 2, switch selectable by user

Output Level: user adjustable via two log taper potentiometers

Maximum Output Power: 35mW into 150 ohms, @ 1% THD+Noise, 400Hz

Distortion (THD+N): less than 0.15%, measured at 400Hz, 32mW output power into 150 ohms

Frequency Response: optimized for voice response and high frequency rejection.

Dimensions (Overall):

3.6 inches wide (9.1cm)

4.8 inches high (12.2cm)

1.9 inches deep (4.8cm)

Weight:

0.6 pounds (0.3kg)

Model 36 Mounting Adapter

Application:

Intended for use with Model 32 and Model 33 Talent Amplifiers

Dimensions (overall, with Model 32 or 33 attached):

5.4 inches wide (13.7cm)

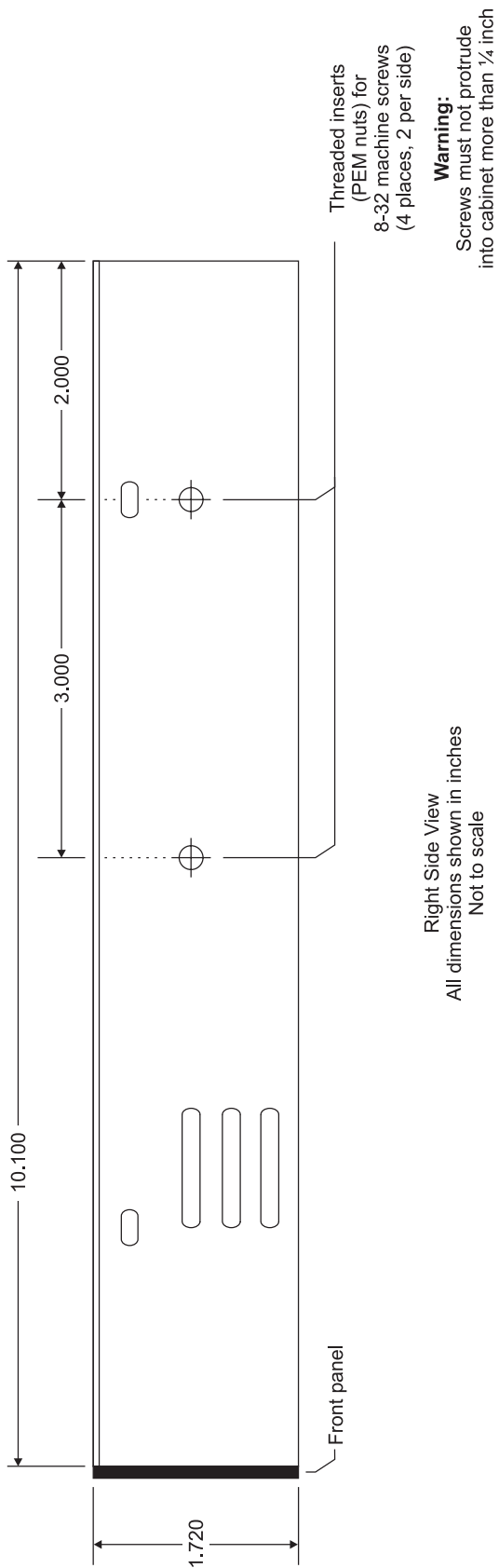
4.8 inches high (12.2cm)

2.0 inches deep (5.1cm)

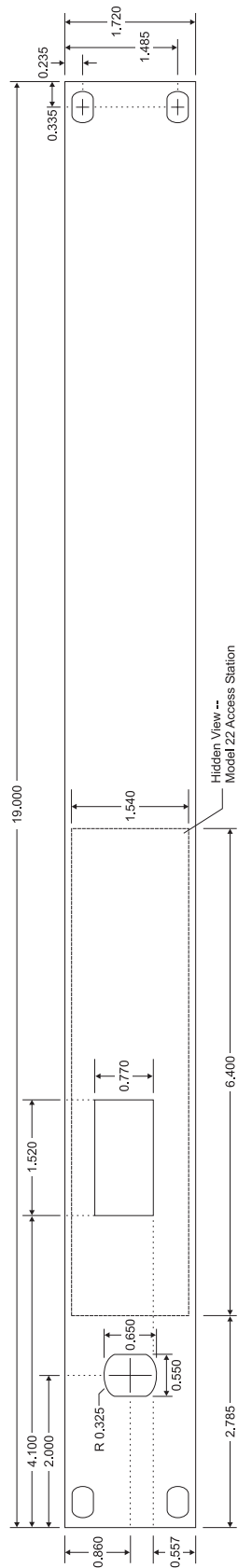
Specifications and information contained in this User Guide subject to change without notice.

This page intentionally left blank.

**Figure 1. IFB Plus Series Model 2 Central Controller Rear Bracket Mounting Hole Location
(for fabricating customer-provided brackets)**

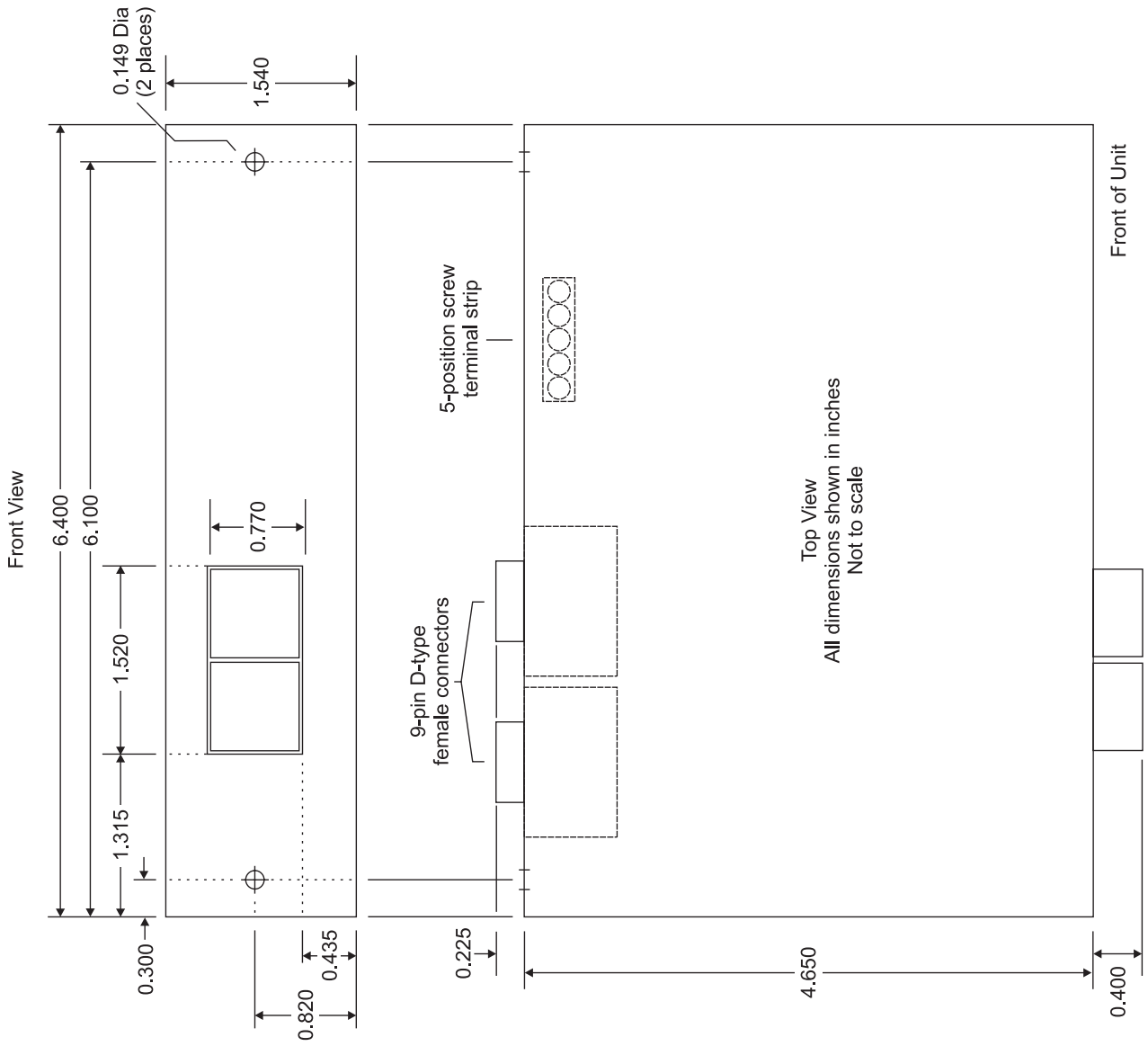


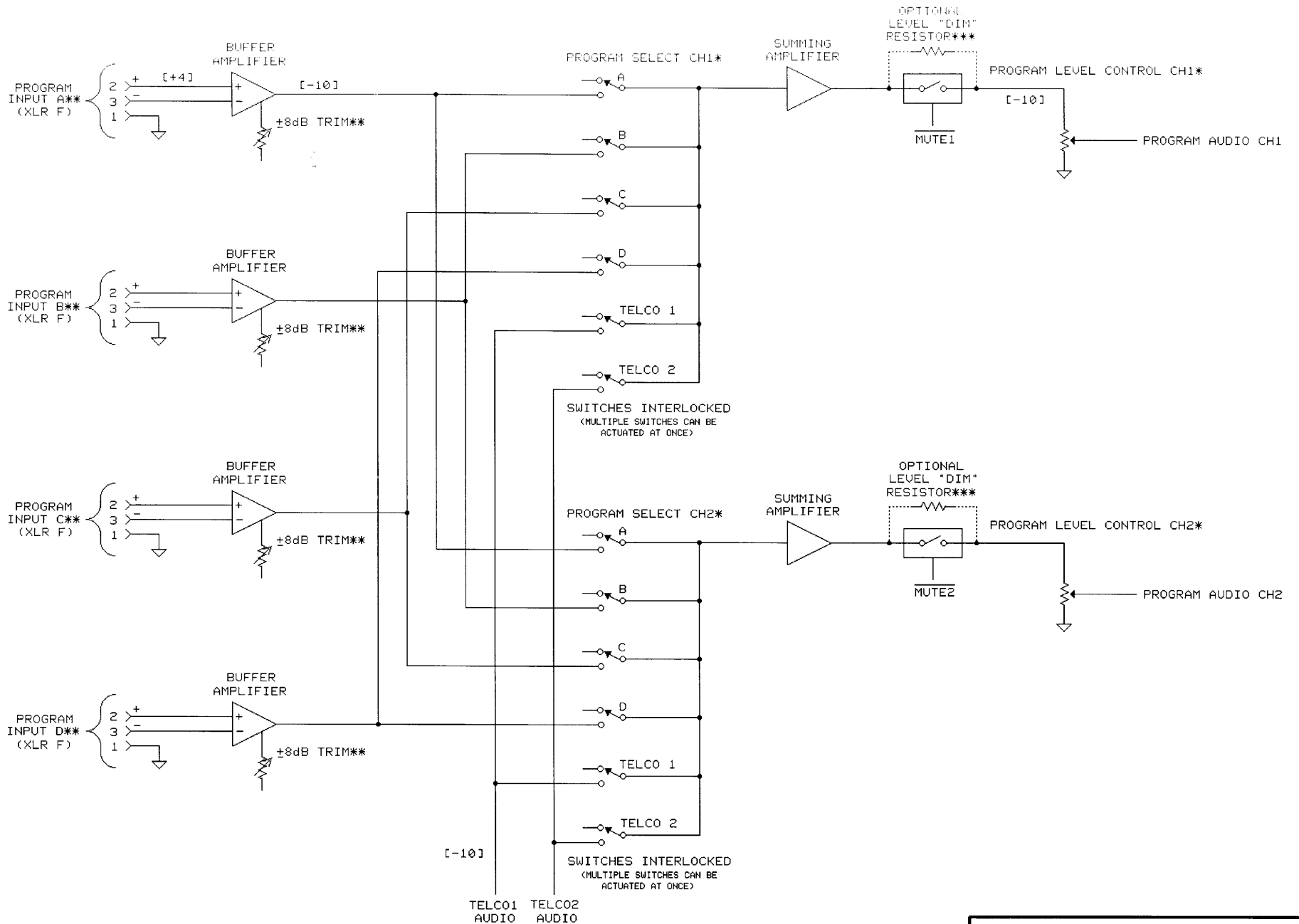
**Figure 2. IFB Plus Series Model 25A 19-Inch Rack Adapter
(used with Model 22 Access Station and Model 11A Gooseneck Microphone)**



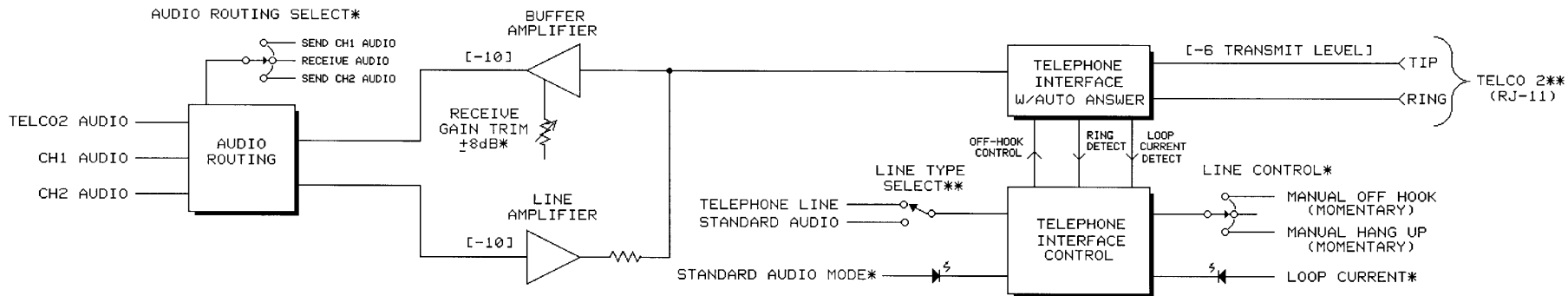
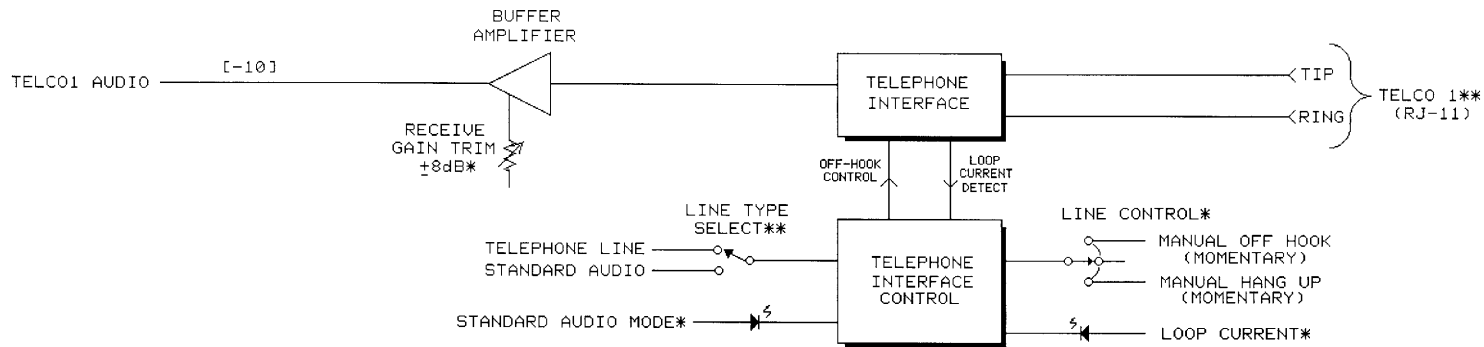
Front View
All dimensions shown in inches
Not to scale

Figure 4. IFB Plus Series Model 22 Access Station Overall Dimensions





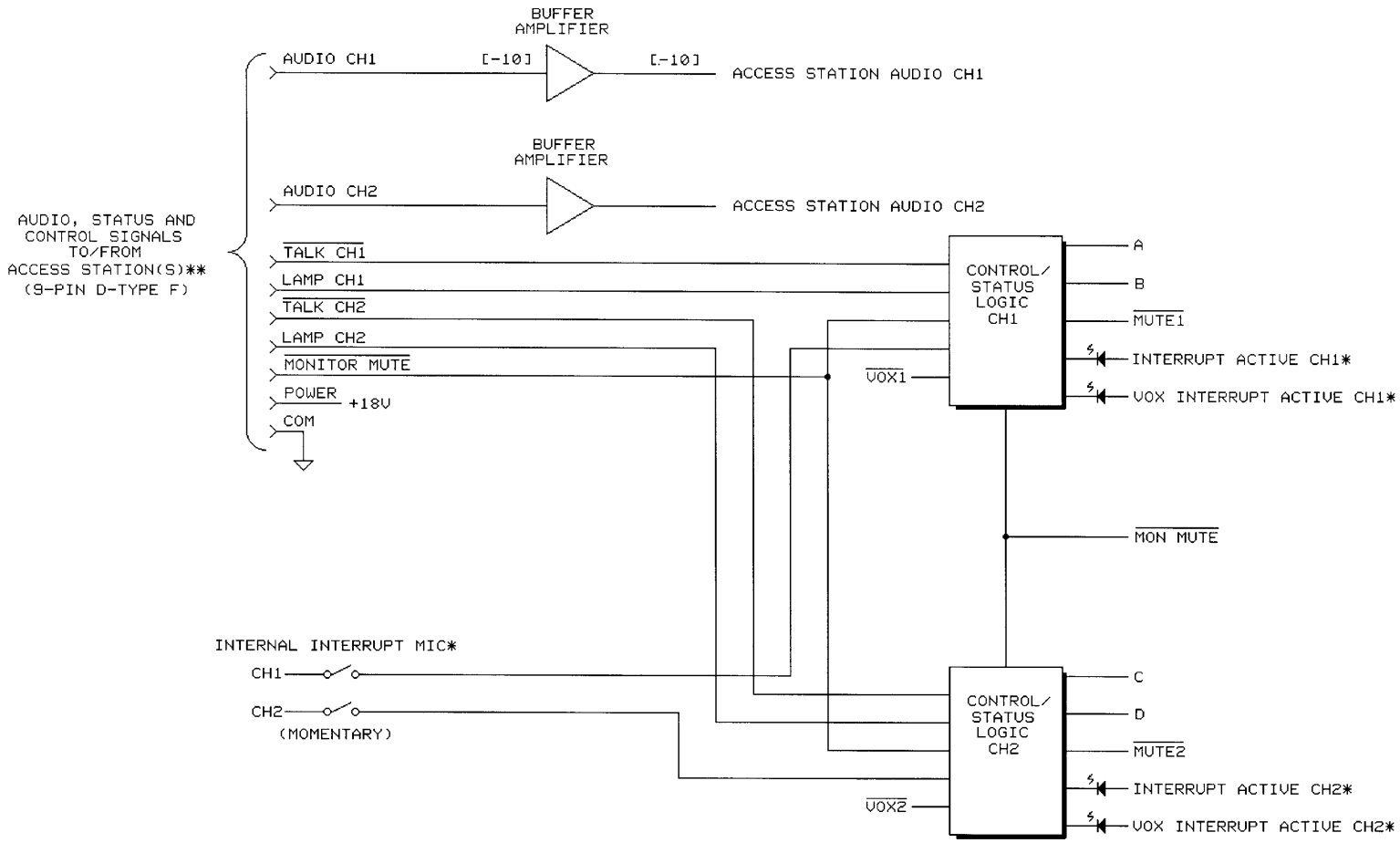
* LOCATED ON FRONT PANEL
 ** LOCATED ON REAR PANEL
 *** FACTORY CONFIGURATION MUTES AUDIO DURING INTERRUPT. ADD RESISTORS TO DROP, RATHER THAN FULLY MUTE PROGRAM AUDIO.
 [NOMINAL LEVEL IN dBu]



STUDIO TECHNOLOGIES, INC.

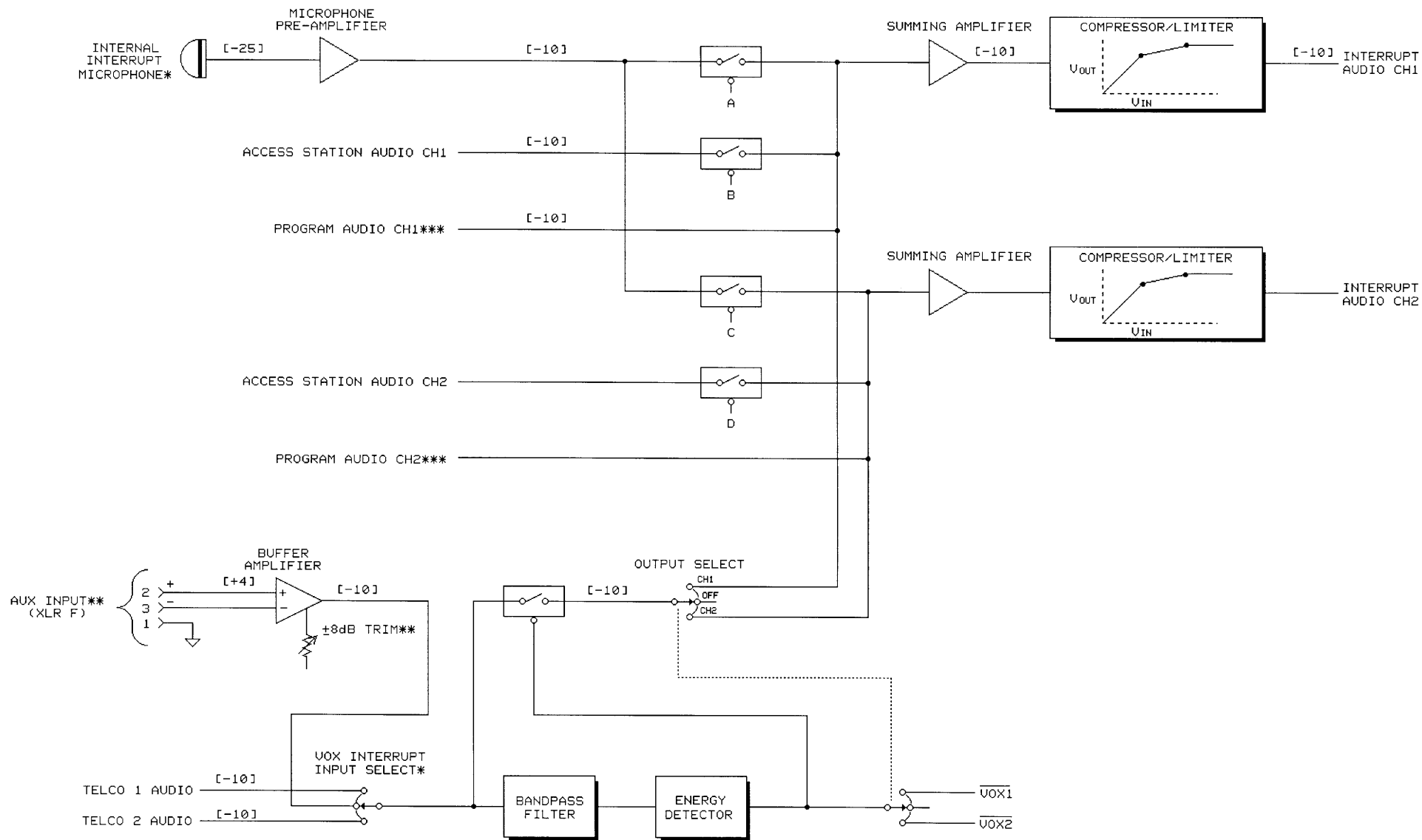
IFB PLUS SERIES
MODEL 2 CENTRAL CONTROLLER
BLOCK DIAGRAM

* LOCATED ON FRONT PANEL
** LOCATED ON REAR PANEL
[NOMINAL LEVEL IN dBu]



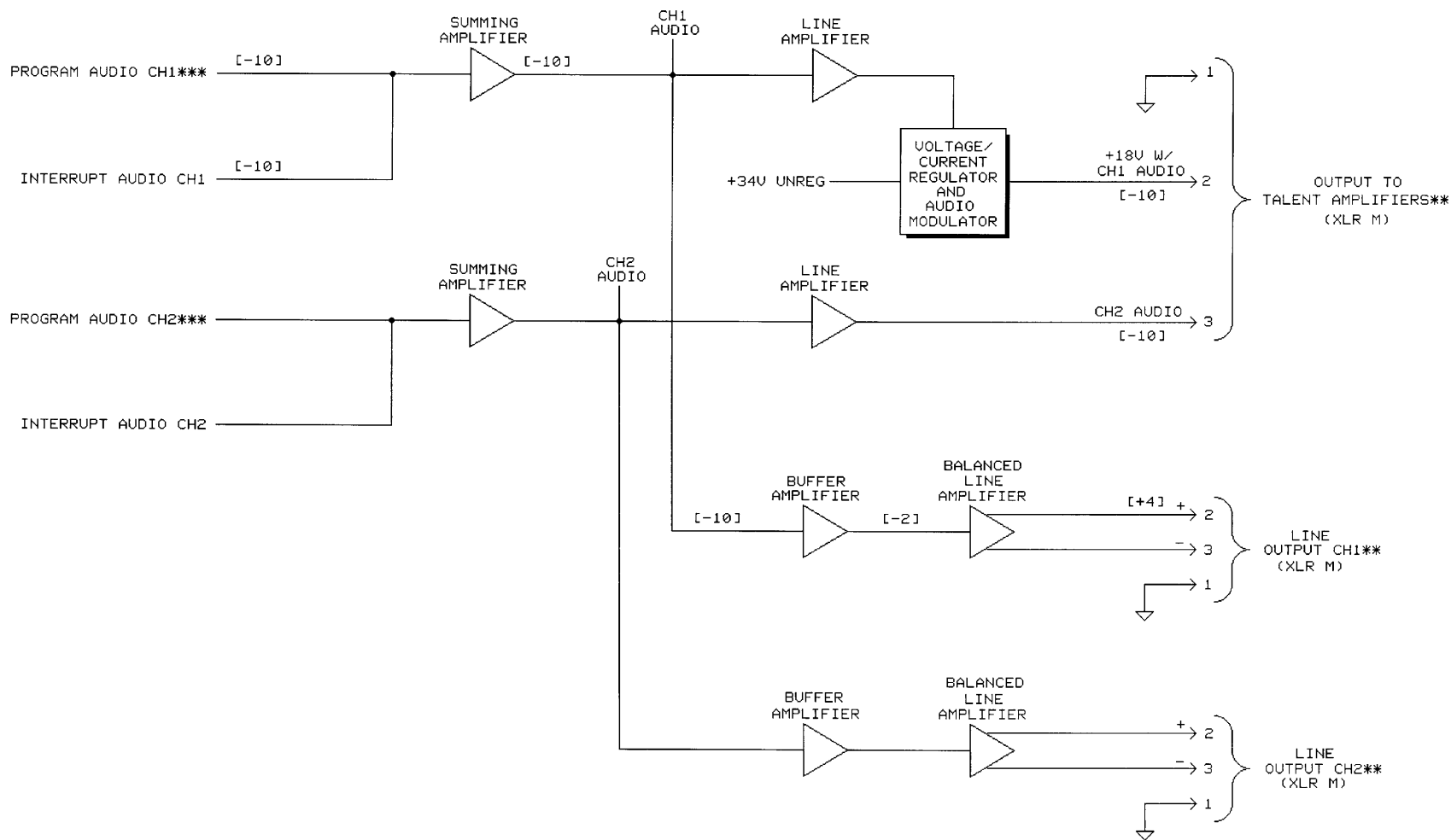
STUDIO TECHNOLOGIES, INC.
 IFB PLUS SERIES
 MODEL 2 CENTRAL CONTROLLER
 BLOCK DIAGRAM

* LOCATED ON FRONT PANEL
 ** LOCATED ON REAR PANEL
 [NOMINAL LEVEL IN dBu]



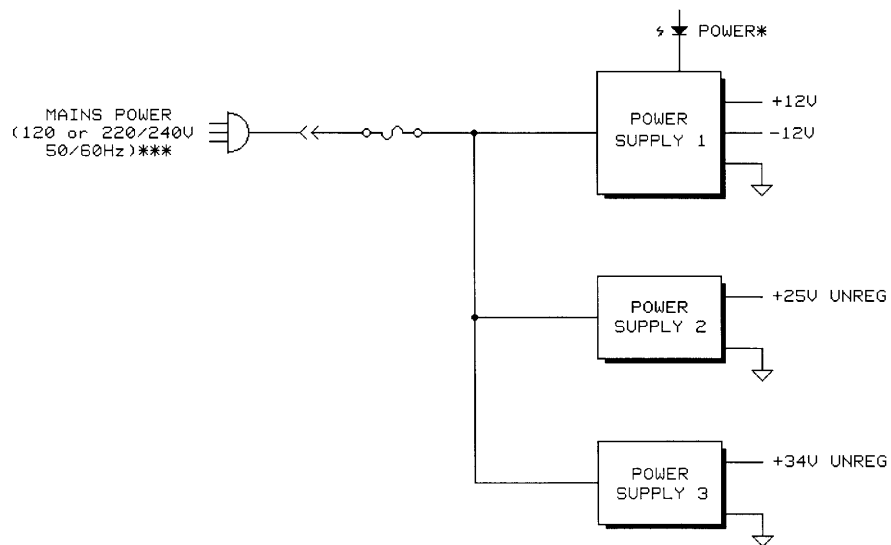
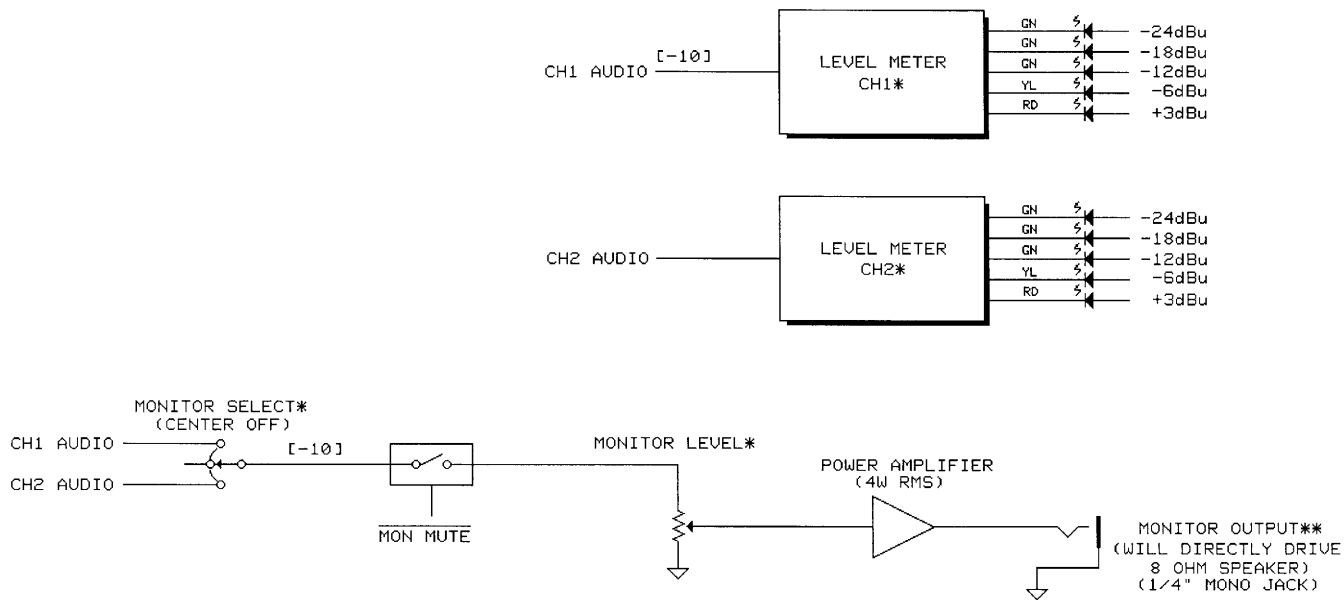
* LOCATED ON FRONT PANEL
 ** LOCATED ON REAR PANEL
 *** OPTIONAL CONFIGURATION ALLOWS PROGRAM AUDIO TO BE PROCESSED BY COMPRESSOR/LIMITER.
 [NOMINAL LEVEL IN dBu]

STUDIO TECHNOLOGIES, INC.
 IFB PLUS SERIES
 MODEL 2 CENTRAL CONTROLLER
 BLOCK DIAGRAM

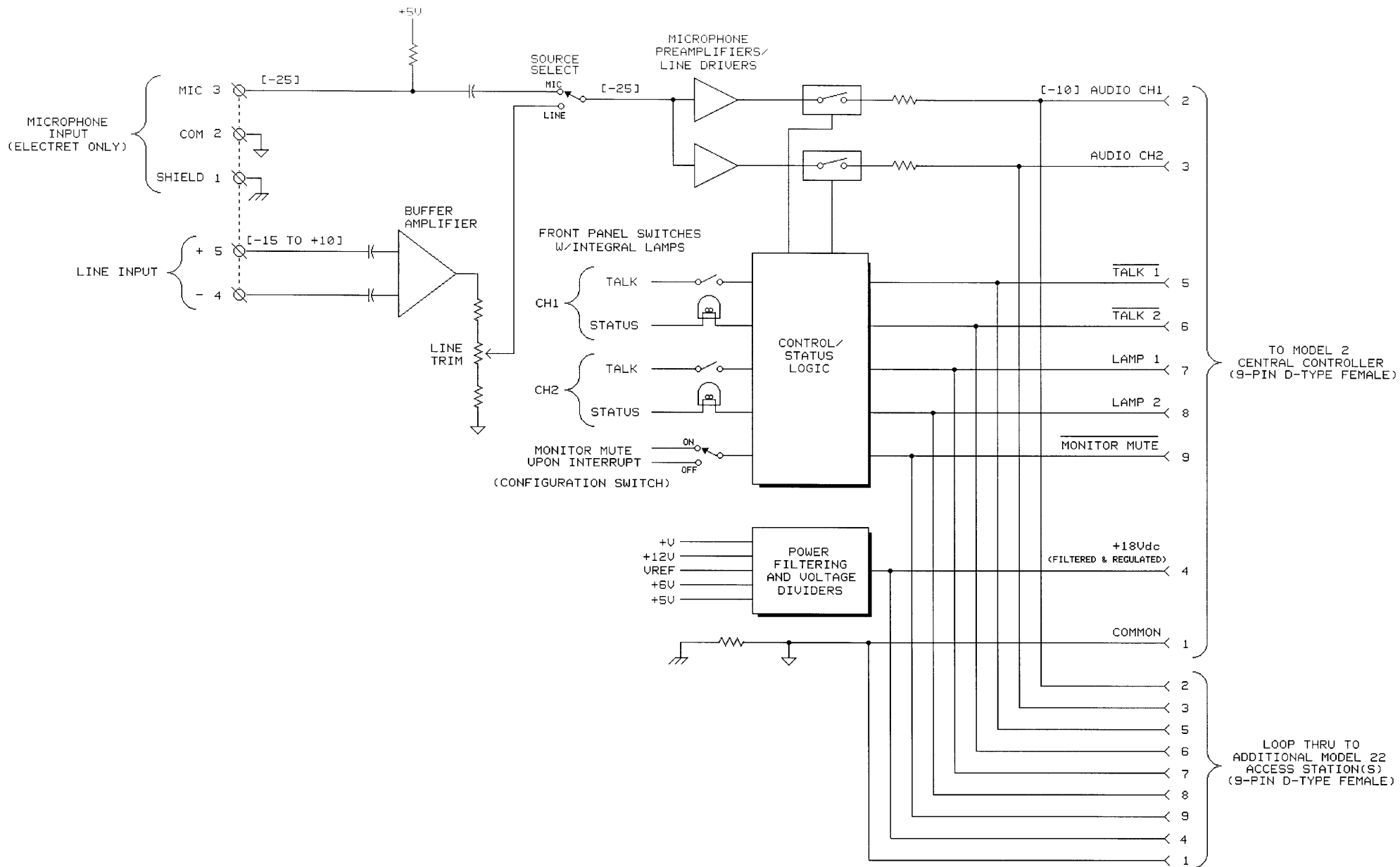


* LOCATED ON FRONT PANEL
 ** LOCATED ON REAR PANEL
 *** STANDARD PROGRAM AUDIO ROUTING
 (NOT PROCESSED BY COMPRESSOR/LIMITER)
 [NOMINAL LEVEL IN dBu]

STUDIO TECHNOLOGIES, INC.
 IFB PLUS SERIES
 MODEL 2 CENTRAL CONTROLLER
 BLOCK DIAGRAM



* LOCATED ON FRONT PANEL
 ** LOCATED ON REAR PANEL
 *** FACTORY OR FIELD CONFIGURABLE
 FOR 120 OR 220/240VAC OPERATION
 [NOMINAL LEVEL IN dBu]



STUDIO TECHNOLOGIES, INC.

IFB PLUS SERIES
 MODEL 22 ACCESS STATION
 BLOCK DIAGRAM

[NOMINAL LEVEL IN dBu]

PAGE 01 of 01

DATE 10/2/91

