

Model 392 Visual Alerting Unit Dimensions

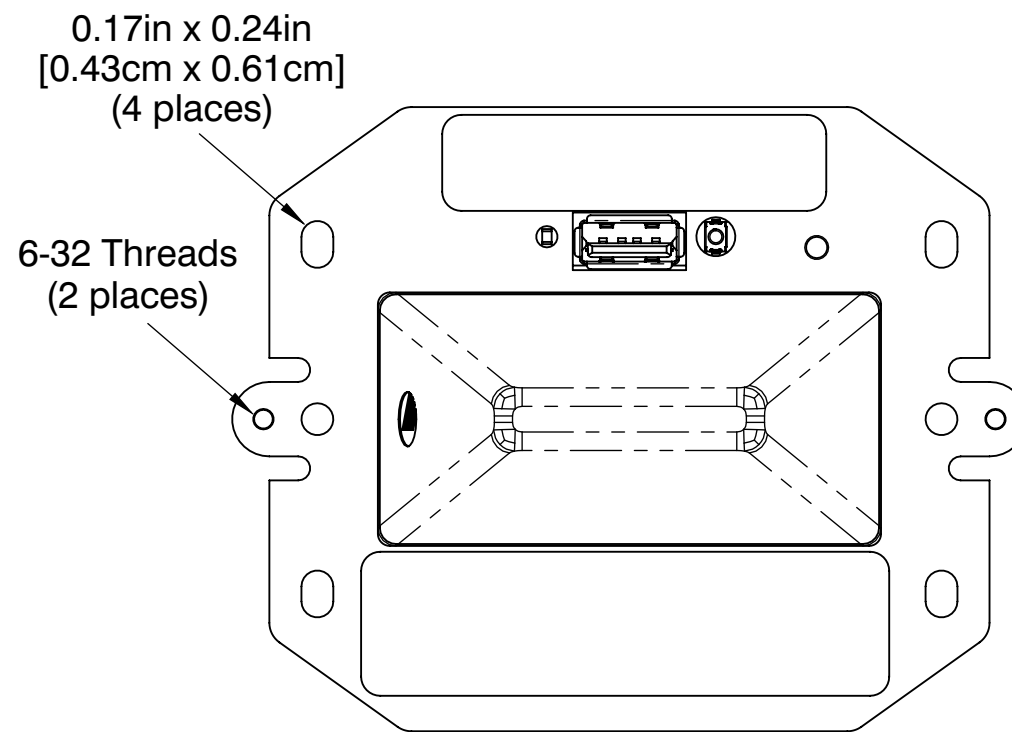

6-32 Thread (2 Included)

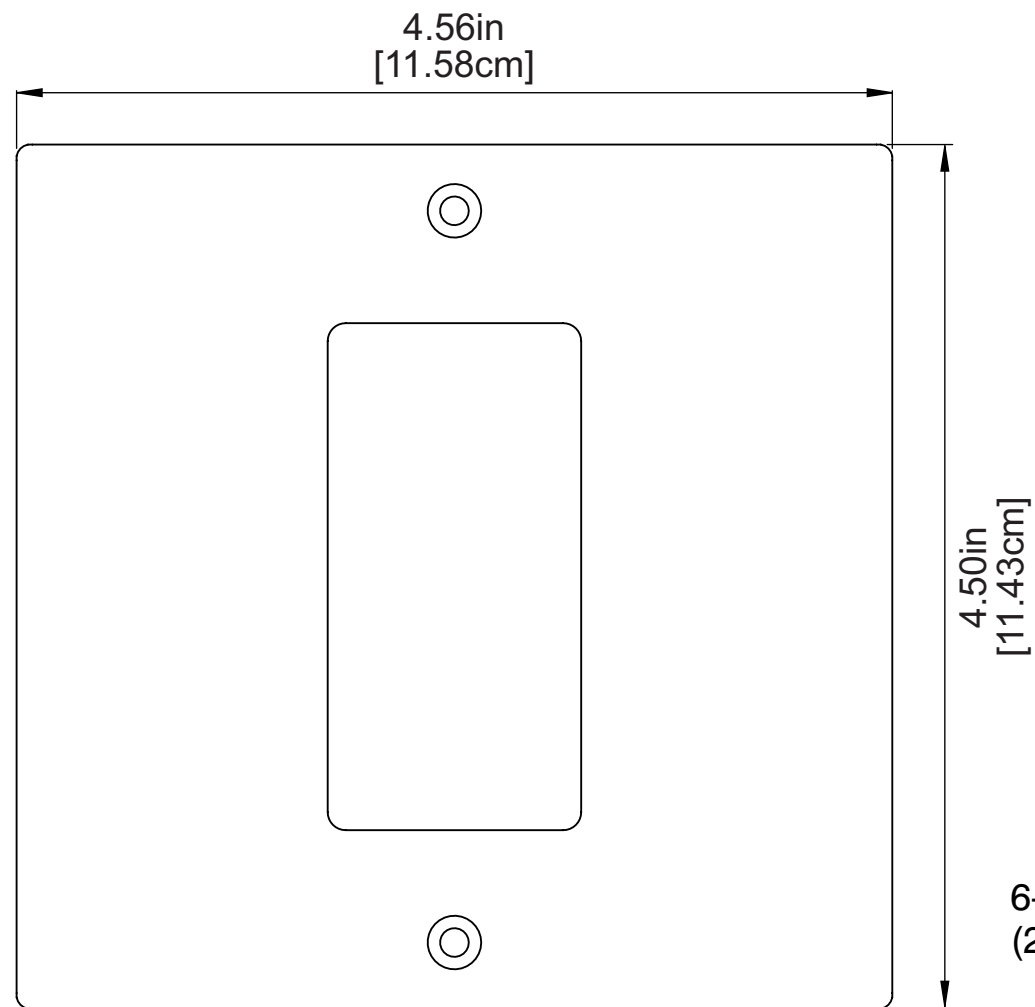
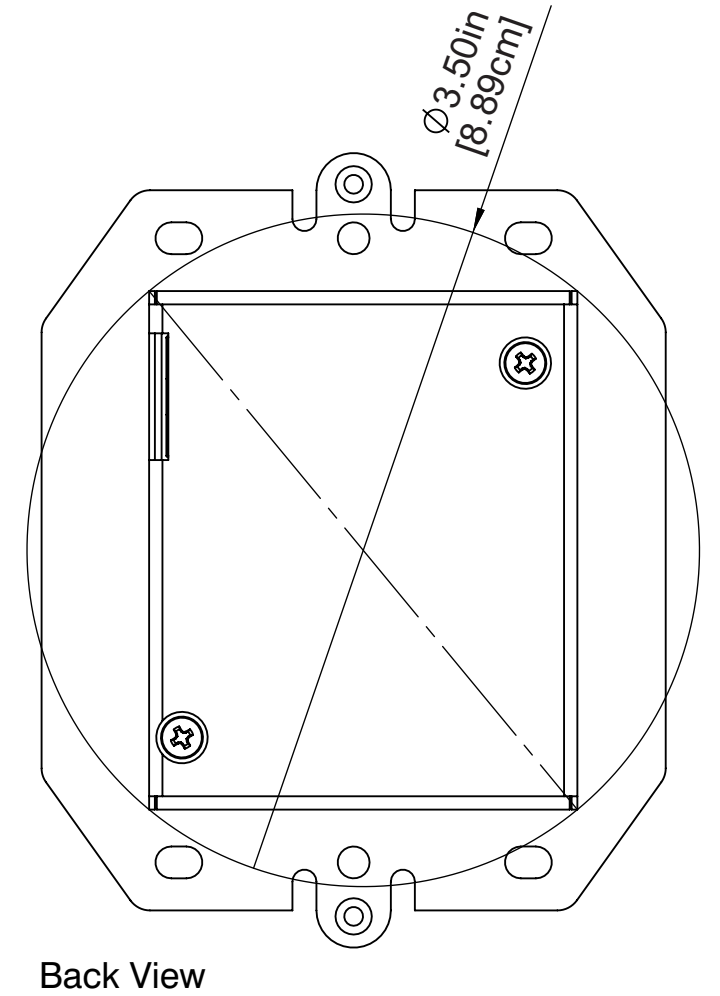
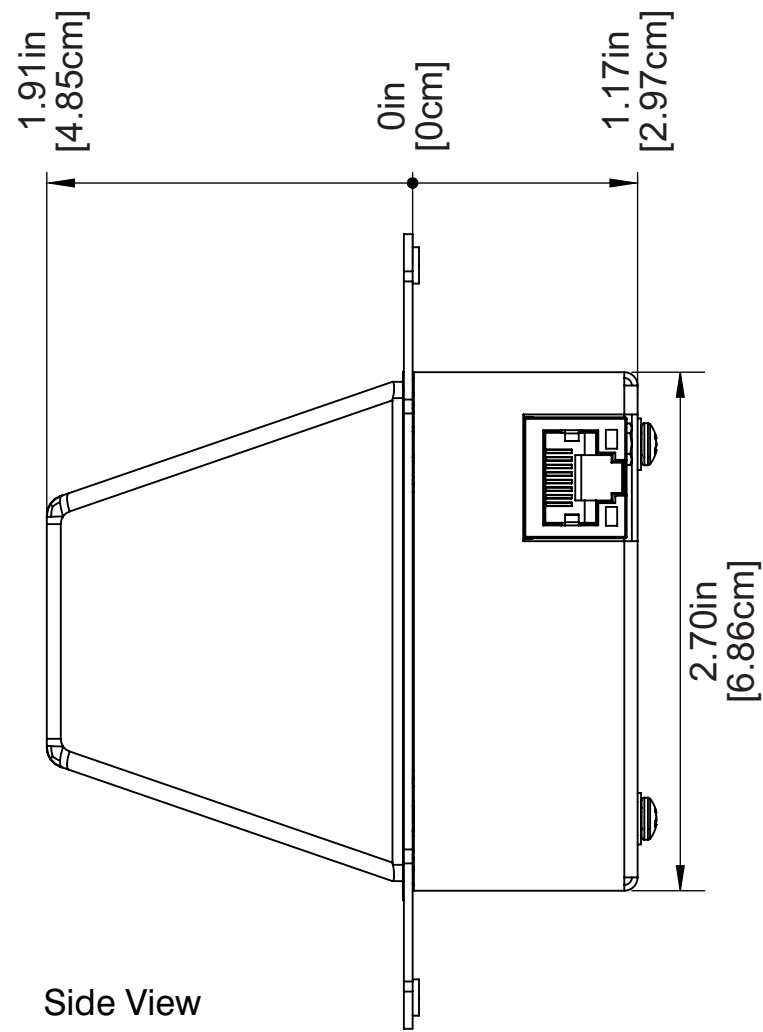
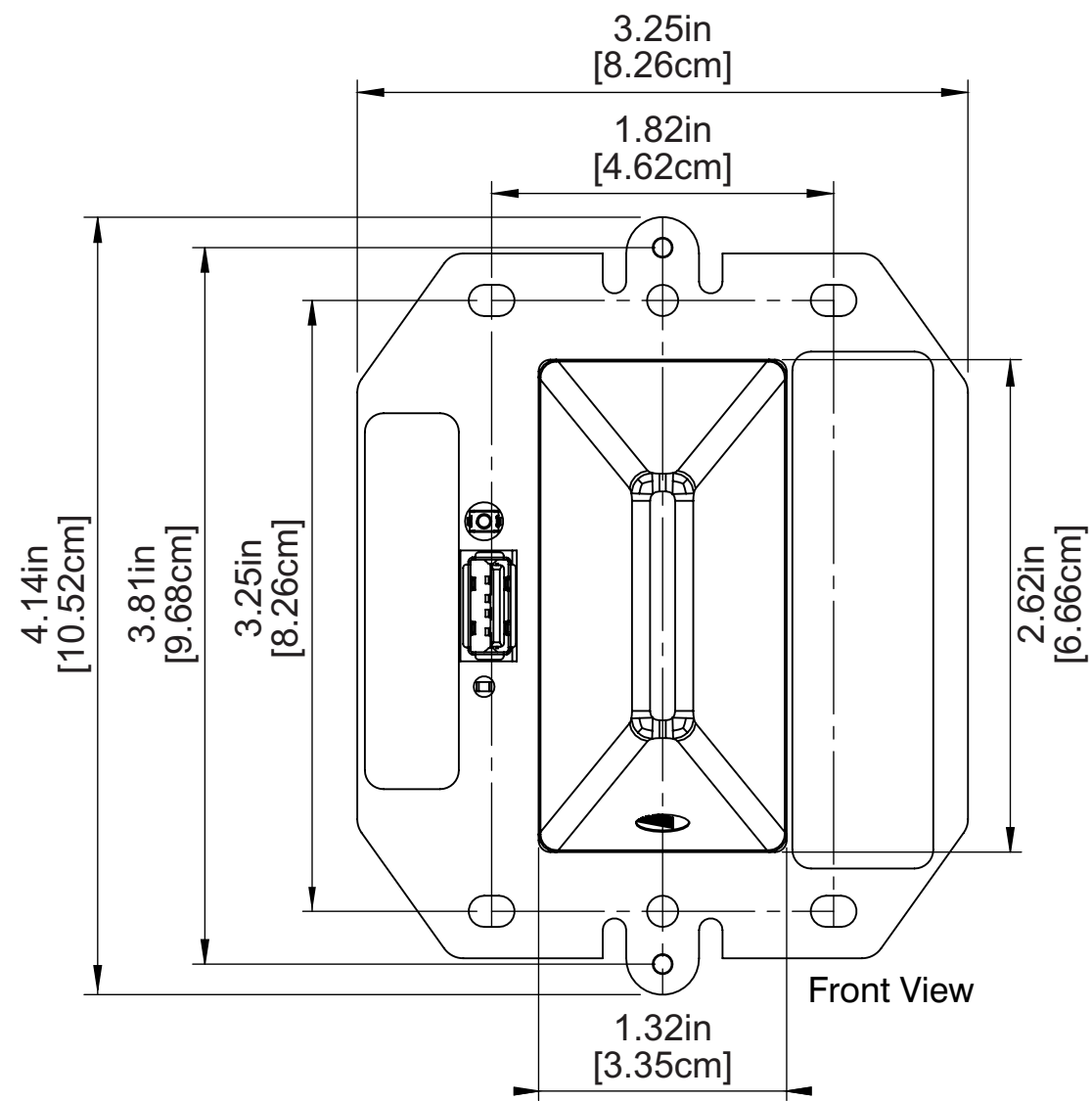
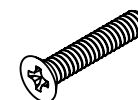

6-32 Thread (4 Included)

Recommended for use with any commercial electrical box, low-voltage device box, or suitable panel/drywall mounting bracket in a 2-gang configuration.

Recommended for horizontal or vertical wall mounting as shown. May also be mounted to ceilings.

Not recommended for use with gangable switch boxes or mounting methods with less than 1.5" usable depth.

Not recommended for outdoor use.