

# **Model 5121 Line/IFB Output Module**

## **User Guide**

Issue 3, October 2014

This User Guide is applicable for serial numbers  
M5121-00151 and later with firmware version 4.1 and higher

**Copyright © 2014 by Studio Technologies, Inc., all rights reserved**  
[www.studio-tech.com](http://www.studio-tech.com)

This page intentionally left blank.

# Table of Contents

Introduction.....	5
Installation .....	7
Configuration .....	9
Operation.....	9
Technical Notes .....	12
Specifications .....	16
Appendix A—Interconnection Details.....	17
Appendix B—Model 5121 Front Panel and Printed Circuit Board (PCB) Dimensions.....	19

This page intentionally left blank.

# Introduction

The Model 5121 Line/IFB Output Module is a compact, self-contained 2-channel module intended for use in custom broadcast, live-performance, and other specialized audio applications. The module provides broadcast and production talent cueing interfaces, specifically two line-level “dry” outputs and one powered “wet” IFB output, in an easy-to-use yet technically sophisticated package. (Note that IFB is an acronym for Interrupted Fold Back, an arcane broadcast technical term meaning the cue signals sent to on-air talent or other technical support personnel.) The module’s basic functions include analog and digital audio inputs, input level and status LED indicators, two analog line-level outputs, and a 2-channel powered “wet” broadcast-standard IFB output. Remote monitoring and control capability is included to support advanced applications. Module operation requires only a source of analog or digital audio, along with an externally-provided source of 12 volts DC.

Applications for the Model 5121 include sports broadcasting booth packages, remote news gathering “fly-packs,” stadium audio/video interface (I/O) locations, and other broadcast-infrastructure projects. The

number of Model 5121 modules used in a project can vary widely—from one to dozens. In each case the Model 5121’s performance will be completely “pro” with audio quality, reliability, and installation flexibility matching that of larger-scale audio consoles, matrix intercom systems, and stand-alone IFB systems.

Typical applications will find either or both of the Model 5121’s analog or digital audio inputs being interfaced with outputs provided by fiber-optic transport modules, audio/video routers, broadcast/production consoles, and matrix intercom systems. Only one of the audio inputs, analog or digital, will be used at any one time. No mixing of the signals will take place. While both physical inputs can be connected, by default the digital audio input will always take precedence. In the automatic selection mode the digital audio input will serve as the Model 5121’s audio source should it be present and “locked” to the input circuitry. The analog audio input will be active whenever a digital audio signal is not present and “locked.”

The Model 5121’s line-level outputs would typically be connected to battery-powered listen-only headphone amplifiers, amplified speakers, or inputs on broadcast media storage systems. In remote-broadcast

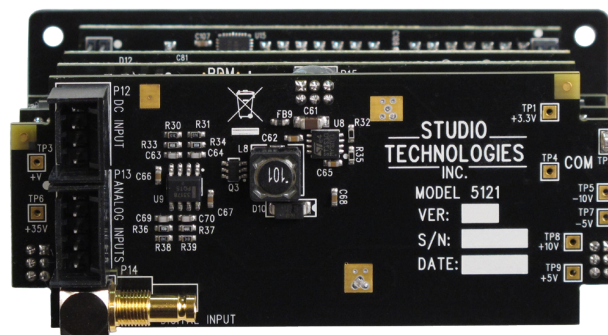
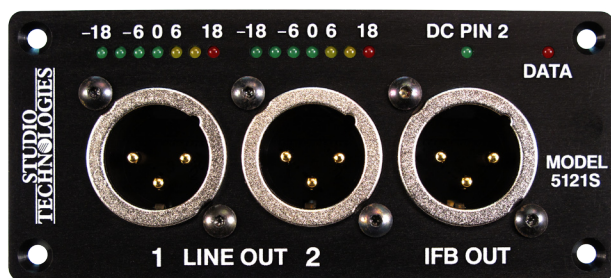

Figure 1. Model 5121S Line/IFB Output Module Front and Back Views

applications these two outputs may be referred to as “dry” (no DC voltage present) IFB signals. The Model 5121’s IFB output is directly compatible with listen-only portable IFB amplifiers, such as the Models 32A, 33A, or 34A from Studio Technologies, Inc. The 2-channel IFB output provides signal common on one pin, +28 volt DC power with superimposed channel 1 audio on a second pin, and channel 2 audio only on a third pin. This complies with a long-popular broadcast-standard implementation.

Model 5121 Line/IFB Output Modules do not include a mounting enclosure or chassis. They are intended for mounting in custom 19-inch rack panels, equipment boxes, broadcast furniture, “NEMA” I/O boxes, or other specialized enclosures. It is expected that integration firms will create applications that use Model 5121 modules as part of complete broadcast, production, corporate, and government solutions. Sophisticated users will be able to create “one-off” solutions to solve unique challenges.

Separate audio inputs are provided for interfacing with analog and digital audio sources. The two analog inputs are balanced and compatible with line-level signals. An unbalanced AES3 digital audio input allows the connection of two audio channels. By default, input source selection is automatic. If an AES3 digital audio source is connected it will have priority. Two 7-segment LED meters provide the user with an indication of the input levels.

The Model 5121’s audio performance is very good. Low-noise, wide dynamic-range circuitry ensures that the input audio quality is preserved. The audio source connected by way of the digital audio input is routed to a high-performance digital-to-analog converter (DAC) section that supports sample

rates of up to 48 kHz with a bit depth of up to 24. The two audio signals coming from the analog inputs or the DAC circuitry are routed to two line-level analog audio output sections. These provide the line-level, balanced, ESD-protected, capacitor-coupled output signals.

The two signals coming from the active audio input channels are also routed to the IFB circuitry. One channel is used to amplitude modulate the DC power source circuitry. The second channel is routed to a single-ended (unbalanced) line-driver circuit. The IFB circuitry provides a low-noise, current-limited source with a nominal 28 volt DC output. This is essentially identical to that created by “big time” broadcast IFB systems. Logic circuitry contained within the Model 5121 monitors the DC output voltage. Should a low-voltage/over-current condition be detected the DC output enters a protection mode. Once the fault condition is removed normal operation will again resume. An LED, located on the Model 5121’s front panel, provides an indication of the IFB output’s status. Note that for additional flexibility, the source impedance of the IFB output channels is 200 ohms. This allows intercom user belt packs to serve as listen-only devices as well as functioning as a small party-line intercom system.

All audio inputs and outputs were carefully designed for use in permanent as well as field applications. Filtering on the analog audio inputs minimizes the chance that radio frequency (RF) energy will interfere with audio input sources. Other components were included to address ESD (“static”) and DC over-voltage conditions. The DC power input is protected from accidental polarity reversal.

The Model 5121 requires an external source of nominal 12 volts DC for operation. The acceptable input voltage range is 10 to 18 allowing a variety of power sources to be utilized. Power supply circuitry within the Model 5121 creates the voltages required for the analog audio, digital audio, and IFB circuitry.

The Model 5121 uses standard connectors for fast, convenient interconnection. Line-level and IFB output connections are made using 3-pin male XLR connectors. The two analog audio inputs use a 5-position, 0.1-inch “header” connector. A DIN 1.0/2.3 coaxial connector is used to interface an AES3 unbalanced digital audio source. The DC power input and data bus connections use a 4-position, 0.1-inch header. Low-cost IDC (insulation displacement) mating connectors allow simple interconnection with the analog audio inputs and DC/data signals.

For compliance with international broadcast audio level standards two versions of the Model 5121 are available. The Model 5121S supports SMPTE® audio levels where the analog audio reference level is +4 dBu and the digital audio reference level is –20 dBFS (SMPTE RP155). The Model 5121E supports applications that require European Broadcast Union (EBU) compliance with an analog audio reference level of 0 dBu and a digital audio reference level of –18 dBFS (EBU R68).

The Model 5121 is compatible with the Studio Technologies’ Model 5190 Remote Access Module. This will allow monitoring and control, via an Ethernet connection, of several module operating and status parameters. A local RS-485 data bus allows up to 16 of the 5100-Series modules to be connected to a Model 5190. The status of the IFB DC output as well as the version number of the unit’s firmware can be observed. The audio

input source mode can be selected, with the choices being automatic, digital, or analog. In the automatic mode the digital input will have priority over the analog input. The gain of the input section can be adjusted with the supported range of  $\pm 12$  dB in 3 dB steps.

## Installation

Integration of the Model 5121 into the selected application is quite simple, only requiring connecting either or both analog and digital audio input sources along with DC power. Some applications will also require connection to the RS-485 data bus. The analog audio sources should have a nominal level of either +4 or 0 dBu, depending on the Model 5121 version being installed. The DC power source is nominal 12 volts with an acceptable range of 10 to 18 volts. The RS-485 data bus is a single pair of wires that would interconnect the Model 5121, along with other Model 5100-Series modules, to a Model 5190 Remote Access Module. After the connections have been completed, the module can then be secured into the designated mounting location.

## Analog Audio Inputs

The Model 5121 allows two channels of analog line-level audio to be connected. The input circuitry is electronically balanced and capacitor coupled. The nominal input level of Model 5121S (SMPTE) version modules is +4 dBu with a maximum allowable input level of +24 dBu. The nominal input level of Model 5121E (EBU) version modules is 0 dBu with a maximum allowable level of +18 dBu.

Connections to the audio inputs are made using a 5-position header connector located on the Model 5121’s rear-most circuit board.

For details on appropriate mating connectors refer to Appendix A located at the end of this document.

For connecting to balanced sources the signal + (high), signal – (low), and common/shield connections should be used. With unbalanced sources connect signal high to the Model 5121's signal + (high) and signal low to both the signal – (low) and common/shield connections. Refer to Figure 2 for details.

---

Pin Number	Function
1	Common/Shield
2	+ CH1
3	– CH1
4	+ CH2
5	– CH2

---

**Figure 2. Analog Audio Inputs**

## Digital Audio Input

The Model 5121's two audio input channels can be supplied in the form of a 75 ohm unbalanced digital signal that is compatible with the AES3 standard. The physical connection is made by way of a DIN 1.0/2.3-compliant receptacle. This receptacle is located adjacent to the analog audio input connector. This type of signal and connector is commonly used in broadcast and related applications. It was specifically selected for the Model 5121 because of its small size.

The digital audio input signal is intended to have a sample rate of 48 kHz, although the less-common 32 kHz and 44.1 kHz are also compatible. The recommended nominal level of the connected digital audio source will depend on the specific Model 5121 version

being installed. For Model 5121S (SMPTE) version modules the nominal level should be –20 dBFS. For Model 5121E (EBU) version modules the nominal level should be –18 dBFS.

## DC Input and Data Bus

A 4-position header, located adjacent to the analog audio input header, is used to connect DC power and a local RS-485 serial data bus to the Model 5121. Two pins on the mating connector are used to connect a source of nominal 12 volts DC. The acceptable range is 10 to 18 volts DC with a maximum current of 600 milliamperes at 12 volts DC. For remote control operation two pins on the mating connector will implement the data bus connection from a Studio Technologies' Model 5190 Remote Access Module.

Like the analog audio inputs, the mating connector is compatible with the AMP MTA series of IDC receptacles. It is, however, a 4-position rather than 5-position connector. For 22 AWG wire the closed-end-style receptacle is AMP 3-643813-4; the feed-through-style receptacle, used for busing connections, is AMP 3-644540-4. The body color for both receptacles is red, following the convention of the MTA-100 series for compatibility with 22 AWG wire. Refer to Appendix A of this guide for additional connector details.

- 
1. – DC (Common)
  2. + DC (10-18 volts)
  3. + Data (RS-485)
  4. – Data (RS-485)
- 

**Figure 3. DC Input and Data Bus Connections**



## Mounting

The Model 5121 is intended for mounting into an installation-specific enclosure or rack panel. Refer to Appendix B for the unit's dimensions and mounting screw locations. Please contact the factory to discuss mounting options.

## Configuration

### RS-485 Address

A data bus address must be configured for applications that implement remote control of Model 5121 functions. While up to 16 Model 5100-Series modules can “share” the RS-485 data bus, each module must have a unique address. Selecting the device's address involves setting four configuration switches located on one side of the module. The switches are a “piano key” type with their up position being defined as off and their down position defined as on. Note that switch 5 of the switch assembly is not used by the Model 5121. Refer to Figure 4 for details.

## Operation

The Model 5121 is designed for continuous operation with no adjustment or maintenance required. On the input side, maintaining the correct levels coming from the analog or digital audio sources is very important. This will ensure proper signal levels are being presented to users and maintain optimal audio fidelity. The audio meters and IFB output voltage status LED function (“DC PIN 2”) will assist users in confirming that correct operation is taking place. In addition, the under-voltage shutdown function will help to protect the IFB output circuitry should a fault condition be detected.

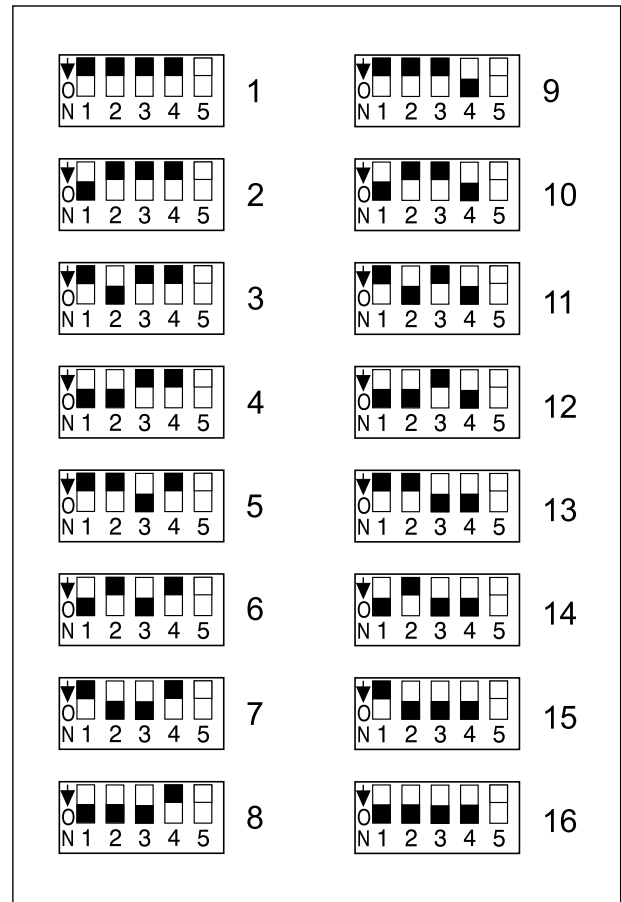

**Figure 4. RS-485 Address Settings**

The line outputs were designed for general-purpose use and can drive balanced or unbalanced loads. The IFB output is intended to directly support listen-only beltpacks such as the Models 32A, 33A, and 34 Talent Amplifiers from Studio Technologies.

### Level Meters

The two audio level meters on the Model 5121 are calibrated differently from typical “VU” meter scales. Their “steps” are labeled in reference to the nominal level of both the line and IFB outputs. For 5121S modules the green “0” LED corresponds to a +4 dBu line output and a –10 dBu IFB output audio level. For 5121E modules the “0” LED corresponds to 0 dBu and

–10 dBu output levels respectively. The ballistics of the meters is also different, being a cross between VU and peak.

The four green LEDs indicate that the output levels are in the normal range. The two yellow LEDs light when the signals are 6 to approximately 17 dB above the reference level. The red LEDs, labeled “18,” will light when the output levels have come close to, or have reached, the maximum level. An optimal input signal will result in the four green LEDs lighting almost solidly with the yellow LEDs lighting only on peak signals. The red LED lighting is not a good thing and indicates that the input signal level must be reduced.

## Line Outputs

The line outputs are designed for general-purpose use which could include connecting to externally-powered listen-only user beltpacks, transmitters associated with wireless in-ear monitors, audio consoles, or amplified speakers. The audio quality is such that using the line outputs for on-air applications would be appropriate. The outputs are analog, electronically balanced, capacitor coupled, and will perform optimally when driving loads of 2000 (2 k) ohms or greater. When using Model 5121S (SMPTE-compatible) modules the line output level will be +4 dBu when a signal at reference level is applied to the input. (A SMPTE reference level signal will either be +4 dBu for an analog audio source or –20 dBFS for a digital audio source.) With Model 5121E (EBU-compatible) modules the line output level will be 0 dBu when an input signal at reference level is applied. (An EBU reference level will either be 0 dBu for analog or –18 dBFS for digital.)

The Model 5121 provides two 3-pin male XLR connectors for interfacing with associated equipment. Pin 2 should be connected as signal + (high), pin 3 as signal – (low), and pin 1 as common/shield. To connect to an unbalanced load use pin 2 as signal + (high) and pin 1 as low/shield. Pin 3 should be left unconnected. To clarify, for correct unbalanced operation it is important not to connect pin 3 to anything, e.g., do not connect pins 1 and 3 together.

The line output circuitry is protected from damage should a moderate DC voltage be applied. For example, no damage will occur if a Model 5121’s IFB output (28 volts DC) is accidentally connected to one of the line outputs. This protection would also be effective should a party-line intercom circuit or microphone P48 phantom power signal be accidentally connected to a line output.

## IFB Output

One or more listen-only broadcast-standard IFB devices can be connected to the IFB output. The only restriction on the number of units that can be connected is that the total current draw must be equal to or less than 120 milliamperes. Devices such as the Studio Technologies’ Models 32A, 33A, or 34 are directly compatible and will provide excellent performance. While not cost-effective, it’s also possible to connect intercom beltpacks such as the RTS® BP325 as listen-only devices.

An interesting Model 5121 characteristic is that its IFB output maintains a 200 ohm impedance on both pin 2 and pin 3. This effectively creates a low-current party-line intercom power supply. With this capability two BP325 beltpacks connected to a Model 5121 IFB output cannot only listen to the IFB signals but also communicate between

themselves; a very small party line indeed, but possibly a useful one too.

The signals that are present on the IFB output's 3-pin male XLR connector are typical for broadcast powered "wet" IFB circuits. Pin 1 is common for power and audio, pin 2 is 28 volts DC with channel 1 audio modulated on it, and pin 3 is channel 2 audio. The nominal audio levels on the IFB channels are -10 dBu, no matter if the module is a 5121S (SMPTE version) or a 5121E (EBU version). The maximum current draw from pin 2 to pin 1 is 120 milliamperes. The circuitry associated with pin 3 is protected from damage should pin 2 (28 volts DC) be accidentally connected to it.

## DC Voltage Monitoring

The Model 5121's microcontroller integrated circuit, under firmware control, "watches" to ensure that the DC voltage present on pin 2 of the IFB output is at an acceptable level. The low-voltage threshold for the Model 5121's nominal 28 volt DC output is 24 volts. The DC Pin 2 status LED provides an indication of the DC voltage on the IFB output's XLR connector. The LED will "flash" at a moderate cadence if the voltage on the IFB circuit falls below the acceptable value. This can be caused by a temporary over-current or short-circuit condition, such as when interconnecting user devices to the IFB circuit using portable cabling.

An under-voltage condition that's present for a continuous 1-second period will cause a fault condition to be recognized. The status LED will indicate this condition by flashing at a faster rate. In addition, the output voltage on the IFB circuit will automatically shut down to an essentially off condition. A 5-second "cool-down" period will then take place, after which the output voltage will

again become active. As soon as the output is enabled normal output voltage monitoring will again take place. A continuous short-circuit presented to the IFB output will result in a continuous 4-seconds-on, 5-seconds-off error cycle. It's important to note that during the 5-seconds-off period no voltage monitoring takes place. Removing the fault condition will not result in the output voltage immediately turning on again; the 5-second shut-down period must first elapse.

## Remote Monitoring and Control

Several of the Model 5121's functions are capable of being monitored and controlled remotely. Implementing these functions requires use of a Studio Technologies Model 5190 Remote Access Module. The two modules, along with up to 15 more, will interconnect using a local RS-485 data bus. The remote monitoring functions include observing the status of the IFB DC output and viewing the version number of the Model 5121's firmware (embedded software). The remote control capability includes input source selection and input source level. By default the automatic input source selection mode will be active. In this mode the digital input source will take precedence over the analog input source. If a digital audio input signal is connected and "locked" with the input circuitry its two audio channels will be used as the Model 5121's audio sources. The audio sources can also be selected to always use the digital input or always use the analog input.

The gain of the two audio channels can be independently adjusted over a range of  $\pm 12$  dB in 3 dB steps with the default setting being 0 dB. The selected value applies whether the audio source comes from the

digital input or one of the analog inputs. The ability to adjust the audio level can be useful when the sources being supplied to the Model 5121 are not optimal for the application. For example, users of the line-level or IFB outputs may need additional gain to clearly hear their talent cues.

The Model 5121's gain values can only be viewed and adjusted using a Model 5190 Remote Access Module. But the actual values are stored in non-volatile memory that is part of the Model 5121's circuitry. Upon power up the Model 5121 will always use these stored gain values, whether or not a Model 5190 is currently connected and communicating.

The data LED, located on the Model 5121's front panel, will light whenever data activity is taking place over the local RS-485 signal bus that is used to link the Model 5121 to a Model 5190 Remote Access Module. The LED will flash on and off each time data associated with this specific Model 5121 is present. Not all applications will include a connection to the data bus so it's certainly possible that the data LED may never flash except during module power up.

## Technical Notes

### Maintaining Correct Input Signal Levels

The Model 5121's two audio inputs are designed for either SMPTE (5121S) or EBU (5121E) audio level compatibility. Applying signal levels significantly lower than the intended nominal will reduce the signal-to-noise ratio (raising the perceived noise floor) and can prevent the connected user devices from operating optimally. Applying signal levels significantly higher than nominal will

reduce the headroom and greatly increase the chance of reaching audio "clipping." Obviously, these cautions are not unique to the Model 5121, but apply to most audio equipment. The front-panel level meters provide an easy means of confirming that a Model 5121 is being presented with the correct audio levels.

For the Model 5121S the nominal input signal level is +4 dBu for an analog source and -20 dBFS for a digital source. For the Model 5121E the nominal input level is 0 dBu for analog and -18 dBFS for digital. The analog output level for nominal level input signals is +4 dBu for the Model 5121S and 0 dBu for the Model 5121E. For both versions the nominal output level of the two channels associated with the IFB output is -10 dBu. (Of course pin 2 on the IFB output has both DC and audio present on it.)

To confirm correct IFB circuit operation at locations away from where the Model 5121 is installed, it's possible to use the Model 72 Level Meter/Interface, also available from Studio Technologies. The Model 72 is a compact, portable device that plugs directly into an IFB or intercom circuit and provides two useful functions. Two 5-segment LED meters display the audio levels present on pins 2 and 3. In addition, "dry" line-level audio outputs are provided, one for each channel. Complete information on the Model 72 is available on the Studio Technologies website.

### Maintaining Correct IFB Circuit Current Draw

The Model 5121's IFB output is designed to provide up to 120 milliamperes of DC current. By design, the IFB circuit is protected so that an overload condition, or even a complete short circuit, should not cause

damage. Exceeding 120 milliamperes for more than one second will cause the auto shut-down mode to become active. A continuous overload condition will cause the output voltage to cycle through a 1-second-on, 5-seconds-off sequence. Restoring the output load to be within the rated 120 milliamperes will allow the IFB output to again operate normally. In extreme cases, such as where the Model 5121 is located in an environment with elevated temperatures, a few minutes may be required from the time an overload condition is removed to when normal operation will again take place. Please don't test the Model 5121's ability to sustain frequent overload or short-circuit conditions! The long-term reliability of the unit can be impacted by the stresses caused by these fault conditions.

The DC Pin 2 status LED makes it simple to know if an excessive load, or a short circuit, is being placed on the IFB circuit. Technically the LED, under software control, provides a direct indication of the IFB circuit's DC output voltage. And the output voltage is directly related to the amount of current being drawn.

The LED lights steadily when the IFB's DC output is within its normal range. During normal operation the DC level on pin 2 of the IFB output will be approximately 28 volts. The LED will begin to flash on and off if the level falls below approximately 24 volts DC. This will occur when the current draw is greater than nominally 120 milliamperes. If the fault lasts for more than one second the LED will flash at a faster rate. In addition, the DC output will shut down for a 5-second period.

There's really only one piece of advice when it comes to understanding how to use the status LED: if it flashes there's a problem

that must be corrected! The most likely cause will be too many user devices being connected to the IFB output connector. It's also possible that a wiring problem could cause a partial or full short circuit between pin 1 (common) and pin 2 (power with channel one audio). Troubleshooting should prove quick and easy. Begin by disconnecting the IFB user devices. Observe the status LED and see if the problem has gone away. If not, review the interconnecting cables and find the fault condition. Within five seconds of the problem being "cleared" the status LED will stop flashing.

## Cable Length

There are no "hard and fast" rules defining the maximum cable length possible when connecting user devices to the Model 5121's IFB output. The maximum cable length is directly related to the amount of resistance in the connecting cable; the lower the resistance per foot (or meter), the longer the cable can be (although cable capacitance affects high-frequency performance, resistance is the limiting factor in most cases). For example, a contemporary microphone cable is Belden 1172A which has 18 ohms resistance per conductor per 1000 feet. Since we're using two conductors to carry the signal (pins 1 and 2) you'd get 36 ohms per 1000 feet of cable. By knowing the cable resistance value, along with the minimum voltage and maximum load current required by an IFB user device, a simple "ohms law" calculation will tell you the maximum cable length.

Let's use the example of a Studio Technologies Model 32A Talent Amplifier being connected to a Model 5121 IFB circuit. We'll select Belden 1172A as the interconnecting cable. For correct operation, the Model 32A needs at least 24 volts DC between pins

1 and 2 of its IFB input connector. It has a current draw of 35 milliamperes. The Model 5121's IFB circuit presents an output voltage of 28 volts across pins 1 and 2 and can supply a maximum current of 120 milliamperes. (As the Model 32A's current draw is well within the Model 5121's capability, this is not a limiting factor.) The difference between the voltage supplied by the Model 5121 (28 volts) and the voltage required by the Model 32A (24 volts) allows a 4 volt maximum drop over the interconnecting cable. Using the current draw and maximum voltage drop figures, the maximum cable resistance can easily be calculated: 4 volts divided by 0.035 amperes equals 114 ohms. And finally, with 1172A's 36 ohms (total) per 1000 feet of cable, a maximum of approximately 3100 feet of cable can be used and still be less than or equal to 114 ohms. Using this example as a guide, entering the appropriate values will allow you to determine the maximum cable length for your application.

## **Cabling Issues – Crosstalk**

The Model 5121's IFB output conforms to a broadcast-industry standard for sending DC power and two channels of audio over a single pair with shielded audio cable. This implementation allows standard portable cables, such as those used for microphone signals, to interconnect various IFB user devices. This method is undoubtedly convenient and practical, but is not without limitations. The main audio quality issue is the possibility of crosstalk between the two audio channels. This issue arises due to the capacitance presented by the two wires that form the twisted pair. The greater the capacitance presented and the longer the cable run, the greater the crosstalk. Is this normally a problem during actual use? No. But it's something that should be noted.

## **Superior Power Delivery and Audio Quality**

One of the Model 5121's strengths is its ability to very effectively deliver energy to the connected IFB user devices. This allows the devices to be supported over longer cable runs. How does the Model 5121 accomplish this? Simply by having circuitry that is superior to that used in most of the "industry-standard" equipment. In most IFB interface devices, an adjustable voltage regulator integrated circuit is used as a combination of audio modulator and current limiter. While this is a simple and inexpensive solution, it's not without significant limitations. The major problem with this method is the type of voltage-current "knee" that is created. As the load current increases past about 50 percent of the rated maximum the output voltage begins to decrease. This means that the usable power delivered to the connected device(s) will start to drop well before the rated output is reached. This limitation will become significant in applications that use long cable runs. As the IFB circuit voltage begins to drop problems with user device performance can occur.

Contrast this situation with the performance provided by the Model 5121. The DC voltage supplied by its IFB circuit won't "poop out" when loaded over its entire 0 to 120 milliamperage range. This will allow IFB belt-pack devices to work correctly in many more applications.

It's also interesting to note the reason why typical IFB circuit audio quality is less than pristine. It's not hard to notice the background "hiss" that is seemingly always present on pin 2 (DC with channel 1 audio) of the interface connector. Technically, it's white noise that comes from the adjustable voltage regulator being used as an "AM"

modulator and current limiter. The noise is an artifact of the design topology and simply can't be overcome. How does Studio Technologies know this? Because our first "breadboard" designs used this method and achieved the same poor results! Only after the problem came to light did work on an improved circuit begin. The result was well worth the effort.

## Firmware Version Display

After the Model 5121's power-up sequence is completed, the unit's LEDs are used to automatically display the firmware (embedded software) version number. This is useful when working with factory personnel on application support and troubleshooting situations. The seven LEDs associated with the channel 1 audio level meter are used to display the major version number with a range of 1 through 7. The seven LEDs associated with the channel 2 audio level meter are used to display the minor version number which ranges from 0 to 7. (No lit channel 2 LEDs indicates minor version number 0.) The firmware version number

will display for approximately one second after the power-up sequence has completed but before normal operation will begin. Refer to Figure 5 for a detailed view of the LEDs and the corresponding firmware version numbering scheme.

Note that while it's easy to determine which firmware version is loaded into the Model 5121 a trip back to the factory is required to update it. The 8-bit microcontroller that provides the unit's logic "horsepower" also includes internal FLASH memory. This non-volatile memory is used to store the operating firmware. Re-programming this memory requires using a specialized programming unit. While not outrageous in price, it still costs in the range of US\$500. The programmer uses a ribbon cable and socket to interface with a 6-pin "header" on one of the Model 5121's printed circuit boards. As you would guess, once connected reprogramming takes only a matter of seconds. But unfortunately the programmer is not something that would be found in a typical "field shop" or repair facility.

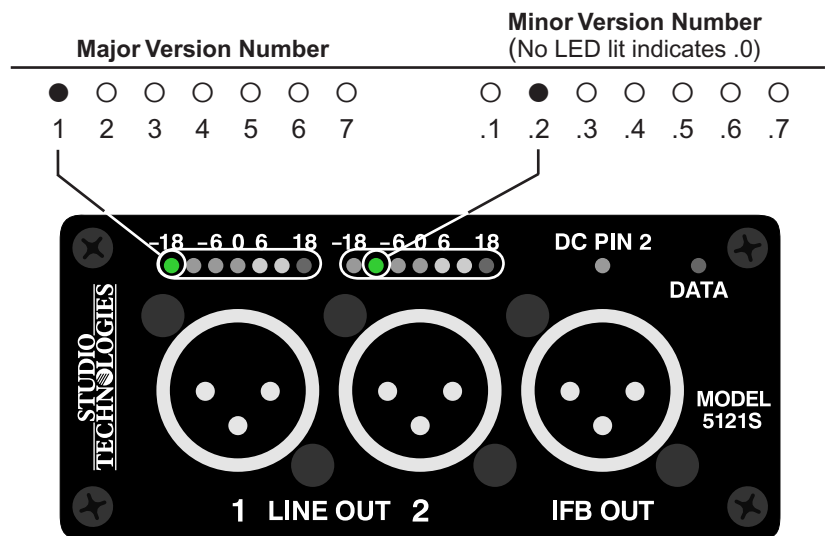

Figure 5. Detail of front panel showing the level meter LEDs that display the firmware (embedded software) version. In this example, the firmware version is 1.2.

# Specifications

## Digital Audio Input: 1 (2-channel)

**Type:** AES3, unbalanced, 75 ohms

**Maximum Sample Rate/Bit Depth:** 48 kHz/24

**Nominal Level:** -20 dBFS (Model 5121S);  
-18 dBFS (Model 5121E)

## Analog Audio Inputs: 2

**Type:** electronically balanced, capacitor-coupled,  
20 k ohms

**Nominal Level:** +4 dBu (Model 5121S), 0 dBu  
(Model 5121E)

**Maximum Level:** +24 dBu

## Analog Inputs to Line Outputs:

**THD+N:** 0.005% (-86 dB), +4 dBu input, 1 kHz

**Frequency Response:** ±2 dB, 20 Hz to 20 kHz

**Signal-to-Noise Ratio (A-Weighted):** 93 dB

**Dynamic Range:** 113 dB

**Crosstalk:** 105 dB, +23 dBu in, 1 kHz and 10 kHz

## Digital Inputs to Line Outputs:

**THD+N:** 0.022% (-73 dB), +4 dBu input, 1 kHz

**Frequency Response:** ±1 dB, 20 Hz to 20 kHz

**Signal-to-Noise Ratio (A-Weighted):** 82 dB

**Dynamic Range:** 102 dB

**Crosstalk:** 98 dB, -1 dBFS in, 1 kHz; 91 dB,  
-1 dBFS in, 10 kHz

## Digital Inputs to IFB Output, Pin 2:

**THD+N:** 0.07% (-63 dB), +4 dBu input, 1 kHz

**Frequency Response:** ±1 dB, 100 Hz to 20 kHz

**Signal-to-Noise Ratio (A-Weighted):** 64 dB

**Dynamic Range:** 84 dB

## Digital Inputs to IFB Output, Pin 3:

**THD+N:** 0.03% (-71 dB), +4 dBu input, 1 kHz

**Frequency Response:** ±1 dB, 20 Hz to 20 kHz

**Signal-to-Noise Ratio (A-Weighted):** 70 dB

**Dynamic Range:** 90 dB

## IFB Output:

**Type:** DC power with two channels of unbalanced  
audio

**Connections:** common on pin 1, DC (+28 V  
nominal) modulated with channel 1 audio (-10 dBu  
nominal) on pin 2, channel 2 audio (-10 dBu  
nominal) on pin 3

## Maximum Audio Output Level:

Pin 2: +9 dBu with +23 dBu on analog audio  
input

Pin 3: +10 dBu with +24 dBu on analog audio  
input

**DC Current Output:** 120 milliamperes maximum

**Output Impedance:** 200 ohms, nominal

**Meters:** 2, 7-segment LED, modified VU ballistics

## Remote Control:

**Data Interface:** RS-485 115.2 Kb/s, 8-1-N

**Compatibility:** Studio Technologies' Model 5190  
Remote Access Module

**Functions Supported:** input source selection,  
input signal level, IFB DC output voltage status

## Connectors:

**Line and IFB Outputs:** 3, 3-pin male XLR

**AES3 Digital Audio Input:** 1, DIN 1.0/2.3-  
compliant coaxial

**Analog Audio Inputs:** 1, 5-position male header.  
Refer to Appendix A for mating connector details.

**DC Input/Data:** 1, 4-position male header. Refer  
to Appendix A for mating connector details.

**Power Requirement:** 12 volts DC nominal, 600  
milliamperes max; acceptable range 10-18 volts  
DC, 700 milliamperes max at 10 volts

## Dimensions (Overall):

3.75 inches wide (9.5 cm)

1.69 inches high (4.3 cm)

2.30 inches deep (5.8 cm)

**Mounting:** requires custom implementation;  
no mounting method provided. Refer to Appendix B  
for details.

**Weight:** 0.2 pounds (91 g)

Specifications and information contained in this  
User Guide subject to change without notice



## Appendix A—Interconnection Details

The required mating receptacles are from the TE Connectivity (formerly AMP) MTA-100 series of IDC (insulation displacement) connectors. This series was selected because of its low-cost and wide range of offerings. Separate connectors are offered for compatibility with 22, 24, 26, and 28 AWG (American Wire Gauge) insulated wire. The connector color indicates its AWG-compatibility. Unfortunately, with flexibility can come some confusion. The MTA-100 offers a number of different connectors that will work with the Model 5121's analog audio inputs and DC input/data headers. Before obtaining receptacles it's important to determine two things: wire gauge and wiring arrangement.

### **Analog Audio Inputs** (one connector required)

- For 22 AWG wire this receptacle (red in color) is recommended:
  - TE Connectivity (AMP) 3-643813-5
  - Digi-Key part number A31109-ND ([www.digikey.com](http://www.digikey.com))*
  - Mouser part number 571-3-643813-5 ([www.mouser.com](http://www.mouser.com))*
- For 24 AWG wire this receptacle (white in color) is recommended:
  - TE Connectivity (AMP) 3-643814-5
  - Digi-Key part number A31020-N*
  - Mouser part number 571-3-643814-5*

### **DC Input/Data** (one connector required)

- For 22 AWG wire this receptacle (red in color) is recommended:
  - TE Connectivity (AMP) 3-644540-4
  - Digi-Key part number A31122-ND*
  - Mouser part number 571-3-644540-4*

### **Tools for Connecting Wires to the Mating Receptacles**

For applications where just a few Model 5100-Series modules are going to be installed a manual IDC termination tool is recommended. While requiring a steady hand to achieve reliable wire connections to the mating receptacles, the price, at less than US\$40, is fairly reasonable:

- “T Handle” termination hand tool:
  - TE Connectivity (AMP) 59803-1
  - Digi-Key part number A9982-ND*
  - Mouser part number 571-598031*

## Appendix A—Interconnection Details, continued

### Tools for Connecting Wires to the Mating Receptacles, continued

For applications where a larger number of Model 5100-Series modules are going to be installed it's worth considering a semi-automatic termination tool. The recommended tool consists of a handle assembly and crimp die for MTA-100 receptacles. The total price for both, approximately US\$300 as of this writing, is steep but the performance that this tool assembly provides is excellent. We feel that the time savings and reliability of the connections warrants the price when many terminations are going to be made:

- Handle Tool, Pistol Grip:  
TE Connectivity (AMP) 58074-1  
*Digi-Key part number A2031-ND*  
*Mouser part number 571-580741*
- Crimp Head Die Assembly for MTA-100 Receptacles:  
TE Connectivity (AMP) 58246-1  
*Digi-Key part number A1998-ND*  
*Mouser part number 571-58246-1*

### Headers on the Printed Circuit Board

The actual part numbers of the header connectors that are soldered into the Model 5121's printed circuit board are provided in this section. But do not order these part numbers with the intent of interconnecting signals with the Model 5121! We are providing these details only so that interested technical personnel can have the full background on the Model 5121's interconnect system. The appropriate mating receptacles are detailed in a previous section of this Appendix.

- Analog Audio Inputs (one header):  
TE Connectivity (AMP) 2-644486-5 **(DO NOT ORDER THIS NUMBER!)**
- DC Input/Data (one header):  
TE Connectivity (AMP) 2-644486-4 **(DO NOT ORDER THIS NUMBER!)**

## Appendix B—Model 5121 Front Panel and Printed Circuit Board (PCB) Dimensions

STUDIO TECHNOLOGIES, INC.  
MODEL 5100-SERIES SINGLE-WIDTH FRONT PANEL  
AND PRINTED CIRCUIT BOARD DIMENSIONS  
(DIMENSIONS SHOWN IN INCHES)  
(AS OF SEPTEMBER 2013, APPLIES TO  
MODELS 5110, 5120, 5121, 5130, 5132, 5134, 5150, 5152, 5154, 5180, AND 5190)

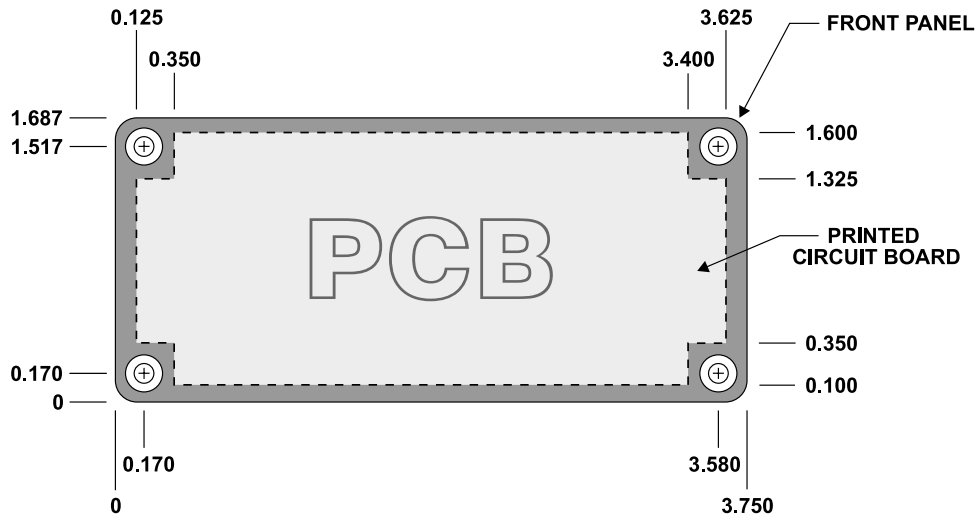

**NOTES:**

- 1) OPENING MUST BE MADE IN CUSTOM-MOUNTING ARRANGEMENT SO THAT PCB IS ALLOWED TO FREELY PASS THROUGH.
- 2) FRONT-PANEL MOUNTING LOCATIONS DIMENSIONED FOR #4 COUNTERSUNK SCREWS (4 PLACES). UNDERCUT FLAT-HEAD MACHINE SCREWS RECOMMENDED.
- 3) RECOMMENDED MOUNTING-HOLE LOCATIONS SHOULD BE DRILLED AND TAPPED FOR 4-40 SCREW THREADS (4 PLACES).

**WARNING:**  
THIS DRAWING SHOWS THE DIMENSIONS OF THE PRINTED CIRCUIT BOARD.  
PANEL OPENING MUST BE MADE LARGER TO ALLOW PCB TO PASS THROUGH!  
CONTACT FACTORY IF YOU HAVE QUESTIONS.