

# **Model 208 Announcer's Console**

## **User Guide**

Issue 2, October 2018

This User Guide is applicable for serial numbers  
M208-00151 and later with application firmware 1.4 and later

**Copyright © 2018 by Studio Technologies, Inc., all rights reserved**

[www.studio-tech.com](http://www.studio-tech.com)

This page intentionally left blank.

# Table of Contents

Revision History .....	4
Introduction.....	5
Getting Started .....	9
Operation.....	18
Technical Notes .....	24
Specifications .....	28
Appendix A: Views of Model 208 with Optional MBK-02 Mounting Brackets.....	29
Appendix B: Model 208 Block Diagram.....	30

# Revision History

## **Issue 2, October 2018:**

- Documents addition of the Push to Mute/Tap to Latch mic on/off button mode.

## **Issue 1, January 2018:**

- Initial release.

# Introduction

The Model 208 Announcer's Console offers a unique combination of analog and digital audio resources for use in broadcast sports, eSports, live event, entertainment, and streaming broadcast applications.

The unit is housed in a compact enclosure that's intended for table-top use. Optional mounting brackets provide a simple means of integrating the Model 208 into a variety of broadcast furniture or on-air sets. The Model 208 supports Dante® audio-over-Ethernet digital media technology as well as AES67 for integration into contemporary applications. The unit is extremely simple to deploy, is “pro” quality throughout, and provides an intuitive user experience. The Model 208's audio quality is excellent, with low distortion, low noise, and high headroom. Careful circuit design and rugged components ensure long, reliable operation.

The Model 208 integrates directly into both Dante audio-over-Ethernet and standard analog audio environments. With just a Power-over-Ethernet (PoE) connection, a microphone, and a pair of headphones or an earpiece, a complete broadcast on-air position can be created. And by using the Model 208's microphone output a direct connection to an analog microphone-level input on an associated camera, remote I/O

interface, or audio console can be supported. Contact inputs allow external signals to work in conjunction with the mic on/off button and talkback button functions.

Key Model 208 features are configured using the STcontroller personal computer software application. An extensive set of parameters allows the unit's operation to be tailored to meet the needs of many applications. STcontroller, compatible with version 7 and later of the Windows® operating system, is a fast and simple means of confirming and revising the unit's operating parameters.

## Applications

The Model 208 on its own can provide an “all-Dante” solution for one on-air talent location. A wide range of applications can be supported, including sports and entertainment TV and radio events, streaming broadcasts, corporate and government AV installations, and post-production facilities. Two Dante receiver (audio input) channels supply the user with their talent cue (IFB) signals. Should the cue signal be “mix-minus” an integrated sidetone function can provide the user with a microphone confidence signal. Two Dante audio output channels, one designated as main (for on-air) and the other talkback, are routed via an associated local-area network (LAN) to inputs on Dante-compatible devices.



Figure 1. Model 208 Announcer's Console front and rear views

Two pushbutton switches, microphone on/off and talkback, provide the user with direct control over audio routing. The audio switching is performed in the digital domain and is virtually “click-free.”

By providing the main (on-air) audio signal in two forms, Dante digital audio and analog microphone level, the Model 208 makes integration into a wide range of environments easy to accomplish. And with the talkback audio available as a Dante output channel, routing to inputs on a variety of devices, such as matrix intercom systems, audio consoles, and monitor loudspeaker systems, is simple and flexible.

Some applications may benefit from not utilizing the Model 208's Dante main output channel. This typically won't be an issue of inadequate audio quality but rather a need to match work-flow requirements. For example, for lip-sync or transmission purposes it may be optimal to have the on-air audio transported as an embedded signal along with the associated camera video. Alternately, all on-air audio sources may need to connect to inputs on an audio console or console-related I/O unit. Supporting these scenarios is not a problem as the Model 208 supplies a microphone output connection that's specifically intended for this purpose. Simply connect the unit's microphone output connection to the desired analog input, such as the mic/line input on an ENG-style camera—that's it!

The circuitry associated with the Model 208's analog microphone output is very simple, essentially a passive path that routes a signal connected to the microphone input connector directly to the microphone output connector. A solid-state circuit, in series with the mic in-to-mic out

path, allows muting of the signal on the microphone output connector whenever the microphone output is off or the talkback function is active. And it's important to note that using the microphone output connection doesn't impact the normal functioning of the Dante main and talkback output channels. This can be valuable, such as when utilizing the Dante main output channel as a backup, secondary, or redundant on-air audio signal.

## Setup and Operation

Set up, configuration, and operation of the Model 208 is simple. An etherCON® RJ45 jack is used to interconnect with a standard twisted-pair Ethernet port associated with a PoE-enabled network switch. This connection provides both power and bidirectional digital audio. A broadcast headset or handheld (“stick”) microphone can be directly connected to the unit's 3-pin XLR mic input connector. The input is compatible with a dynamic or condenser microphone. The integrated P48 phantom power source allows operation with a wide range of condenser microphones. A 3-pin XLR mic output connector provides a “direct mic out” function for integration with mic inputs on related devices. Stereo headphones, the headphone connections from a stereo or monaural headset, or even a monaural earpiece can be connected to the phones output jack. External switches can be connected to the Model 208 to allow remote control of the button functions. The STcontroller software application is used to configure the wide range of Model 208 operating parameters. This allows the unit's performance to be optimized to meet the needs of specific applications.

The user is presented with two pushbutton switches and three “push-in/push-out” rotary level controls. This makes it easy to control the status of the microphone and talkback outputs as well as adjusting the signals that are sent to the headphone channels.

## Ethernet Data and PoE

The Model 208 connects to a local area network (LAN) by way of a standard 100 Mb/s twisted-pair Ethernet interface. The physical 100BASE-TX interconnection is made by way of a Neutrik® etherCON RJ45 connector. While compatible with standard RJ45 plugs, etherCON allows a ruggedized and locking interconnection for harsh or high-reliability environments. An LED displays the status of the network connection.

The Model 208’s operating power is provided by way of the Ethernet interface using the 802.3af Power-over-Ethernet (PoE) standard. This allows fast and efficient interconnection with the associated data network. To support PoE power management, the Model 208’s PoE interface reports to the power sourcing equipment (PSE) that it’s a class 1 (very low power) device. If a PoE-enabled Ethernet port can’t be provided by the associated Ethernet switch a low-cost PoE midspan power injector can be utilized.

## Dante Audio-over-Ethernet

Audio data is sent to and received from the Model 208 using the Dante audio-over-Ethernet media networking technology. As a Dante-compliant device, the Model 208’s two output (Dante transmitter) and two input (Dante receiver) audio channels can be assigned to other devices (routed) using the Dante Controller software application. The Dante transmitter and receiver channels are limited to supporting four Dante flows,

two in each direction. The digital audio’s bit depth is up to 24 with a sampling rate of 44.1, 48, 88.2, or 96 kHz. Two bi-color LEDs provide an indication of the Dante connection status. An additional LED displays the status of the associated Ethernet connection.

The Model 208 is compatible with the AES67 interoperability standard. In this mode the two transmitter (output) channels will function in multicast; unicast is not supported. In addition, the unit is compatible with the Dante Domain Manager™ (DDM) software application.

## Audio Quality

The Model 208’s audio performance is completely “pro.” A low-noise, wide dynamic-range microphone preamplifier and associated voltage-controlled-amplifier (VCA) dynamics controller (compressor) ensures that mic input audio quality is preserved while minimizing the chance of signal overload. The output of the microphone preamp and compressor is routed to an analog-to-digital conversion (ADC) section that supports sampling rates of 44.1, 48, 88.2, and 96 kHz with a bit depth of up to 24. The audio signal, now in the digital domain, routes through the processor and on to the Dante interface section where it is packetized and prepared for transport over Ethernet.

Audio input signals arrive via the Dante receiver channels and pass into the Model 208’s processor. The sampling rate will be 44.1, 48, 88.2, or 96 kHz with a bit depth of up to 24. Channel routing, headphone level control, and sidetone creation are performed within the digital domain. This provides flexibility, allows precise control, and keeps the three level potentiometers (two for audio inputs and one for sidetone) from having to directly handle analog audio

signals. The two audio channels destined for the phones outputs are sent to a high-performance digital-to-analog converter and then on to robust driver circuitry. High signal levels can be provided to a variety of headsets, headphones, and earpieces.

## Configuration Flexibility

The Model 208 can be configured to meet the needs of specific applications and user preferences. All configuration choices are performed using the STcontroller personal computer software application which is compatible with version 7 and later of the Windows operating systems. There are no mechanical switches settings or button-press sequences required to configure how the unit functions. Selectable parameters include microphone preamplifier gain, P48 phantom power on/off, button operation, headphone output mode, sidetone operation, and overall unit operation. The gain of the microphone preamplifier can be selected from among four choices. This allows the Model 208 to match the output sensitivity of a range of handheld and headset-associated microphones. A low-noise source of P48 phantom power can be enabled if required to support a variety of high-performance microphones.

The mic on/off and talkback pushbutton switches, located on the Model 208's front panel, can be individually configured. The mic on/off button can be selected to operate from among five modes while the talkback button can be selected from among three. These choices allow the Model 208's operation to be tailored to meet the specific needs of many applications. As an example, for on-air sports the mic on/off button would typically be configured to provide a push to mute (cough) function. The microphone signal would typically remain active

unless the talent needs to momentarily disable it. The talkback button would most likely be set in its push to talk mode as its use would be intermittent.

The headphone output mode can be configured from among four choices. The level/level mode is provided for broadcast applications where two channels of talent cueing ("IFB") need to be independently sent to the left and right headphone output channels. In on-air sports events it's typical for program audio with director interrupt to be sent to the left headphone output while program-only audio is sent to the right headphone output. The level/balance mode is intended for applications where a stereo signal is being routed to the Model 208's Dante inputs. In this mode the user is provided with one potentiometer to control the overall level of both headphone output channels and a second potentiometer to control the left/right level balance.

The dual-channel monaural mode allows the two Dante input audio channels to be summed (mixed together) and sent to both the left and right headphone output channels. Lastly, a unique single-channel monaural mode is provided for on-air talent cue applications where a single-channel earpiece or earbud is being used. The two Dante audio input channels are mixed and sent only to the left channel of the headphone output. No audio signal is present on the headphone output's right channel.

The integrated sidetone function can be configured from among four choices. This allows audio associated with the microphone input and microphone preamplifier to be returned to the headphone output. This is important as different applications may provide a "full mix" or a "mix-minus" talent cue signal. If a full mix cue signal is



provided then sidetone audio will not be needed and the function can be disabled. In the case where a mix-minus signal is present, providing the user with sidetone can be an important means of confirming the signal that's coming from the connected microphone.

The headphone gain range configuration helps to provide an optimized audio level to Model 208 users. The appropriate setting will depend on the specific audio sources provided to the unit as well as user preference.

Three system modes select the overall way in which the Model 208 functions. The on-air mode is optimized for applications where users will be on-air talent that must maintain strict separation between on-air and production audio channels. Other applications will benefit from the two available production modes.

## Future Capabilities and Firmware Updating

The Model 208 was designed so that its capabilities and performance can be enhanced in the future. A USB connector, located on the unit's main circuit board (underneath the unit's cover), allows the application firmware (embedded software) to be updated using a USB flash drive.

The Model 208 uses Audinate's Ultimo™ integrated circuit to implement the Dante interface. The firmware in this integrated circuit can be updated via the Ethernet connection, helping to ensure that its capabilities remain up to date.

# Getting Started

## What's Included

Included in the shipping carton are a Model 208 Announcer's Console and a printed copy of this guide. As a device that is Power-over-Ethernet (PoE) powered, no external power source is provided. Should a PoE midspan power injector be required it must be purchased separately. For mounting on a flat surface the optional bracket kit (Studio Technologies order code MBK-02) should be ordered.

## Connections

In this section signal interconnections will be made using the five connectors located on the back of the Model 208's enclosure. An Ethernet data connection with Power-over-Ethernet (PoE) capability will be made using either a standard RJ45 patch cable or an etherCON protected RJ45 plug. A microphone will be connected using a cable-mounted 3-pin male XLR connector. A set of headphones or an earpiece will be connected by way of a ¼-inch 2- or 3-conductor plug. If desired, the Model 208's microphone-level output may be interfaced with other equipment using a cable terminated with a standard 3-pin female XLR connector. Special applications may utilize the remote control inputs that are accessible using a 3.5 mm 3-conductor jack.

### Ethernet Connection with PoE

A 100BASE-TX Ethernet connection that supports Power-over-Ethernet (PoE) is required for Model 208 operation. This one connection will provide both the Ethernet data interface and power for the Model 208's circuitry. A 10BASE-T connection is not sufficient and a 1000BASE-T ("GigE") connection is not supported unless it can

automatically “fall back” to 100BASE-TX operation. The Model 208 supports Ethernet switch power management, enumerating itself as a PoE class 1 device.

The Ethernet connection is made by way of a Neutrik etherCON protected RJ45 connector that is located on the back of the Model 208's enclosure. This allows connection by way of a cable-mounted etherCON connector or a standard RJ45 plug. The Model 208's Ethernet interface supports auto MDI/MDI-X so that a “cross-over” or “reversing” cable will never be required.

### **Ethernet Connection without PoE**

As previously discussed in this guide, the Model 208 was designed such that the Ethernet connection will provide both data and Power-over-Ethernet (PoE) power. There may be situations where the associated Ethernet switch does not provide PoE power. In such cases an external PoE midspan power injector can be used. If the selected midspan power injector is 802.3af-compatible it should function correctly. Midspan units are available from a variety of sources, including many online retailers.

### **Microphone Input**

The Model 208 provides a 3-pin female XLR connector that allows a balanced dynamic or phantom powered condenser powered microphone to be connected. The microphone can be a standalone handheld (“stick”) type or can be part of a broadcast-style headset. The Model 208's microphone input is directly compatible with balanced dynamic or P48 phantom powered microphones. A microphone should be connected such that its associated XLR connector has pin 1 as common, pin 2 as signal high (+), and pin 3 as sign low (–). A configuration setting allows the P48 microphone power source to be enabled or

disabled as desired. Details on configuration settings will be described later in this guide.

While the Model 208 provides an excellent source of P48 phantom power, it's possible that an input that already provides microphone power will be connected to the unit's microphone output connector. This would not create a problem since the circuitry that connects audio from the Model 208's microphone output connector to the Model 208's microphone input connector will pass this microphone power through without interruption. This situation could be relevant when the Model 208's microphone output connector is interfaced with the microphone input on a broadcast camera, audio console, microphone mixer, or similar equipment. Inputs on these devices would typically offer phantom power which in some cases may have been enabled.

### **Headphone Output**

The Model 208 provides a 2-channel headphone output by way of a 3-conductor ¼-inch phone jack. Devices such as stereo headphones or stereo (“dual-muff”) broadcast-style headsets can be directly connected using a 3-conductor ¼-inch plug. Following the usual convention the left channel should be terminated on the tip lead, the right channel on the ring lead, and common on the sleeve lead.

It's also possible to use a monaural (“single-muff”) headset or broadcast-type single earbud but in these cases some care must be taken. If a 3-conductor ¼-inch plug is used by a device it should be wired to the tip and sleeve leads; the plug's ring lead should be left unconnected. But it's also possible that the monaural device will be terminated on a 2-conductor (“tip and sleeve”) plug. When the plug is inserted into the Model 208's headphone jack the Model 208's right

headphone output channel will be shorted; the ring lead will be directly connected to the sleeve lead. This can lead to stress on the right channel headphone output circuitry as well as extra current draw. To prevent this condition the headphone output mode configuration choice should be set for single-channel monaural. This disables the right headphone output channel and sends the listen audio sources only to the left output channel. Refer to the Configuration section later in this guide for details on setting the headphone audio routing.

### **Microphone Output**

A 3-pin male XLR connector provides a microphone-level output that's directly related to the microphone input. Technically the output is identical to the signal that's connected to the microphone input but with a solid-state muting circuit in series with the interconnection. When the Model 208's Dante main output channel is active the microphone signal will also pass through to the Model 208's microphone output. Whenever the Dante main output channel is muted the microphone signal does not pass through to the microphone output; it's muted in an essentially click-free manner. Refer to Appendix B for a block diagram of the microphone input and microphone output circuitry.

The microphone output can be connected to balanced (differential) analog microphone-level inputs on a variety of devices. This includes microphone input connections on remote I/O interfaces associated with a networked audio console. An example of such an interface would be the Calrec® Hydra2®. The mic inputs on these devices typically offer microphone power, high-quality amplification, and conversion to the digital domain. The output signals

of the interface's pre-amp channels are transported to the main electronics or console surface using a fiber optic interface. In this type of application the Model 208's Dante main output channel would not be used or would only be used as a backup path.

No preamplifier or other active circuitry impacts the path from the Model 208's microphone input connector to the Model 208's microphone output connector. The signal does pass through a 200 ohm resistor in each "leg" (pin 2 and pin 3) along with connecting to a solid-state relay contact. The result is that the source impedance of a connected microphone will be 400 ohms greater when presented to the microphone output connector. This will slightly raise the theoretical noise floor of the microphone signal vis-a-vis a directly connected microphone signal but shouldn't impact any real-world applications.

### **Remote Control Inputs**

Provision has been made to allow external switches or contact closures to mimic operation of the mic on/off and talkback pushbutton switches. These in turn control the status of the audio signal sent to the main and talkback Dante output channels as well as the microphone output connector. A 3.5 mm 3-conductor jack is located on the back panel and provides access to the remote control inputs. The input circuitry is "active low," with 3.4 k ohm resistors connected to +3.3 volts DC to act as input "pull ups." (In addition a combination of resistors and capacitors provide ESD protection, minimizing the chance of damage due to static discharge or other extraneous signals.) A current flow of less than one milliampere is required for a remote control input to be recognized as active.

Prepare the interconnecting cable and associated 3.5 mm 3-conductor plug to reflect that the tip lead is used to control the microphone on/off function, the ring lead is used to control the talkback function, and the sleeve lead is the connection to common.

## Securing the Unit to a Surface

The Model 208 can be mounted to the top or bottom (under) side of a flat surface using the Studio Technologies MBK-02 bracket kit. The kit, purchased as an option, contains two brackets, four 6-32 x 3/8-inch screws, and four #6 lock washers. Refer to Appendix A for details.

Begin by removing the two screws and associated lock washers that secure the cover to one side of the chassis. A 5/64-inch hex driver is required to remove the screws. Save the screws and the lock washers. Using the 6-32 x 3/8-inch screws that are included with the bracket kit, along with the lock washers that were just removed, attach one of the brackets to the applicable side of the enclosure. If either or both lock washers are misplaced use ones that are provided in the MBK-02 kit.

The bracket can be mounted so that its mounting flange faces down or faces up, allowing the Model 208 to be attached to the top side or the bottom (under) side of a surface. Repeat the process on the other side of the enclosure for the second bracket. If possible, save the four standard 6-32 x 1/4-inch screws and four lock washers for future re-use if the brackets are ever removed. Review the installation of the brackets to ensure that they are both in their desired orientation.

## Dante Configuration

For audio to pass to and from the Model 208 requires that several Dante-related

parameters be configured. These configuration settings will be stored in non-volatile memory within the Model 208's circuitry. Configuration will typically be done with the Dante Controller software application which is available for download free of charge at [www.audinate.com](http://www.audinate.com). Versions of Dante Controller are available to support Windows and OS X® operating systems. The Model 208 uses the Ultimo 2-input/2-output integrated circuit to implement the Dante architecture.

The two Dante transmitter (Tx) channels associated with the Model 208's Dante interface must be assigned to the desired receiver channels. This achieves routing the Model 208's two output audio channels to the device (or devices) that will be "listening" to them. Within Dante Controller a "subscription" is the term used for routing a transmitter flow (a group of output channels) to a receiver flow (a group of input channels). The number of transmitter flows associated with an Ultimo integrated circuit is limited to two. These can either be unicast, multicast, or a combination of the two. If the Model 208's transmitter channels need to be routed to more than two flows it's possible that an intermediary device with enhanced flow capability, such as the Studio Technologies Model 5422 Dante Intercom Audio Engine, can be used to "repeat" the signals.

The two Dante receiver (Rx) channels associated with the Model 208's audio inputs also need to be routed to the desired Dante transmitter channels. These two audio signals will be sent to the Model 208's 2-channel headphone output.

The Model 208 supports audio sample rates of 44.1, 48, 88.2, and 96 kHz with no pull-up/pull-down values available.

In most cases it's anticipated that the default rate of 48 KHz will be appropriate. While technically the Model 208 can serve as a clock master for a Dante network (as can all Dante-enabled devices) in virtually all cases the unit will be configured to receive "sync" from another device.

The Model 208 has a default Dante device name of **ST-M208** along with a unique suffix. The suffix identifies the specific Model 208 that is being configured. The suffix's actual alpha and/or numeric characters relate to the MAC address of the unit's Ultimo integrated circuit. The two Dante transmitter (Tx) channels have default names of **Main** and **Talkback**. The two Dante receiver (Rx) channels have default names of **Headphone Ch1** and **Headphone Ch2**. Using Dante Controller the default device name and channel names can be revised as appropriate for the specific application.

## Model 208 Configuration

The STcontroller software application is used to configure the way in which the Model 208 functions. No DIP switch settings or other local actions are used to configure the unit. This makes it imperative that STcontroller be available for convenient use in a personal computer that's connected to the related LAN.

The configurable functions include:

- P48 phantom power on/off status
- Microphone preamplifier gain
- Headphone output and sidetone modes, gain range, and minimum level
- Mic on/off and talkback button modes
- System mode

Changes made using STcontroller will be immediately reflected in the unit's operation. No Model 208 "reboot" is required. Each time a change is made the mic on/off and talkback buttons on the front panel will momentarily flash orange to indicate that a command from STcontroller has been received.

## Installing STcontroller

STcontroller is available free of charge on the Studio Technologies website ([www.studio-tech.com/stcontroller](http://www.studio-tech.com/stcontroller)) and is compatible with personal computers running Windows operating systems that are version 7 and later. STcontroller versions 1.02.00 and later will fully support the Model 208. If required, download and install STcontroller onto a designated personal computer. This personal computer must be on the same local area network (LAN) and subnet as the Model 208 unit or units that are to be configured. Immediately after starting STcontroller the application will locate the devices that it can control. The Model 208 unit or units will appear in the device list. Use the identify command to allow easy recognition of a specific Model 208 unit. Double-clicking on a device name will cause the associated configuration menu to appear. Review the current configuration and make changes as required.

## P48 Phantom Power

STcontroller allows selection of the on/off status of the microphone input's P48 phantom power source. The on/off status is displayed by way of an LED, red in color, located on the back panel adjacent to the microphone input connector. Select the status of the P48 source to meet the needs of the connected microphone. No problem will occur if an external source of P12 or P48 phantom power is present on

the connection made to the microphone output connector. In this case simply turn off the Model 208's P48 phantom power source. The external source of microphone power will "pass thru" from the microphone output connector to the microphone input connector.

### **Microphone Preamp Gain**

The gain of the Model 208's microphone preamplifier can be selected from among four choices: 35, 43, 52, and 59 dB. The compressor active LED, orange in color and visible on the back of the Model 208's enclosure adjacent to the microphone input connector, can act as a guide when setting the preamp gain. When a voice signal at a normal level is present on the microphone input the compressor active LED should light intermittently. If, for example, it rarely lights and the gain is set to 43 dB, it might be a good idea to change the setting to 52 dB. If the LED is lit fully during normal talking and the gain is set for 52 or 59 dB, changing it to one of the lower values might be warranted. There's no "hard and fast" rule about which gain setting is appropriate. But unless otherwise indicated, 43 dB is typically a good initial choice.

### **Headphone Output Mode**

STcontroller allows selection from among four headphone output modes. Each mode is distinct and careful selection will help optimize the Model 208's operation for a range of applications.

#### ***Level/Level***

The level/level mode is provided for on-air applications where two independent audio sources need to be routed to separate headphone output channels. Dante audio input channel 1 will be routed to the left headphone output channel and the

front-panel left phones potentiometer will adjust its level. Dante audio input channel 2 will be routed to the right headphone output channel and the right phones potentiometer will adjust its level.

#### ***Level/Balance***

The level/balance mode is provided for stereo applications such as live music events that are distributed via streaming or broadcast radio. In these applications it's typical to want the user to have a single control to simultaneously adjust the level of both channels while a separate control is used to adjust the left/right level balance.

When set for the level/balance mode Dante input channel 1 will be routed to the left headphone output channel and Dante input channel 2 will be routed to the right headphone output channel. The left phones potentiometer will adjust the overall level of both headphone output channels. The right phones potentiometer will adjust the level balance between the left and right output channels.

#### ***Dual-Channel Monaural***

The dual-channel monaural mode can be useful in applications where the same audio signals need to be provided to the user on both the left and right headphone output channels. In this mode Dante audio inputs 1 and 2 are combined (mixed together or "summed") and routed to both the left and right channels of the headphone output. The left phones potentiometer adjusts the level of Dante audio input 1 and the right phones potentiometer adjusts the level of Dante audio input 2.

#### ***Single-Channel Monaural***

The single-channel monaural mode is specifically provided for applications where a 2-conductor ¼-inch plug is being used

with the connected headphones, headset, or a broadcast-style earpiece. In this mode Dante audio inputs 1 and 2 are combined to monaural and routed to only the left channel of the headphone output; no audio signal is routed to the right channel of the headphone output. The left phones potentiometer adjusts the level of Dante audio input 1 and the right phones potentiometer adjusts the level of Dante audio input 2.

### **Headphone Gain Range**

The overall level of the headphone output can be configured as desired for specific applications. The default setting, low, is designed so that users with typical audio input sources will be inclined to set the rotary controls at approximately 50% of rotation. This would be appropriate for most applications. The high setting would be applicable in cases where an extreme headphone output level is required or the audio input sources are providing a level that is lower than typical. Using the high setting in the former application is not recommended as hearing damage could result from exposure to high signal levels.

### **Headphone Minimum Level**

A setting in STcontroller is used to configure the headphone output's minimum level. In the -40 dB setting the minimum headphone output level is approximately 40 dB below its maximum; the headphone output will never fully mute. This ensures that any audio signal present on either of the Dante audio input channels will always be present on the headphone output. In most on-air broadcast applications this is the appropriate setting, ensuring that a minimum amount of signal is always present. When full mute is selected moving either level control to its fully counterclockwise position will cause its associated

headphone output channel (or channels) to fully mute. If a rotary level control is set to serve as a balance control, moving it to either its fully counterclockwise or fully clockwise position will cause the associated signal to fully mute. Selecting the full mute mode may be appropriate for applications where minimizing the chance of audio "leakage" is important. This could occur when the connected headset or headphones are at times placed on a desk or tabletop.

Note that the rotary level control, located on the far right side of the front panel, controls the sidetone level and the setting of the headphone minimum level will not impact it. Whenever the sidetone control is in its fully counterclockwise position it will always cause the sidetone audio signal being sent to the headphone output channels to be fully muted.

### **Sidetone Mode**

STcontroller allows the Model 208's sidetone function to be configured as desired. Sidetone is audio from the microphone input that is sent to the headphone output channels. This can be important, allowing the user to "hear" themselves for performance confirmation and comfort. Making a specific selection from among the four available modes will depend on the needs of the application. If a "full mix" is being provided to the Model 208's audio inputs then locally provided sidetone won't be needed. The user will hear themselves by way of the audio signals being routed to the Dante audio input channels. But if a "mix-minus" is being supplied to the Model 208 then having one of the sidetone modes enabled can be an important means of establishing user confidence.

Four sidetone modes are available:

- **Off:** In this mode the sidetone function is not active.
- **Mic On/Off Button:** In this mode the sidetone function will be active whenever the audio signal associated with the mic input is present on the Dante main output channel and the microphone output connector.
- **Talkback Button:** In this mode the sidetone function will be active whenever the talkback function is active and the audio signal is present on the Dante talkback output channel.
- **Mic On/Off and Talkback Buttons:** In this mode the sidetone function will be active whenever the audio signal associated with the mic input is present on the Dante main output channel and the microphone output connector. The sidetone function will also be active whenever the talkback function is active.

### **Mic On/Off Button**

STcontroller allows the configuration of the mic on/off button to be selected. There are five mode choices available:

- **Push to Mute:** If this mode is selected the mic on/off function will normally be active and its green LED lit. The audio signal associated with the microphone input will be routed to both the Dante main output channel and the microphone output connector. Whenever the button is pressed the audio signal will mute on both the Dante main output channel and the microphone output connector; the LED on the button will no longer be lit.
- **Push to Talk:** If this mode is selected the mic on/off function will normally be inactive and the button LED not lit. The audio signal associated with the microphone input will not be routed to the Dante main output channel and the microphone output connector will be muted. Whenever the mic on/off button is pressed the audio signal will become active on the Dante main output channel and the microphone output connector. In addition, the button LED will light.
- **Latching:** If this mode is selected the mic on/off function will alternate between its on (active) and off (inactive) states whenever the button is pressed. Upon power up the function will be in its off state and the LED on the button will not be lit.
- **Push to Talk/Tap to Latch:** This mode is a combination of the Push to Talk and Latching modes. It's similar to the way talk pushbutton switches function on user stations associated with broadcast or production intercom systems. If the button is pressed and held the mic on/off button function will be on. It will stay active until the button is released. If the mic on/off button is momentarily "tapped" the mic on/off status will change, either from off-to-on or from on-to-off. Upon Model 208 power up the mic on/off button will be in its off state and its LED will not be lit.
- **Push to Mute/Tap to Latch:** This mode is a combination of the Push to Mute and Latching modes. Whenever the mic on/off button is momentarily "tapped" the mic on/off button's status will change, either from active-to-inactive or inactive-to-active. When the mic on/off button function is active its green LED will be lit. The audio signal associated with the microphone input will be routed to both the Dante main output channel and



the microphone output connector. Whenever the mic on/off button is pressed and held the audio signal will mute on both the Dante main output channel and the microphone output connector and the button's LED will no longer light. It will stay in this condition until the mic on/off button is released. Upon Model 208 power up the mic on/off button will be in its inactive state and its LED will not be lit.

### **Talkback Button Mode**

The manner in which the talkback button functions can be configured. There are three mode choices available:

- **Push to Talk:** If this mode is selected the talkback function will normally be inactive and the button LED not lit. Whenever the button is pressed the talkback function will become active and the button LED will light.
- **Latching:** If this mode is selected the talkback function will alternate between its on (active) and off (inactive) states whenever the button is pressed. Upon power up the function will be in its off state and the button LED will not be lit.
- **Push to Talk/Tap to Latch:** This mode is a combination of the Push to Talk and Latching modes. It's similar to the way talk pushbutton switches function on user stations associated with broadcast or production intercom systems. If the talkback button is pressed and held the talkback function will be on (active). It will stay active until the button is released. If the talkback button is momentarily "tapped" the status of the talkback function will change, either off-to-on or on-to-off. Upon Model 208 power up the talkback button will be in its off state and its LED will not be lit.

### **System Mode**

The system mode configures the overall manner in which the Model 208 operates. Specifically, it determines how the Dante main output channel and the microphone output connector operate vis-à-vis the talkback function. The system mode can also impact one facet of the headphone output's function. There are three system modes available. Understanding how each specifically impacts Model 208 operation will help to ensure that the desired operation is obtained and that maximum usability will occur.

#### ***On-Air***

When selected to the on-air mode, audio on the Dante main output channel and the microphone output connector will always mute whenever the talkback function is active. The on-air mode should be selected for all on-air broadcast applications when it's imperative that the "on-air" audio signal be muted whenever on-air talent uses the talkback function to communicate with production personnel.

#### ***Production***

When the system mode is set for production, the audio signals on the Dante main output channel and microphone output connector are never muted in response to talkback function activity. The mic off/off function operates independently of the talkback function. This mode allows the Dante main output channel to be used, for example, as an additional talkback output. In this way the Dante main and talkback output channels can be used separately, with neither impacting the other. This also allows both the mic on/off and talkback pushbuttons to be used simultaneously. When selected for the correct application,

the production mode can prove to be very useful. But it's not appropriate for on-air use!

### ***Production with Dim***

This mode is identical to the production mode with the exception that the headphone output reduces in level (“dims”) whenever the mic on/off or talkback functions are active. This mode was specifically provided to minimize the chance that acoustical feedback will occur in applications where the headphone output is connected to the inputs on amplified speakers. (Or inputs on an amplifier associated with loudspeakers.) In this mode the level of the headphone output channels is reduced by 18 dB whenever the mic on/off or talkback functions are active. This mode is not appropriate when headphones are going to be connected to the Model 208!

## **Operation**

At this point all connections and configuration steps should have been completed and everything should be ready for Model 208 operation to commence. An Ethernet connection with Power-over-Ethernet (PoE) capability should have been made. Alternately, a midspan power injector, in “series” with the Ethernet connection, should have been put into place. A microphone and headphones or earbud should have been connected. Alternately, a broadcast-style headset should be connected. If desired, a connection to the microphone output should have been made. Special applications may utilize either or both of the remote control inputs.

The Model 208 should have been placed in the desired physical location. This may involve securing the unit to a fixed location using the optional mounting brackets. Using the Studio Technologies STcontroller software application the unit's configuration should have been set to meet the needs of the specific application. The Model 208's Dante configuration settings should have been selected using the Dante Controller software application. In this way the unit's two audio output channels (Dante transmitter channels) and two audio input channels (Dante receiver channels) should have been routed to the receiver and transmitter channels on associated equipment.

### **Initial Operation**

The Model 208 will start to function as soon as a Power-over-Ethernet (PoE) power source is connected. However, it may take 20 to 30 seconds for full operation to commence. Upon initial power up the three status LEDs, located on the back panel below the RJ45 jack, will begin to light as network and Dante connections are established. The COMP LED, adjacent to the microphone input connector, may or may not flash momentarily. The P48 LED, also located adjacent to the microphone input connector, will flash once to indicate that it is functioning. The green and orange LEDs within the mic on/off and talkback pushbutton switch will light in a short test sequence to indicate that the application firmware (embedded software) has started. Once that sequence has completed and the Dante connection has been established full operation will begin. The various LEDs will then become operational, displaying the status of their designated functions.

## How to Identify a Specific Model 208

Functions within the Dante Controller and STcontroller software applications allow a specific Model 208 unit to be identified. Each application provides an “eyeball” icon that when clicked will activate the identify function. When identify is selected it will send a command to a specific Model 208 unit. On that unit the orange LEDs associated with the mic on/off and talkback pushbutton switches will flash on and off approximately eight times. (The on/off status of the buttons will not change.) In addition, the SYS and SYNC status LEDs, located directly below the etherCON RJ45 connector on the back panel, will slowly flash green. After a few seconds the LED identification pattern will cease and normal Model 208 button LED and Dante status LED operation will resume.

## Ethernet and Dante Status LEDs

Three status LEDs are located below the etherCON RJ45 connector on the Model 208's back panel. The LINK ACT LED will light green whenever an active connection to a 100 Mb/s Ethernet network has been established. It will flash in response to Ethernet data packet activity. The SYS and SYNC LEDs display the operating status of the Dante interface and its associated network activity. The SYS LED will light red upon Model 208 power up to indicate that the Dante interface is not ready. After a short interval it will light green to indicate that it is ready to pass data with another Dante device. The SYNC LED will light red when the Model 208 is not synchronized with a Dante network. It will light solid green when the Model 208 is synchronized with a Dante network and an external

clock source (timing reference) is being received. It will slowly flash green when this specific Model 208 is part of a Dante network and is serving as the clock master. It's possible that up to 30 seconds may be required for the SYNC LED to reach its final state.

## P48 Status LED

A red LED indicator is located on the back panel adjacent to the microphone input connector. It is labeled P48 and will light whenever the P48 phantom power source is active and providing power to the microphone input.

## Compressor Active LED and Mic Preamp Gain

An orange LED indicator is located on the back panel, also adjacent to the microphone input connector. It is labeled COMP and displays the status of the microphone audio compressor function. This function controls the dynamic range of the audio signal that can be present on the Dante output (transmitter) channels and side-tone audio sent to the headphone output versus the signal present on the microphone input. The compressor LED will light whenever the input level from the microphone, along with the configured mic preamp gain, is such that the dynamic range of the signal is being actively controlled. It's perfectly acceptable for this LED to light intermittently whenever a user is talking at a normal voice level into an associated microphone. But if the COMP LED lights solid while a user is talking at a normal voice level this will typically indicate that the mic gain setting should be reduced. Conversely, if the COMP LED almost never lights when normal talking is taking place, it's possible that changing the

gain to a higher value would be beneficial. Note that due to the design of the circuitry the compressor active LED will function whether or not the main or talkback functions are active. Also, the compressor function does not impact the microphone output connector.

## Microphone On/Off and Talkback Buttons

Two pushbutton switches are used to select how the microphone signal is routed to the two Dante output channels and the microphone output connector. The button labeled MIC ON/OFF controls if the audio signal associated with the microphone input will be present on the Dante main output channel and the microphone output connector on the back panel of the Model 208. How the button functions will depend on the configuration choice that has been made using STcontroller. When the mic on/off button's green LED is lit audio will be present on both the Dante main output channel and the microphone output connector. When the mic on/off button's LED is not lit audio will not be present on the Dante main output channel and the audio signal associated with the microphone output connector will be muted.

The talkback function allows the audio associated with the microphone input to be routed to the Dante talkback output channel. When the talkback button's green LED is lit the talkback function will be active. When the talkback button's LED is not lit the talkback function is not active. How the talkback button will specifically function and whether it impacts the microphone on/off function will depend on the configuration of the Model 208.

## Mic On/Off Button Modes

There are five ways that the mic on/off pushbutton can function. A specific Model 208 unit's operating mode will depend on its selected configuration.

- **Push to Mute:** If this mode is selected the audio signal associated with the microphone input will normally be active on the Dante main output channel and the microphone output connector. The audio signal will mute whenever the mic on/off pushbutton is pressed and held.
- **Push to Talk:** If this mode is selected the audio signal associated with the Dante main output channel and the microphone output connector will be normally muted. The audio signal will become active whenever the mic on/off pushbutton is pressed and held.
- **Latching:** If this mode is selected the audio signal associated with the Dante main output channel and the microphone output connector will alternate between the active and muted states whenever the mic on/off pushbutton is pressed. Upon Model 208 power up the audio signal will be in its muted state.
- **Push to Talk/Tap to Latch:** This mode is a combination of the Push to Talk and Latching actions. It's similar to the way in which talk pushbuttons function on user stations associated with broadcast or production intercom systems. If the mic on/off pushbutton is pressed and held the audio signal associated with the Dante main output channel and the microphone output connector will become active and remain active until the pushbutton is released. If the mic on/off pushbutton is momentarily "tapped" the audio signal will change state. Upon Model 208 power up the audio signal will be in its muted state.

- **Push to Mute/Tap to Latch:** This mode is a combination of the Push to Mute and Latching modes. Whenever the mic on/off button is momentarily “tapped” its status will alternate between active and muted. When the mic on/off button’s function is active and the mic on/off button is pressed and held the audio signal will mute on both the Dante main output channel and the microphone output connector. It will stay in this condition until the mic on/off button is released. Upon Model 208 power up the mic on/off button will be in its muted state.

### **Talkback Button Modes**

Depending on the selected configuration, the talkback pushbutton will function in one of three possible modes:

- **Push to Talk:** If this mode is selected the audio signal associated with the Dante talkback output channel is normally muted. The audio signal will become active whenever the talkback pushbutton is pressed and held.
- **Latching:** If this mode is selected the audio signal associated with the Dante talkback output channel will alternate between its active and muted states whenever the talkback pushbutton is pressed. Upon Model 208 power up the Dante talkback output channel will be in its muted state.
- **Push to Talk/Tap to Latch:** This mode is a combination of the Push to Talk and Latching actions. If the talkback pushbutton is pressed and held the audio signal associated with the Dante talkback output channel will become active until the pushbutton is released. If the talkback pushbutton is momentarily “tapped” the audio signal on the Dante talkback

output channel will change state. Upon Model 208 power up the audio signal on the Dante talkback output channel will be in its muted state.

### **Remote Control Inputs**

The Model 208 allows two external contacts to be connected to the remote control inputs. Whether or not they are utilized will depend on the selected application. If either or both are utilized they will provide an action identical to that caused by pressing or tapping the mic on/off and talkback pushbutton switches. How they specifically function will depend on how the buttons are configured. For example, if the mic on/off button is configured for latching mode the mic on/off remote control input will provide the same action as would utilizing the mechanical pushbutton switch.

### **System Mode**

The system mode configuration is used to select the overall operating mode of the Model 208. Specifically, the system mode determines how the mic on/off function operates vis-à-vis the talkback function as well as if the level of the headphone output is impacted by pushbutton activity. Understanding how the three system modes impact overall system operation will ensure correct operation and maximum usability.

- **On-Air:** When the system mode has been selected to on-air the mic on/off function will be forced off whenever the talkback function is active. The on-air mode will be appropriate for all on-air broadcast applications where it’s imperative that the audio signal on the Dante main output channel and microphone output connector be muted whenever on-air talent uses the talkback function to communicate with production personnel.

- **Production:** When set for the production mode the status of the mic on/off function will never be impacted by the status of the talkback function. This mode allows the Dante main output channel to be used, for example, as an additional talkback output. In this way the Dante main and talkback output channels can be used independently, with activation of either never impacting the other. This also allows both pushbuttons to be used simultaneously. When selected for the correct application, the production mode can prove to be very useful. But it's not appropriate for on-air use!
- **Production with Dim:** This mode functions exactly as the production mode does with one addition. The level of the headphone output is dimmed (reduced in level or attenuated) by 18 dB whenever the main on/off or talkback functions are active. In this way the headphone output can be connected to amplified loudspeakers without the risk of acoustical feedback. The selection of this mode will be clearly evident as speakers (or a connected set of headphones) will automatically reduce in level whenever the mic on/off or talkback functions is active.

## Headphone Output

Three rotary potentiometers (pots), located on the Model 208's front panel, allow adjustment of the level of the two Dante audio input channels and the sidetone (local microphone) audio signal as they are sent to the 2-channel headphone output. How the pots function will depend on the selected configuration. Four output modes are available and determine the overall performance. The sidetone mode determines how the sidetone function, and its associated level control, will operate. The

gain range configuration allows the overall output level to be selected. The minimum level configuration will determine what occurs when the pots are in their fully counterclockwise position.

Users should find the headphone audio quality to be excellent, with high maximum output level and low distortion. Analog audio signals do not pass directly through the level pots. The position of each pot is recognized by the Model 208's processor which then adjusts the appropriate signal level within the digital domain. The pots are "push-in/push-out" type which allow their associated knobs to be in their "out" position when adjustment is desired and their "in" position when protection from an unwanted change is beneficial.

### Output Mode

Four output modes allow the overall headphone output performance to be configured:

- **Level/Level:** In this mode the left phones pot will control the level of Dante input 1 as it is being sent to the left channel of the headphone output. The right phones pot will control the level of Dante input 2 as it is sent to the right output.
- **Level/Balance:** In the level/balance mode Dante input 1 will be sent to the left channel headphone output while Dante input 2 will be sent to the right channel of the headphone output. The left phones pot will adjust the level of both the left and right headphone outputs. The right phones pot will control the left/right level balance of the headphone output.
- **Dual-Channel Monaural:** When this mode is selected the left phones pot will adjust the level of Dante input 1

as it is routed to both the left and right headphone output channels. The right phones pot will adjust the level of Dante input 2 as it is sent to both the left and right headphone outputs.

- **Single-Channel Monaural:** When the Model 208 has been configured for the single-channel monaural mode the left phones pot adjusts the level of Dante input 1 as it is routed to the left channel of the headphone output. The right phones pot will adjust the level of Dante input 2 as it is also routed to the left headphone output channel; no audio is sent to the right headphone output channel.

### **Sidetone**

The Model 208 includes a sidetone function that allows microphone audio (electrically following the microphone preamplifier) to be sent to the headphone output. The sidetone function can be configured to operate from among four choices.

- **Off:** When configured to the off mode no microphone audio will be sent to either of the headphone output channels. In this mode the sidetone function is fully disabled.
- **Mic On/Off Button:** When configured for this mode the sidetone function will be active whenever microphone audio is actively being sent to the Dante main output channel and the microphone output connector. When the mic on/off function is not active no sidetone audio will be sent to the phones output.
- **Talkback Button:** When the mode is configured for talkback button the sidetone function will be active whenever the talkback function is active.

- **Mic & Talkback Buttons:** When configured for this mode the sidetone function will be active whenever either the mic on/off or talkback functions are active.

Sidetone audio quality will be excellent and can provide a Model 208 user with a confidence signal whenever their microphone is “active” but their talent cue signal doesn’t return their own voice audio. This can be important in cases where “mix-minus” cue signals are being provided to the user by way of the Dante audio inputs.

Whether sidetone audio will be sent to the left and right headphone output channels or only the left headphone output channel will depend on the configuration of the headphone output mode. As expected, should the headphone output mode be configured for level/level, level/balance, or dual-channel monaural, sidetone audio will be sent to both the left and right headphone output channels. When configured for single-channel monaural, sidetone audio will be sent only to the left headphone output channel.

### **Gain Range**

A configuration setting allows the overall headphone output gain range to be selected. The low setting is appropriate for most where users who need to listen to the headphone output at a moderate level. The high setting can be useful when monitoring at higher levels is warranted by an application. Alternately, the high setting can be useful for applications where the audio source is very low in level and the extra gain can bring the signal up to a useful listening condition. For example, in golf broadcast applications on-air talent frequently has to speak at a very low level so as to not interfere with participants.

## Minimum Level

How the headphone output channels function when a pot is in its fully counterclockwise position will depend on the configuration of the minimum level function. Also, when the headphone output mode is selected for the level/balance mode the minimum level configuration setting will determine what happens when the balance pot is set to either its fully counterclockwise or fully clockwise positions. Two selections are available:

- **Full Mute:** When the minimum level configuration is set for full mute turning a pot to its fully counterclockwise position will cause the associated audio signal to be fully muted. So, as an example, in the level/balance mode turning the left headphone output level control fully counterclockwise will cause the audio associated with Dante input channel 1 to mute and not be sent to the left headphone output. And in the case where the level/balance mode has been selected turning the balance control to either end of its travel will cause the applicable channel to fully mute.
- **-40 dB:** When configured for this mode the maximum attenuation of an audio signal when sent to a headphone output channel is 40 dB below its maximum. This mode is provided for applications where important cue signals never should be fully muted. In live television or streaming events this can be particularly useful. This can ensure that producer or director cues will always be heard, even if at a greatly reduced level. It can be important to alert users that this configuration has been selected. Otherwise they can mistake the low level of audio present on the headphone output to be audio "leakage" or "crosstalk" situation.

# Technical Notes

## IP Address Assignment

By default the Model 208's Ethernet interface will attempt to automatically obtain an IP address and associated settings using DHCP (Dynamic Host Configuration Protocol). If a DHCP server is not detected an IP address will automatically be assigned using the link-local protocol. This protocol is known in the Microsoft® world as Automatic Private IP Addressing (APIPA). It is also sometimes referred to as auto-IP (PIPPA). Link-local will randomly assign a unique IP address in the IPv4 range of 169.254.0.1 to 169.254.255.254. In this way multiple Dante-enabled devices can be connected together and automatically function, whether or not a DHCP server is active on the LAN. Even two Dante-enabled devices that are directly interconnected using an RJ45 patch cord will, in many cases, correctly acquire IP addresses and be able to communicate with each other.

An exception does arise when trying to directly interconnect two Dante-enabled devices that use Ultimo integrated circuits to implement Dante. The Model 208 uses Ultimo and, as such, a direct one-to-one interconnection to another Ultimo-based product is not supported. An Ethernet switch linking the two units is required to successfully interconnect two Ultimo-based devices. The technical reason that a switch is required relates to the need for a slight latency (delay) in the data flow; an Ethernet switch will provide this.

Using the Dante Controller software application the Model 208's IP address and related network parameters can be set for a fixed (static) configuration. While



this is a more involved process than simply letting DHCP or link-local “do their thing,” if fixed addressing is necessary then this capability is available. But in this case it’s highly recommended that every unit be physically marked, e.g., directly using a permanent marker or “console tape,” with its specific static IP address. If knowledge of a Model 208’s IP address has been misplaced there is no reset button or other method to easily restore the unit to a default IP setting.

In the unfortunate event that a specific Model 208’s IP address is “lost,” the Address Resolution Protocol (ARP) networking command can be used to “probe” devices on a network for this information. For example, in Windows OS the **arp -a** command can be used to display a list of LAN information that includes MAC addresses and corresponding IP addresses. The simplest means of identifying an unknown IP address is to create a “mini” LAN with a small PoE-enabled Ethernet switch connecting a personal computer to the Model 208. Then by using the appropriate ARP command the required “clues” can be obtained.

## Optimizing Network Performance

For best Dante audio-over-Ethernet performance a network that supports VoIP QoS (voice-over-internet-protocol quality of service) capability is recommended. This can typically be implemented on virtually all contemporary managed Ethernet switches. There are even specialized switches that are optimized for entertainment-associated applications. Refer to the Audinate website ([www.audinate.com](http://www.audinate.com)) for details on optimizing networks for Dante applications.

## Application Firmware Version Display

There are two ways in which the version number of the Model 208’s application firmware (embedded software) can be identified. One requires only the Model 208 unit and involves a button press sequence performed upon power up. The other method utilizes the Model 208 and the STcontroller software application. Either method may prove to be useful when working with factory personnel on application support and troubleshooting.

As part of the Model 208’s power-up sequence the unit’s application firmware can be directly displayed. Before connecting the PoE-enabled Ethernet cable, press and hold the talkback button. Then connect the Ethernet cable. Upon application of PoE power the Model 208 will not go through its normal power-up sequence but instead will display the firmware version. The LED associated with the mic on/off button will “flash” green in color to display the major version number and then “flash” orange to display the minor version number. Then the LED will remain off until the talkback button is released. Once the talkback button is released normal operation will then take place. As an example of what would be a typical firmware display, if the mic on/off button’s LED “flashes” green once followed by the LED “flashing” orange once it would indicate that application firmware version 1.1 is present in the Model 208.

A selection in the STcontroller software application allows the Model 208’s application firmware version to be identified. Connect the Model 208 unit to the network and let it connect and start to function. Then, after starting STcontroller, review

the list of identified devices and select the specific Model 208 from which you want to determine its application firmware version. Then select Version under the Device tab. A page will then display that will provide lots of useful information. This includes the application firmware version and well as details on the Dante interface firmware.

## Application Firmware Update Procedure

It's possible that updated versions of the application firmware (embedded software) that is utilized by the Model 208's processor (microcontroller or MCU) integrated circuit will be released to add features or correct issues. Refer to the Studio Technologies website for the latest application firmware file. The unit has the ability to load a revised file into the MCU's non-volatile memory by way of a USB interface. The Model 208 implements a USB host function that directly supports connection of a USB flash drive. The Model 208's MCU updates its firmware using a file named **m208.bin**.

The update process begins by preparing a USB flash drive. The flash drive doesn't have to be empty (blank) but must be in the personal-computer-standard FAT32 format. Save the new firmware file in the root directory with a name of **m208.bin**. Studio Technologies will supply the application firmware file inside a .zip archive file. While the firmware file inside of the zip file will adhere to the naming convention required by the Model 208, the name of the zip file itself will include the file's version number. For example, a file named **m208v1r1MCU.zip** would indicate that version 1.1 of the application firmware (**m208.bin**) is contained within this zip file.

Once the USB flash drive is inserted into the USB interface, located on the main circuit board under the cover, the unit must be powered off and again powered on. At this point the file will automatically load. The precise steps required will be highlighted in the next paragraphs of this guide.

To install an application firmware file follow these steps:

1. Disconnect power from the Model 208. This will entail removing the Ethernet connection that is providing PoE power.
2. Remove the cover from the Model 208. Begin by removing the four hex head machine screws, two per side, using a 5/64-inch hex driver. Be certain to save the screws and associated lock washers so that re-assembly will be fast and painless. Then carefully slide the cover forward, lifting it off once it has cleared away from the level controls and buttons.
3. Locate the USB connector on the main circuit board. It's near the front of the unit, directly between the channel 1 and channel 2 rotary level controls. Insert the prepared USB flash drive into the connector.
4. Apply power to the Model 208 by connecting to a Power-over-Ethernet (PoE) Ethernet source.
5. After a few seconds the Model 208 will run a "boot loader" program that will automatically load the new application firmware file (**m208.bin**). This loading process will take only a few seconds. During this time period the mic on/off button LED will flash slowly in alternating colors. Once the entire loading

process is over, taking approximately 10 seconds, the Model 208 will restart using the newly-loaded application firmware.

6. At this time the Model 208 is functioning with the newly-loaded application firmware and the USB flash drive can be removed. But to be conservative, remove PoE power first and then remove the USB flash drive.
7. Confirm that the desired firmware version has been correctly loaded. This can be done by pressing and holding the talkback button, applying power to the Model 208, and then “reading” the application firmware version number by observing the mic on/off button’s LED. Alternately, the STcontroller application can be used to identify the application firmware version number. Whatever method you use, ensure that the desired version is present.

Note that if a connected USB flash drive doesn’t have the correct file (**m208.bin**) in its root folder no harm will occur if power is applied to the Model 208. Upon power up the mic on/off button’s LED will flash on and off rapidly for a few seconds to indicate this condition and then normal operation using the unit’s existing application firmware will begin.

## Ultimo Firmware Update

As previously discussed in this guide, the Model 208 implements Dante connectivity using the 2-input/2-output Ultimo integrated circuit from Audinate. The Dante Controller software application can be used to determine the version of the firmware (embedded software) that resides in the Ultimo “chip.” The STcontroller software

application can also be used to identify the firmware version. (Use the Version selection under the Device tab.) The Dante firmware can be updated by way of the Model 208’s Ethernet connection. The latest Dante firmware file is available on the Studio Technologies website. The Dante Firmware Update Manager (FUM) application is used to install the firmware. This program is also available for download on the Studio Technologies website. It’s anticipated that a more automated method of updating Dante firmware will become available. If this comes to fruition then it might offer a much simplified method of keeping the firmware current.

## Restoring Factory Defaults

A command in the STcontroller software application allows the Model 208’s defaults to be reset to the factory values. From STcontroller select the Model 208 for which you want to restore its defaults. Select the **Device** tab and then the **Defaults** tab. Select the **Factory Defaults** feature. Then click on the **OK** box. The values shown on the screen should reflect the default values. They are:

Microphone P48 Phantom Power: Off  
Microphone Pre-Amplifier Gain: 35 dB  
Headphone Output Mode: Level/Level  
Sidetone Mode: Mic & Talkback Buttons  
Headphone Gain Range: Low  
Headphone Minimum Level: –40 dB  
Mic On/Off Button: Push to Mute  
Talkback Button: Push to Talk  
System Mode: On-Air

# Specifications

## **Power Source:**

**Power-over-Ethernet (PoE):** class 1 (very low power,  $\leq 3.84$  watts) per IEEE® 802.3af

## **Network Audio Technology:**

**Type:** Dante audio-over-Ethernet

**Bit Depth:** up to 24

**Sample Rate:** 44.1, 48, 88.2, and 96 kHz

**Number of Transmitter (Output) Channels:** 2

**Number of Receiver (Input) Channels:** 2

**Dante Audio Flows:** 4; 2 transmitter, 2 receiver

**AES67-2013 Support:** yes

**Dante Domain Manager (DDM) Support:** yes

## **Network Interface:**

**Type:** 100BASE-TX, twisted-pair Ethernet, Power-over-Ethernet (PoE) supported

**Data Rate:** 100 Mb/s (10 Mb/s and 1000 Mb/s "GigE" Ethernet not supported)

## **Microphone Input:**

**Compatibility:** dynamic or phantom-powered microphones

**Type:** balanced, capacitive coupled

**Impedance:** 2 k ohms, nominal

**Gain:** 35, 43, 52, 59 dB, selectable

**Frequency Response:** 25 Hz to 20 kHz,  $-3$  dB

**Distortion (THD+N):**  $<0.022\%$ , measured at 35 dB of gain

**Dynamic Range:** 96 dB, A-weighted

**Phantom Power:** P48 per IEC 61938 standard, on/off selectable with status LED

## **Compressor:**

**Application:** applies to Dante main and talkback transmitter (output) channels

**Threshold:** 1 dB above nominal level ( $-19$  dBFS)

**Slope:** 2:1

**Status LED:** compressor active

## **Microphone Output:**

**Type:** passive, via two 200 ohm resistors from microphone input (will pass phantom power in either direction)

**Muting:** solid-state relay contacts, 60 dB attenuation @ 1 kHz

## **Headphone Output:**

**Type:** dual-channel

**Compatibility:** intended for connection to stereo (dual-channel) or monaural (single-channel) headphones, headsets, or earpieces with nominal impedance of 50 ohms or greater

**Maximum Output Voltage:** 3.8 Vrms, 1 kHz, 150 ohm load

**Frequency Response:** 20 Hz to 20 kHz,  $-2$  dB

**Distortion (THD+N):**  $<0.002\%$

**Dynamic Range:**  $>100$  dB

## **Remote Control Inputs:**

**Functions:** controls mic on/off and talkback functions

**Type:** active low, 1 mA maximum, inputs pull up to 3.3 volts DC

## **Connectors:**

**Microphone Input:** 3-pin female XLR

**Microphone Output:** 3-pin male XLR

**Headphone Output:** 3-conductor  $\frac{1}{4}$ -inch jack

**Remote Control Inputs:** 3-conductor 3.5 mm jack

**Ethernet:** Neutrik etherCON RJ45

**USB:** type A receptacle (located inside Model 208's enclosure and used only for updating firmware)

**Configuration:** requires Studio Technologies STcontroller personal computer application, version 1.02.00 and later (STcontroller compatible with Windows® version 7 and later)

## **Dimensions (Overall):**

4.5 inches wide (11.4 cm)

1.6 inches high (4.0 cm)

4.8 inches deep (12.6 cm)

**Mounting:** intended for tabletop applications, top or bottom mounting with optional mounting bracket kit (Order Code: MBK-02)

**Weight:** 0.75 pounds (0.34 kg)

Specifications and information contained in this User Guide subject to change without notice.

## Appendix A: Views of Model 208 with Optional MBK-02 Mounting Brackets Installed



MBK-02 Mounting Brackets shown in Bottom-Mount (left) and Top-Mount (right) Positions

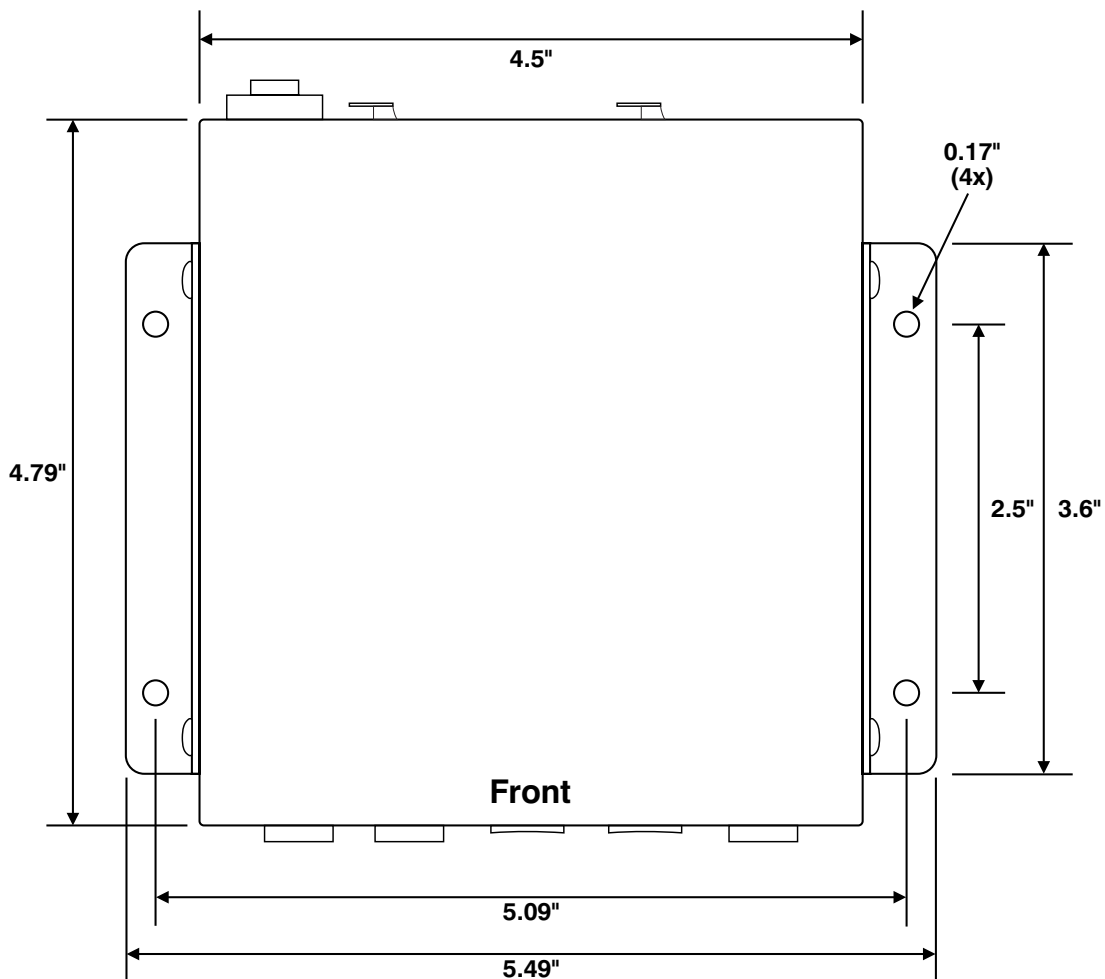

Overall Height with Brackets Installed = 1.63"

## Appendix B: Model 208 Block Diagram

The following block diagram shows a simplified version of the Model 208's microphone input and microphone output circuitry.

