



Model 380 On-Air Beltpack Featuring Dante® Technology

Key Features

- Dante audio-over-Ethernet technology
- Creates complete “stand-up” on-air position
- Configurable performance and operating modes
- Excellent audio quality
- Integrated sidetone function
- Power-over-Ethernet (PoE) powered

Introduction

The Model 380 On-Air Beltpack offers a unique combination of audio resources, providing main and talkback outputs, talent cue (IFB) input capabilities, and essential user controls in a compact, portable package. Optimized for broadcast sports and live entertainment events, news-gathering, and streaming broadcast applications, the unit allows incredibly simple deployment while maintaining “pro” audio quality and an intuitive user experience. The Model 380 integrates directly into both Dante audio-over-Ethernet and standard analog audio environments. With just a Power-over-Ethernet (PoE) connection, a dynamic microphone, and a pair of headphones or an earpiece, a complete broadcast “stand-up” on-air position can be created. And by using the Model 380’s microphone output a direct connection to an analog microphone-level input on an associated camera, camcorder, or audio console is also supported. Key features can be easily configured including microphone preamplifier gain, talkback button operation, headphone signal routing, and sidetone operation.

The Model 380’s audio quality is excellent, with low distortion, low noise, and high headroom. Careful circuit design and rugged components ensure long, reliable operation. A wide range of applications can be supported, including sports and entertainment TV and radio events, streaming

broadcasts, corporate and government AV installations, and post-production facilities. By providing the main (on-air) audio signal in two forms, Dante digital audio and analog microphone level, the Model 380 makes integration into a wide range of environments easy to accomplish. And with the talkback audio available as a Dante output channel, routing it to inputs on a variety of devices, such as matrix intercom systems, audio consoles, and monitor loudspeaker systems, is simple and flexible.

Applications

The Model 380 on its own can provide an “all-Dante” solution for one on-air talent location. Two Dante audio input channels supply the user with their talent cue (IFB) signals. Should the cue signal be “mix-minus” an integrated sidetone function can provide the user with a microphone confidence signal. Two Dante audio output channels, one designated as main (for on-air) and the other talkback, are routed via an associated local-area network (LAN) to inputs on Dante-compatible devices. A pushbutton switch, located on the Model 380’s top panel, provides a combination talkback and “cough” (user-controlled audio mute) function. When talkback is not active audio from the output of the unit’s microphone preamplifier is routed to the Dante main output channel; the Dante talkback output channel is muted. When the talkback function is active audio is muted on the Dante main output channel and activated on the Dante talkback output channel. The audio switching is performed in the digital domain and is virtually “click-free.”

Other applications may benefit from not utilizing the Model 380’s Dante main output channel. This typically won’t be an issue of inadequate audio quality but rather a need to match work-flow requirements. For example, for lip-sync



or transmission purposes it may be optimal to have the on-air audio transported as an embedded signal along with the associated camera video. Alternately, all on-air audio sources may need to connect to inputs on an audio console or console-related I/O unit. Supporting these scenarios is not a problem as the Model 380 supplies a microphone output connection that's specifically intended for this purpose. Simply connect the unit's microphone output connection to the desired analog input, such as the mic/line input on an ENG-style camera—that's it!

The circuitry associated with the Model 380's microphone output is very simple, essentially a passive path that routes a signal connected to the microphone input connector directly to the microphone output connector. A solid-state circuit, in series with the mic in-to-mic out path, allows muting of the signal on the microphone output connector whenever the talkback function is active. And it's important to note that using the microphone output connection doesn't impact the normal functioning of the Dante main and talkback output channels. This can be valuable, such as when utilizing the Dante main output channel as a back-up, secondary, or redundant on-air audio signal.

Setup and Operation

Set up and operation of the Model 380 is simple. An etherCON® RJ45 jack is used to interconnect with a standard twisted-pair Ethernet port associated with a PoE-enabled network switch. This connection provides both power and bidirectional digital audio. A handheld ("stick") microphone or broadcast stereo or monaural headset with a dynamic

microphone can be directly connected to the unit's 3-pin XLR input connector. Stereo headphones, the headphone connections from a stereo or monaural headset, or even a monaural earpiece are connected to the phones output jack.

Three "push-in/push-out" rotary level controls make it easy to set the level of the talent cue ("IFB") and sidetone levels being sent to the 2-channel headphone output. The Model 380's enclosure is made from an aluminum alloy which offers both light weight and ruggedness. A stainless steel "belt clip," located on the back of the unit, allows direct attachment to a user's clothing.

Dante Audio-over-Ethernet

Audio data is sent to and received from the Model 380 using the Dante audio-over-Ethernet media networking technology. As a Dante-compliant device, the Model 380's two output (Dante transmitter) and two input (Dante receiver) audio channels can be assigned to other devices (routed) using the Dante Controller software application. The Dante transmitter and receiver channels are limited to supporting four Dante flows, two in each direction. The digital audio's bit depth is up to 24 with a sampling rate of 44.1 or 48 kHz. Two bi-color LEDs provide an indication of the Dante connection status.

Audio Quality

The Model 380's performance is completely "pro" with capabilities not expected in something of such diminutive proportions. A low-noise, wide dynamic-range microphone preamplifier and associated voltage-controlled-amplifier

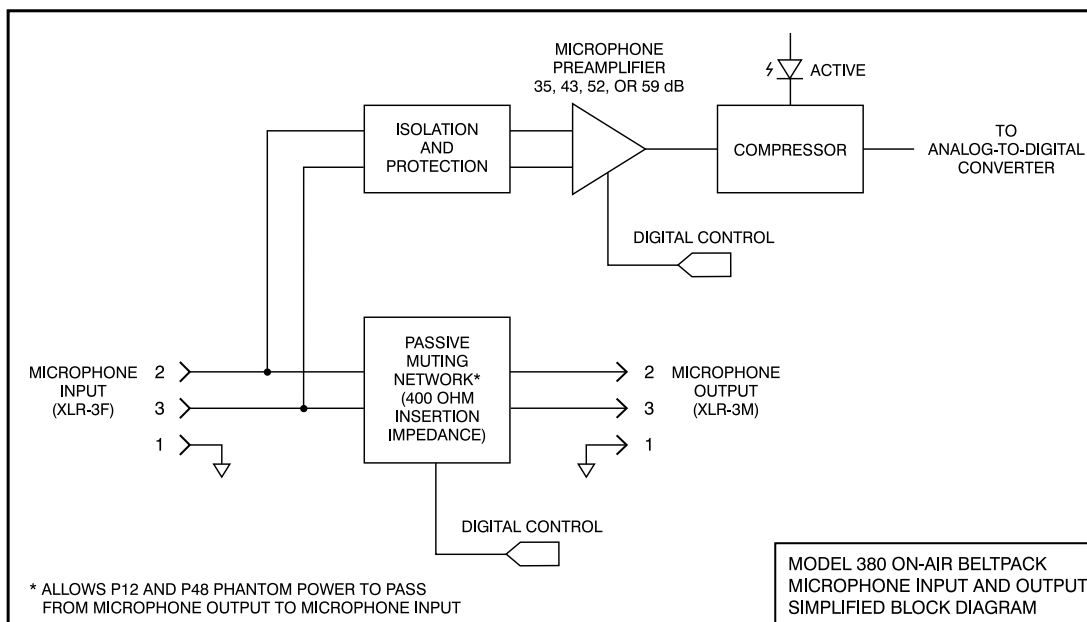



(VCA) dynamics controller (compressor) ensures that mic input audio quality is preserved while minimizing the chance of signal overload. The output of the microphone preamp and compressor is routed to an analog-to-digital conversion (ADC) section that supports sampling rates of 44.1 and 48 kHz with a bit depth of up to 24. The audio signal, now in the digital domain, routes through the processor and on to the Dante interface section where it is packetized and prepared for transport over Ethernet.

Audio input signals arrive via the Dante receiver channels and pass into the Model 380's processor. The sampling rate will be 44.1 or 48 kHz with a bit depth of up to 24. Channel routing, headphone level control, and sidetone creation are performed within the digital domain. This provides flexibility, allows precise control, and keeps the three level potentiometers (two for audio inputs and one for sidetone) from having to directly handle analog audio signals. The two audio channels destined for the phones outputs are sent to a high-performance digital-to-analog converter and then on to robust driver circuitry. High signal levels can be provided to a variety of headsets, headphones, and earpieces.

Configuration Flexibility

Several configuration choices are available, allowing the Model 380 to meet the needs of specific applications and user preferences. Six DIP switches, located under the belt clip, facilitate selection of key parameters including microphone preamplifier gain, headphone output mode, talkback button mode, and sidetone operation. Two of the

DIP switches are used to select the gain of the microphone preamplifier from among four choices. This allows the Model 380 to match the output sensitivity of a range of handheld and headset-associated microphones.

Using two DIP switches the headphone output mode can be configured from among four choices. The level/level mode is provided for broadcast applications where two channels of talent cueing ("IFB") need to be independently sent to the left and right headphone output channels. In on-air sports events it's typical for program audio with director interrupt to be sent to the left headphone output while program-only audio is sent to the right headphone output.

The level/balance mode is intended for applications where a stereo signal is being routed to the Model 380's Dante inputs. In this mode the user is provided with one potentiometer to control the overall level of both headphone output channels and a second potentiometer to control the left/right level balance.

The dual-channel monaural mode allows the two Dante input audio channels to be summed (mixed together) and sent to both the left and right headphone output channels.

Lastly, a unique single-channel monaural mode is provided for on-air talent cue applications where a single-channel earpiece or earbud is being used. The two Dante audio input channels are mixed and sent only to the left channel of the headphone output. No audio signal is present on the headphone output's right channel.

The pushbutton switch, located on the Model 380's top panel, can be configured to operate in either a momentary or latching mode. While the functional differences are somewhat subtle, the two modes allow distinct applications to be supported. In the momentary mode the button can provide a combination talkback function. This would be applicable for on-air sports applications where the microphone signal typically remains active. In the latching mode the button could be considered as serving as a microphone-on/off control. This would be useful in applications where talent requires local control of their microphone on and off status.

The integrated sidetone function can be enabled or disabled as required. This is important as different applications may, or may not, provide "mix-minus" talent cue signals. In the case where no mix-minus signal is present, providing a Model 380 user with sidetone is an important means of confirming their local microphone audio.

Ethernet Data and PoE

The Model 380 connects to an Ethernet data network using a standard 100 Mb/s twisted-pair Ethernet interface. The physical interconnection is made by way of a Neutrik® etherCON RJ45 connector. While compatible with standard RJ45 plugs, etherCON allows a ruggedized and locking interconnection for harsh or high-reliability environments. An LED displays the status of the network connection.

The Model 380's operating power is provided by way of the Ethernet interface using the 802.3af Power-over-Ethernet (PoE) standard. This allows fast and efficient interconnection with the associated data network. To support PoE power management, the Model 380's PoE interface reports to the power sourcing equipment (PSE) that it's a class 1 (very

low power) device. If a PoE-enabled Ethernet port can't be provided by the associated Ethernet switch a low-cost PoE midspan power injector can be utilized.

Future Capabilities and Firmware Updating

The Model 380 was designed so that its capabilities and performance can be enhanced in the future. A USB connector, located on the unit's main circuit board (underneath the unit's cover), allows the application firmware (embedded software) to be updated using a USB flash drive.

The Model 380 uses Audinate's Ultimo™ integrated circuit to implement the Dante interface. The firmware in this integrated circuit can be updated via the Ethernet connection, helping to ensure that its capabilities remain up to date.

Model 380 Specifications

Power Source:

Power-over-Ethernet (PoE): class 1 (very low power, ≤3.84 watts)

Network Audio Technology:

Type: Dante audio-over-Ethernet

AES67-2013 Support: yes

Dante Domain Manager (DDM) Support: yes

Bit Depth: up to 24

Sample Rate: 44.1 and 48 kHz

Number of Transmitter (Output) Channels: 2

Number of Receiver (Input) Channels: 2

Dante Audio Flows: 4; 2 transmitter, 2 receiver

Network Interface:

Type: twisted-pair Ethernet, Power-over-Ethernet (PoE) supported

Data Rate: 100 Mb/s (10 Mb/s Ethernet not supported)

Microphone Input:

Compatibility: dynamic microphones; P12 or P48 phantom powered mics are compatible when powered by an external source

Type: balanced, capacitive coupled (protected from presence of P12 or P48)

Impedance: 2 k ohms, nominal

Gain: 35, 43, 52, 59 dB, selectable

Frequency Response: 30 Hz to 20 kHz, -3 dB

Distortion (THD+N): <0.025%

Dynamic Range: 93 dB, A-weighted

Compressor:

Application: applies to Dante main and talkback output channels

Threshold: 1 dB above nominal level (-19 dBFS)

Slope: 2:1

Status LED: compressor active

Microphone Output:

Type: passive, via 200 ohm resistors from microphone input, will pass phantom power to microphone input

Muting: solid-state relay contacts, 60 dB attenuation @ 1 kHz

Headphone Output:

Type: dual-channel

Compatibility: intended for connection to mono or stereo headsets or earpieces with nominal impedance of 50 ohms or greater

Maximum Output Voltage: 3.8 Vrms, 1 kHz, 150 ohm load

Frequency Response: 20 Hz to 20 kHz, -2 dB

Distortion (THD+N): <0.002%

Dynamic Range: >100 dB

Connectors:

Microphone Input: 3-pin female XLR

Microphone Output: 3-pin male XLR

Headphone Output: ¼-inch 3-conductor jack

Ethernet: Neutrik etherCON RJ45

USB: type A receptacle (located inside Model 380's enclosure and used only for firmware updates)

Environmental:

Operating Temperature: 0 to 50 degrees C (32 to 122 degrees F)

Storage Temperature: -40 to 70 degrees C (-40 to 158 degrees F)

Humidity: 0 to 95%, non-condensing

Altitude: not characterized

Dimensions (Overall):

3.8 inches wide (9.6 cm)

1.6 inches high (4.0 cm)

4.8 inches deep (12.6 cm)

Deployment: intended for portable applications; contains integral belt clip

Weight: 0.7 pounds (0.3 kg)

Specifications subject to change without notice.