



Model 233

Announcer's Console



Configuration Guide

This Configuration Guide is applicable
for the following serial numbers:
M233-01151 and later

Model 233 Configuration Settings

For full documentation go to www.studio-tech.com

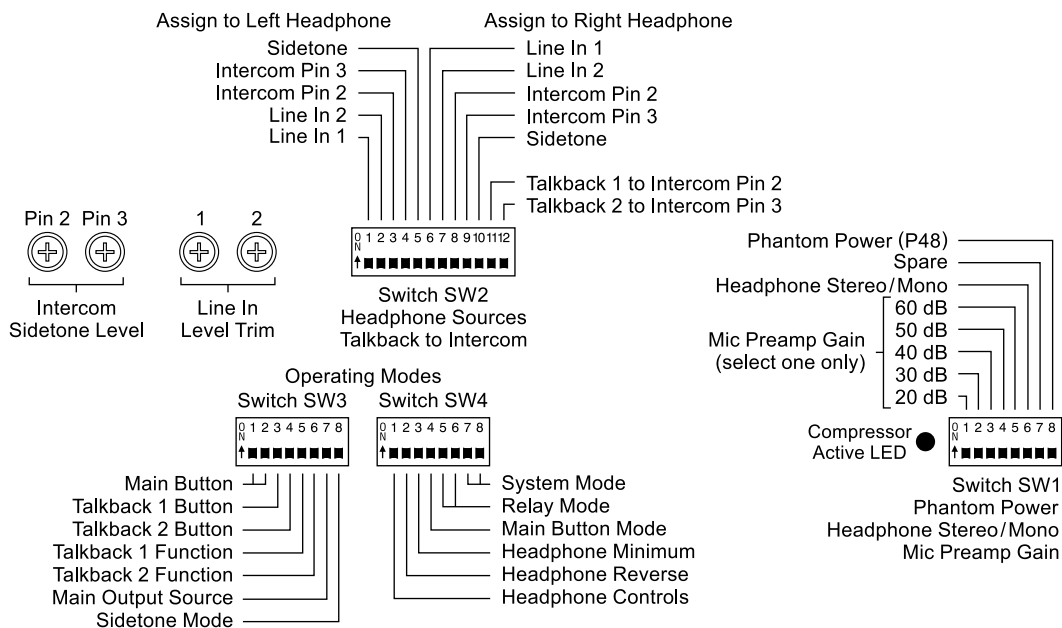

Main Button

- ▼▼ Push to Mute
- ▲▼ Push to Talk
- ▼▲ Latching
- ▲▲ Hybrid

Talkback 1/2 Button

- ▼ Push to Talk
- ▲ Hybrid

Talkback 1/2 Function

- ▼ Disabled (Relay Only)
- ▲ Enabled

Main Output Source

- ▼ Mic Preamplifier
- ▲ Compressor

Sidetone Mode

- ▼ Main Button
- ▲ Main & Talkback Buttons

Headphone Controls

- ▼ Level/Level
- ▲ Level/Balance

Headphone Reverse

- ▼ Normal
- ▲ Reverse

Headphone Minimum

- ▼ -40 dB
- ▲ Full Mute

Main Button Mode

- ▼ Normal
- ▲ Talkback Forces Latch Off

Relay Mode

- ▼▼ Disabled
- ▲▼ Follows Main Out
- ▼▲ Follows Talkback 1
- ▲▲ Follows Talkback 2

System Mode

- ▼▼ On-Air
- ▲▼ Stadium Announce
- ▼▲ Production
- ▲▲ Reserved

Phantom Power (P48)

- ▼ Off
- ▲ On

Headphone Stereo/Mono

- ▼ Stereo
- ▲ Mono

Talkback 1 to Intercom Pin 2

- ▼ Off
- ▲ On

Talkback 2 to Intercom Pin 3

- ▼ Off
- ▲ On

Intercom Pin 2 is RTS™ TW Channel 1.
Intercom Pin 3 is RTS™ TW Channel 2
or Clear-Com® Channel 1.

**STUDIO
TECHNOLOGIES**

www.studio-tech.com

31267 Rev A

Model 233 Bottom Panel

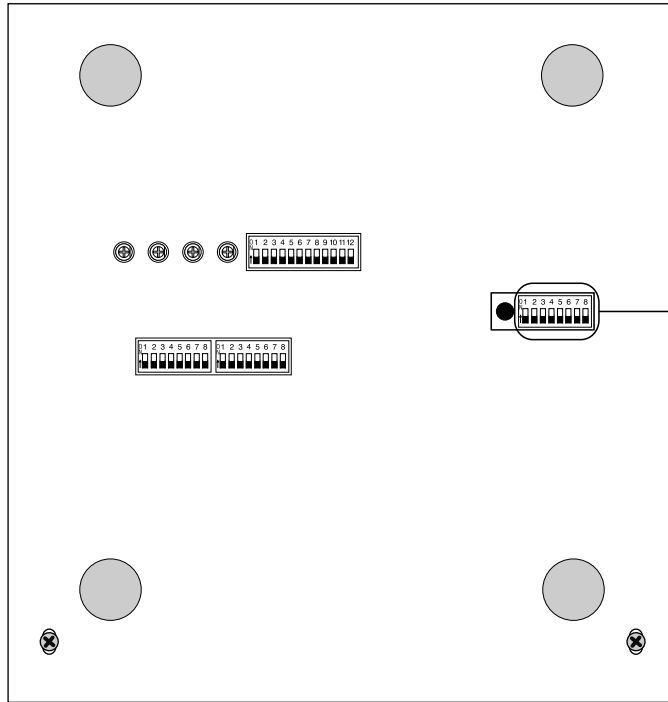

Switch 1 Settings
Detailed Below

SW1-1 through SW1-5 – Mic Preamp Gain

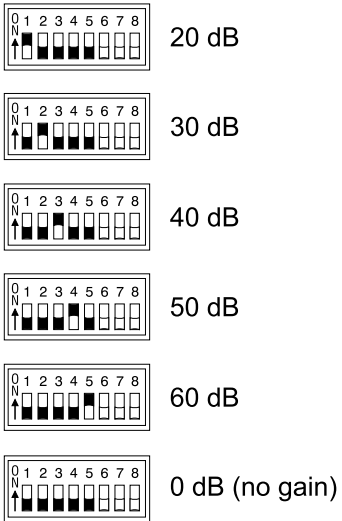

SW1-6 – Headphone Output Mode

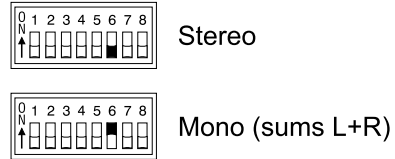

SW1-8 – Phantom Power (P48)

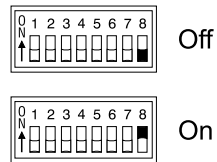

Model 233 Bottom Panel

**Switch 2 Settings
Detailed Below**

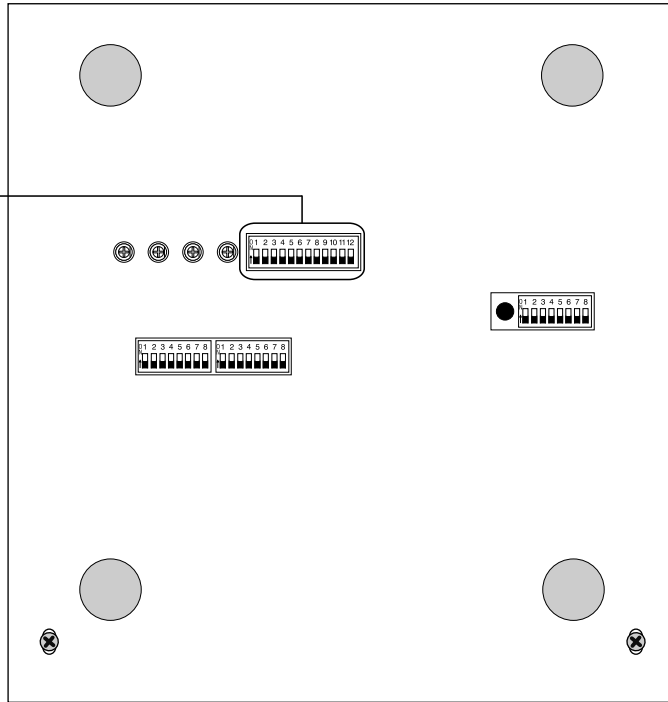

SW2-1 through SW2-5 – Left Channel Headphone Source Selection

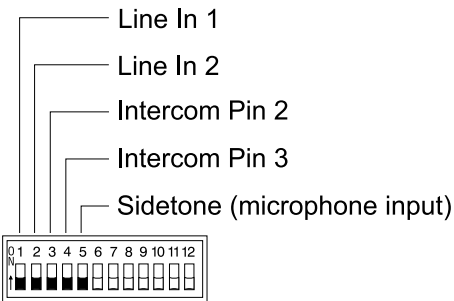

On to enable source; multiple sources will sum

Intercom Pin 2 is RTS™ TW Channel 1.
Intercom Pin 3 is RTS™ TW Channel 2,
or Clear-Com® Channel 1.

SW2-6 through SW2-10 – Right Channel Headphone Source Selection

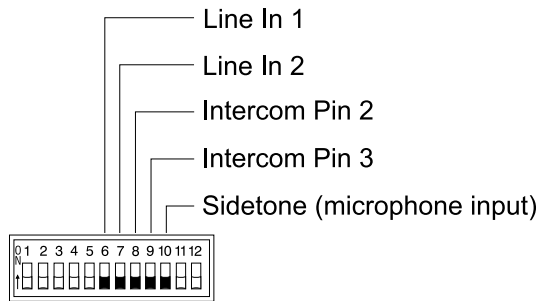

On to enable source; multiple sources will sum

Intercom Pin 2 is RTS™ TW Channel 1.
Intercom Pin 3 is RTS™ TW Channel 2,
or Clear-Com® Channel 1.

SW2-11 – Talkback 1 to Intercom Pin 2

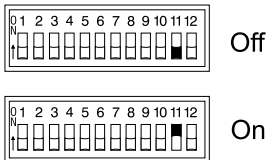

SW2-12 – Talkback 2 to Intercom Pin 3

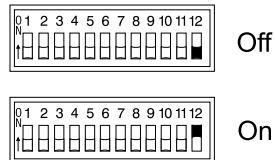

Model 233 Bottom Panel

Switch 3 Settings
Detailed Below

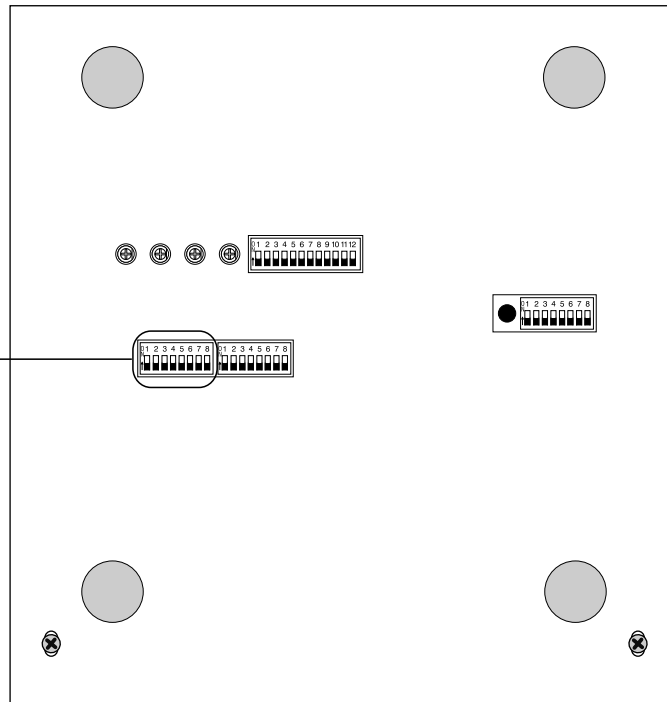

SW3-1 and SW3-2 – Main Button Mode

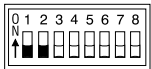

Push to mute (“cough”)

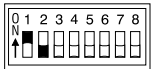

Push to talk

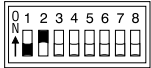

Alternate action (“latching”)

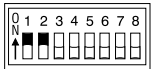

Hybrid (press and hold to enable, tap to latch)

SW3-5 – Talkback 1 Function Mode

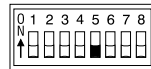

Disabled (unless assigned to relay)

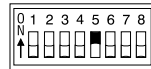

Enabled

SW3-6 – Talkback 2 Function Mode

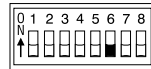

Disabled (unless assigned to relay)

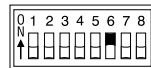

Enabled

SW3-3 – Talkback 1 Button Mode

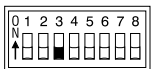

Push to talk

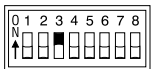

Hybrid (press and hold to enable, tap to latch)

SW3-7 – Main Output Source

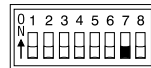

Mic preamplifier

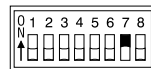

Compressor

SW3-4 – Talkback 2 Button Mode

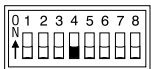

Push to talk

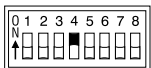

Hybrid (press and hold to enable, tap to latch)

SW3-8 – Sidetone Mode

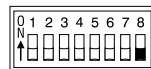

Main button controls sidetone

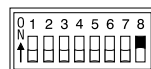

Main and talkback buttons control sidetone

Model 233 Bottom Panel

Switch 4 Settings
Detailed Below

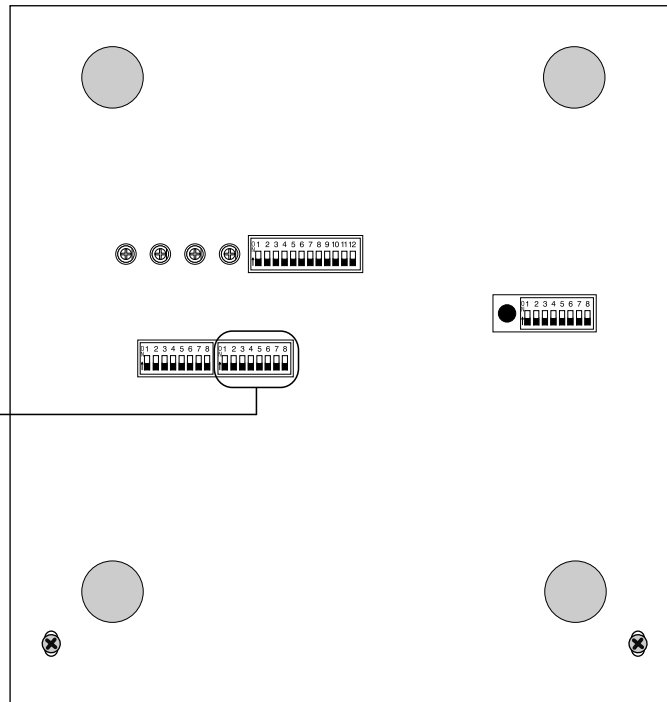

SW4-1 – Headphone Control Mode

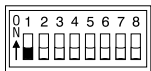

Dual channel (“level/level”)

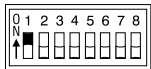

Stereo (“level/balance”)

SW4-2 – Headphone Control Operation

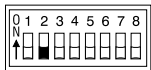

Normal

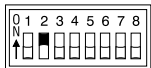

Reverse left/right

SW4-3 – Headphone Output Minimum Level

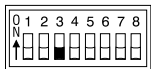

-40 dB

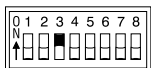

Full mute

SW4-4 – Main Button Mode

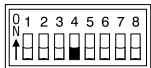

Normal (talkback does not “unlatch” main output)

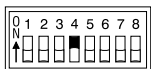

Force off (talkback forces main button to “unlatch”)

SW4-5 and SW4-6 – Relay Control Mode



Relay disabled

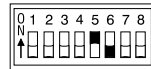

Follows main output status

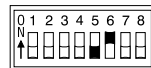

Follows talkback 1 button status

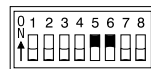

Follows talkback 2 button status

SW4-7 and SW4-8 – System Mode

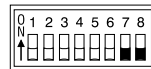

On-air (talkback output status impacts main output status)

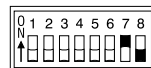

Stadium Announce (main output status impacts headphone output; talkback output status impacts main output status)

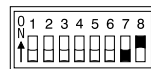

Production (talkback output status does not impact main output status)

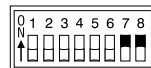

Reserved