

Model 44D

Audio Interface

Dante® to and from Analog Audio

User Guide

Issue 6, February 2023

This User Guide is applicable for serial numbers M44D-01151 and later with application firmware 2.2 and later and Dante firmware 4.6.0 (UltimoX2 4.2.2.3) and later

Also applicable to units with serial numbers M44D-00151 to 00250; see Appendix A for details

Copyright © 2023 by Studio Technologies, Inc., all rights reserved
studio-tech.com

This page intentionally left blank.

Table of Contents

Revision History	4
Introduction	5
Getting Started	10
Configuration	14
Operation	18
Technical Notes.....	22
Specifications.....	26
Appendix A: Original vs Updated Model 44D	28
Appendix B: Interfacing with RTS® Matrix Intercom Systems	31
Appendix C: Interfacing with Riedel® Artist™ Matrix Intercom Systems	32
Appendix D: Interfacing with Clear-Com® Matrix Intercom Systems	33

Revision History

Issue 6, February 2023:

- Clarifies tone generator frequencies versus sample rate.

Issue 5, April 2021:

- Added Appendices B, C, and D. Details how to interface the Model 44D with matrix intercom systems.

Issue 4, June 2020:

- Documents deletion of pull-up/pull-down capability.

Issue 3, August 2018:

- Documents change of tone frequencies from 1 kHz and 18 kHz to 18 kHz and 20 kHz.

Issue 2, November 2017:

- Documents addition of operating mode configuration (audio interface and tone generator).

Issue 1, September 2016:

- Initial release.

Introduction

The Model 44D Audio Interface provides a simple yet high-performance means of interfacing two channels of analog line-level audio to and from applications that utilize Dante® audio-over-Ethernet media networking technology. Two Model 44D units can also provide one-to-one signal paths, two in each direction, over a standard local area network (LAN). In addition, the unit supports transport of status signals or contact closures between Model 44D units and other compatible products. There are two general-purpose inputs (GPI) and two general-purpose output (GPO) on each Model 44D.

A special operating mode allows the Model 44D to serve as a tone generator rather than an audio interface. When configured for the tone generator mode 18 kHz and 20 kHz sine-wave audio signals are available in both the analog and digital domains. These frequency values are applicable when the Dante sample rate is configured for 48 kHz. When the

Dante sample rate is 44.1 kHz, the tone generator output frequencies will be 16.5375 kHz and 18.375 kHz, respectively.

The Model 44D is a fully professional product that offers the audio quality, features, and reliability required by 24-hour, on-air, and commercial applications. The two line-level audio inputs use standard 3-pin female XLR connectors for easy interfacing with balanced and unbalanced sources. The input audio signals are converted to 24-bit digital and then transported via the Dante interface. Two digital audio signals arrive into the Model 44D via the Dante interface and are then converted to analog. Two 3-pin male XLR connectors on the Model 44D's back panel provide balanced line-level outputs.

The Model 44D is designed as a bridge, using Dante to link analog or other Dante interfaces found on devices such as matrix intercom systems, broadcast routers, and audio consoles. An Ethernet connection is all that's required to make the Model 44D part of a sophisticated, networked audio system. Dante audio-over-Ethernet has

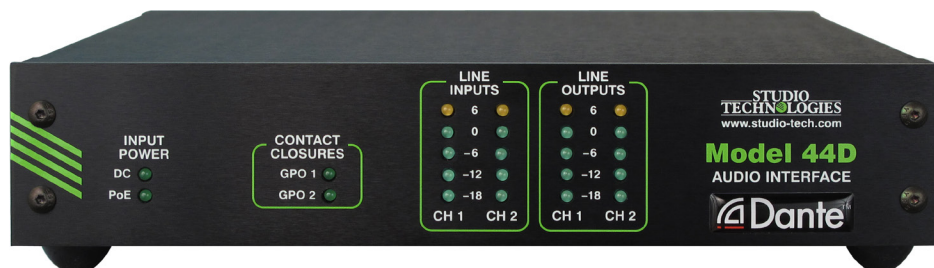

Figure 1. Model 44D standard “throw-down” front view



Figure 2. Model 44D back view

found wide acceptance as an audio “backbone” due to its ease of use, high performance, strong interoperability, and wide adoption by a large number of equipment manufacturers. The Model 44D is a general-purpose “tool” that helps to expand Dante’s capabilities to facilities and equipment that primarily supports signals in the analog domain.

Careful attention to circuit design and component selection ensures that excellent audio quality is maintained. Extensive filtering helps prevent damage or less-than-optimal performance should DC voltage, ESD (“static”), or strong RF signals be present on the associated analog signals.

Configuration switches allow several Model 44D operating parameters to be selected. The nominal audio levels of the line input and line output functions can be independently selected. In this way compatibility with SMPTE® and EBU nominal signal levels is supported. Audio level meters provide confirmation of system performance during setup and operation. Two general purpose input and two general purpose output functions allow support for installer-selected applications, including party-line intercom call-light functions. Two LEDs provide a direct indication of the status of the GPO functions.

The Model 44D can be powered by Power-over-Ethernet (PoE) or an external source of 12 volts DC. Standard connectors are used for the line inputs and outputs, Ethernet, GPI/GPO, and DC power interconnections. The Model 44D’s enclosure has a “1/2-rack” 1U form factor and weighs less than two pounds, making it well suited for use in portable applications. Alternately, using one of the optional rack-mount front panels, one or two Model 44D units can be

mounted in a single space (1U) of a standard 19-inch rack enclosure.

Dante Audio-over-Ethernet

Audio data is sent to the Model 44D using the Dante audio-over-Ethernet media networking technology. Audio signals with a sample rate of 44.1 or 48 kHz and a bit depth of up to 24 are supported. The two line input channels are converted to digital and then routed to transmitter (output) channels on the Dante interface. Two transmitter (output) channels from an associated Dante-enabled source device can be assigned to the Model 44D’s receiver (input) channels using the Dante Controller application. These are then converted into analog outputs.

Applications

The most basic application for Model 44D is for transporting analog audio signals to and from one location to another using the data transport resources of a local area network — there’s really no simpler means to getting high-quality audio from “point A to point B” and back. With standard connectors and PoE power, setup can be completed in just a few minutes. This makes Model 44D units effective in both fixed and portable applications.

The Model 44D can also find use when an application already supports Dante. For example, ports on a matrix intercom system that directly supports Dante, such as the RTS® ADAM® with OMNEO®, can be routed to a Model 44D’s Dante output (transmitter) and input (receiver) channels. The Model 44D will then provide two analog input and two analog output interfaces for use in a variety of applications. These can include interfacing with audio inputs

and outputs associated with audio consoles, providing talent cueing (IFB) feeds, and interfacing with the audio outputs of aerial camera systems.

The Model 44D's tone generator mode enables the unit to create 18 kHz and 20 kHz analog and digital sine-wave audio signals. The 18 kHz tone is provided as a resource when supporting remote-production (REMI) applications that use the Studio Technologies' Model 5422 Dante Intercom Audio Engine. The tone can be used by a matrix intercom system to facilitate creation of voice-with-tone interruptible foldback (IFB) signals. When routed to the Model 5422's interrupt inputs these specialized IFB signals will allow excellent talent cueing performance to occur.

The 20 kHz tone is provided for use in applications where generation of a party-line call signal is desired. For example, the 20 kHz tone can be connected to a matrix intercom system which would be configured such that a button press will cause 20 kHz to be sent out an intercom channel. This can serve as a "trigger" signal for visual or audible alerting devices, such as the Studio Technologies' Model 391 Dante Alerting Unit.

Note that the frequencies described (18 kHz and 20 kHz) are effective when the Dante sample rate is configured for 48 kHz. When the Dante sample rate is 44.1 kHz, the tone generator output frequencies will be 16.5375 kHz and 18.375 kHz, respectively.

Line Inputs

The Model 44D provides two analog line-level input channels. A configuration choice allows the nominal level of the input signals to be +4 or 0 dBu. When

configured for +4 dBu the unit will be compatible with SMPTE applications where the nominal digital signal level is -20 dBFS. In the 0 dBu configuration the line inputs are optimized for EBU applications where the nominal digital signal level is -18 dBFS.

The electronically balanced (differential) input circuits are capacitor-coupled and ESD (static) protected for reliable operation in a variety of applications. They are also protected from damage should a moderate DC voltage be accidentally connected. Sources can include analog I/O cards on matrix intercom systems, audio consoles, wireless microphone receivers, and broadcast routers.

Line Outputs

The Model 44D provides two analog line-level output channels. As with the line inputs, a configuration choice allows the nominal level of the output signals to be +4 or 0 dBu. This allows compatibility in applications where SMPTE (+4 dBu = -20 dBFS) or EBU (0 dBu = -18 dBFS) standards may apply. The outputs are electronically balanced, capacitor-coupled and ESD (static) protected. The outputs are compatible with virtually all balanced and unbalanced inputs with an impedance of 2 k ohms or greater.

General Purpose Inputs and Outputs

The Model 44D allows the sending and receiving of status signals using high-frequency audio tones that are included within the Dante audio channels. When two Model 44D units are interconnected using an Ethernet network and Dante, two status signals will be transport-

ed in each direction. Each general purpose input (GPI) is compatible with contact closures provided by equipment such as matrix intercom systems or routers. A closure on a GPI on one Model 44D unit will result in the closing (shorting) of a solid-state relay contact on the other Model 44D. To assist in implementing specialized GPI and GPO applications a source of low-current DC power is also provided.

The GPI and GPO functions can be especially useful in party-line intercom applications where call-light signals are utilized. Contact closures on matrix intercom systems can be “repeated” by Model 44D units that are located anywhere within the associated local area network (LAN). The Model 44D is also directly compatible with the call-light signal support provided by the Studio Technologies’ Model 45DC and Model 45DR Intercom Interface units. With a Model 44D appropriately interconnected with a matrix intercom system full call-light support can be provided to and from RTS and Clear-Com® party-line intercom circuits.

Pro Audio Quality

The Model 44D’s audio circuitry was designed in the spirit of professional audio equipment rather than that found in typical broadcast or commercial audio gear. High-performance components are used throughout, providing low-distortion, low-noise, and high headroom. Care was taken so that signal integrity is maintained in both the analog and digital domains.

Audio Meters and Status LEDs

The Model 44D provides four 5-segment LED meters. The meters, located on the front panel, display the level of the audio

signals associated with the two line inputs and two line outputs. At the time of installation and setup the meters are invaluable in helping to confirm correct operation. During normal operation the meters offer direct confirmation of the unit’s audio signal levels, helping to ensure that optimal audio quality is maintained. Additional LED indicators are provided on the front panel, offering status indications of the incoming power and general purpose output (GPO) functions.

Tone Generator Mode

For special applications the Model 44D can be configured to serve as a tone generator. Instead of functioning as an audio interface device, the Model 44D will generate two sine-wave audio signals, one 18 kHz and the other 20 kHz. These signals are available both as line-level analog and Dante digital audio (transmitter) outputs. The 18 kHz tone is intended for use with matrix intercom systems that are used with the Studio Technologies’ Model 5422 Dante Intercom Audio Engine. This tone will be connected to a matrix intercom system using either analog or Dante inputs. The matrix intercom system will be configured such that it will combine voice audio with the 18 kHz tone to create specialized IFB signals. These voice-with-tone signals will be routed, by way of an audio transport system, to Model 5422 interrupt inputs associated with tone operated (TOX) IFB channels. The Model 5422 will detect the 18 kHz tone and “trigger” the associated IFB function. In this way high-performance IFB functions can be implemented for REMI (remote-production) applications.

The 20 kHz tone is provided for use in applications where generation of in-band signals that are compatible with the call

function on RTS TW-series party-line (PL) intercom channels is desired. One example would be for the 20 kHz tone to be connected to an analog or Dante receiver (input) channel on a matrix intercom system. The intercom system would be configured such that a button press on an intercom “key” panel would cause 20 kHz to be sent out an intercom channel. This would then serve as a call “trigger” for devices such as a Studio Technologies’ Model 391 Dante Alerting Unit. Another interesting example would be for the 20 kHz tone to be used to serve as an activation signal for contact closures. Using Dante subscriptions (routes), the intercom channel from the matrix interface would be connected to additional Model 44D units. When those units receive the 20 kHz tone signal they would enable their associated GPO contact closure.

Both the 18 kHz and 20 kHz tones are precise in terms of frequency and level accuracy, as well as being very low in harmonic distortion.

Ethernet Data, PoE, and DC Power Source

The Model 44D connects to a data network using a standard 100 Mb/s twisted-pair Ethernet interface. The physical interconnection is made by way of a Neutrik® etherCON RJ45 connector. While compatible with standard RJ45 plugs, etherCON allows a ruggedized and locking interconnection for harsh or high-reliability environments. The Model 44D’s operating power can be provided by way of the Ethernet interface using the Power-over-Ethernet (PoE) standard. This allows fast and efficient interconnection with the associated data network. To support PoE power management, the Model 44D’s PoE interface

reports to the power sourcing equipment (PSE) that it is a class 1 (very low power) device. The unit can also be powered using an external source of 12 volts DC. Four LEDs on the back panel display the status of the network connection, Dante interface, and PoE power source.

Simple Installation

The Model 44D uses standard connectors to allow fast and convenient interconnections. An Ethernet signal is connected using a Neutrik etherCON RJ45. If Power-over-Ethernet (PoE) is available operation will commence immediately. An external 12 volt DC power source can also be connected by way of a 4-pin XLR connector. Line input and line output connections are made using 3-pin XLR connectors. A 9-pin female D-subminiature (DE-9F) connector provides access to the two GPI, two GPO, and auxiliary DC output functions. The Model 44D is housed in a rugged yet lightweight aluminum enclosure that is designed to be “field tough.” It can be used as a standalone portable unit, supporting what’s known in the broadcast world as “throw-down” applications. Rack-mount options are also available allowing one or two units to be mounted in one space (1U) of a standard 19-inch rack enclosure.

Future Capabilities and Firmware Updating

The Model 44D was designed so that its capabilities can be enhanced in the future. A USB connector, located on the unit’s main circuit board (underneath the unit’s cover), allows the application firmware (embedded software) to be updated using a USB flash drive.

To implement the Dante interface the Model 44D uses Audinate's Ultimo™ integrated circuit. The firmware in this integrated circuit can be updated via the unit's Ethernet connection, helping to ensure that its capabilities remain up to date.

Getting Started

In this section signal interconnections will be made using the variety of connectors located on the Model 44D's back panel. Connections to the two line inputs and two line outputs will be made using 3-pin male and female XLR connectors. An Ethernet data connection will be made using either a standard RJ45 patch cable or an etherCON protected RJ45 plug. A 4-pin XLR connector allows the connection of an external source of 12 volts DC. Interfacing with the GPI, GPO, and auxiliary DC output functions can be made using a 9-pin female D-subminiature (DE-9F) connector.

System Components

Included in the shipping carton are the Model 44D Interface and instructions on how to obtain an electronic copy of this guide. If a rack-mount front panel is going to be used as part of the installation it will typically be shipped in a separate carton. If the installation or specific application requires an external source of 12 volts DC it needs to be provided separately. A compatible power supply, the Studio Technologies' PS-DC-02, is available as an option.

Locating the Model 44D

The location of the Model 44D will primarily depend on being within the 100-meter (325-foot) twisted pair Ethernet cable limitation. But that can be overcome by using a

fiber-optic interconnect between the Model 44D-related Ethernet switch and the other Ethernet switches in the local-area-network (LAN). The analog line input and line output connections, typically being wired as a differential (balanced) pair with shield, can support lengthy cable runs with negligible impact on audio quality.

Protecting the Enclosure

The Model 44D is shipped as a self-contained unit suitable for portable use or placement in a semi-permanent location. Installed on the bottom of the chassis are screw-on "bump on" protectors (also known as "rubber feet"). These are useful if the unit is going to be placed on surfaces where scratching of either the Model 44D or the surface material could take place. The "feet" can be removed, without the use of a tool, when rack- or custom-mounting the unit.

Rack Mounting the Model 44D

For permanent or mobile applications it might be desirable to mount one or two Model 44D units into one space (1U) of a 19-inch rack enclosure. A range of rack-mount front panels, each purchased separately, are available from Studio Technologies. The following provides details on how to install Model 44D units to these panels.

To attach a Model 44D unit to the single-unit rack-mount panel, begin the process by using a 5/64-inch hex wrench to remove the four 6-32 thread button-head cap screws that hold the standard front panel to the chassis. Note that the screws might be quite tightly affixed. Ensure that a good-quality hex wrench is used and press and hold it firmly into each screw head while turning counterclockwise. Unless this

recommendation is followed the hex wrench could “cam out” and the head could be damaged (“stripped”).

Using the screws that were just removed, attach the rack-adaptor front panel to the Model 44D’s chassis. To prevent damage care is required when aligning the front panel with the LEDs that protrude slightly through both the Model 44D’s chassis and front panel. Tighten the four screws only after a careful inspection ensures that all of the LEDs protrude through the front panel without interference. To allow vertical clearance in the associated rack, remove the four “bump on” protectors from the bottom of the chassis. They are removed by using the fingers to rotate them counterclockwise; no tool is required. It’s probably a good idea to carefully protect and store the standard front panel, along with the “bump on” protectors, for possible later use.

Mounting a Model 44D to a dual-unit rack-mount panel follows the same procedure but will apply to two units. Store both of the removed standard front panels and the eight “bump on” protectors for possible later use. Note that on the rack-panel’s graphics the Model 44D unit that’s on the left is designated as A while the unit on the right is designated as B. This is provided so that each can be easily identified during installation, troubleshooting, and operation.

Once the desired one or two Model 44D units have been installed in a rack-mount front panel, the assembly can be mounted into the designated equipment rack. One space (“1U” or 1.75 vertical inches) in a standard 19-inch equipment rack is required. Secure the front panel into the equipment rack using two mounting screws per side.

Ethernet Connection

An Ethernet connection that supports 100BASE-TX (100 Mb/s over twisted-pair) is required for the Model 44D’s Dante audio-over-Ethernet connectivity. A 10BASE-T connection is not sufficient for Model 44D operation. A 1000BASE-T (“GigE”) connection is not supported unless it can automatically “fall back” to 100BASE-TX operation. An Ethernet connection that supports Power-over-Ethernet (PoE) is preferred as it will provide both data and operating power for the Model 44D. To support power management functionality on an associated PoE switch (PSE) the Model 44D will enumerate itself as a PoE class 1 (very low power) device. If PoE is not available an external 12 volt DC power source can be connected. This will be discussed in a later sub-section of the guide.

The 100BASE-TX Ethernet connection is made by way of a Neutrik etherCON protected RJ45 connector that is located on the back panel of the Model 44D. This allows connection by way of a cable-mounted etherCON plug or a standard RJ45 plug. The Model 44D’s Ethernet interface supports auto MDI/MDI-X and, as such, using a crossover or “reversing” cable will not be required.

External 12 Volt DC Input

An external source of 12 volts DC can be connected to the Model 44D by way of a 4-pin male XLR connector which is located on the back panel. While the requirement for the external source is nominally 12 volts, correct operation will take place with any source that has a range of 10 to 18 volts DC. The Model 44D requires 300 milliamperes maximum at 12 volts DC for

correct operation. The DC source should be terminated to a 4-pin female XLR connector with pin 1 negative (–) and pin 4 positive (+). Purchased as an option, the PS-DC-02 power supply is available from Studio Technologies. Its AC mains input allows connection to a 100-240 volts, 50/60 Hz source and its 12 volt DC, 1.5 amperes maximum output is terminated on a 4-pin female connector.

As previously discussed, an Ethernet connection that provides Power-over-Ethernet (PoE) can serve as the Model 44D's power source. Alternately, an external 12 volt DC source can be connected. For redundancy, both PoE and an external 12 volt DC source can be connected at the same time. If both PoE and an external 12 volt DC source are connected, power will be drawn only from the PoE supply. If the PoE source becomes inoperative the 12 volt DC source will provide the Model 44D's power with no interruption in operation. (Of course, normal operation will cease if both PoE and data transport fails on the Ethernet connection.)

Line Inputs

The Model 44D provides two line inputs that are intended for connection to line-level analog audio signal sources associated with professional audio and video equipment. It's expected that the nominal level of the analog sources will either be +4 dBu for SMPTE applications or 0 dBu for EBU applications. (Refer to the Configuration section for details.) Commonly-used sources could include analog I/O ports on broadcast matrix intercom systems, audio consoles, video storage and playback systems, wireless microphone receivers, and audio testing equipment. The circuitry associated with the line

inputs is analog, electronically balanced, capacitor coupled, with an impedance of 20 k ohms.

Two 3-pin female XLR connectors, located on the Model 44D's back panel, are used for interfacing with the source signals. Prepare 3-pin male XLR mating connectors such that pin 2 is signal high (+), pin 3 is signal low (–), and pin 1 is common/shield. It's also highly possible that an unbalanced source will interface correctly. With an unbalanced source begin by connecting signal high (+) to pin 2 and signal low/shield (–) to both pins 1 and 3. If this results in hum or noise, next try connecting signal high (+) to pin 2 and signal low/shield (–) only to pin 3; leave pin 1 unconnected ("floating").

If the Model 44D has been configured to operate in the tone generator mode the two analog line inputs will not be active. As such, no connections should be made to either line input channel 1 or line input channel 2.

Line Outputs

The Model 44D provides two line outputs. These analog outputs are designed for general-purpose use which could include connecting to analog inputs on devices including matrix intercom systems, transmitters associated with wireless in-ear monitors, audio consoles, or amplified speakers. The circuitry associated with the line outputs is analog, capacitor-coupled, and has a source impedance of 200 ohms. It will perform optimally when driving loads of 2 k (2000) ohms or greater. The nominal level of the line outputs is configurable to be either +4 dBu or 0 dBu, corresponding to SMPTE or EBU applications. (Refer to the Configuration section for details.)

Two 3-pin male XLR connectors, located on the Model 44D's back panel, are provided for interfacing the line outputs with associated equipment. Prepare 3-pin female XLR mating connectors such that pin 3 is signal high (+), pin 2 is signal low (-), and pin 1 is common/shield. To connect to an unbalanced load use pin 2 as signal high (+) and pin 1 as low/shield; do not connect anything to pin 3. Do not short pins 3 to pin 1 on the Model 44D's line output connectors as it will stress the output circuitry.

Connections made to the line outputs will be the same whether the Model 44D has been selected to operate in the audio interface mode or in the tone generator mode. In the latter mode a continuous 18 kHz sine-wave tone will be present on line output channel 1 and a continuous 20 kHz sine-wave tone will be present on line output channel 2. The nominal level of both signals will be +4 dBu.

Note that the frequencies described (18 kHz and 20 kHz) are effective when the Dante sample rate is configured for 48 kHz. When the Dante sample rate is 44.1 kHz, the tone generator output frequencies will be 16.5375 kHz and 18.375 kHz, respectively.

General Purpose Inputs (GPI)

The Model 44D provides two general-purpose input functions that are referred to as GPI 1 and GPI 2. These functions allow transport of the status of relay contacts or open-collector logic signals. The Model 44D's GPI inputs use logic circuitry, "pulled up" to 3.3 volts DC by way of resistors, which are active whenever they are brought to their logic low state. While the GPI input circuitry is protected from over-current and static discharge (ESD), care should be

taken to minimize the chance that "nasty" signals can reach them.

The GPI inputs are active only when held in their low state; they can't be configured to change state ("latch") in response to a logic pulse or momentary closure. Pins on a 9-pin female D-subminiature connector (DE-9F) are used for interfacing with the GPI inputs and system common connections. This connector is located on the Model 44D's back panel. A GPI is only active when its corresponding pin is connected to system common. GPI 1 is accessible on pin 3 and GPI 2 on pin 4. System common is available on pins 8 and 9. Refer to Figure 3 for connection details.

Pin	Function
1	GPO 1-A
2	GPO 2-A
3	GPI 1
4	GPI 2
5	Aux DC Out
6	GPO 1-B
7	GPO 2-B
8	COM
9	COM

Note:
Connector type on Model 44D is a 9-pin female D-subminiature (DE-9F). Installer must provide a 9-pin male D-subminiature (DE-9M). Connector uses 4-40 threaded inserts for locking with mating plug.

Figure 3. GPI, GPO, and Auxiliary DC Output connections

If the Model 44D has been configured to operate in the tone generator mode the two GPI inputs will not be active. As such, no connections should be made to pins 3 and 4 of the 9-pin connector.

General Purpose Outputs (GPO)

The Model 44D provides two general-purpose output functions that are referred to as GPO 1 and GPO 2. These functions provide contact closures that respond to trigger signals transported over the Dante input (receiver) audio paths. The trigger signals are in the form of high-frequency audio tones (typically 20 kHz) that travel along with the normal audio signals. The normally-open (not shorted) contact closures are isolated from system common. They are provided by solid-state relay contacts which are intended to control low-voltage/low-current DC functions. The contacts are rated for a maximum current of 400 milliamperes and a maximum of 60 volts DC or AC. They are not intended for direct connection to AC mains (high-voltage AC signals.).

Pins on a 9-pin female D-subminiature connector (DE-9F), located on the Model 44D's back panel, allow interfacing with the GPO connections. Two connections are provided for each GPO, pins 1 and 6 for GPO 1 and pins 2 and 7 for GPO 2. Refer to Figure 3 for connection details.

Auxiliary DC Output

A source of low-voltage, low-current DC is available for support of special applications that use the GPO functions. The auxiliary DC output has a nominal voltage of 12 and is referenced to system common. During normal operation the output can range from 10 to 18 volts DC if an external power source is connected to the Model 44D and is providing operating power. Circuitry associated with the auxiliary DC output limits the maximum current to 25 milliamperes. The auxiliary DC output is

accessible by way of pin 5 of the 9-pin female D-subminiature (DE-9F) connector that's located on the Model 44D's back panel. System common is provided on pins 8 and 9. Refer to figure 3 for connection details.

The exact use of the auxiliary DC output will depend on the needs of the specific applications and the capabilities of the installer. The auxiliary DC output can, for example, be connected in series with a GPO's relay contact and used to directly light a status LED, enable an optical coupler, or provide a "GPO active" voltage output. Be careful to limit the load placed on the auxiliary output. Its circuitry will limit the current to 25 milliamperes but keeping it from reaching that maximum value is a good idea.

Configuration

Back-Panel DIP Switches

A 4-position DIP switch assembly, labeled Config, is located on the Model 44D's back panel. The switches are used to set operating parameters, including line input nominal level, line output nominal level, low-pass filter on/off status, and operating mode.

Line Input Nominal Level

Switch SW1 is used to configure the nominal level of the Model 44D's two line input channels. When SW1 is in its off (down) position the line inputs are configured such that connecting an analog signal at a level of +4 dBu will result in a digital signal at -20 dBFS being present on the corresponding Dante output (transmitter) channel. This would allow compatibility

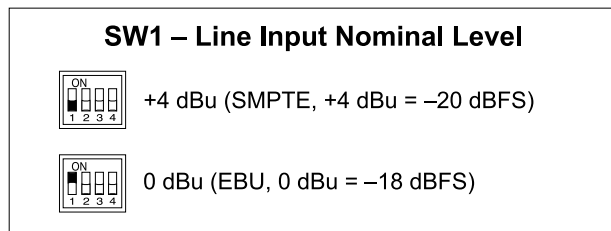

Figure 4. Analog inputs nominal level configuration switch

with SMPTE standards. When SW1 is in its up (on) position connecting an analog signal at a level of 0 dBu will result in a digital signal at -18 dBFS being present on the corresponding Dante output channel. This is compliant with EBU standards.

The choices provided by SW1 are primarily intended to allow the Model 44D's line input gain structure to be matched to the needs of specific applications. Most North American (SMPTE) applications will follow +4 dBu in the analog domain being equal to -20 dBFS in the digital domain. While in Europe (EBU) it would be typical in modern installations for 0 dBu (analog) to be equal to -18 dBFS (digital).

But SW1 can be used as a coarse level adjustment function if necessary. In a SMPTE-compliant installation (+4 dBu = -20 dBFS) setting SW1 to its on (up) position will provide a 6 dB increase in input sensitivity. This could be useful if the average level of the signal connected to the line inputs was a little low. And in an EBU application setting SW1 to its off (down) position would provide a 6 dB decrease in input sensitivity. This could be useful if the analog signals connected to the line inputs were especially "hot."

Line Output Nominal Level

Switch SW2 is used to configure the nominal level of the Model 44D's two line output

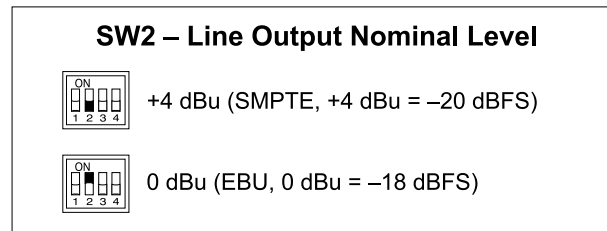

Figure 5. Analog outputs nominal level configuration switch

channels. When SW2 is in its off (down) position the line outputs are configured such that a Dante input (receiver) channel with a signal level of -20 dBFS will result in an analog signal at the corresponding line output channel having a level of +4 dBu. This configuration would allow compatibility with SMPTE digital-to-analog level-relationship standards. When SW2 is in its up (on) position a Dante input (receiver) with a signal level of -18 dBFS will result in an analog signal at the corresponding line output channel having a level of 0 dBu. This relationship will make the line output compliant with EBU standards.

The choices provided by SW2 are primarily intended to allow the Model 44D's line output gain structure to match the needs of specific applications. Most North American (SMPTE) applications will follow -20 dBFS in the digital domain being equal to +4 dBu in the analog domain. While in Europe (EBU) it would be typical in modern installations for -10 dBFS (digital) to be equal to 0 dBu (analog).

SW2 can be used as a coarse level adjustment function if necessary. In a SMPTE-compliant installation (-20 dBFS = +4 dBu) setting SW2 to its on (up) position will provide a 6 dB decrease in input sensitivity. This could be useful if it's desirable for the average level of the line output signals to be less than typical.

This can be useful when a true “+4 dBu” output is simply too “hot.” And in an EBU application setting SW2 to its off (down) position would provide a 6 dB increase in input sensitivity. This could be useful if the average level on the Dante input (receiver) channels is lower than expected and a “hotter” analog output is desirable.

Low-Pass Filters

Switch SW3 allows a low-pass filter function to be enabled or disabled as desired. The function consists of four digital filters, two applying to the audio signals from the line inputs and two applying to the signals destined for the line outputs. When active the filters will eliminate most of the audio content above 10 kHz that enters the Model 44D by way of the line inputs and exits the Model 44D by way of the line outputs. When SW3 is in its off (down) position the low-pass filters are disabled. Full bandwidth audio signals will pass through the Model 44D’s line inputs and line outputs.

When SW3 is in its on (up) position the low-pass filters will be enabled. Enabling the low-pass filters can improve the performance and possibly the intelligibility of audio signals that consist mainly of voice content. In this case audio content in the extend high-frequency range will typically provide little enhancement to system

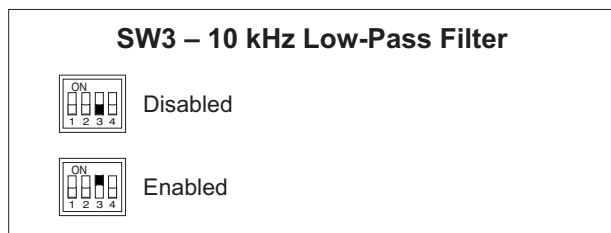

Figure 6. 10 kHz low-pass filter configuration switch

performance and can often contain extraneous noise or other unwanted artifacts. Also, in situations where a Model 44D’s GPO functions are used, enabling the low-pass filters will prevent the signaling tones (typically 20 kHz) from being part of the signals that are presented on the line outputs.

Operating Mode

Switch SW4 is used to configure the Model 44D’s operating mode. When SW4 is in its off (down) position the Model 44D functions as an audio interface. This would be considered its normal mode of operation. When SW4 is in its on (up) position the tone generator mode is selected. In the tone generator mode the Model 44D generates 18 kHz and 20 kHz sine-wave tones. Analog output 1 and Dante transmitter (output) channel 1 will have a continuous source of 18 kHz present. Analog output 2 and Dante transmitter (output) channel 2 will have a continuous source of 20 kHz present.

Note that the frequencies described (18 kHz and 20 kHz) are effective when the Dante sample rate is configured for 48 kHz. When the Dante sample rate is 44.1 kHz, the tone generator output frequencies will be 16.5375 kHz and 18.375 kHz, respectively.

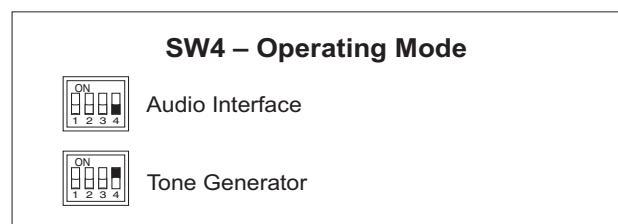

Figure 7. Operating mode configuration switch

Dante Configuration

To integrate the Model 44D into an audio interface application several Dante-related parameters can be configured. At a minimum, signals must be routed to the two Dante input (receiver) channels and from the two output (transmitter) channels. The configuration settings will be stored in non-volatile memory within the Model 44D's circuitry. As such, power-down and power-up activities will not impact the unit's settings. The Model 44D uses the Ultimo 2-input/2-output integrated circuit to implement the Dante architecture.

The two Dante receiver channels will be assigned to the desired Dante transmitter channels on other devices. The two transmitter channels associated with the Model 44D's Dante interface must be assigned to the desired destinations (Dante receiver channels on associated devices). This will typically be done with the Dante Controller software application which is available for download free of charge at audinate.com. Versions are available to support Windows® and OS X® operating systems. Within Dante Controller a "subscription" is the term used for routing a transmitter flow (a group of output channels) to a receiver flow (a group of input channels). Note that as of the writing of this guide the Ultimo integrated circuit limits the number of Dante flows to two. These can either be unicast, multicast, or a combination of the two.

The Model 44D has a default Dante device name of **ST-M44D** followed by a unique suffix. The suffix identifies the specific Model 44D that is being configured. The suffix's actual alpha and numeric characters relate to the MAC address of the Ultimo integrated circuit that's present in the

specific Model 44D. The two Dante receiver (input) channels have the default names of **Ch1** and **Ch2**. The two Dante transmitter (output) channels also have the default names of **Ch1** and **Ch2**. Using Dante Controller these names can be revised as appropriate for the specific application.

The Model 44D supports audio sample rates of 44.1 and 48 kHz with no pull-up/pull-down values available. The desired configuration can be made using the Dante Controller software application. The Model 44D can serve as the clock master for a Dante network but in most cases that would not be optimal.

Switch SW4, located on the back panel, is used to configure Model 44D's operating mode. When selected for the tone generator mode (SW4 on (up)) normal audio interface operation will not take place. The unit's internal processor will generate two sine-wave audio signals (tones). The two Dante transmitter (output) channels should be assigned to the desired destinations. The two Dante transmitter (output) channels will have the default names of **18kHz** and **20kHz**. Signals routed to the two Dante input (receiver) channels will not cause any Model 44D activity to take place. The two Dante receiver (input) channels will have the default names of **Ch1-Inactive** and **Ch2-Inactive**.

Note that the frequencies described (18 kHz and 20 kHz) are effective when the Dante sample rate is configured for 48 kHz. When the Dante sample rate is 44.1 kHz, the tone generator output frequencies will be 16.5375 kHz and 18.375 kHz, respectively. The default names will not change.

Operation

At this point the Model 44D should have its Ethernet, line input, line output, and GPI/GPO connections implemented as desired for the application. Depending on the capabilities of the Ethernet connection an external 12 volt DC power connection may have also been made. The two Dante transmitter (output) channels and two Dante receiver (input) channels should have been routed using the Dante Controller software application. Normal operation of the Model 44D can now begin.

The Model 44D is designed for continuous operation with no adjustments required. Maintaining the correct signal levels coming into the line inputs and Dante receiver channels is important. This will ensure that proper signal levels are presented to the Model 44D's circuitry and associated equipment, leading to optimal audio performance. The audio level meters and GPO status LEDs will provide assistance in confirming that correct operation is taking place.

Initial Operation

The Model 44D will begin its initial functioning a few seconds after its power source is connected. As previously discussed, the unit's power source can be provided by Power-over-Ethernet (PoE) or an external source of 12 volts DC. If both are connected the PoE source will power the unit. Should PoE power subsequently no longer be available, uninterrupted operation will continue using the external 12 volt DC source. (This will probably prove to be a "hollow" victory since a loss of PoE will probably also mean a loss of the required Ethernet data connection!)

Upon Model 44D power up the status LEDs will light in various manners. The PoE, Dante, and Ethernet status LEDs, located on the back panel, will light in various ways. On the front panel the input power, GPO status, and audio level meter LEDs will light in a sequence. Once the test sequence has completed the two columns of level meter LEDs associated with the line outputs will momentarily display the version number of the unit's application firmware (embedded software). Details on how to "read" the version number are provided in the Technical Notes section.

The Model 44D will now begin normal operation. The way in which the back-panel LINK/ACT, SYS, SYNC, and PoE LEDs light will depend on the characteristics of the connected Ethernet signal and the configuration of the unit's Dante interface. Details will be covered in the next paragraph. The user is presented on the front panel with two input power status LEDs, two GPO status LEDs, and four 5-segment LED audio level meters. These resources are simple to understand and should prove to be useful as will be highlighted in the following paragraphs.

Ethernet, PoE, and Dante Status LEDs

Four status LEDs are located below the etherCON connector on the Model 44D's back panel. The LINK/ACT LED will light green whenever an active data connection to a 100 Mb/s Ethernet network has been established. It will flash on and off in response to data packet activity. The PoE LED will light green whenever Power-over-Ethernet (PoE) associated with the connected Ethernet signal is providing operating power for the Model 44D. The SYS

and SYNC LEDs display the operating status of the Dante interface and associated audio-over-Ethernet network. The SYS LED will light red upon Model 44D power up to indicate that the Dante interface is not ready. After a short interval it will light green to indicate that it is ready to pass audio data with another Dante device. The SYNC LED will light red when the Model 44D is not synchronized with a Dante network. It will light solid green when the Model 44D is fully synchronized with a Dante network and an external clock source (timing reference) is being received. It will slowly flash green if this specific Model 44D is serving as the clock master for the Dante network.

How to Identify a Specific Model 44D

The Dante Controller software application offers an identify command that can be used to help locate a specific Model 44D. When identify is selected for a specific unit its audio level meter LEDs will light in a unique pattern. In addition, the SYS and SYNC LEDs, located directly below the etherCON connector on the back panel, will slowly flash green. After a few seconds the LED identification patterns will cease and normal Model 44D level meter and Dante status LED operation will again take place. Audio performance will not be impacted by the use of the identify command. As such it's perfectly acceptable to use the identify command any time it would be useful.

Line Inputs

The Model 44D's two line inputs are electronically balanced (differential), capacitor coupled, with a nominal impedance of 20 k ohms. The nominal analog level of signals presented to the line inputs should match

the Model 44D's configuration. If the nominal input level is configured for -20 dBFS this will equate to a nominal analog input level of $+4$ dBu. If the nominal input level is configured for -18 dBFS this will equate to a nominal input level of 0 dBu. As such, if the nominal level of the Dante output (transmitter) channels is 6 dB different than expected, either high or low, a user should confirm that the Model 44D's input configuration has been set correctly.

The line input circuitry is protected from damage should a moderate DC voltage be accidentally connected. For example, no damage will occur if a powered analog party-line intercom circuit (typically 28 to 32 volts DC from 3-pin XLR pin 2 to pin 1) be accidentally connected. This protection would also be effective should P48 phantom power associated with a microphone signal be accidentally connected.

The frequency response of the line inputs will depend on the configuration of the low-pass filter function. If the filter is enabled most energy above 10 kHz will be removed. This will be effective for voice-applications such as intercom or talent cueing (IFB). If support for high-quality, full-bandwidth audio is necessary ensure that the low-pass filter function has been disabled. This will also apply if 20 kHz nominal "call light" or signaling tones need to pass through the Model 44D's line input to the Dante output (transmitter) channels.

Line Outputs

The line outputs are electronically balanced (differential) and intended to be connected to various analog inputs with nominal impedances of 2 k (2000) ohms or greater. The nominal analog level of

signals present on the line outputs will depend on the Model 44D's configuration. If the nominal output level is configured for -20 dBFS this will equate to a nominal analog output level of $+4$ dBu. If the nominal output level is configured for -18 dBFS this will equate to a nominal output level of 0 dBu. As such, if the nominal analog output level is 6 dB different than expected, either high or low, a user should confirm the Model 44D's configuration.

No special precautions are necessary when using the line outputs in settings where a variety of signals are present. As with the line inputs, the line output circuitry is protected from damage. For example, no damage will occur if a powered analog party-line intercom circuit or a microphone signal with P48 phantom power present be accidentally connected.

Similar to the line inputs, the frequency response of the line output will depend on the configuration of the low-pass filter function. If the filter is enabled most energy above 10 kHz will be removed. This will be effective for voice-applications such as intercom or talent cueing (IFB). If support for high-quality, full-bandwidth audio is necessary ensure that the low-pass filter function has been disabled. This will also apply if 20 kHz nominal "call light" or signaling tones need to pass from the Model 44D's Dante receiver inputs to the line outputs.

Level Meters

The Model 44D contains four 5-segment LED level meters, two associated with the line inputs and two associated with the line outputs. The meters are provided as a support aid during installation, configuration, operation, and troubleshooting.

General

The meters are organized into two groups with one group representing the two line inputs and the second group representing the two line outputs. The two meters associated with the line inputs are calibrated in reference to the configuration of the nominal level of the line inputs. When configured for $+4$ dBu nominal a meter's 0 LED lighting will indicate that an analog signal with a level of $+4$ dBu is present on the associated line input. This would translate to an output (transmitter) level of -20 dBFS being sent to the Dante network. When the line inputs are configured for 0 dBu nominal a meter's 0 LED lighting will indicate that a signal with a 0 dBu is present on the line input and the corresponding Dante output (transmit) level will be -18 dBFS.

Similar to the line inputs, the two meters associated with the line outputs are calibrated in reference to the configuration of nominal level of the line outputs. When configured for $+4$ dBu nominal a meter's 0 LED lighting will indicate that a Dante input (receiver) level of -20 dBFS is present along with a corresponding signal on the line output with a level of $+4$ dBu. When the line outputs are configured for a 0 dBu nominal level a meter's 0 LED lighting will indicate that a Dante input (receiver) level of -18 dBFS is present. And the corresponding analog output signal present on the line output will have a level of 0 dBu.

Each level meter contains four green LEDs and one yellow LED. The four green LEDs indicate audio signal levels at or below the selected nominal level ($+4$ dBu or 0 dBu). The top LED is yellow and indicates a signal that is 6 dB or greater than the selected nominal level. An audio signal that causes the yellow LED to light doesn't necessarily

indicate an excessive level condition, but it does provide a warning that at some stage reducing the signal level of the source may be prudent. Typical operation with normal signal levels should find the meters lighting near their “0” point. Signal peaks may cause the yellow LEDs to flash. But a yellow LED that lights fully during normal operation will typically indicate excessive signal level and/or a configuration problem with associated Dante-enabled equipment.

Non-Optimal Signal Levels

If the meters consistently display levels that are lower or higher than 0 it’s possible that a configuration issue exists. This would typically be related to an incorrect Model 44D line input or line output configuration or an incorrect setting on the equipment associated with the Model 44D. With a digital matrix intercom system providing the Dante input signal this problem could be due to an incorrect configuration having been made to its specific channel or port. For example, the RTS ADAM system has a published nominal level of +8 dBu, but it’s not clear how this translates into a digital audio level on an associated OMNEO (Dante-compatible) port. Using its configuration software it’s most likely possible to set the nominal level of intercom key panels or ports to something different than +8 dBu. The best solution in this case would be to adjust the associated OMNEO (Dante-compatible) port such that it results in a nominal level that matches the Model 44D’s configuration. So, for example, if the Model 44D is configured for +4 dBu nominal input levels then the associated OMNEO (Dante) transmitter channels should be set up to be the same. This should lead to the optimal performance of the Model 44D and the associated intercom system.

GPI/GPO

Whether or not the general-purpose inputs (GPI) and general-purpose outputs (GPO) functions are implemented will depend on the needs of the specific application. If the appropriate connections are made using the 9-pin D-subminiature connector either or both functions can be utilized. No user-action is required for the functions to be active. There is no user indication when a GPI input has been activated. Two front-panel LEDs will indicate when a signal on the Dante receiver input has been recognized as a GPO.

A typical application might find two Model 44D units communicating with each other. For clarity, we’ll call them Unit A and Unit B. An analog audio signal connected to input 1 on Unit A will be transported via Dante to Unit B and then sent out Unit B’s line output 1. Signals connected to the line inputs on Unit B will end up on the line outputs of Unit A. How the GPI and GPO functions will be similar. Activating GPI 1 on Unit A will result in activation of Unit B’s GPO 1. This condition will be noted by the GPO 1 LED lighting on Unit B. Closures on Unit B’s GPI 1 and GPI 2 will result in activation of Unit A’s GPO outputs and associated LEDs.

Advanced applications may use a Model 44D unit to interface analog audio, GPI, and GPO signals associated with intercom or broadcast routers with Studio Technologies’ Model 45DC or Model 45DR intercom interfaces. Since the three units (44D, 45DC, and 45DR) all use 20 kHz tones for signaling direct compatibility between GPI, GPO, and party-line intercom call-light functions is possible.

Tone Generator

Switch SW4, located on the back panel, is used to configure Model 44D's operating mode. When selected for the tone generator mode (SW4 on (up)) normal audio interface operation will not take place. The unit's internal processor will generate two sine-wave audio signals (tones).

The frequencies described are effective when the Dante sample rate is configured for 48 kHz. When the Dante sample rate is 44.1 kHz, the tone generator output frequencies will be 16.5375 kHz and 18.375 kHz, respectively.

The unit will function in this manner:

- An 18 kHz tone at a nominal level of +4 dBu will be present on analog line output channel 1.
- A 20 kHz tone at a nominal level of +4 dBu will be present on analog line output channel 2.
- An 18 kHz tone at a level of –20 dBFS will be present on Dante transmitter (output) channel 1.
- A 20 kHz tone at a level of –20 dBFS will be present on Dante transmitter (output) channel 2.
- The two line output meters on the Model 44D's front panel will display a constant value of 0.
- The Dante transmitter (output) channels will have names of **18kHz** and **20kHz**.
- The Dante receiver (input) channels will have names of **Ch1–Inactive** and **Ch2–Inactive**.
- The two analog line input channels on the Model 44D's back panel will not be active.

- The two Dante receiver (input) channels will not be active.
- The two line input meters on the Model 44D's front panel will not light.
- The two GPI functions will not be active.

Technical Notes

IP Address Assignment

By default the Model 44D's Ethernet interface will attempt to automatically obtain an IP address and associated settings using DHCP (Dynamic Host Configuration Protocol). If a DHCP server is not detected an IP address will automatically be assigned using the link-local protocol. This protocol is known in the Microsoft® world as Automatic Private IP Addressing (APIPA). It is also sometimes referred to as auto-IP (PIPPA). Link-local will assign an IP address in the IPv4 range of 169.254.0.1 to 169.254.255.254. In this way multiple Dante-enabled devices can be connected together and automatically function, whether or not a DHCP server is active on the LAN. Even two Dante-enabled devices that are directly interconnected using an RJ45 patch cord will, in most cases, correctly acquire IP addresses and be able to communicate and transport audio. An exception does arise when trying to directly interconnect two Dante-enabled devices that use the Ultimo Dante implementation, such as two Model 44D units. An Ethernet switch is required to provide the Ethernet ports to correctly interconnect two Ultimo-based devices directly with each other. (The technical reason relates to the need for the slight latency provided by an Ethernet switch.)

Using the Dante Controller software application the Model 44D’s IP address and related network parameters can be set for a fixed (“static”) configuration. While this is a more-involved process than simply letting DHCP or link-local “do their thing,” if fixed addressing is necessary then that capability is available. But in this case it’s highly recommended that each unit be physically marked, e.g., directly labeled using a permanent marker or “console tape,” with its specific IP address. If knowledge of a Model 44D’s IP address has been misplaced there is no reset button or other method to easily restore the unit to a default IP setting.

In the unfortunate event that a device’s IP address is “lost,” the Address Resolution Protocol (ARP) networking command can be used to “probe” devices on a network for this information. For example, in Windows OS the **arp -a** command can be used to display a list of LAN information that includes MAC addresses and corresponding IP addresses. The simplest means of identifying an unknown IP address is to create a “mini” LAN with a personal computer connected directly to the Model 44D. Then by using the appropriate ARP command the required “clues” can be obtained.

Optimizing Network Performance

For best Dante audio-over-Ethernet performance a network that supports VoIP QoS capability is recommended. This can typically be implemented on virtually all contemporary managed Ethernet switches. There are even specialized switches that are optimized for entertainment-associated applications. Refer to the Audinate website (audinate.com) for details on optimizing networks for Dante applications.

Application Firmware Version Display

As part of the Model 44D’s power-up sequence the unit’s application firmware version number is displayed. This is useful when working with factory personnel on application support and troubleshooting situations. The five LEDs associated with the line output channel 1 meter are used to display the major release number with a range of 1 through 5. The five LEDs associated with the line output channel 2 meter are used to display the release sub-number which ranges from 1 through 5. Refer to Figure 8 for a detailed view of the LEDs and the corresponding application firmware version numbering scheme.

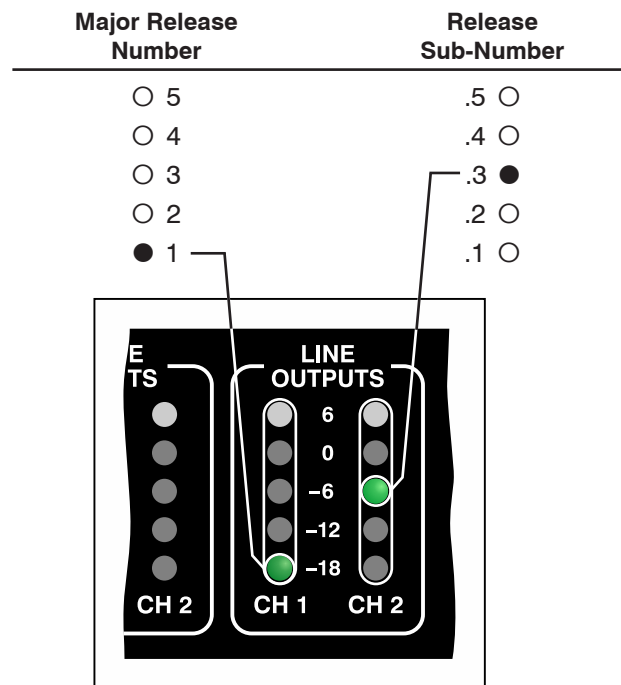

Figure 8. Detail of front panel showing the status LEDs that display the application firmware version. In this example, the application firmware version is 1.3.

Application Firmware Update Procedure

It's possible that updated versions of the application firmware (embedded software) that runs the Model 44D's microcontroller (MCU or processor) integrated circuit will be released to add features or correct issues. Refer to the Studio Technologies' website for the latest application firmware file. The unit has the ability to automatically load revised files into the MCU's non-volatile memory by way of its USB interface. The Model 44D implements a USB host function that directly supports connection of a USB flash drive. The Model 44D's MCU updates using a file named **M44D.bin**.

The update process begins by preparing a USB flash drive. The flash drive doesn't have to be empty (blank) but must be in the personal-computer-standard FAT32 format. The new firmware file will be saved in the root directory with a name of **M44D.bin**. Studio Technologies will supply the application firmware file inside a .zip archive file. While the firmware file inside of the zip file will adhere to the naming convention required by the Model 44D, the name of the zip file itself will include the file's version number. For example, a file named **M44Dv1r3MCU.zip** would indicate that version 1.3 of the application firmware (**M44D.bin**) is contained within this zip file. Once the desired **M44D.bin** file has been stored in the root directory the flash drive will be ready for use.

To install the application firmware file follow these steps:

1. Remove power from the Model 44D. This will entail removing the Ethernet connection if it is providing PoE power or removing the external source of 12 volts DC if that is being used. (Both must be disconnected if for some reason dual-power has been implemented.)
2. Remove the cover from the Model 44D's enclosure. Begin by removing the four 5/64 hex head screws and internal tooth lock washers, two per side. Be certain to save the screws and lock washers so that re-assembly will be fast and painless. Then carefully remove the cover. Locate the USB connector on the main circuit board. It's in the rear of the unit, adjacent to the connector used for line output channel 2. Also on the circuit board and adjacent to the USB connector is a very small LED indicator.
3. Insert the prepared USB flash drive into the USB connector.
4. Apply power to the Model 44D. Power can be provided by Power-over-Ethernet (PoE) associated with a connected Ethernet signal or from an external 12 volt DC source.
5. The Model 44D will run a "boot loader" program that will immediately load the new application firmware file (**M44D.bin**). This process will take only a few seconds. During this time period the LED adjacent to the USB connector will flash slowly on and off green. Once the entire loading process is over, taking approximately 10 seconds, the Model 44D will restart using the newly-loaded application firmware.
6. At this time the Model 44D is functioning with the newly-loaded application firmware and the USB flash drive can be removed. But to be conservative, remove the power first and then remove the USB flash drive.

7. Replace the cover and secure it using the previously removed screws and lock washers.
8. Apply power to the Model 44D and “read” the application firmware version number by observing the two meters associated with the line outputs. Ensure that this is the desired version.

Note that upon power being applied to the Model 44D if the USB flash drive doesn't have the correct file (**M44D.bin**) in the root folder no harm will occur. Upon power up the green LED adjacent to the USB connector will flash on and off rapidly for a few seconds to indicate that a valid file was not found and then normal operation using the unit's existing application firmware will begin.

Ultimo Firmware Update

As previously discussed, the Model 44D implements Dante connectivity using the 2-input/2-output Ultimo integrated circuit from Audinate. The Dante Controller software application can be used to determine the version of the firmware (embedded software) residing in the Ultimo “chip.” This firmware can be updated by way of the Model 44D's Ethernet connection. The latest Dante firmware file is available on the Studio Technologies' website. The Dante Firmware Update Manager application is used to install the firmware. This program is also available for download on the Studio Technologies' website (studio-tech.com).

Specifications

Power Sources:

Power-over-Ethernet (PoE): class 1 (very low power, ≤ 3.84 watts) per IEEE 802.3af

External: 10 to 18 volts DC, 0.3 amp maximum at 12 volts DC

Network Audio Technology:

Type: Dante audio-over-Ethernet

Bit Depth: up to 24

Sample Rates: 44.1 and 48 kHz

Number of Receiver (Input) Channels: 2

Number of Transmitter (Output) Channels: 2

Dante Audio Flows: 4; 2 receiver, 2 transmitter

Network Interface:

Type: twisted-pair Ethernet, Power-over-Ethernet (PoE) supported

Data Rate: 100 Mb/s (10 Mb/s not supported; 1000 Mb/s “GigE” Ethernet not supported unless falls back to 100 Mb/s)

Line Inputs: 2

Type: analog, electronically balanced, capacitor coupled

Impedance: 20 k ohms, nominal

Nominal Level: +4 dBu, reference -20 dBFS or 0 dBu, reference -18 dBFS, configurable

Maximum Level: +24 dBu when configured for +4 dBu nominal, +18 dBu when configured for 0 dBu nominal

Dynamic Range: >114 dB, A-weighted

Distortion (THDS+N): <0.002% (-95 dB), measured at -1 dBFS, 22 kHz bandwidth

Frequency Response: +0.0 dB/-0.5 dB, 20 Hz to 20 kHz; 10 kHz low-pass filters disabled

Low-Pass Filters: -3 dB @ 10 kHz, -55 dB @ 20 kHz, configurable on or off in tandem with line output filters

Line Outputs: 2

Type: analog, electronically balanced, capacitor coupled, intended to drive balanced or unbalanced loads of 2 k ohms or greater.

Source Impedance: 200 ohms

Nominal Level: +4 dBu, reference -20 dBFS, or 0 dBu, reference -18 dBFS, configurable

Maximum Level: +24 dBu when configured for +4 dBu nominal, +18 dBu when configured for 0 dBu nominal

Dynamic Range: >114 dB, A-weighted

Distortion (THDS+N): 0.003% (-90 dB), measured at -1 dBFS, 22 kHz bandwidth

Frequency Response: ± 0.1 dB, 20 Hz to 20 kHz, 10 kHz low-pass filter disabled

Low-Pass Filters: -3 dB @ 10 kHz, -55 dB @ 20 kHz, configurable on or off in tandem with line input filters

Tone Generator:

Type: sine-wave

Frequency: 18 kHz ± 350 mHz; 20 kHz ± 350 mHz at 48 kHz sample rate (16.5375 kHz and 18.375 kHz at 44.1 kHz sample rate)

Analog Output Level: +4 dBu, nominal

Analog Output Distortion (THD+N): <0.003%

Digital Output Level (Dante transmitter (Output)): -20 dBFS

Digital Output Distortion (THD+N): <0.0001%

Meters: 4

Function: displays level of line inputs and line outputs in dBFS

Type: 5-segment LED, modified VU ballistics

GPI: 2

Type: logic input, pulled to +3.3 volts DC through 3.3 k (3300 ohm) resistor, pull down to common to enable

Signaling Method: tones summed into Dante transmitter audio path, 20 kHz nominal at 48 kHz sample rate, 18.375 kHz nominal at 44.1 kHz sample rate

GPO: 2

Output Type: solid-state relay contact

Contact Type: form A (normally open, not shorted), isolated

Contact Rating: 400 mA, 60 volts AC/DC, maximum

Contact Resistance: 2 ohms, maximum

Detection Method: monitors Dante receiver audio path for presence of 20 kHz (± 800 Hz) tone at 48 kHz sample rate, 18.375 kHz (± 800 Hz) tone at 44.1 kHz sample rate. Tones will pass to line outputs unless low-pass filters enabled.

GPO Status LEDs: 2

Auxiliary DC Output:

Application: for use with GPO outputs

Type: 12 volts DC, nominal, 10-18 volts DC with external power connected, 25 mA maximum

Connectors:

Line Inputs: 3-pin female XLR

Line Outputs: 3-pin male XLR

Ethernet: Neutrik etherCON RJ45

External DC: 4-pin male XLR

GPI/GPO/Aux DC: 9-pin female D-subminiature (DE-9F)

USB: type A receptacle (located inside Model 44D's enclosure and used only for application firmware updates)

Dimensions – Overall:

8.7 inches wide (22.1 cm)

1.72 inches high (4.4 cm)

8.3 inches deep (21.1 cm)

Mounting Options: single-unit and dual-unit rack-mount front panels; uses one space (1U) in a standard 19-inch rack

Weight: 1.8 pounds (0.80 kg); rack-mount front panels add 0.2 pounds (0.09 kg)

Specifications and information contained in this User Guide subject to change without notice.

Appendix A: Original vs Updated Model 44D

Differences Between Original and Updated Model 44D Units

This user guide is intended primarily to support Model 44D units with serial numbers of M44D-01151 and later. These “updated” units incorporate several changes made to the “original” Model 44D units that were first shipped by Studio Technologies. The original units had serial numbers in the range of M44D-00151 through 00250. This appendix will provide details on the differences between the original and the updated units, allowing users to successfully use both. But it’s first important to note that the technical performance of the original and the updated units are exactly the same. Audio performance is equally excellent, the feature set is identical, and the ability to update the unit’s application firmware remains the same.

On the original Model 44D the GPI, GPO, and auxiliary DC output functions are accessible using a 10-pin “header” connector that is located on the main printed circuit board assembly. This connector is only accessible by removing the unit’s cover. Interfacing with these three functions requires the addition of a ribbon-cable assembly that links the

10-pin header with devices located outside of the Model 44D’s enclosure. While fabricating such a cable, or obtaining one from Studio Technologies, is not a difficult task, it’s far from optimal. The ribbon cable will have to exit the enclosure between the top of the back panel and the cover and then terminates the functions on a connector that hangs loosely onto the end of the ribbon cable.

To improve access to the GPI, GPO, and auxiliary DC output functions the updated Model 44D design (serial number M44D-01151 and later) adds a 9-pin subminiature female (DE-9F) connector to the back panel. In this way the three functions are now directly accessible using a mating connector that utilizes a standard 9-pin male D-subminiature (DE-9M) plug. This is nice change but doesn’t come without a cost. To allow physical space for the 9-pin connector on the back panel, the USB interface connector was moved to a location on the main circuit board. The cover must be removed to provide access to the USB interface connector.

Details regarding the differences between the original and the updated Model 44D units are provided in the following paragraphs.



Figure 9. Back view of “original” Model 44D unit with serial numbers 00151-00250 (left) and “updated” Model 44D unit with serial numbers 01151-later (right)

GPI, GPO, and Auxiliary DC Output

Access to the GPI, GPO, and auxiliary DC output functions on the original units requires the use of an interface cable assembly. One end of the interface cable requires a 10-conductor socket that has two rows of five connectors on 0.1-inch centers. The socket will mate with a 10-pin header that is located on the Model 44D's circuit board. Access requires that the cover be removed. The other end of the interface cable will terminate on the desired mating connector, typically a 9-pin female D-subminiature (DE-9F). It's expected that a 10-conductor 0.050-inch center ribbon cable will be utilized by the interface cable. For details on where the 10-pin header is located refer to Figure 10.

For details on the header's pin connections and related 9-pin D-sub pinout refer to Figure 11.

It's expected that in most cases Model 44D units will be used only to transport audio to and from a Dante network. The GPI, GPO, and auxiliary DC output functions are appropriate for some specialized applications but the use of them will be limited. If a user of an original-vintage Model 44D requires the use of these functions it's certainly possible to access them. A custom interface cable can be fabricated following the information provided in Figures 10 and 11. Alternately, please contact technical support at Studio Technologies for details regarding obtaining a pre-fabricated interface cable.

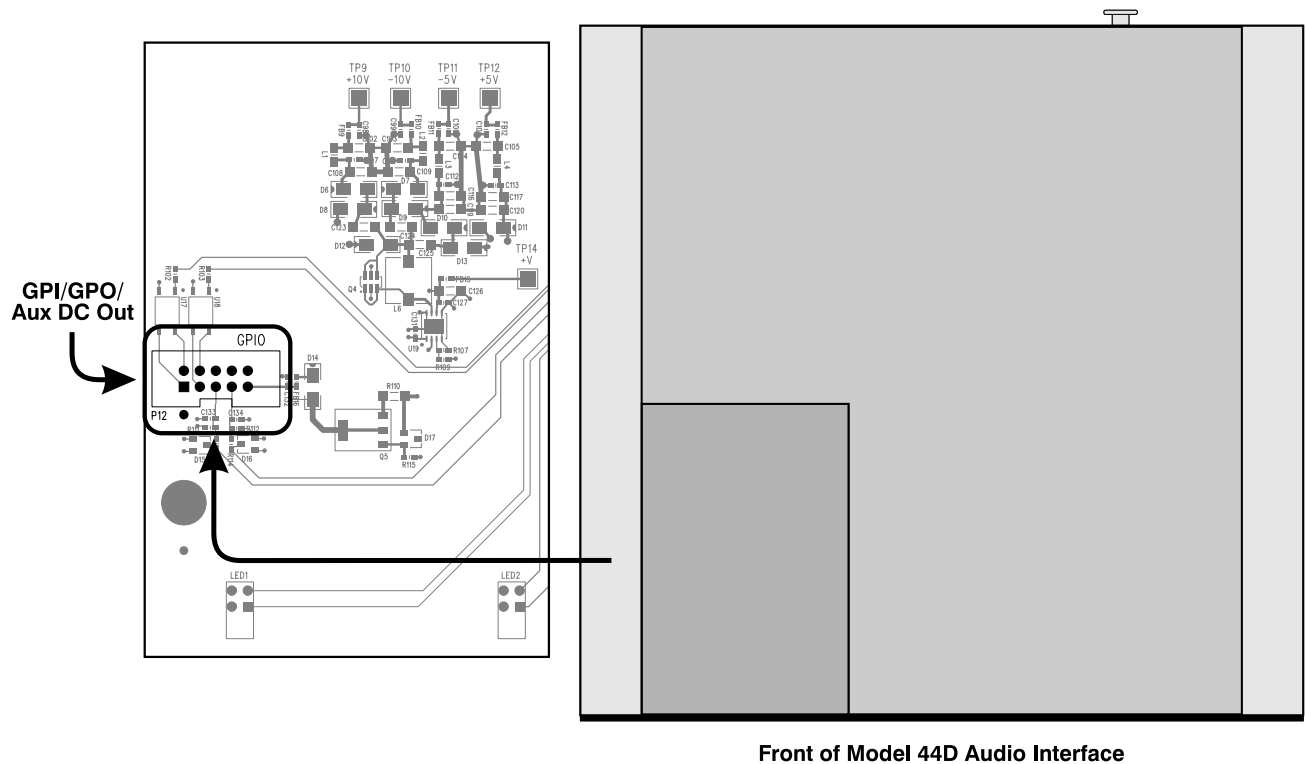

Figure 10. Model 44D GPI/GPO/Aux DC Out 10-pin header location (applies to M44D-00151-00250)

10-Pin Header	DE-9F	Function
1	1	GPO 1-A
3	2	GPO 2-A
5	3	GPI 1
7	4	GPI 2
9	5	Aux DC Out
2	6	GPO 1-B
4	7	GPO 2-B
6	8	COM
8	9	COM
10	---	---

Figure 11. Model 44D GPI/GPO/Aux DC Out 10-pin header and 9-Pin D-sub pinout chart (M44D-00151-00250)

Application Firmware Update Procedure

The application firmware used for original Model 44D units is compatible with that used in the updated Model 44D units.

As such, as newer firmware versions are released they can be directly loaded into units of either type. The only difference is the location of the USB interface connector. Original Model 44D units contained a USB interface connector on their back panel. A USB status LED is located adjacent to this connector. The firmware update procedure instructions provided in this guide for the updated units apply to the original unit as well, with the exception that the cover does not have to be removed. The USB flash drive that contains the desired M44D.bin file will be inserted into the connector on the back panel. So as it relates to loading application firmware, original Model 44D units offer a much simpler means to access the USB interface connector.

Appendix B

Interfacing RTS® Matrix Intercom Systems with the Model 44D Audio Interface

ADAM™ Matrix Intercom System Analog Ports to Model 44D Interface

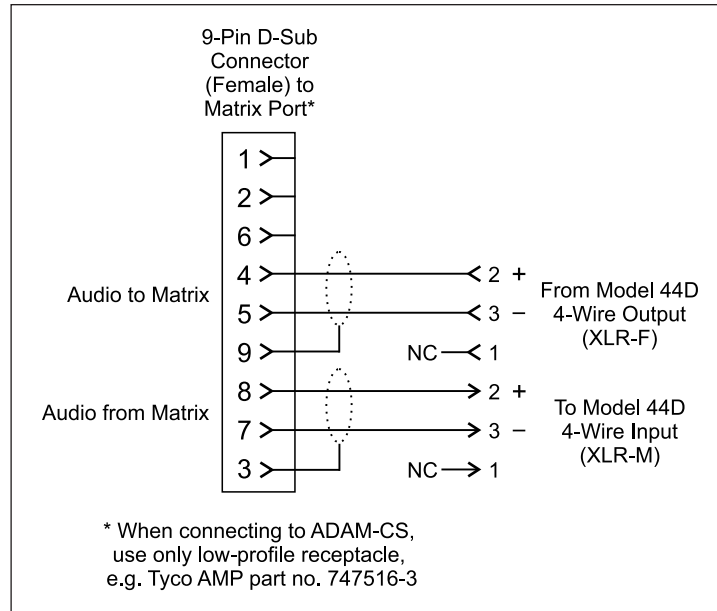

RVON-I/O I/O Connections to Model 44D Interface

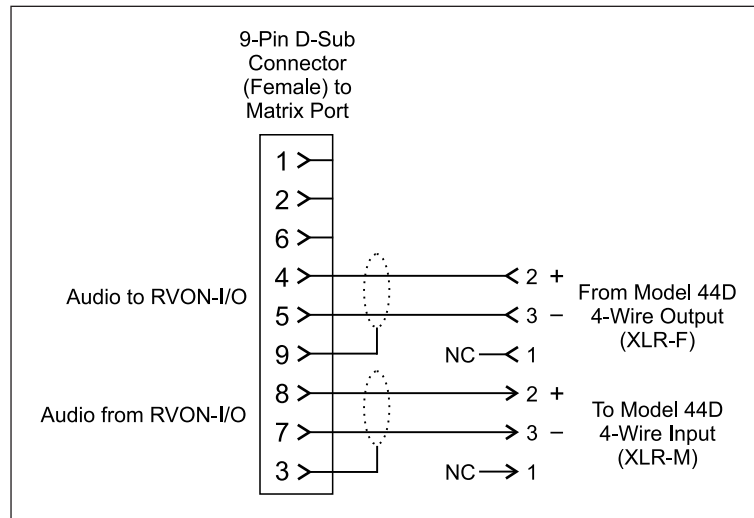

Appendix C

Interfacing Riedel® Artist™ Matrix Intercom System Analog Ports with the Model 44D Audio Interface

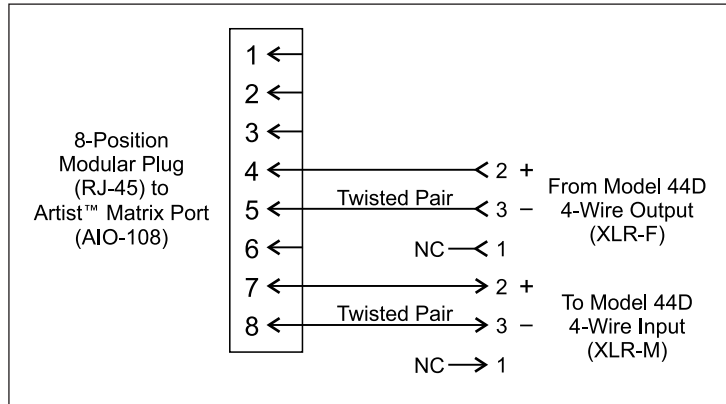

Back Panel Jack on Matrix Chassis

Jack Front View

T568B RJ-45 Wiring

Pin 1	WHT/ORG
Pin 2	ORG/WHT
Pin 3	WHT/GRN
Pin 4	BLU/WHT
Pin 5	WHT/BLU
Pin 6	GRN/WHT
Pin 7	WHT/BRN
Pin 8	BRN/WHT

8-Position Modular Plug (also known as RJ-45)

Plug Top View
(Release Tab on Bottom)

Appendix D

Interfacing Clear-Com® Matrix Intercom System Analog Ports with the Model 44D Audio Interface

