

StudioComm for Surround

Model 761 Central Controller and Model 771 Control Console

User Guide

Issue 1, March 2008

**This User Guide is applicable for systems consisting of:
Model 761: serial number M761-00151 and later with software version 1.02;
Model 771: M771-00151 and later**

© 2008 by Studio Technologies, Inc., all rights reserved
www.studio-tech.com

This page intentionally left blank.

Table of Contents

| | |
|------------------------------|----|
| Introduction..... | 5 |
| Installation | 9 |
| Configuration | 15 |
| Operation..... | 29 |
| Technical Notes | 35 |
| Specifications | 37 |
| Appendix A..... | 38 |
| Block Diagrams | |
| Model 761 Central Controller | |
| Model 771 Control Console | |

This page intentionally left blank.

Introduction

What This User Guide Covers

This User Guide is designed to assist you when installing and using the Model 761 Central Controller and the Model 771 Control Console.

Overview

As production of both 5.1 surround and 2-channel stereo audio material becomes a day-to-day reality, the need for monitoring these sources is imperative for broadcast and post-production facilities. Studio Technologies has addressed this need with the StudioComm for Surround Model 761 Central Controller and Model 771 Control Console. While this system was designed to support the needs of a major television network, it should find a comfortable home in many other applications as well. About the only system features that were selected to directly match this network's requirements are related to the input source/monitor output organization and naming conventions. However this implementation should match the needs of others too. With its digital audio inputs, analog outputs, and Dolby® E dialnorm support, it's a simple task to integrate the system into a variety of facilities. The carefully selected feature set provides the most-needed resources and presents them in a way that remains simple to use. In addition, by using the best of contemporary technology, as well as following rigorous design practices, the system's audio quality is simply excellent.

This version of the StudioComm for Surround system starts with the Model 771 Control Console, the "command center" that is designed to reside at the operator's location. It allows fingertip selection of

all monitoring functions. Numerous LED indicators provide complete status information. A 4-digit numeric display indicates the monitor output or dialnorm level in real time. A major strength of the Model 771 is its ability to configure, under software control, a number of operating parameters. Using a 9-pin cable, the Model 771 connects to a Model 761 Central Controller.

The Model 761 Central Controller occupies just one rack space but allows connection of two 5.1 surround inputs and three 2-channel stereo inputs. In addition, a 5.1 surround and special 2-channel stereo "director cue" monitor output are provided.

All the 5.1 and stereo inputs are digital and are compatible with AES3id sources. These unbalanced digital signals utilize BNC connectors and are ubiquitous in most broadcast and many post-production environments. Sample rates of up to 192 kHz and bit depths of up to 24 are supported. With the system's dynamic range of greater than 106 dB, there isn't a problem ensuring that the quality of all connected audio sources is maintained. The monitor outputs are analog, balanced line level, and have a maximum level of +26 dBu. They include power-up/power-down protection circuitry to help maintain the health of the connected loudspeaker systems.

A source of Dolby E metadata can be connected to the Model 761 Central Controller. This RS-485/RS-422 115.2 kbit/s compatible signal carries numerous data elements, including one that represents the average dialog level of an associated audio program. This dialog normalization or "dialnorm" value is an integral part of many broadcast distribution systems, ending up in the audio playback systems of consumers. Hardware and software within

the Model 761 separates out the dialnorm element that relates to one of the connected 5.1 surround audio sources. This dialnorm level value can then be displayed on the Model 771 Control Console, as well as used to automatically adjust the monitor output level. This provides a unique solution to the broadcast and post-production world, allowing a professional environment to accurately simulate an end user's experience.

Digital audio sources are interfaced with the Model 761 using nine BNC connectors. Analog monitor output signal connections are made using one 25-pin D-subminiature connector. One 9-pin D-subminiature connector is used to link the Model 761 to the Model 771 Control Console. A second 9-pin D-sub connector is used to interface metadata and remote control signals with

the Model 761. An advanced flash-based microcontroller integrated circuit provides the logic "horsepower" for the unit. AC mains power is connected directly to the Model 761, which is factory selected for 100, 120, or 220/240 V operation. The internal power supply utilizes two toroidal mains transformers for quiet audio operation.

Additional Details

The Model 771 provides four buttons and associated LEDs for selection of the input source to be monitored. A total of six sources can be monitored, one being active at a time. Two of the sources are 5.1 surround, while the other four are monaural. For flexibility, one of the 5.1 inputs can be configured to be directly compatible with a 2-channel stereo source.

Figure 1. Model 761 Central Controller Front Panel

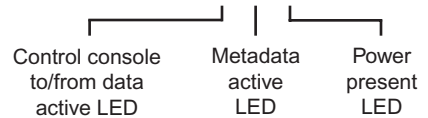
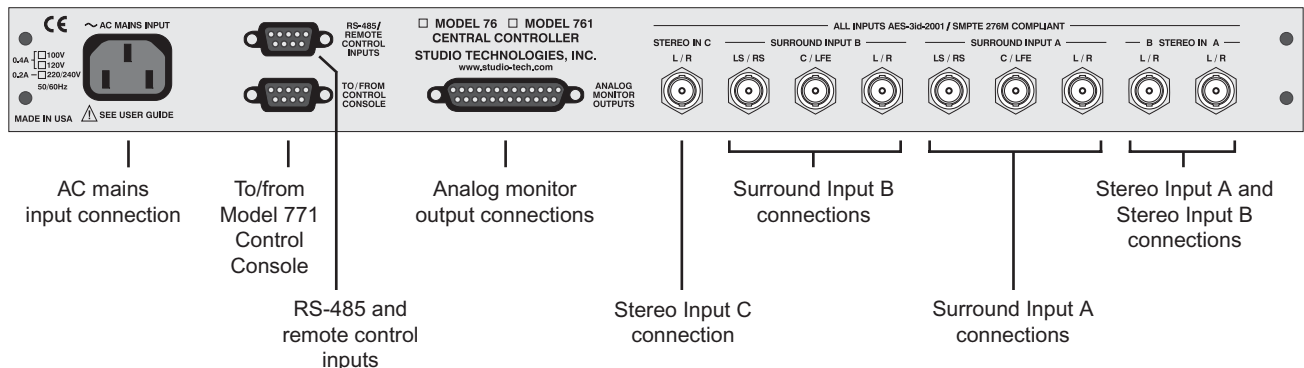

Figure 2. Model 761 Central Controller Back Panel



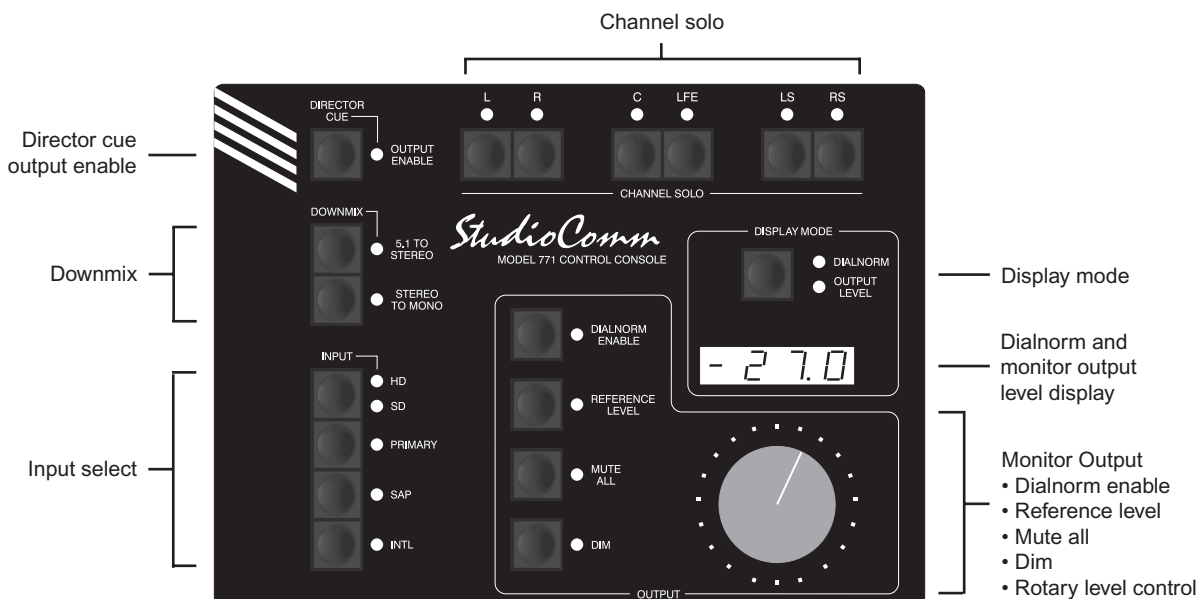

Figure 3. Model 771 Control Console Front Panel

The 5.1 monitor output levels can be controlled by way of a large, easy-to-use rotary control. The level control auto mute all function ensures the monitor output channels automatically mute whenever the rotary level control is in its fully counterclockwise (minimum) position. By using the reference level function, the monitor output level can be set to a pre-configured value. This is provided for audio-with-picture applications which require a specific monitor level. The reference level is easily configured by taking an electronic “snapshot” of the position of the rotary level control. For operator confirmation, a 4-digit LED display shows the level of the monitor output. The display can be configured for either an attenuation mode or a direct db SPL value.

The dim function allows the monitor output level to be reduced by a fixed dB amount. The dim level is selected from four available levels. A mute all function allows all

monitor output channels to be simultaneously muted. The channel solo function allows one or more specific channels to be monitored while the others are automatically muted.

Two functions allow the format of the monitored sources to be checked for level or phase inconsistencies. The 5.1 to stereo downmix function is used to create a stereo signal from the selected 5.1 surround source. The stereo to mono downmix function allows audio on the left and right channels to be added (summed) and monitored on the monitor’s system’s center channel. The two downmix functions can be simultaneously enabled, allowing a 5.1 surround source to be checked for mono compatibility.

A special “director cue” output function is provided. This allows a monaural or stereo input to be connected to the Model 761 Central Controller, which also has

a dedicated 2-channel stereo output associated with it. A button on the Model 771 Control Console allows on/off control of this signal. This is useful when control rooms need to monitor auxiliary audio signals, such as site-event cue signals, through an independent set of loudspeakers. For additional flexibility, two remote control input functions are provided: mute all and dim. By providing access to these functions, talkback or communications activity from an audio console or matrix intercom system can control the level of the system's 5.1 monitor outputs.

The Model 771 Control Console connects to, and is powered by, the Model 761 Central Controller. The interconnecting cable uses 9-pin D-subminiature connectors and carries RS-485 data and DC power. The Dolby E-compatible metadata connects to the Model 761 by way of a second 9-pin D-sub connector. Remote control signals, including mute all and dim, also connect to the Model 771 using the second 9-pin D-sub connector.

Installation

In this section you will be installing the Model 761 Central Controller in an equipment rack. Connections to the digital audio inputs and analog monitor outputs will be made. A location will be selected for the Model 771 Control Console and it will be connected to the Model 761. If applicable, a source of Dolby E metadata may be connected. In addition, external equipment will be interfaced to the remote control inputs. AC mains power will be connected to the Model 761.

System Components

The shipping carton contains one each of the following: Model 761 Central Controller, Model 771 Control Console, 20-foot (6.1 m) 9-pin D-sub interconnecting cable, and user guide. Units destined for North America also include an AC mains cord. Your dealer or distributor should provide an AC mains cord for destinations outside of North American.

Mounting the Model 761

The Model 761 Central Controller requires one space in a standard 19-inch (48.3 cm) equipment rack. Select a location that is convenient for making connections to the digital and analog audio signals as well as to the Model 771 Control Console. A 20-foot (6.1 m) cable is supplied to connect the Model 761 to the Model 771. If the needs of a specific installation dictate, an alternate-length interconnecting cable can be fabricated and used. Secure the Model 761 into the equipment rack using two mounting screws per side.

Audio Connections

Audio signal connections are made by way of multiple BNC jacks and a 25-pin D-subminiature connector which are located on the Model 761's back panel. Refer to Figure 2 for a detailed view of the back panel. The BNC jacks will be used for the digital audio signals. A cable assembly with a 25-pin D-sub plug (male) on one end and the desired connectors on the other end will be used for connecting to the analog monitor outputs.

Digital Audio Inputs

The nine female BNC connectors on the Model 761's back panel are used to interface with digital audio signal sources. Please refer to Figure 4 for details on the supported inputs and the exact connectors to be used.

Note that the input source titles in Figure 4 refer to the button selections on the Model 771 Control Console. It includes support for three input sources each for both SD (standard-definition) and HD (high-definition) programming. For SD the primary source is either 5.1 surround or 2-channel stereo while for HD the primary source is intended to be 5.1 surround. In both SD and HD the SAP (secondary audio program) and INTL (international) inputs are monaural. Of course, technically, all the digital audio inputs on the Model 761 provide the same excellent audio quality. The titles refer only to the intended signal sources.

Each of the available digital audio inputs is intended for connection to an unbalanced digital audio source that is compatible with the AES3id-2001 standard. In broadcast environments these signals may also be referred to as following the SMPTE

SD–Primary

This input selection allows a 5.1 surround or 2-channel stereo audio source to be monitored.

- Left Source:** Channel 1, Surround A L/R input
- Right Source:** Channel 2, Surround A L/R input
- Center Source:** Channel 1, Surround A C/LFE input
- LFE Source:** Channel 2, Surround A C/LFE input
- LS Source:** Channel 1, Surround A LS/RS input
- RS Source:** Channel 2, Surround A LS/RS input

SD–SAP

This input selection allows a mono audio source to be monitored.

- Source:** Channel 1, Stereo A L/R input

SD–INTL

This input selection allows a mono audio source to be monitored.

- Source:** Channel 2, Stereo A L/R input

HD–Primary

This input selection allows a 5.1 surround audio source to be monitored.

- Left Source:** Channel 1, Surround B L/R input
- Right Source:** Channel 2, Surround B L/R input
- Center Source:** Channel 1, Surround B C/LFE input
- LFE Source:** Channel 2, Surround B C/LFE input
- LS Source:** Channel 1, Surround B LS/RS input
- RS Source:** Channel 2, Surround B LS/RS input

HD–SAP

This input selection allows a mono audio source to be monitored.

- Source:** Channel 1, Stereo B L/R input

HD–INTL

This input selection allows a mono audio source to be monitored.

- Source:** Channel 2, Stereo B L/R input

Director Cue

This input selection allows a 2-channel stereo audio source to be monitored using separate analog outputs.

- L Source:** Channel 1, Stereo C L/R input
- R Source:** Channel 2, Stereo C L/R input

Figure 4. Model 761 Digital Audio Inputs

276M standard. As expected, these signal sources will be provided in the form of coaxial cables with BNC plugs attached. The Model 761 supports sampling rates of up to 192 kHz with a word length (bit depth) of up to 24. Note that no external synchronization source is required as the inputs are all self-clocking.

Balanced AES3 digital audio signals can also be used with the Model 761's inputs so long as external coupling transformers ("baluns") are utilized. These impedance-matching (110 ohms to 75 ohms) transformer assemblies typically use a 3-pin female XLR connector on their input and a female BNC connector on their output.

Monitor Outputs

The connector labeled Analog Monitor Outputs provides access to the Model 761's 5.1 surround and 2-channel stereo director cue monitor outputs. The surround output channels are intended to connect to the main surround loudspeaker system incorporated in a facility. The director cue output channels are provided to support a separate set of loudspeakers, allowing monitoring of inter- or intra-facility communications.

The monitor output channels are intended for connection to audio amplifiers associated with monitor loudspeakers, or to the inputs of loudspeakers that contain integrated amplifiers. The monitor outputs are electronically balanced and capable of driving balanced or unbalanced loads of 600 ohms or greater. While balanced operation is preferred, unbalanced operation does not pose a problem. To connect to an unbalanced load connect the + terminal as signal high, and both the – and shield as the signal low/shield. For optimal unbalanced operation, it is important to connect

both – and shield together directly on the D-sub plug, not at the other end of the harness.

Note that while the Model 761's electronically balanced output circuits are capable of driving loads of 600 ohms or greater, the output level will drop slightly as the load impedance approaches 600 ohms. A 0.5 dB difference in output level can be expected as the load impedance changes from 10 k ohms to 600 ohms.

The wiring scheme used by the D-sub-miniature connector complies with that made popular by TASCAM® with their DA-88® product. A wiring assembly prepared for the Model 761's monitor outputs is identical to that of a DA-88-style output assembly. Please refer to Figure 5 for the exact connection details. Note that unlike a DA-88-style assembly, the Model 761's D-sub connector uses 4-40 threads. This complies with the original design standard for D-subminiature connectors.

| Connections | Signal High (+) | Signal Low (-) | Shield |
|----------------|-----------------|----------------|--------|
| L | 24 | 12 | 25 |
| R | 10 | 23 | 11 |
| C | 21 | 9 | 22 |
| LFE | 7 | 20 | 8 |
| LS | 18 | 6 | 19 |
| RS | 4 | 17 | 5 |
| Director Cue L | 15 | 3 | 16 |
| Director Cue R | 1 | 14 | 2 |

Notes: 1) Connector type on Model 761 is 25-pin D-subminiature female. Installer must provide plug (male). Connector uses 4-40 threaded inserts for locking with mating plug.

2) Wiring scheme follows TASCAM DA-88 convention. Standard DA-88-type wiring harnesses are directly compatible, with the exception of 4-40 screw threads being required.

Figure 5. Connections for Monitor and Director Cue Outputs

Metadata Input

The Model 761 allows a source of Dolby E metadata to be directly connected. Hardware and software inside the Model 761 extracts (“parses”) a dialnorm data element from the connected metadata signal. This dialnorm value can then be viewed on the Model 771 and, if desired, used to control the monitor output levels. Refer to the Technical Notes section of this guide for details.

The metadata must be in the form of an RS-485 or RS-422 asynchronous serial signal. This differential signal must have a data rate of 115.2 kbit/s and a data format of 8 data bits, no parity, and 1 stop bit (8-N-1). A metadata signal of this type is commonly available on metadata-generating or de-embedding equipment from broadcast equipment manufacturers such as Dolby Laboratories, Evertz, and NVISION.

While technically the Model 761’s RS-485 connection is bi-directional, in software it’s configured to only receive data. This means that there’s no reason why a signal already connected between two pieces of equipment can’t be connected in parallel (“bridged”) with the Model 761’s metadata input. Refer to Figure 6 for exact connection details. While only the data+ and data– connections are absolutely necessary, a shield connection can also be made. Note that the connections for the metadata signal are reminiscent of the SMPTE 207M standard.

Note that Studio Technologies has found documentation supplied with some metadata-generating equipment has incorrect pin-out information. This resulted in much head scratching and hair pulling. As such, it may be valuable to use a logic analyzer

| Signal | Pin | Direction |
|---------------------|-----|-----------|
| RS-485 Data+ | 7 | Input |
| RS-485 Data– | 2 | Input |
| Data Shield | 1 | Shield |
| Remote Mute All | 5 | Input |
| Remote Dim | 6 | Input |
| Remote Spare 1 | 8 | Input |
| Remote Spare 2 | 9 | Input |
| Remote Input Common | 4 | Common |

Note: Connector type on Model 761 is 9-pin D-subminiature female. Connector uses 4-40 threaded inserts for locking with mating plug.

Figure 6. Connector Pin Out for Metadata Input and Remote Control Inputs

or oscilloscope to confirm that the metadata source is terminated as expected prior to connecting it to the Model 761.

Remote Control Inputs

Support is provided for two remote control input functions: remote mute all and remote dim. The inputs use logic gates, “pulled up” to +5 V by way of resistors, which are active whenever they are brought to their logic low state. Inputs of this type are commonly referred to as GPI inputs. While the input circuitry is protected from over-current and static (ESD) discharge, care should be taken to prevent nasty signals from reaching them. The inputs are active only when held in the low state; they can’t be configured to change state (“latch”) in response to a logic pulse.

A 9-pin female D-subminiature connector is used to interface with the remote control inputs. This connector, labeled RS-485/Remote Control Inputs, is located on the back panel of the Model 761. Refer to Figure 6 for exact connection details. Note that pin 4 (remote input common) connects to the Model 761’s internal circuit com-

mon connection as well as the Model 761's chassis and mains earth connection. The two spare inputs are provided for future special applications. As such, pins 8 and 9 should remain unconnected.

Connecting the Model 761 to the Model 771

A 9-pin female D-subminiature connector, labeled To/From Control Console, is provided on the back panel of the Model 761 Central Controller. Another 9-pin D-sub connector, labeled To/From Central Controller, is provided on the back panel of the Model 771 Control Console. A cable with 9-pin male D-sub connectors on each end is used to interconnect the two units. A 20-foot (6.1-meter) cable is included in the shipping carton of each system. This cable implements all nine connector pins in a one-to-one manner.

Should an interconnecting cable of a different length be required there's no problem for one to be fabricated and used. While it can be wired in a one-to-one fashion covering all nine pins, a minimum of only four connections are required: data+, data-, DC+, and DC-. The Model 761's connector pin-out scheme was designed to allow creation of an interconnecting cable which uses commonly available two-pair audio cable. This cable, consisting of two twisted pairs each with an individual shield, is often sleek, flexible, and available in many colors. One pair and shield can be used for the data connections and the other pair and shield can be used for the DC connections. This implementation has the advantages of providing a shield for the data path and a more robust common connection (two conductors including the shield) for the DC power circuit. Refer to Figure 7 for details.

It's hard to specify a maximum interconnecting cable length. The data connections won't be the limiting factor as the differential transmission scheme of an RS-485 interface makes an interconnection in excess of 1000 feet (300+ meters) easily possible. The culprit is the DC current supplied by the Model 761 to power the Model 771. This nominal 12 volt DC, 100 milliamperes maximum signal is subject to the resistive voltage losses associated with the interconnecting cable. For correct Model 771 performance the voltage supplied to the Model 771, when measured directly at the Model 771's 9-pin connector and at full load, must be 9 volts minimum. This requires that the voltage drop due to the interconnecting cable be no more than 3 volts DC. Using Ohm's law, it's quite easy to determine whether the selected cable will support the desired interconnection length. To calculate the voltage drop, multiply the total resistance (in ohms) of the proposed cable by 0.01 (the square of the maximum current). Remember to include the resistance in both the DC- and DC+ wires.

| Signal | Pin | Direction |
|-----------------|-----|-------------------|
| Data+ | 1 | To/From Model 771 |
| Data- | 6 | To/From Model 771 |
| Data Shield | 2 | To/From Model 771 |
| DC+ | 4 | To Model 771 |
| DC- | 9 | To Model 771 |
| DC Power Shield | 5 | To/From Model 771 |

Note: Connector type on Model 761 is 9-pin D-subminiature female. Connector uses 4-40 threaded inserts for locking with mating plug.

Figure 7. Connections between Model 761 and Model 771

AC Mains Power

The Model 761 is internally configured to operate from nominal 100, 120, or 220/240 V, 50/60 Hz. Units shipped to North America are factory selected for 120 V operation. Units bound for Japan are generally selected for 100 V while our friends “down under” and in Europe receive units set for 220/240 V. Before connecting the Model 761 to AC mains power, check to be certain that it is configured to match the local mains voltage. Look on the back panel (adjacent to the power entry connector) for the factory-configured voltage. Note that an incorrect configuration could prevent operation or cause damage to the unit. Should it be necessary to change the unit’s operating voltage it must be performed only at the factory, or by a factory-authorized service technician.

The Model 761 uses an IEC-standard C14 connector to mate with the AC mains cord. The AC mains cord should have a C13 socket. The wire colors should conform to the internationally recognized CEE color code and be wired accordingly:

| <u>Connection</u> | <u>Wire Color</u> |
|----------------------|-------------------|
| Neutral (N) | Light Blue |
| Line (L) | Brown |
| Protective Earth (E) | Green/Yellow |

Safety Warning: The Model 761 does not contain an AC mains disconnect switch. As such, the AC mains cord plug serves as the disconnection device. Safety considerations require that the plug and associated outlet be easily accessible to allow rapid disconnection of AC mains power should it prove necessary.

As soon as AC mains power is applied, the Model 761 Central Controller’s power LED will light steadily. The two activity LEDs may also light. The Model 771 Control Console will go through a power-up sequence, lighting each LED in succession. Using its 4-digit display, the Model 771 will momentarily display both its, and the Model 761’s, software revisions.

Configuration

After the physical installation has been completed it's important that the system's configuration options be carefully reviewed. In most cases one or more of the operating parameters will need to be revised to meet the needs of a specific installation. Many of the parameters will impact the signal flow in to and out of the Model 761 Central Controller. Other parameters affect how the Model 771 Console will display status conditions and respond to user commands.

Configurable Parameters

Many StudioComm functions can be configured to meet the exact needs of an installation. The Model 771 Control Console is used to display and select the desired system configuration. Here's an overview of what can be configured:

- Digital Input Sample Rate
- Digital Input Reference Level
- Monitor Output Nominal Level
- SD Primary Input Type
- Director Cue Output Nominal Level
- Reference Level
- Overall Display Mode
- SPL Reference Level
- Dialnorm Reference Level
- Dim Level
- Remote Inputs

The configuration diagrams, located at the end of this section, give details on setting each parameter. An overview of each configurable parameter is provided in the following paragraphs.

Entering and Exiting the Configuration Mode

A small button is located on the back of the Model 771 Control Console, adjacent to the 9-pin D-sub connector. Pressing and holding this button for two seconds places both the Model 761 and the Model 771 into the configuration mode. The Model 761 will immediately mute the analog outputs as a protection measure. In the configuration mode the Model 771's array of buttons and LEDs no longer perform their normal functions, instead they allow you to observe and change many of the operating parameters. The dialnorm and output level LEDs, associated with the display mode section, will light alternately to indicate that the configuration mode is active.

To leave the configuration mode and return the Model 771 to normal operation once again press and hold the configure button for two seconds. Note that configuration changes are stored in nonvolatile memory only after the configuration mode has been exited.

Our apologies to those of you who find the configure button a pain to use, but it's supposed to be that way! Seriously, the top of the button is slightly recessed from the back panel, making it harder to accidentally activate. We didn't want normal operation to cease because someone pushed the Model 771 into a "rats nest" of schedules, magazines, or burrito wrappers! But a firm press with the fleshy part of an index finger should do the trick.

There is no problem frequently "tweaking" the Model 771's operating parameters to achieve the desired performance. The configuration data is stored in nonvolatile memory, which is rated for thousands of read and write cycles and a retention

time in tens of years. Note that the actual memory integrated circuit is located in the Model 761 Central Controller, rather than in the Model 771 Control Console.

Digital Input Sample Rate

The Model 761's digital audio inputs are compatible with signals that have sample rates spanning the professional digital audio range of 32 to 192 kHz. A configuration setting allows the performance of the digital audio receiver integrated circuits to be optimized for three sample rate zones within the overall range. The choices are 32 to 48 kHz, 88.2 to 96 kHz, and 176.4 to 192 kHz. Note that selecting the 88.2 to 96 kHz setting will also allow signals with a sample rate of 32 to 48 kHz to be received. But audio performance of those lower-rate signals may be compromised by clock rate confusion in the receiver circuitry. This situation also holds true for the 176.4 to 192 kHz setting which will allow signals with sample rates all the way down to 32 kHz to be received. But again the audio performance of the lower-rate signals could suffer from clocking errors. Note that the inputs are configured as a group; no individual receivers can be configured to a range different from the others. This is generally not an issue as a single sample rate is typically selected for each facility.

Digital Input Reference Level

Configuring the digital input reference level to match that of a specific installation is an important step toward achieving optimal audio performance. This ensures that the Model 761's digital audio receiver integrated circuits are set to match the digital input source's "0 VU" or average point. The digital input reference level can be selected from four choices: -20.0, -18.0,

-16.0, and -14.0 dBFS. SMPTE recommends a reference level of -20 dBFS, a value which is also extensively used in professional audio applications. The recommended digital reference level for PAL broadcast applications is -18 dBFS. The other two levels were included because... well, we can't remember why! But it seemed like a good idea at the time. If you end up using the -16.0 or -14.0 dBFS levels please let us know why.

Monitor Output Nominal Level

The nominal level of the six monitor output channels can be configured, as a group, to match the requirements of an installation. This setting defines the analog output level when a digital input source, at its reference level, is connected and the monitor output level control is at its maximum. The choices are 0.0 dBu and +4.0 dBu. Most applications will find the +4.0 dBu setting correct as it meets the dominant worldwide audio standards. For broadcast applications that follow the PAL standards the 0.0 dBu setting may be appropriate.

While sometimes not fully understood, using the term dBu is more in line with contemporary audio applications than the outdated dBm and the "semi-pro" dBV references; dBu refers to audio levels without regard to their load impedance, typical of situations where an output has a low source impedance and is connected to a high-impedance input. An analog audio signal with a level of +4 dBu has an RMS level of 1.228 volts. A 0 dBu signal will have an RMS level of 0.775 volts.

A final review of the selected setting might now be in order. The most common input and output combination will have a digital input reference level of -20 dBFS and a monitor output nominal level of +4 dBu.

For PAL broadcast applications a setting of -18 dBFS for the digital input and 0 dBu for the analog outputs would be typical.

SD Primary Input Type

The type of source connected to the digital audio input connectors associated with the SD primary input selection can be configured. The choices are 5.1 surround or 2-channel stereo. When selected for 5.1 surround six input channels are associated with SD primary: L, R, C, LFE, LS, and RS. Selecting 5.1 surround as the input type also allows the 5.1 to stereo downmix function to be enabled. When the input type is selected for 2-channel stereo only the L and R channels are active for SD primary; C, LFE, LS, and RS are disabled. In addition, the 5.1 to stereo downmix function is disabled.

Director Cue Output Nominal Level

The nominal level of the director cue output can be configured from four available settings: $+4.0$ dBu, 0.0 dBu, -6 dBu, and -12.0 dBu. This range of settings is provided so that compatibility can be achieved with a variety of connected devices. The $+4.0$ dBu and 0.0 dBu settings are appropriate for device inputs that expect to receive full line-level signals. Devices such as amplified speakers will often perform better when receiving signals with a lower nominal level. In the latter case the ability to comfortably use a level potentiometer may be greatly enhanced using the -6.0 dBu or, especially, the -12.0 dBu setting.

Reference Level

For audio-with-picture applications it's often beneficial for monitoring to be done in reference to a known loudspeaker level. This is often referred to as "mixing to 85 dB" on the monitors. The StudioComm

system allows a precise monitor output level to be stored, and then enabled by pressing the Model 771 button labeled Reference Level. Setting the reference level is very simple but care is required:

1. Set up a precision sound pressure level (SPL) measuring device at the desired listening location.
2. Place the StudioComm system in the normal operating mode, not the configuration mode. Be certain that the dim, mute all, reference, dialnorm enable, and downmix functions are not active. The remote mute or remote dim functions must also not be active.
3. Use the Model 771 Control Console to select the input source that contains the desired reference signal source, e.g., pink noise.
4. Observing the SPL meter, adjust the Model 771's rotary level control until the desired reference monitor system level has been reached.
5. Being careful not to disturb the position of the rotary level control, enter the configuration mode by pressing and holding the configuration button located on the Model 771's back panel.
6. Once the configuration mode has been entered, the monitor outputs will mute. Press and hold the reference button; the associated LED will begin to flash. After five seconds the LED will light solidly to indicate that a "snapshot" of the new reference level has been taken. The level display will then show the value of the new reference level. The value shown will always be a negative number as it's always a value less than the maximum output level. The reference button can now be released.

7. To complete the process the configuration mode must be exited. This is performed by again pressing and holding the configure button for two seconds. The new reference level is now stored in the Model 761's nonvolatile memory. Only by repeating the entire procedure can the value be changed.

Once the configuration mode has been exited, the monitor outputs will again become active. Confirm that the correct level has been stored by pressing the reference button. The SPL meter should display the desired level. If not, repeat the calibration procedure to achieve the goal.

You might wonder why you have to press and hold the reference button for five seconds before the selected value is recognized. This is provided specifically so that unauthorized users won't accidentally change the reference level while they experiment with the configuration mode. Only if you know the "secret" will you be able to store a new value.

Overall Display Mode

The Model 771's 4-digit numeric display can be configured to display the output level in either an attenuation mode or an SPL mode. In the attenuation mode the output level is shown as a reduction in value relative to the maximum output level. When the rotary level control is at its fully clockwise position the maximum output level is obtained and the display will show 0.0. As the rotary control moves in the counterclockwise direction the display will show negative values, reaching approximately -69.5 dB before the full mute function automatically mutes the outputs.

In the SPL mode the display can be configured to allow the output level to be presented to a user in terms of the actual sound pressure level (SPL). Used in conjunction with the SPL reference level configuration and the stored configuration level, SPL mode allows a user to see a visual representation of the SPL level that is present in the listening environment. While correct implementation of the SPL display mode takes a little more care, it can offer an enhanced experience for StudioComm users.

SPL Reference Level

The SPL reference level configuration allows a specific SPL number to be associated with the stored reference level value. In this way whenever the monitor output is at the stored reference level, either through activating the reference level function or manually adjusting the rotary level control, the Model 771's display will show the configured SPL level. Whenever the monitor output is not at the reference value the display will show the current value, in dB, relative to the reference level. The SPL reference level can be configured over a range of 70.0 to 100.0 dB in one-dB steps. In many applications a value of 85 would be appropriate, reflecting the widely used audio-for-picture 85 dB monitoring reference level. (Typically this 85 dB is really 85 dBC, indicating that a C-weighting filter has been applied to the measurement.) Other common reference SPL values, such as 82 and 87, are well within the allowable range.

Dialnorm Reference Level

The dialnorm reference level parameter is provided so that the StudioComm system can be configured to match a facilities' or

“plant” default dialnorm level. This value is used as a reference against which the surround monitor output level will, if enabled, be adjusted up or down in response to an incoming dialnorm value. The dialnorm reference level parameter can be adjusted over the entire -31 to -1 dB range but typical values will be in the range of -27 to -24 . Implementation purists might want to select -31 dB as it may well be the “truest” implementation of the dialnorm scheme. In this way the system will, when enabled, reduce the monitor output level whenever dialnorm is different than -31 dB. But as bar fights have broken out over decisions such as this we’ll leave the choice up to you! For additional information about dialnorm refer to the Technical Notes section of this user guide.

Dim Level

The dim function is used to reduce the monitor output level by a preset amount. The reduction is in dB relative to the monitor output’s current level. There are four dim level values available: -10.0 , -15.0 , -20.0 , and -25.0 dB.

Remote Mute All

Two configuration choices are associated with the remote mute all function: disabled and enabled. To utilize the remote mute all function simply requires you to select the enabled setting.

Remote Dim

Two configuration choices are associated with the remote dim function: disabled and enabled. To utilize the remote dim function simply configure it for enabled.

Restore Factory Defaults

The restore factory defaults function is provided primarily for factory use. In this way a system can be shipped with the default settings selected. While you are welcome to use this function, be careful that your configuration efforts aren’t wasted. Specifically, be aware that the reference level is reset to minimum level. All the other parameters are fairly easy to set up, but resetting the reference level would require getting out an SPL meter and connecting a calibrated signal source. This is a hassle you may not need!

Model 771 Configuration—Entering and Exiting Configuration Mode

 Press and hold the configuration button for 2 seconds to enter or exit the configuration mode.

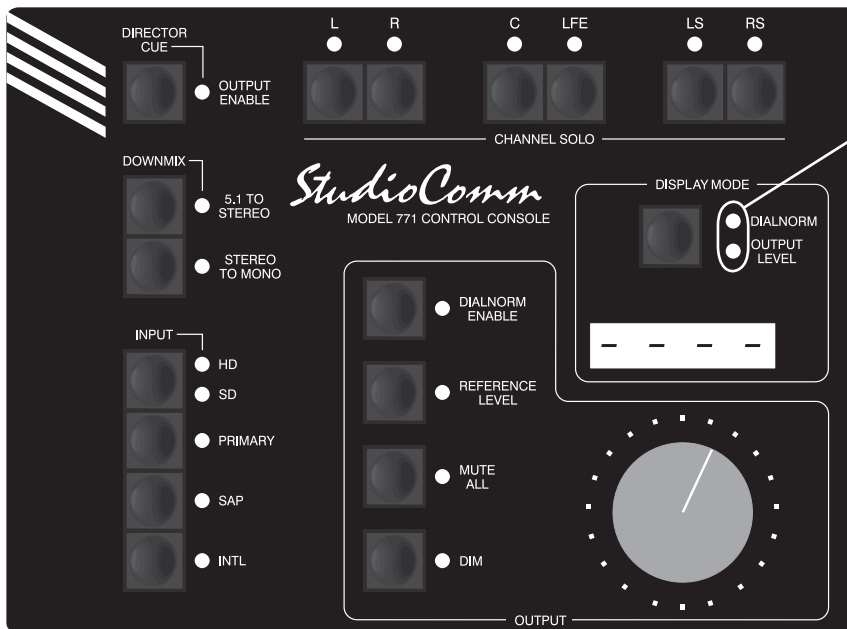
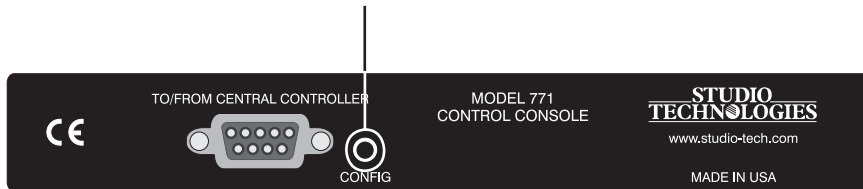

These LEDs will light alternately when configuration mode is active.

Model 771 Configuration—Digital Input Sample Rate, Digital Input Reference Level, and Monitor Output Nominal Level

When the Mute All button is pressed, the 4-digit display shows the currently selected digital input reference level. Use the 5.1 to Stereo button to increase the reference level. Use the Stereo to Mono button to decrease the reference level. Available digital input reference levels are -20.0 dBFS, -18.0 dBFS, -16.0 dBFS, and -14.0 dBFS.

When the Mute All button is pressed, use the Channel Solo L and R buttons to select the monitor output nominal level. Use the buttons to change the configuration. LED L lit means nominal level is 0.0 dBu; LED R lit means nominal level is $+4.0$ dBu.

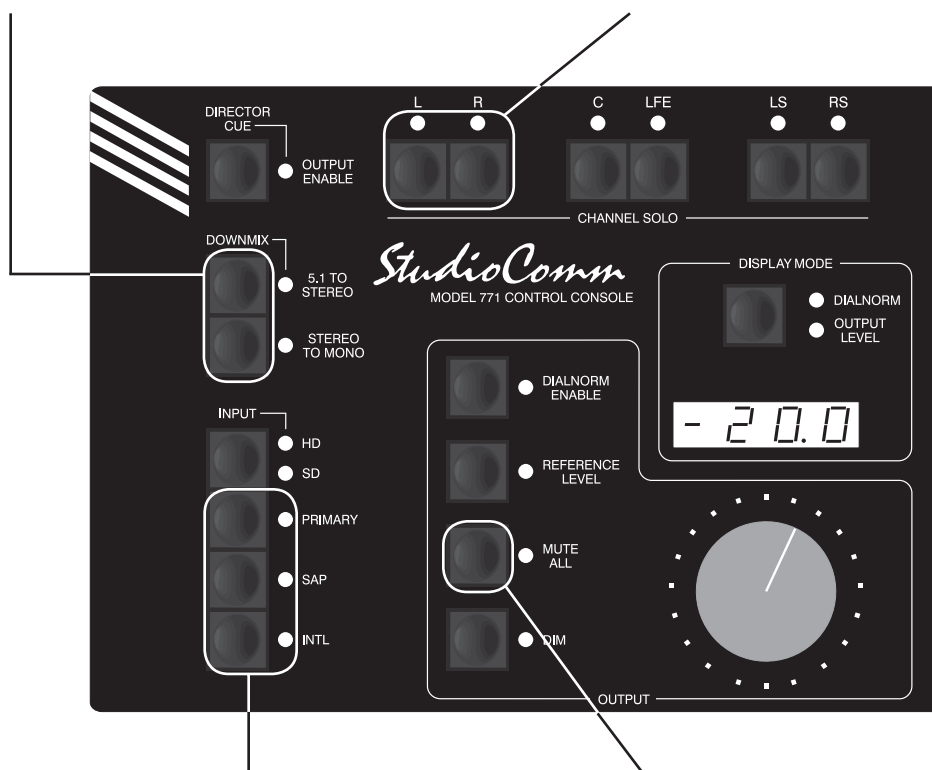

When the Mute All button is pressed, use these buttons to select the digital input sample rate. INTL lit means 32 to 48 kHz; SAP lit means 88.2 to 96 kHz; Primary lit means 176.4 to 192 kHz.

 Press and hold the Mute All button to display and select the digital input sample rate, digital input reference level, and monitor output nominal levels.

Default: 32 to 48 kHz digital input sample rate.
 -20.0 dBFS digital input reference level.
 $+4.0$ dBu monitor output nominal level.

Model 771 Configuration—SD Primary Input Type

Use the 5.1 to Stereo and Stereo to Mono buttons to set the SD primary input type. 5.1 to Stereo LED lit means SD primary is 5.1; Stereo to Mono LED lit means SD primary is stereo.

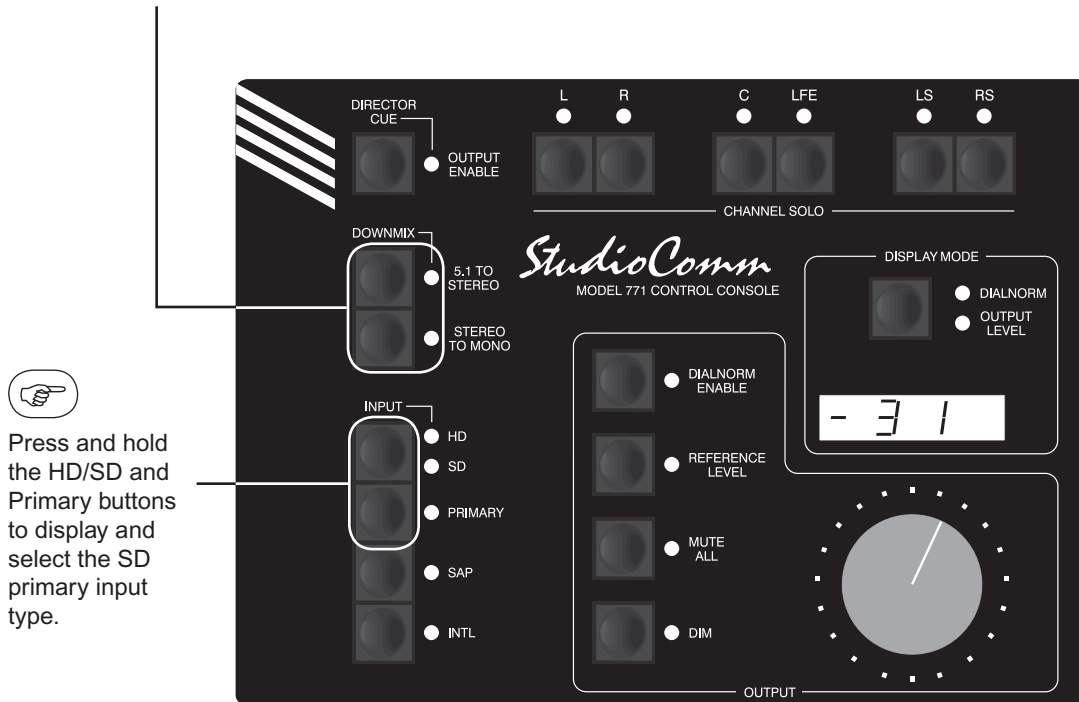

Press and hold the HD/SD and Primary buttons to display and select the SD primary input type.

Default: Stereo SD primary input type.

Model 771 Configuration—Director Cue Output Nominal Level

 Press and hold the Director Cue Output Enable button to display and select the director cue output nominal level.

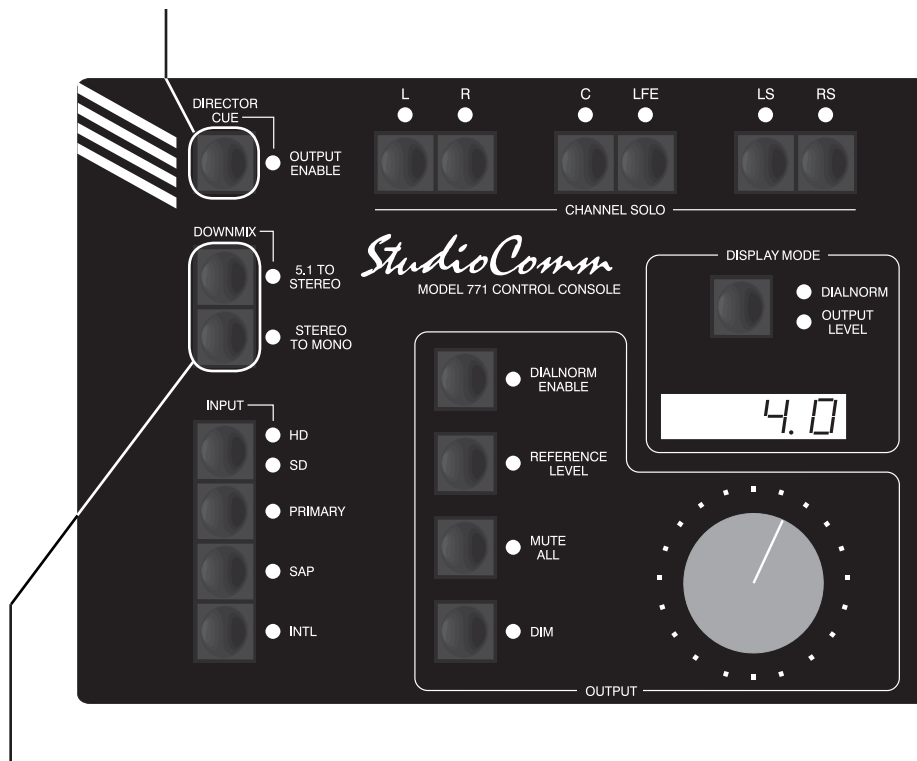

When the Director Cue Output Enable button is pressed, the 4-digit display shows the selected director cue output nominal level. Use the 5.1 to Stereo button to increase the nominal level. Use the Stereo to Mono button to decrease the nominal level. Available director cue output nominal levels are: +4.0 dBu, 0.0 dBu, -6.0 dBu, and -12.0 dBu.

Default: +4.0 dBu director cue output nominal level.

Model 771 Configuration—Reference Level

 Press and hold the Reference Level button for 5 seconds to take a “snapshot” of the level control’s setting at the time configuration mode was entered. The Reference Level LED will flash when the button is initially pressed and then light solid when the “snapshot” has been taken.

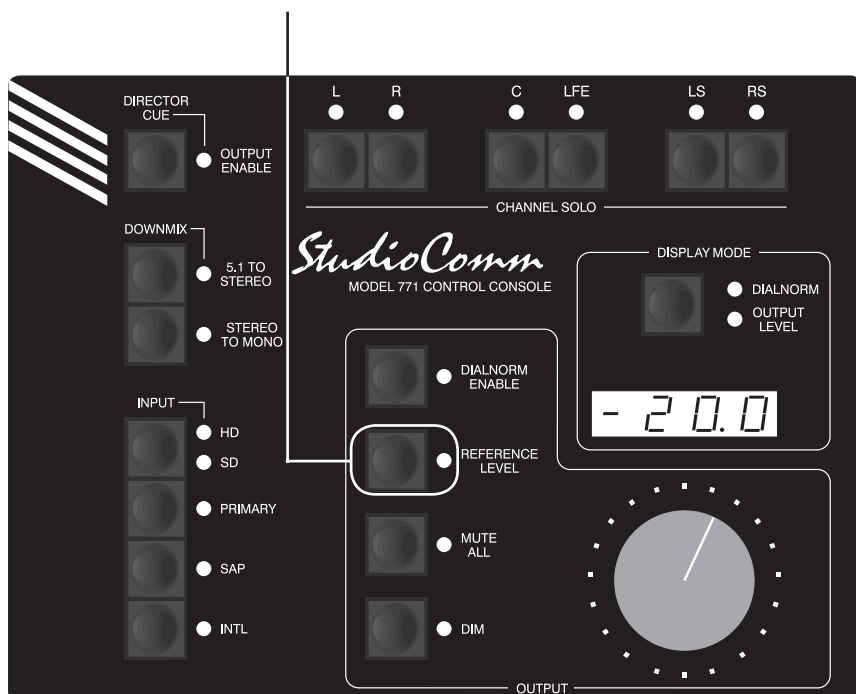

Default: Reference level set for fully attenuated (minimum) monitor output level.

Note: The 5-second delay is a safety feature ensuring that the reference level will not be accidentally changed. To permanently store the new value, you must still exit the configuration mode.

Model 771 Configuration—Overall Display Mode and Reference Level in dB SPL

When the Display Mode button is pressed, use the Channel Solo L and R buttons to select the overall display mode. LED L lit means attenuation mode is selected; LED R lit means SPL mode is selected. Use the buttons to change the configuration.

When the Display Mode button is pressed, use the 5.1 to Stereo button to increase the reference level in dB SPL. Use the Stereo to Mono button to decrease the reference level. The range is 70.0 to 100.0 dB in one-dB steps.





Press and hold the Display Mode button to display and set the overall display mode and the SPL reference level.

Default: Attenuation display mode selected.
85.0 dB SPL reference level.

Model 771 Configuration—Dialnorm Reference Level

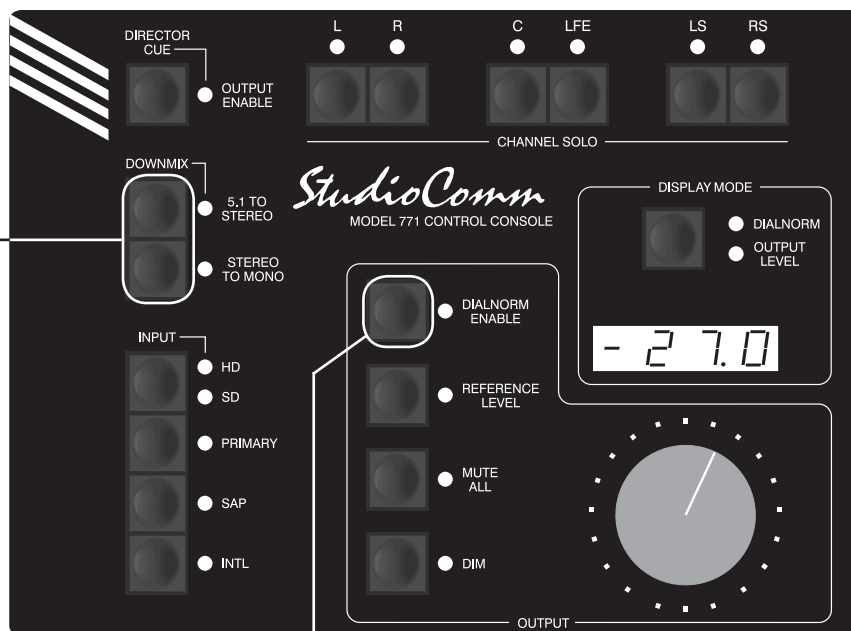
When the Dialnorm Enable button is pressed, use the 5.1 to Stereo button to increase the dialnorm reference level. Use the Stereo to Mono button to decrease the dialnorm reference level. The range is -31 to -1 dB in one-dB steps.



 Press and hold the Dialnorm Enable button to display and set the dialnorm reference level.

Default: -31 dB dialnorm reference level.

Model 771 Configuration—Dim Level, Remote Mute All, and Remote Dim

This LED displays the configuration of remote mute all. LED not lit means remote mute all is disabled; LED lit means enabled. Use the button to change the configuration.

This LED displays the configuration of remote dim. LED not lit means remote dim is disabled; LED lit means enabled. Use the button to change the configuration.

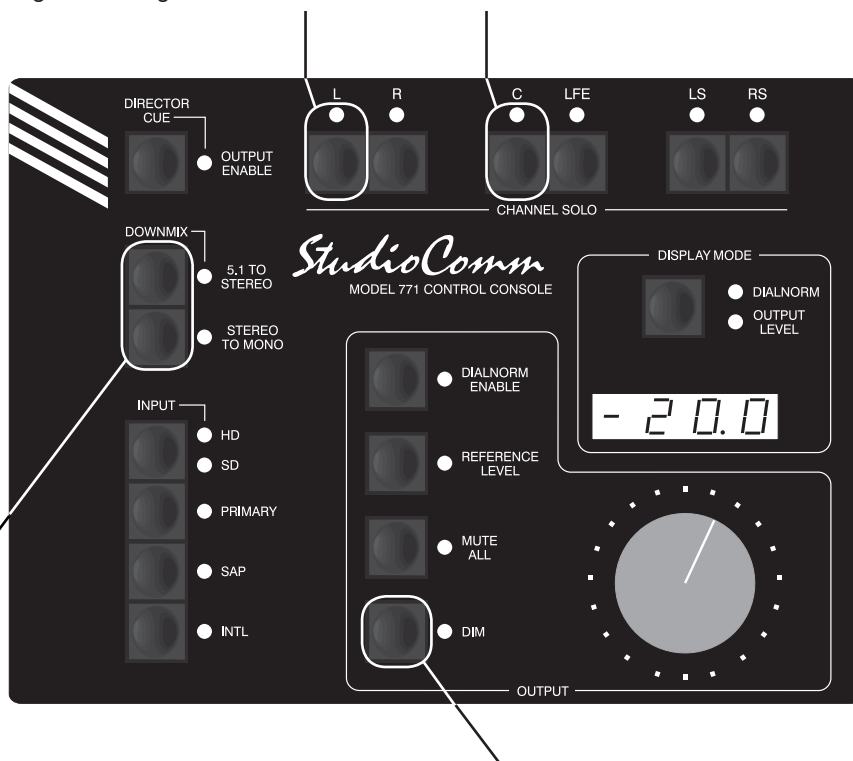

When the Dim button is pressed, the 4-digit display shows the currently selected dim level. Use the 5.1 to Stereo button to decrease the dim level. Use the Stereo to Mono button to increase the dim level. Available dim levels are -10.0 dB, -15.0 dB, -20.0 dB, and -25.0 dB.



Press and hold the Dim button to display and select the dim level, remote mute all, and remote dim input configurations.

Default: -20.0 dB dim level.
Remote mute all disabled.
Remote dim disabled.

Model 771 Configuration—Restore Factory Defaults



Press and hold both the Dialnorm Enable and Dim buttons for 5 seconds to restore Model 771 factory defaults. Once defaults have been restored, the associated LEDs will light. After the buttons are released, configuration mode will be exited and normal operation will resume.

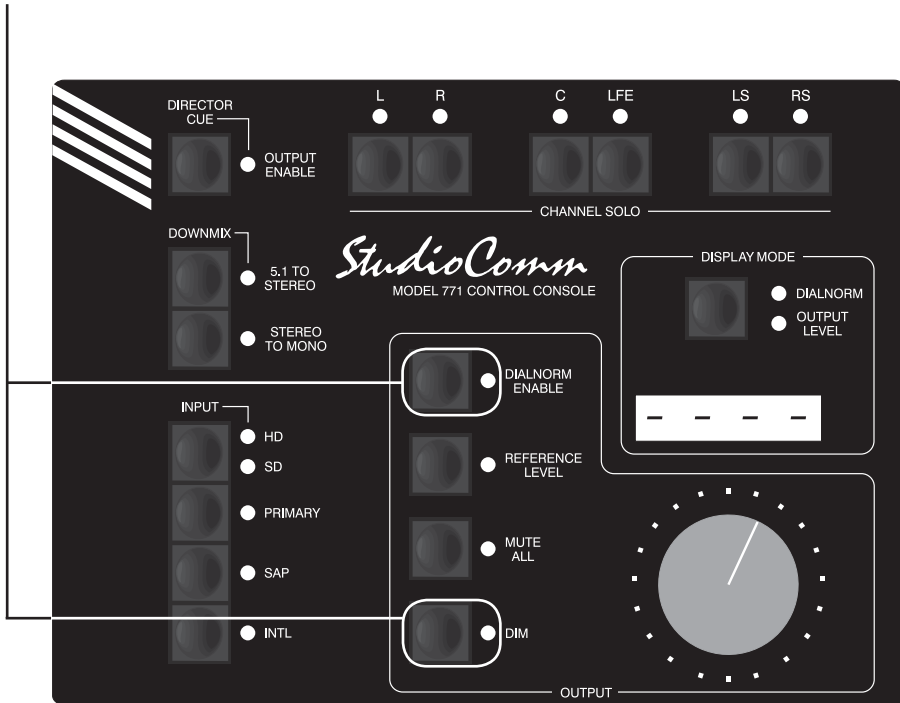

Factory Defaults: 32 to 48 kHz digital input sample rate.
–20.0 dBFS digital input reference level.
+4.0 dBu monitor output nominal level.
Stereo SD primary input type.
+4.0 dBu director cue output nominal level.
Reference level set for fully attenuated (minimum) monitor output level.
Attenuation display mode selected.
85.0 dB SPL reference level.
–31 dB dialnorm reference level.
–20.0 dB dim level.
Remote mute all disabled.
Remote dim disabled.

Note: The 5-second delay is a safety feature ensuring that the factory defaults will not be accidentally restored.

Operation

Now that you've installed and configured the system, you're ready to go. You should find operation very easy. However, taking time to study this section of the guide may prove valuable, especially regarding the system's support for dialnorm.

Model 761 Central Controller

The Model 761's front panel contains three LEDs. The power LED should be lit whenever AC mains power is connected. The control console activity LED will light steadily whenever the Model 761 is communicating correctly with the Model 771. This LED will remain off during the system power-up process, something that typically takes several seconds to complete. The metadata activity LED will light whenever an active metadata signal has been connected and valid sync word information is being received.

Model 771 Control Console

StudioComm operation is controlled using the Model 771 Control Console and, if connected, the remote control inputs. To make things easy to describe, we've divided the StudioComm functions into seven main groups: input source selection, downmix, monitor output general functions, channel solo, director cue output, display and display mode, and remote control inputs.

Input Source Selection

Four input select buttons work together to allow monitoring of up to six input sources. One source can be selected for monitoring at any one time. The input sources are grouped into two sets of three with the groups labeled SD and HD. Each group's three input sources are labeled primary,

SAP, and international (INTL). The titles were selected to match the names commonly assigned to sources in broadcast facilities. The SD (standard definition) primary input supports either a 5.1 surround or 2-channel stereo source. The HD (high definition) primary input supports a 5.1 surround source. The SD and HD SAP and international inputs each support a single-channel monaural source. SAP is a broadcast-derived acronym for secondary audio program. An "international" source simply refers to an alternate source that is typically associated with remotely originated broadcast material. Note that, as would be expected, the titles of the actual sources connected to a specific StudioComm system may not match the Model 771's descriptions. Local technical personnel should be familiar with the actual connected sources.

The SD/HD button is used to select the active group. Pressing the button will alternate between the groups. Two LEDs are associated with the SD/HD button and indicate which of the groups is active. Three buttons are used to select the specific input source to be monitored. They are labeled primary, SAP, and INTL (international). LEDs are associated with these buttons and indicate which is active. Note that the Model 771 "remembers" which specific input was last selected for each group, so changing between groups will switch between two specific inputs. This allows rapid switching between, as an example, SD primary and HD SAP.

Downmix

Two downmix functions allow users to perform "real-world" audio format compatibility checks. One function allows a 5.1 surround signal to be "folded down" (converted) to

stereo. The other allows a stereo signal to be converted to mono. Using the downmix functions simply requires pressing the designated buttons. The buttons are set to “latch” the functions on and off. An LED is located adjacent to each button and lights whenever its respective function is active.

When the 5.1 to stereo downmix function is enabled the LS and RS channel’s associated with a 5.1 surround signal is combined (“folded down”) with the L and R signals to create a 2-channel stereo (left and right) signal. The resulting stereo signal is routed to the left and right monitor output channels. The LS, RS, and LFE monitor output channels are muted. By utilizing this downmix function phase relationships and inter-channel level issues can be quickly observed.

The stereo to monaural downmix function combines the left and right audio channels to create a single-channel monaural signal. This signal is sent to the center channel monitor output. The L, R, LS, RS, and LFE channels are muted. Please refer to the Technical Notes section of the guide for a detailed description on how the downmix functions perform their tasks.

Note that when a 5.1 surround source is selected as the input source, the 5.1 to stereo downmix function will automatically enable whenever the stereo to mono downmix function is enabled. This ensures that an operator will hear a mono signal created by folding down all channels associated with the selected input.

The Model 771 associates the state of the downmix functions with the currently selected input. For example, if HD primary is the selected input source and 5.1 to stereo downmix is enabled, that condition will be “remembered” when switching to

another input source. Upon returning to HD primary as the input source, the 5.1 to stereo downmix function will again become active.

Note that a specific downmix function can only be enabled when it is applicable for the currently selected input source. This means that the 5.1 to stereo downmix function can only be enabled when a 5.1 surround input source is selected. Neither of the downmix functions can be enabled when one of the SAP or international input sources is selected. This is because these inputs are already monaural and wouldn’t be subject to any additional fold down.

Monitor Output General Functions

Four buttons and one rotary control are associated with the monitor output functions. The buttons control operation of the dim, mute all, reference level, and dialnorm enable functions. The rotary level control is used to manually set the monitor output level.

Dim

The dim function is provided for user convenience, allowing the monitor output level to be reduced by a fixed amount. The Model 771’s configuration mode allows the dim level to be selected from among four choices: –10, –15, –20, or –25 dB. Pressing the dim button will enable the function. The dim button is always set to “latch” the function on and off. The 4-digit display, when selected for output level mode, will indicate the revised monitor output level. If the “dimmed” output level is equal to or less than the minimum attenuated level, the monitor output will go into a full mute and the display will show four horizontal dashes. When dim is active the monitor

output level reduction will apply no matter whether the monitor output level is being set by the rotary level control or by the reference level button. The LED associated with the dim button will light whenever dim is active. If dim mode is enabled via the remote dim function the dim LED will flash.

It's worth a using a few sentences to discuss the auto dim off function. Whenever dim is enabled due to the dim button being pressed, as well as the rotary level control being active (reference level mode is not active), changing the setting of the rotary level control will automatically turn off dim. The auto dim off function is a unique attempt at protecting the aural health of users. No longer will there be a heart-stopping blast of audio when the dim button is pressed, supposedly to enable dim, but actually turning dim off because it was already enabled. It's hard to explain unless you've experienced this in person—trust us, this situation can and does happen!

Note that the auto dim off function is not active whenever dim is enabled due to the remote dim function being active. This allows remote control equipment, such as a talkback system, to reliably dim the monitor outputs.

Mute All

The mute all function is highly complicated to operate—not! Pressing the mute all button causes all six monitor output channels to mute. The 4-digit display indicates the mute condition by showing four horizontal dashes. The mute all button is always set to “latch” the function on and off. The LED associated with mute all will light whenever mute all is active. Note that if mute all is enabled via the remote mute all function, the mute all LED will flash.

Reference Level

The reference level button sets the monitor output level to a preset value. Technical personnel, using a sound-pressure-level (SPL) meter and precision signal source, should have set this level to meet the requirements of the exact monitoring environment. The LED associated with the reference level button lights whenever the function is active. Whenever the reference level mode is active the rotary level control is disabled. The 4-digit display will indicate the reference output level. Note that the system's default reference level is full mute so “out of the box” the 771 will display four horizontal lines when reference level mode is enabled.

The reference level LED also serves as a calibration aid. If the reference level mode is not active, whenever the monitor output level is precisely the same as that stored for the reference value the reference LED will flash. The monitor output level can reach this exact level through the use of the rotary level control by itself or through the setting of the rotary level control in conjunction with the dialnorm data and dim function. Whatever path the output level takes to reach the reference level value, it will cause the reference level LED to flash!

Dialnorm Enable

Enabling the dialnorm level function simply requires pressing the dialnorm enable button. The button provides a “latching” function so that the selected state is maintained. An associated LED will light whenever the function is active. The dialnorm enable function is only active when the input source is selected for HD primary. (This is because dialnorm level data is available only for that specific source.)

When enabled, and HD primary is the input source, as the dialnorm level changes the output level will automatically increase or decrease as is appropriate. During configuration of the system a dialnorm reference level was entered. This level, typically in the range of -27 to -24 dB, is compared to the incoming dialnorm level value. If the received dialnorm level is less than the reference value the output level is increased by the difference. If the received dialnorm level is greater than the reference value the output level is decreased, again by the difference. Note that dialnorm levels are limited to a range of -31 to -1 dB. This restricts the maximum amount of level control to 30 dB.

The 4-digit display, when selected for output level mode, will display all level changes as they occur, including level changes due to dialnorm activity. The received dialnorm level values can themselves be viewed by selecting the display dialnorm mode.

In either display mode the decimal point “dot” in the lower-right corner of the display will light whenever the input dialnorm value matches the dialnorm reference value. This topic is described in greater detail in the Display and Display Mode section of this section of this guide. The Technical Notes section of this guide also will provide additional useful information about dialnorm.

Rotary Level Control

The rotary level control is used to manually adjust the monitor output level. It is active whenever the reference level function is not active. The level control provides the ability to adjust the monitor output level over an approximately 70 dB range. The reference LED will flash when the rotary level control sets the output level to be the same as the stored reference level. Whenever the rotary

level control is set to its fully counterclockwise position, the monitor output channels automatically mute. Technically, this has the same effect as when the mute all function is active.

Channel Solo

The channel solo function allows specific channels to be selected for individual or group “solo” monitoring. The function takes place electrically “after” the input source selection, downmix, and level control functions. A channel selected for solo actually doesn’t change, but the solo function causes the non-soloed monitor output channels to mute. This leaves only the soloed output active. Six buttons and six LED indicators are associated with the channel solo function. To solo a channel simply requires pressing one of the solo buttons. The buttons function in a press-to-enable/press-to-disable “latching” mode. The LED associated with a soloed channel will flash to indicate that solo is active. More than one output channel can be selected for soloing at a time. The Model 771 even allows all six monitor output channels to be simultaneously selected for solo. This seems like an “all soloed so none soloed” mode but this condition is specifically allowed so that an output channel mute function can be provided. By first soloing all output channels an operator can then “un-solo” specific channels, directly muting them. It’s a bit confusing to describe in words but is very simple to use and can be very useful resource—try it out and you’ll see!

Director Cue

Controlling the on/off state of the director cue output is simply a matter of pressing the director cue button. It functions in an

alternate action manner to change the current state of the output. An associated LED lights whenever the director cue output is active. The director cue output is not impacted, nor does it impact any of the other Model 771 functions.

Display and Display Mode

The 4-digit LED display can be selected to show either the output level or the dialnorm level. The display mode button is used to select the desired mode. Two LEDs are associated with the button, indicating which mode is active. When selected for the output level display mode, what the digits actually show will depend on how the Model 771 is configured. If configured for the attenuation mode the display will show the output level as an attenuation value in reference to the maximum output. For example, when the rotary level control is set to its fully clockwise position the displays will typically show 0.0. This indicates that no attenuation is taking place in the signal path. (The signal path starts with the selected input source and ends with the monitor outputs.) As the rotary level control is moved counterclockwise readings such as -20.0 or -35.0 would be typical.

If the Model 771 is configured to display the output level in SPL, the 4-digit display will always show the output level in positive numbers. These numbers are intended to represent the sound pressure level in dB SPL, a figure that should directly relate to the actual sound pressure level that the loudspeaker system is presenting to users. (Typically, the level value would actually be in dBC, the C-weighted sound pressure level.) When the reference level button is enabled, or the rotary level control is set so that the reference level has been reached, the display will typically show something in

the range of 82 to 87. Assuming that the monitoring environment has been correctly calibrated, this would indicate that an average listening level of 85 dB SPL, for example, had been achieved.

When the 4-digit display is set for the dialnorm display mode a much different piece of information will be shown to the user. It will show the somewhat obscure but important dialnorm level parameter that's associated with the HD primary input source. As has been covered in other parts of this guide, dialnorm is intended to provide a numeric value that represents the average dialog level associated with an audio-for-picture element. Technically, dialnorm values can range from -31 to -1 dB but during actual operation they will typically be in the range of -30 to -20 dB. The value may change frequently in conjunction with changes to the actual audio signal. In other situations the dialnorm level will only change when certain sources, such as a live 5.1 surround event, are being "aired." On the extreme end, in some facilities the dialnorm level is fixed and won't ever change. That's not really in the spirit of what dialnorm is supposed to accomplish, but *c'est la vie*. Whatever the dialnorm level—the Model 771 will display it!

In both display modes a special feature is provided to assist users in knowing if the current dialnorm level matches a facility's "house" reference. This reference level, typically in the range of -24 to -27 dB, is entered as part of the Model 771's configuration process. The "dot" in the lower-right corner of the 4-digit display will light whenever the incoming dialnorm level matches the stored reference level. Refer to Figure 8. This feature can be useful in broadcast transmission and distribution applications. In theory, any time the

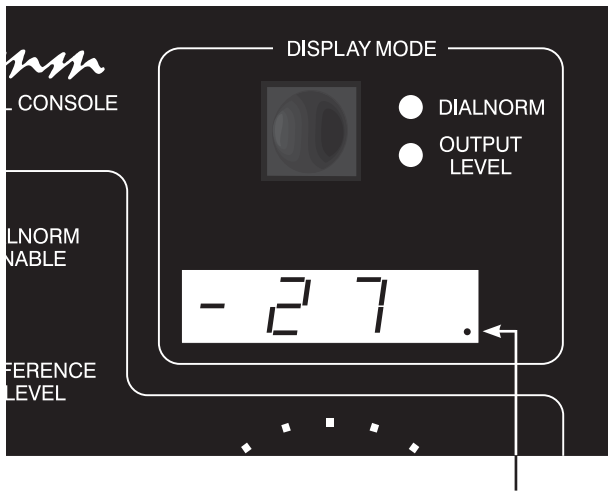

Figure 8. Incoming dialnorm level match “dot”

dot in the lower-right corner is not lit the current dialnorm level value is causing a level adjustment to take place. This level adjustment can be taking place in the StudioComm system, if the dialnorm enable function is active, as well as in downstream users of the broadcast signal.

Note that if a valid dialnorm source is not available the 4-digit display, when selected to display dialnorm, will show four horizontal bars. This could be due to a problem with the metadata signal connected to the Model 761 Central Controller. But more frequently this will simply be the normal result that occurs when the Model 771's input is not selected for HD primary.

Remote Control Inputs

Two remote control signals can be connected to the StudioComm system and configured for operation. The two functions are remote mute all and remote dim. When an external signal activates remote mute all the LED on the Model 771 associated with mute all will flash. If mute all was already active when the remote mute all function is activated, the LED will change from being steadily lit to flashing.

When an external signal activates remote dim the LED on the Model 771 associated with the dim function will flash. If dim was already active when remote dim is activated, the LED will change from being steadily lit to flashing.

Technical Notes

Dialnorm

A source of Dolby E metadata can be connected to the Model 761 Central Controller. Within this flow of metadata frames will be a “dialnorm” level value that’s associated with the 5.1 surround signal that serves as the Model 761’s HD primary input. The dialnorm level value can be displayed by the Model 771 Control Console and used to control the monitor output level.

Technically, the metadata is in the form of a 115.2 kbit/s RS-485/RS-422 signal that contains a number of data elements, including one or more that represent the average dialog level (dialog normalization or dialnorm) in the audio program signals being carried over the digital audio portion of the related Dolby E interface. These dialnorm levels are associated with specific programs within the 8-channel audio “stream.” Firmware within the Model 761 is able to parse (separate) the data elements, specifically separating the first dialnorm level value in the metadata frame from the one or more that may be present later. To clarify, any dialnorm level elements that occur later in the same metadata frame are ignored. This method was selected as it was assumed that the first dialnorm level element will always be associated with a 5.1 program. There’s a technical basis for why this should be true. In Dolby E a 5.1 program is always assigned to the first six channels (channels 1-6). While there may be separate dialnorm values associated with audio channels 7 and 8, they are not relevant for correct StudioComm system operation.

Downmix

The downmix functions are implemented in the Model 761 Central Controller’s hardware using analog circuitry. The 5.1 to stereo downmix function performs this action: center (C) dropped in level by 6 dB and routed to left (L) and right (R) monitor outputs; left surround (LS) dropped in level by 3 dB and routed to L monitor output; right surround (RS) dropped in level by 3 dB and routed to R monitor output; low-frequency-enhancement (LFE) input muted. The stereo to mono downmix function performs this action: L dropped in level by 3 dB and routed to the C monitor output; R dropped in level by 3 dB and routed to the C monitor output; C, LS, RS, and LFE inputs mute.

“Hot” Disconnection of the Model 771 Control Console

There’s no problem relocating the Model 771 Control Console while your StudioComm system is operating. You can disconnect the 9-pin interconnecting cable, move the unit, and then re-connect without issue. Upon disconnection the Model 761 Central Controller will mute the monitor output channels as well as saving the current operating parameters. No clicks, pops, or other noises will occur when the Model 771 is again connected. The Model 771 will go through its standard power-up sequence and then normal operation will resume.

Monitor Output Transient Protection

The Model 761 Central Controller contains a power-up/power-down transient protection feature. This limits the chance of

damage to the monitor loudspeakers during the time when AC mains voltage is connected, disconnected, or has changed significantly from nominal. A combination of hardware and software is used to monitor one of the power supply “rails.” Until the AC mains input exceeds its nominal operating voltage range, electromechanical relays maintain a short-circuit condition on the monitor outputs. After the input voltage is recognized as valid, a short delay takes place before the relays are allowed to function normally. Whenever the AC mains input drops below its nominal operating voltage range, the relays immediately go to their mute state. During testing it was found that upon power up the monitor outputs remained very quiet; during power down a small to moderate “tick” was the worst that was heard.

Model 761 to Model 771 Connections

Figure 7 gives a detailed description of the signals that connect the Model 761 Central Controller to the Model 771 Control Console. The Model 761 provides a +12 volt DC power source for use by the Model 771’s circuitry. The DC output is current-limited to minimize the chance that a short-circuit condition will damage the Model 761’s circuitry. An asynchronous, bi-directional, data interface links the two units. The RS-485 hardware connection scheme operates at a rate of 115.2 kbit/s and uses an 8-N-1 data format. The Model 761 communicates with the Model 771 20 times per second, receiving button and rotary level control information and sending LED and 4-digit display status data.

Mono-to-Center Polarity

It’s worthwhile to note that a polarity inversion takes place whenever the stereo to mono downmix function is active. By design, the left (L) and right (R) input signals experience a 180-degree inversion in the Model 761’s combining circuitry. This should not cause a problem as monitoring audio signals over a single loudspeaker is considered polarity insensitive. Only during electrical testing would this condition be detected.

Specifications

Model 761 Central Controller

General Audio:

Frequency Response: digital inputs to monitor outputs loaded with 10 k ohms

32 to 48 kHz Sample Rate: 20 Hz-20 kHz
±0.05 dB

88.2 to 96 kHz Sample Rate: 20 Hz-40 kHz
±0.05 dB

176.4 to 192 kHz Sample Rate: 20 Hz to 40 kHz
±0.05 dB; down 0.5 dB at 80 kHz

Distortion (THD+N): 0.004%, ref 1 kHz, +4 dBu output

S/N Ratio: 86 dB, ref +4 dBu output

Dynamic Range: greater than 106 dB

Crosstalk: 104 dB at 1 kHz; 90 dB at 20 kHz,
ref -1 dBFS input

Digital Audio Inputs: 9

Configuration: organized as two 5.1 surround, one 2-channel stereo, and two dual-channel monaural

Supported Sample Rates: 32, 44.1, 48, 88.2, 96, 176.4, and 192 kHz

Word Length: 24 bit

Type: AES3id-2001 (SMPTE 276M)

Impedance: 75 ohms, unbalanced

Reference Level: -20, -18, -16, or -14 dBFS, selectable

Sync Source: all inputs independently self-clocking

Monitor Outputs: 8

Configuration: organized as one 5.1 surround and one 2-channel stereo

Type: electronically balanced, compatible with balanced or unbalanced loads

Maximum Level: +26 dBu into 600 ohms or greater

Nominal Level, Channels 1-6 (5.1 Surround):
0 or +4 dBu, selectable

Nominal Level, Channels 7 and 8 (Director Cue):
-12, -6, 0, or +4 dBu, selectable

Dolby E Metadata Input:

Type: RS-485/RS-422

Data Rate/Format: 115.2 kbit/s, 8-N-1

Remote Control Inputs: 4

Function: remote mute all, remote dim, two spare

Type: +5 V logic, activates on closure to system common

AC Mains Requirement: 100, 120, or 220/240 V, ±10%, factory configured, 50/60 Hz, 30 watts maximum

Connectors:

Digital Audio Inputs: 9, 75 ohm BNC (per IEC 60169-8 Amendment 2)

Monitor Outputs: 25-pin D-subminiature female

Control Console: 9-pin D-subminiature female

Metadata and Remote Control Input: 9-pin D-subminiature female

AC Mains: 3-blade, IEC 320 C14-compatible (mates with IEC 320 C13)

Dimensions (Overall):

19.00 inches wide (48.3 cm)

1.72 inches high (4.4 cm)

8.75 inches deep (22.2 cm)

Mounting: one space in a standard 19-inch rack

Weight: 8.8 pounds (4.0 kg)

Model 771 Control Console

Application: supports Model 761 Central Controller

Power: +12 volts DC, 100 mA maximum, provided by Model 761 Central Controller

Control Data:

Type: RS-485

Data Rate/Format: 115.2 kbit/s, 8-N-1

Connector: 9-pin D-subminiature female

Dimensions (Overall):

7.20 inches wide (18.3 cm)

2.20 inches high (5.6 cm)

5.40 inches deep (13.7 cm)

Weight: 1.7 pounds (0.8 kg)

Specifications and information contained in this User Guide subject to change without notice.

Appendix A

Target Application

The StudioComm for Surround Models 761 and 771 were designed in conjunction with a major North American television broadcast network. While the system supports their direct application, many features were also included to support the needs of a broad group of potential users. The one area that the “761/771” does exactly match the needs of this network is in the channel input designations and the monitor output assignments. A summary of that information may prove to be interesting reading. Note that Model 761’s Surround A C/LFE and LS/RS inputs are not used for this application.

Channel Group Description: Standard Definition (SD) Audio

| Channel | Type | Description | Model 761 Input Connection | Model 761 Monitor Output Connection |
|---------|----------|-------------------------------|----------------------------|-------------------------------------|
| 1 | Stereo | Left (L) | Surround A L/R | 5.1 L (Channel 1) |
| 2 | Stereo | Right (R) | Surround A L/R | 5.1 R (Channel 2) |
| 3 | Monaural | Secondary Audio Program (SAP) | Stereo A L/R | 5.1 C (Channel 3) |
| 4 | Monaural | International | Stereo A L/R | 5.1 C (Channel 3) |
| 5 | Monaural | Director Cue | Stereo C L/R | Stereo L (Channel 7) |
| 6 | Monaural | Future Use | Stereo C L/R | Stereo R (Channel 8) |
| 7 | --- | Future Use | --- | --- |
| 8 | --- | Future Use | --- | --- |

Channel Group Description: High Definition (HD) Audio

| Channel | Type | Description | Model 761 Input Connection | Model 761 Monitor Output Connection |
|---------|----------|---------------------------------|----------------------------|-------------------------------------|
| 1 | 5.1 | Left (L) | Surround B L/R | 5.1 L (Channel 1) |
| 2 | 5.1 | Right (R) | Surround B L/R | 5.1 R (Channel 2) |
| 3 | 5.1 | Center (C) | Surround B C/LFE | 5.1 C (Channel 3) |
| 4 | 5.1 | Low-Frequency Enhancement (LFE) | Surround B C/LFE | 5.1 LFE (Channel 4) |
| 5 | 5.1 | Left Surround (LS) | Surround B LS/RS | 5.1 LS (Channel 5) |
| 6 | 5.1 | Right Surround (RS) | Surround B LS/RS | 5.1 RS (Channel 6) |
| 7 | Monaural | Secondary Audio Program (SAP) | Stereo B L/R | 5.1 C (Channel 3) |
| 8 | Monaural | International | Stereo B L/R | 5.1 C (Channel 3) |

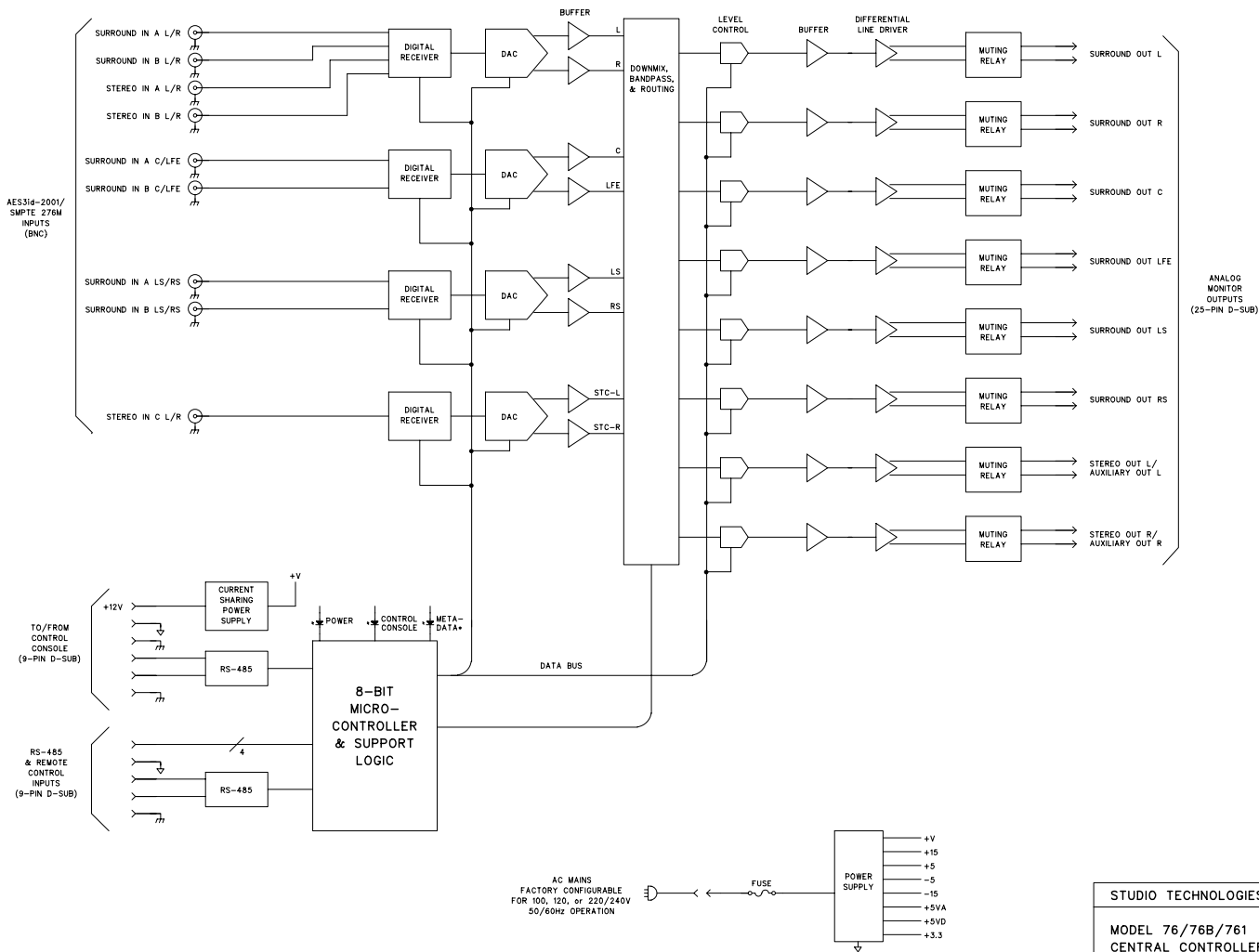

• FOR MODELS 76B AND 761 ONLY

M76BD_C

| | | |
|---|----------|----------|
| STUDIO TECHNOLOGIES, INC. | | |
| MODEL 76/76B/761 CENTRAL CONTROLLER BLOCK DIAGRAM | | |
| DRAWING NO. | DATE | PAGE |
| 31308 | 02/14/08 | 01 of 01 |

TO/FROM
CENTRAL
CONTROLLER

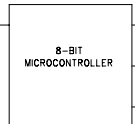
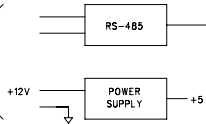

DATA BUS

DATA BUS

OUTPUT LEVEL

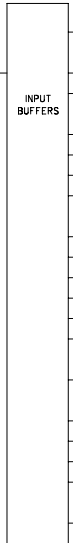

- OUTPUT ENABLE
- 5.1 TO STEREO
- STEREO TO MONO
- HD/SD
- PRIMARY
- SAP
- INTL
- L
- R
- C
- LFE
- LS
- RS
- DISPLAY MODE
- DIALNORM ENABLE
- REFERENCE LEVEL
- MUTE ALL
- DIM
- CONFIG

DIRECTOR
CUE

DOWNMIX

INPUT

CHANNEL
SOLO

OUTPUT

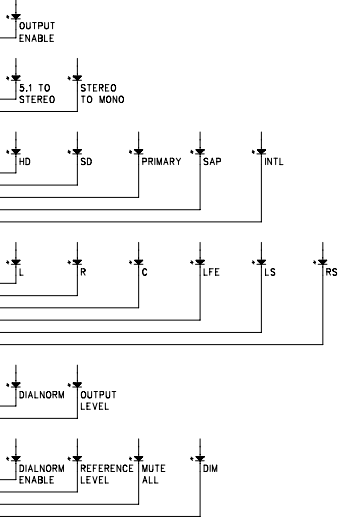
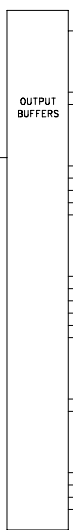

M771BD_B

| | | | |
|---|----------|------|-------|
| STUDIO TECHNOLOGIES, INC. | | | |
| MODEL 771 CONTROL CONSOLE BLOCK DIAGRAM | | | |
| DRAWING NO. | DATE | PAGE | |
| 31316 | 03/26/08 | 01 | OF 01 |

