

Model 5512A Audio Interface

User Guide

Issue 5, March 2026

This User Guide is applicable for serial numbers:

M5512A-01-00151 and later with
Main MCU Firmware v1.06 and later
FPGA Firmware v1.03 and later
ST 2110 (ZMAN) Firmware v1.12 (v1.9.0b62901)

M5512A-02-00151 and later with
Main MCU Firmware v1.06 and later
FPGA Firmware v1.03 and later
ST 2110 (ZMAN) Firmware v1.12 (v1.9.0b62901)

Copyright © 2026 by Studio Technologies, Inc., All rights reserved
studio-tech.com

This page intentionally left blank.

Table of Contents

Revision History.....	4
Introduction.....	5
Installation	8
ST 2110 Configuration.....	11
Model 5512A Configuration	12
Operation.....	27
Technical Notes	33
Specifications	37
Appendix A – Connection Pin-Out Charts.....	39
Appendix B – Source Selection Overview	40
Appendix C – Front-Panel Menu Structure.....	41
Appendix D – ST 2110 (ZMAN) Firmware Update Screen	42
Appendix E – Advanced ST 2110 (ZMAN) General Settings Screens	46
Appendix F – Default Configuration Values.....	47
Appendix G – Accessing the Unit when User Name and/or Password are Not Known ..	48

Revision History

Issue 5, March 2026:

- Documents ST 2110 configuration using the MGMT Ethernet interface.
- Miscellaneous corrections.

Issue 4, August 2025:

- Documents revised Home and ST 2110 menu pages. (Adds ZMAN module temperature.)

Issue 3, July 2025:

- Documents changes made to Home and ST 2110 menus (slight text revisions and new screenshots).
- Documents new ZMAN temperature menu page on front panel.
- Updates Appendix C–Front-Panel Menu Structure.

Issue 2, June 2025:

- Miscellaneous changes and corrections.

Issue 1, May 2025:

- Initial release of document.

Introduction

The Model 5512A Audio Interface provides a simple yet high-performance means of interfacing analog signals with applications that utilize the SMPTE® ST 2110 suite of standards to implement audio-over-Ethernet networking connectivity. Redundant stream performance is also supported following the ST 2022-7 standard. Line-level analog sources can be connected to the unit and then output in the digital domain by way of the Ethernet network interfaces. Digital audio signals, which also arrive by way of the Ethernet network interfaces, are converted to analog and then output as balanced line-level signals. For application troubleshooting, a configuration choice allows a sine wave tone or the analog inputs to be selected as the source for the analog output channels. The Model 5512A is available in two versions – one with eight input and eight output channels and the other with sixteen input and sixteen output channels.

The Model 5512A is a fully professional product that offers the audio quality, features, and reliability required for 24-hour on-air and commercial applications. The analog inputs and analog outputs use two or four 25-pin female D-subminiature connectors for easy interfacing with balanced and unbalanced sources and destinations.

The line-level analog audio input signals are converted to 24-bit PCM digital and then transported via the Ethernet interfaces. Digital audio sources associated with ST 2110-compliant devices can be routed to the Model 5512A, converted to analog, and provided to users as balanced line-level outputs. Configuration and routing of the audio signals can be performed using the Model 5512A's internally provided webpages or JSON API commands. In addition, NMOS and ANEMAN network management can also be utilized.

The Model 5512A provides three Gigabit Ethernet (GbE) network interfaces, two to support redundant

operation following the ST 2022-7 standard and the third for accessing the management menu system. The internal web server allows fast and flexible monitoring and configuration of the unit's networking and audio performance. Front-panel indicators, a backlit LCD display, and pushbutton switches provide users with direct access to key operating parameters.

The Model 5512A can be powered by 100-240 V, 50/60 Hz AC mains or a source of 12 volts DC. Both can be simultaneously connected to provide redundant operation. The unit's lightweight enclosure mounts in one space (1U) of a standard 19-inch rack. Industry-standard connectors are used for the audio input, audio output, Ethernet, AC mains, and DC power interconnections.

ST 2110 is finding wide acceptance as an audio, video, and ancillary data transport “backbone” due to its interoperability, flexibility, and support by a large number of equipment manufacturers. The Model 5512A can serve as an “edge” device for ST 2110-compliant implementations, providing high-performance line-level analog input and analog output resources in a compact, cost-effective package. The unit can also serve as a general-purpose audio “tool” to help extend ST 2110 capabilities to facilities and applications that were initially implemented to support signals in the analog domain.

Audio over Managed IP Networks

Digital audio data associated with the Model 5512A is interfaced with local area network (LAN) connections following the SMPTE ST 2110 standards. A highlight of ST 2110 is its ability to utilize any standard Ethernet network implementation, including switches, to directly transport professional audio signals. For signal integrity the Model 5512A supports redundant audio data streams per the ST 2022-7 standard. The unit supports digital audio signals with a sampling rate of 48 or 96 kHz and a bit depth of 24. This ensures compatibility with virtually all broadcast, production, industrial, and commercial applications.



Figure 1. Model 5512A Audio Interface front view

Network Interfaces

The Model 5512A's Primary + Control (PRI+CTRL) and Secondary (SEC) Ethernet interfaces can be utilized for 2022-7 Redundant Stream applications. The third Ethernet interface, named Management (MGMT), will always be used to access the unit's management webpages. This Ethernet interface can be connected to an independent network that some facilities implement for equipment monitoring and maintenance purposes. The unit's management web server can also be connected to the network that is being used for ST 2110 operation. This would function correctly since the management web server will always have a unique IP address that would not interact with audio and related data. Status LEDs, located on the unit's back panel, provide a real-time indication of LAN performance.

Applications

Two versions of the Model 5512A Audio Interface are available. The Model 5512A-01 provides eight line-level analog inputs and eight line-level analog outputs. The Model 5512A-02 provides sixteen line-level analog inputs and sixteen line-level analog outputs. Both units are general-purpose interface devices intended for a variety of audio and audio-for-picture applications that utilize the ST 2110 suite of standards. Each is suitable for use in demanding on-air broadcast and live-event applications that require both solid audio performance and reliable operation. Model 5512A units feature an optimized set of controls and indicators that make them simple and intuitive to use. Rack-mounted in 1U, the units are appropriate for installation in fixed locations, serving the needs of systems associated with post-production, content distribution, education, commer-

cial, and government facilities. The lightweight enclosure also makes it suitable for mobile and field uses.

ST 2110 Networking

The Model 5512A's ST 2110 interface supports conformance levels A, B, C, AX, BX, and CX in single and redundant streams. The latter follows the SMPTE ST 2022-7 standard and allows connection of one or two networks as desired. The Primary + Control (PRI+CTRL) Ethernet interface allows configuration of the ST 2110 interface by way of webpages. NMOS support that follows the IS-04 and IS-05 standards is also provided. The Merging Technologies ANEMAN Audio Network Manager application can also be utilized as can a JSON API.

Studio Technologies has not fully explored the Model 5512A's ability to support RAVENNA and AES67. The ST 2110 capabilities in the Model 5512A are provided by the ZMAN module from Merging Technologies. The ZMAN specifications indicate full compatibility with RAVENNA and AES67. As such, Model 5512A ST 2110 audio channels should be directly compatible with AES67 audio channels. (Actually, our impression is that ST 2110 audio was based on ensuring compatibility with AES67.)

RAVENNA is also, depending on its configuration, directly compatible with AES67. So, in theory, the Model 5512A can serve as an ST 2110, RAVENNA, and AES67 interface. Settings in the ZMAN-provided configuration webpages may have to be selected specifically for compatibility with RAVENNA or AES67, but the required parameters should be able to be selected. Over time, Studio Technologies will explore this subject further and a conversation with factory personnel may provide additional clarity.



Figure 2. Model 5512A-01 Audio Interface back view



Figure 3. Model 5512A-02 Audio Interface back view

Analog Inputs

Depending on the version selected, the Model 5512A provides either eight or sixteen analog inputs that are compatible with balanced or unbalanced line-level sources. The input signals are converted to digital and then output via an Ethernet network as part of an ST 2110-30 IP stream. Compatible signal sources include audio consoles, wireless microphone receivers, broadcast playback equipment, and output ports on matrix intercom systems.

The analog inputs are electronically balanced (differential), capacitor-coupled, and ESD (static) protected for reliable operation in demanding applications. Extensive filtering minimizes the chance that radio frequency (RF) energy will cause interference. The analog inputs are also protected from damage should a moderate DC voltage be accidentally connected. These characteristics make the analog inputs suitable for use in studio and mobile facilities as well as field-deployed environments.

The audio performance of the Model 5512A's analog inputs is very good. Low-noise, wide dynamic-range circuitry ensures that audio quality is preserved. The audio signals are routed to high-performance analog-to-digital conversion (ADC) sections that support a sampling rate of 48 or 96 kHz and a bit depth of 24. A precision voltage-reference circuit helps the ADC circuitry perform highly accurate signal conversion. The audio signals, now in the digital domain, are packetized and prepared for transport over Ethernet networking.

Analog Outputs

The selected Model 5512A version will provide either eight or sixteen line-level analog output channels. Each channel can be individually configured to use as its input source a ST 2110-30 receiver (input) channel, one of the analog input channels, or a 1 kHz sine wave tone. Refer to the block diagram in Appendix B for details. In most applications, a digital receiver (input) channel associated with the unit's Ethernet interfaces will serve as the audio source. The unit's web interface, JSON API, or ANEMAN software application would be used to select the sources which originate from sender (output) channels on designated ST 2110-compliant equipment.

Another configuration choice allows a signal associated with an analog input to serve as the source for an analog output channel. Useful for troubleshooting purposes, the selected signal would provide an active "loop through" version of its associated analog input signal. Also, for troubleshooting purposes a 1 kHz sine wave tone can be assigned to be the source for any analog output channel. The resulting output would be a steady tone with a nominal level of +4 dBu.

The Model 5512A's analog outputs have a maximum level of +24 dBu. This allows both compatibility and sufficient headroom for use in applications where digital audio signals with a nominal level of -20 dBFS need to translate into analog signals that have a nominal level of +4 dBu. For flexibility, a configuration menu choice allows the level of each analog output channel to be individually adjusted ("trimmed") over a range of ± 20 dB in 1-dB steps. This ensures that the Model 5512A will also be compatible in environments that utilize 0, +4, +6, or even +8 dBu nominal output levels.

The analog outputs are electronically balanced, capacitor-coupled, and ESD (static) protected. High-quality components, including the important digital-to-analog (DAC) converters, are used to provide low-distortion, low-noise, and sonically excellent performance. Robust circuitry provides protection from damage should a moderate DC voltage be accidentally connected, something especially useful in broadcast applications. The analog outputs are compatible with virtually all balanced and unbalanced loads with an impedance of 2 k ohms or greater.

Simple Installation

The Model 5512A uses standard connectors to allow fast and convenient interconnections. Multiple 25-pin female D-subminiature connectors are used to interface with the analog input and analog output signals. The unit connects to local area networks (LANs) using three RJ45 jacks. Multiple LEDs on the unit's back panel display the status of the network connections. A detachable power cord is used to connect a source of AC mains power. A DC power source would interface using a 4-pin XLR connector. The lightweight aluminum enclosure mounts in one space (1U) of a standard 19-inch rack enclosure.

Operating Power

The Model 5512A allows an AC mains source of 100-240 V, 50/60 Hz to be connected by way of a standard detachable AC mains power cord. It can also be DC powered using a 10-16-volt source that is connected via a broadcast-standard 4-pin XLR connector. If both AC and DC power sources are connected, the unit will be powered by the AC mains supply. Only if the AC mains source fails will a load be placed on the DC source. This allows a source of DC, such as a battery pack, to serve in a backup capacity. With this arrangement, normal operation can continue even if AC mains power is lost.

Future Capabilities and Firmware Updating

The Model 5512A was designed so that its capabilities can be easily updated and enhanced in the future. A USB host connector, located on the unit's back panel, allows the main MCU application and FPGA (programmable-logic) firmware (embedded software) to be updated using a USB flash drive. A Merging Technologies ZMAN module is used to implement the Model 5512A's ST 2110 functionality. The module's firmware can be updated using a web browser connected to the Ethernet interface dedicated to ST 2110 control use. All software files and configuration parameters are stored in non-volatile memory.

Installation

In this section, the Model 5512A Audio interface will be mounted in one space (1U) of an equipment rack. Ethernet network connections will be made using RJ45 jacks. Analog line-level input and output signals can be connected. AC mains and/or DC power will be connected.

Up to three Gigabit Ethernet data connections will be made to the Model 5512A using standard RJ45 patch cables. Connections to the analog input and output channels will be made using 25-pin D-subminiature connectors. AC mains power can be connected to the Model 5512A by means of a detachable cord set that is compatible with the unit's 3-pin IEC 320 C14 inlet connector. Some applications may warrant connection to a source of nominal 12 volts DC which can be made by way of a 4-pin XLR connector. The DC source can be used to power the Model 5512A

or it can serve as a backup power source should AC mains be connected.

What's Included

The shipping carton contains a Model 5512A Audio Interface and instructions on how to obtain an electronic copy of this guide. Also included in the shipping carton is a North-American-standard AC mains cord. For destinations outside of North America the local reseller or distributor should provide an appropriate AC mains cord.

Mounting the Model 5512A

The Model 5512A Audio interface requires one space (1U) in a standard 19-inch (48.3 cm) equipment rack. Secure the Model 5512A into the equipment rack using two mounting screws per side. As the Model 5512A does not contain a fan or other noise-producing sources it can be located where microphones or other "on air" audio sources will be present. However, keeping the unit away from large sources of electrical noise or significant RF (radio-frequency) fields is probably a good idea.

Ethernet Connections

The Model 5512A provides three Gigabit Ethernet (GbE) interfaces for flexibility and compatibility with many ST 2110 and management networking implementations. Two interfaces are provided for interconnection with one or two local area networks (LANs) associated with ST 2110 audio-over-Ethernet networking schemes. One jack is labeled PRI+CTRL (Primary + Control) and is used for both ST 2110 audio and ST 2110 control (monitoring, configuration, and firmware updating). Another jack, labeled SEC, is provided for use by the secondary ST 2110 audio interface. A third Ethernet interface, labeled MGMT, is dedicated to accessing the Model 5512A's management resources. An internal web server function supports the Model 5512A's management interface's webpages. These webpages are used for configuration, monitoring, and maintenance of Model 5512A operation. The management interface is also used by the factory at the time of Model 5512A manufacture.

By providing three Ethernet interfaces, the Model 5512A allows support for facilities that utilize independent networks for ST 2110 audio transport and equipment management. In this way, "production"

networks that support transport of audio signals by way of a single LAN (for ST 2110 audio) or two LANs (for ST 2110 audio with Redundant Streams operation) can be separate from an engineering network that is used by technical personnel for configuring and maintaining a facility or “plant.”

Connections to the three Ethernet interfaces are made by way of standard RJ45 jacks that are located on the back of the Model 5512A's enclosure. The Ethernet interfaces support auto MDI/MDI-X so that crossover cables are not required.

Twisted-pair (UTP) Ethernet has a 100-meter (325-foot) interconnection cable limitation. This can be overcome by using a fiber-optic interconnection between the Model 5512A and the Ethernet switch or switches in the one or more associated local-area-networks (LANs). This can be easily accomplished using copper-to-fiber-optic media converter units. Commonly available, models are available that will support single- or multi-mode fiber optic cable.

ST 2110 Ethernet Connections

The Model 5512A requires at least one 1000BASE-T Gigabit Ethernet (GbE) connection for ST 2110 operation and configuration. It should be connected to the PRI+CTRL RJ45 jack. A second 1000BASE-T GbE connection can be made to the SEC RJ45 jack if Redundant Streams (ST 2022-7) is desired. This connection would typically be provided by a second physical network. It's also possible that separate VLANs will be created and utilized. Whatever the network arrangement, it's important to note that 100BASE-TX (100 Mb/s) or 10BASE-T (10 Mb/s) Ethernet network connections are not sufficient.

Management Ethernet Connection

An Ethernet signal is required to be connected to the Model 5512A's MGMT jack whenever Model 5512A configuration and management needs to be performed. It's recommended that a 1000BASE-T Gigabit Ethernet (GbE) connection be made but a 100BASE-TX (100 Mb/s) or even a 10BASE-T (10 Mb/s) connection is sufficient. (Gigabit Ethernet will provide the best performance and it's assumed that all contemporary applications will support it.) The management interface can share connectivity with the network that is being used by the unit's ST 2110 Primary + Control network connection. In

this case, a separate physical connection would still be required. This connection can be part of the same LAN that is used for ST 2110 audio, or be a member of a VLAN that has been configured for management purposes. It can also be connected to a separate LAN that is designated for configuring, monitoring, and maintenance.

Analog Audio Connections

Analog signal connections to and from the Model 5512A are made by way of 25-pin female D-subminiature (DB-25F) connectors. One D-sub connector is associated with the Model 5512A-01's eight analog input channels. Two D-sub connectors are associated with the Model 5512A-02's sixteen analog input channels. As might be expected, one D-sub connector is associated with the Model 5512A-01's eight analog output channels. And two D-sub connectors are associated with the Model 5512A-02's sixteen analog output channels. Refer to Figures 2 and 3 for a view of the D-sub connectors that are located on the back panel.

Analog Inputs

The Model 5512A-01 uses one female 25-pin D-subminiature (DB-25F) connector to interface with its eight line-level analog inputs. The connector, located on the unit's back panel, is labeled Analog Inputs 1-8. The Model 5512A-02 provides two female 25-pin D-sub connectors to interface with its sixteen line-level analog inputs. The connectors, located on the unit's back panel, are labeled Analog Inputs 1-8 and Analog Inputs 9-16. Refer to Appendix A for details on the exact pinout of these D-sub connectors.

The wiring scheme used by the D-subminiature connectors comply with AES59-2012, as made popular by TASCAM. A wiring assembly prepared for use with the analog input channels would be identical to a standard TASCAM-type input assembly with the exception of using “locking” screws with 4-40 UNC threads.

Each analog input circuit is electronically balanced and optimized for connection to a balanced or unbalanced source with a nominal signal level of +4 dBu. A configuration selection in one of the Model 5512A's management webpages allows adjustment of the input gain of each individual channel in 0.1-dB steps over a –20.0 to +20.0 dB range. This will allow

the inputs to be made compatible with audio signals that have a wide range of nominal levels. When connecting a consumer-level (“–10 dBV”) audio source adding 12.0 dB of gain to each input might be effective.

Balanced analog sources should be wired so that signal high is connected to +, signal low to –, and shield to the shield connection. With an unbalanced source, connect signal high to the + connection, and shield to both the – and the shield connections. If connecting to an unbalanced analog source in this manner results in hum or noise try connecting signal high to + and shield to –; leave the shield connection unterminated.

Analog Outputs

The Model 5512A-01 uses one female 25-pin D-subminiature (DB-25F) connector to interface with its eight line-level analog outputs. The connector, located on the unit’s back panel, is labeled Analog Outputs 1-8. The Model 5512A-02 provides two female 25-pin D-sub connectors to interface with its sixteen line-level analog outputs. The connectors, located on the unit’s back panel, are labeled Analog Outputs 1-8 and Analog Outputs 9-16. Refer to Appendix A for details on the exact pinouts of these D-sub connectors.

The wiring scheme used by the D-subminiature connectors comply with AES59-2012, as made popular by TASCAM. Wiring assemblies prepared for use with the Model 5512A’s analog output channels should be identical to that of TASCAM-type output assemblies. Note that unlike TASCAM-type assemblies, the Model 5512A’s D-sub connectors use “locking” screws with 4-40 UNC threads.

The analog outputs are electronically balanced and will perform optimally when driving loads of 2 k (2000) ohms or greater. In most applications, 3-pin male XLR connectors will be used to interface with balanced inputs on the associated devices. In this case, a Model 5512A analog output channel’s + terminal would go to pin 2 of the XLR, the – terminal to XLR pin 3, and the shield terminal to XLR pin 1. Balanced connection of the analog output channels is the preferred connection method but unbalanced operation does not pose a problem. To connect to an unbalanced input, connect the Model 5512A’s + terminal as signal high,

and only the Model 5512A’s shield terminal as the signal low/shield. Leave the – terminal unconnected. For correct unbalanced operation it is important not to connect the Model 5512A’s – terminal and shield together.

A level trim configuration selection in one of the Model 5512A’s management webpages allows adjustment of the signal level of each analog output channel in 0.1-dB steps over a –20.0 to +20.0 dB range. This will help to ensure that the analog output channels will be compatible with audio equipment and facilities that have a wide range of nominal levels. In some cases, the analog output level might benefit from being reduced, such as by 10.0 dB, rather than having gain added.

Connecting Power

The Model 5512A requires a source of AC mains or nominal 12 volts DC for operation. Either source can be connected with the same result. Both can be simultaneously connected if a redundant (backup) power scheme is desired.

Connecting AC Mains Power

The Model 5512A can operate directly from an AC mains power source of 100 to 240 volts, 50/60 Hz, 20 watts maximum. As a “universal AC mains input” device there are no switches to set or jumpers to install. A 3-pin IEC 320 C14 connector on the back panel mates with a detachable AC mains cord set.

All units are supplied from the factory with an AC mains cord that has a North-American (NEMA 5-15L) standard plug on one end and an IEC 320 C13 connector on the other end. Units intended for use in other destinations require that an appropriate AC mains cord be obtained. The wire colors in the AC mains cord should conform to the internationally recognized color code and be terminated accordingly:

<u>Connection</u>	<u>Wire Color</u>
Neutral (N)	Light Blue
Line (L)	Brown
Earth/Ground (E)	Green/Yellow

Because the Model 5512A does not contain a power on/off switch it will begin operation as soon as AC mains power is connected.

Safety Warning: The Model 5512A does not contain an AC mains disconnect switch. As such, the plug of the AC mains cord will serve as the disconnection device. Safety considerations require that the plug and associated inlet be easily accessible to allow rapid disconnection of AC mains power should it prove necessary.

Connecting DC Power

The Model 5512A can also operate from a source of 10 to 16 volts DC. The current required from a 12 volts DC source is 1.0 ampere maximum. (1.2 ampere maximum with a 10 volts DC source.) A 4-pin male XLR connector, located on the unit's back panel, is used to connect the source of DC. Prepare a mating connector (female) so that pin 1 is DC- and pin 4 is DC+. Pins 2 and 3 are not used and should remain unconnected. This type of connector and pinout have become a broadcast DC power standard and should be familiar to many technical personnel. Because the Model 5512A contains no power on/off switch it will begin operation as soon as a DC power source is connected.

As previously mentioned, both an AC mains source and a DC power source can be connected at the same time. If this is the implementation, the AC mains source will always power the Model 5512A with the DC source serving as a "hot standby." Only if the AC source fails will the unit draw significant power from the DC source. This will occur automatically with no interruption of Model 5512A operation. In this "standby" mode (when an AC mains source is connected), the Model 5512A will draw less than 120 micro-amperes (uA) from a connected 12 volts DC source.

ST 2110 Configuration

The Model 5512A's ST 2110 interface is implemented by way of a ZMAN module from Merging Technologies of Switzerland. The ZMAN module is installed in the Model 5512A's DFB card and is accessed using the PRI+CTRL Ethernet interface which is located on the unit's back panel. A standard web browser running on a personal computer communicates with the ZMAN module utilizing webpages that are provided by ZMAN's web server capability.

To access the webpages is simple. Begin by identifying the Model 5512A's PRI+CTRL interface's IP address using the front-panel menu system. On the web browser's command line, enter the IP address followed by **/advanced**. As an example, if the IP address of the PRI+CTRL interface is 192.168.1.169 then one would enter **192.168.1.169/advanced** to access the webpages.

Once the correct address and suffix have been submitted by way of the web browser, the ZMAN module will provide a webpage. This page will have approximately ten tabs that allow many ZMAN features to be shown and often configured. Refer to Appendix E for a representative view of the Advanced ZMAN General Settings Screen.

Clocking selections can be found by accessing the PTP tab. The Session Sources tab allows the Model 5512A's ST 2110 sender (output) channels to be shown and configured. The Session Sinks tab allows the Model 5512A's receiver (input) channels to be shown and configured. Also provided is a tab for NMOS configuration.

For an overview of how to configure the Model 5512A's ST 2110 capabilities, refer to the short video that was created by Studio Technologies' personnel for the similar Model 5682 ST 2110 to Dante Bridge product. A link to this Quick Start Guide video can be found in the Model 5682 product page on the Studio Technologies' website (studio-tech.com) under the Documentation, Videos section.

MGMT Ethernet Interface Configuration

It is technically possible to access the ZMAN module's configuration webpages using the Model 5512A's MGMT (management) Ethernet interface. (Normally they are accessed by way of the Model 5512A's PRI+CTRL Ethernet interface as previously discussed.) Accessing these webpages by way of the MGMT Ethernet interface might be useful when "out of band" ST 2110 configuration is desired. The actual command used to access ZMAN's webpages via the MGMT Interface is slightly different from that used to access them using the PRI+CTRL interface.

The first step is to obtain the IP address of the ZMAN module as it is associated with the MGMT interface. This can be obtained by accessing the ZMAN module using the PRI+CTRL Ethernet interface (as previously discussed). Using a web browser to access the ZMAN's webpages, the General tab will display. At the bottom of the General tab will be a list of ZMAN interfaces and each of their corresponding IP addresses. The address for interface 3 is what is desired. (Interface 3 is the ZMAN port that connects to the Model 5512A's MGMT interface.) Write down or otherwise record interface 3's IP address for use in the following step. Now, using a web browser that is connected to the MGMT Ethernet interface, enter the IP address for ZMAN interface 3 followed by **:82/advanced** to access ZMAN's webpages. As an example, if the interface 3's IP address is 192.168.1.171, one would enter **192.168.1.171:82/advanced** to access ZMAN's configuration webpages from the MGMT Ethernet interface.

Model 5512A Configuration

Many of the Model 5512A's operating parameters can be configured using the webpages that are provided by way of the Model 5512A's management Ethernet interface. A standard web browser is all that is required to utilize the menu webpages. Of course, the device hosting the web browser must be part of the same network that includes the Model 5512A's management Ethernet interface. The management interface's network configuration can be revised using one of the webpages or by way of the front-panel menus.

Management IP Address

With the Model 5512A powered and operational, and a network connection made to the management Ethernet interface, a connection to the web server can typically be established. How the management Ethernet interface obtains its IP address will depend on a configuration setting. The default configuration method is automatic such that from the factory the Model 5512A's management interface will first try to obtain an IP address using DHCP. If that is not successful, an IP address will be assigned using the link-local protocol. (A link-local-obtained IP address

will be in the format of 169.254.x.x.) It's also possible that the Model 5512A may have been configured to use a manual (fixed or static) IP address. The Model 5512A's management webpages can be used to review or make changes to the IP address and related parameters. Alternately, the front-panel display and associated pushbutton switches can be utilized.

It should be simple to identify the active management IP address. Press the front-panel down button four times to view the menu that shows the current management IP address. To minimize the chance of screen damage ("burn in"), the unit includes a screen-saver function. It will automatically invoke two minutes after the last press of a front-panel button. When active, it will cause a continuous sequence of two pages to show on the front panel. Both will show the Studio Technologies logo, but one reverses the graphics bits from black to white and vice versa. Pressing the down button four times, even when the screen saver is active, will cause the active management IP address screen to be shown.

Accessing the Management Webpages

To access the Model 5512A's management home page, type the Model 5512A's management IP address into the browser's search bar. (It's possible that some browsers may require the text **http://** followed by the IP address.)

Home Menu

Once the Home page is shown, a number of Model 5512A operating parameters will be presented. This includes the ST 2110 device name, the unit's overall status, sampling rate, frame size (packet time), and ZMAN module temperature. (This module provides the ST 2110 interface.) Also shown are the link, IP, and PTP status of the two Ethernet interfaces that are provided for ST 2110 operation.

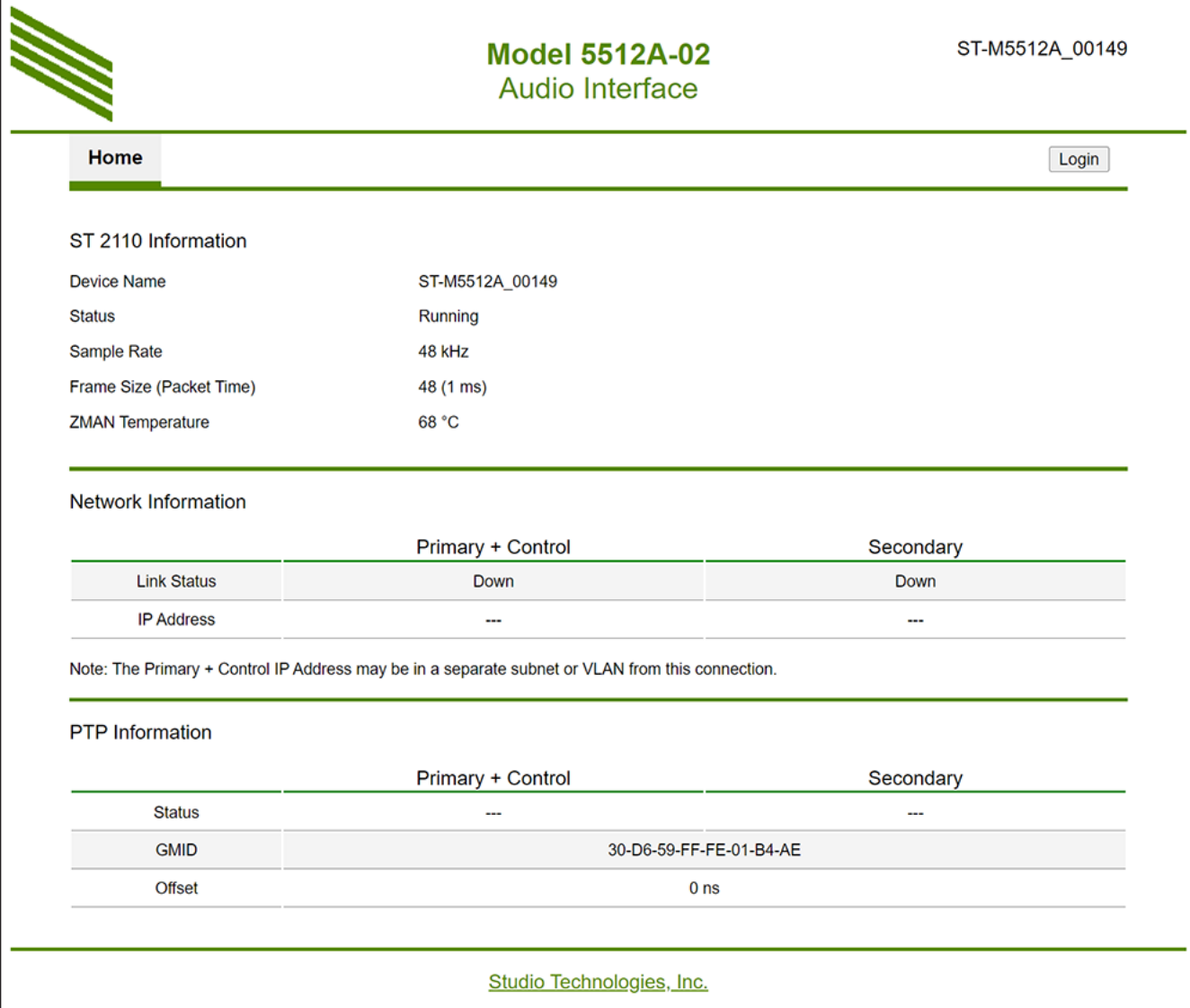

The screenshot shows the Home Menu for the Model 5512A-02 Audio Interface. The page title is "Model 5512A-02 Audio Interface" and the device ID is "ST-M5512A_00149". A "Home" tab is selected, and a "Login" button is visible in the top right corner.

ST 2110 Information

Device Name	ST-M5512A_00149
Status	Running
Sample Rate	48 kHz
Frame Size (Packet Time)	48 (1 ms)
ZMAN Temperature	68 °C

Network Information

	Primary + Control	Secondary
Link Status	Down	Down
IP Address	---	---

Note: The Primary + Control IP Address may be in a separate subnet or VLAN from this connection.

PTP Information

	Primary + Control	Secondary
Status	---	---
GMID	30-D6-59-FF-FE-01-B4-AE	
Offset	0 ns	

[Studio Technologies, Inc.](#)

In addition, access to the configuration menus is also possible. Click on the link labeled Login, on the page's right side, and it will lead to the Login menu webpage. The entry of a valid user name and password is now required. This is not a sophisticated security implementation. It is intended to keep "honest" people from making unauthorized or unintentional changes to the configuration of the Model 5512A.

Login Menu

Model 5512A-02
Audio Interface

ST-M5512A-02_00149

Home **Login**

User Name

Password

[Studio Technologies, Inc.](#)

User Name: Enter the Model 5512A's user name into this field. It is case sensitive. The default user name is **guest**. If the default user name and default password are active, the default user name will show in this field.

Password: Enter the Model 5512A's password into this field. It is case sensitive. The default password is **guest**. If the default user name and default password are active, the default password will show in this field.

Login Button: Click on the **Login** button to submit the entered user name and password. If the correct entries have been made, access to the configuration menu webpage will show. If an incorrect user name and/or password is entered, a login failed message will be shown.

ST 2110 Menu

Once a correct user name and password combination have been submitted, the ST 2110 menu webpage will show. In addition to showing the previously mentioned ST 2110 operating parameters, it includes one configurable parameter and one reboot function. This menu also shows tabs for accessing the other menus which allow many Model 5512A configuration choices to be shown and, in many cases, revised.



Model 5512A-02

Audio Interface

ST-M5512A_00149

ST 2110
Analog Inputs
Analog Outputs
Network
Access
System

ST 2110 Information

Device Name	ST-M5512A_00149
Status	Running
Sample Rate	48 kHz
Frame Size (Packet Time)	48 (1 ms)
ZMAN Temperature	67 °C
Senders Source	<input style="width: 80%;" type="text" value="Analog Inputs"/> <input type="button" value="Submit"/>

Network Information

	Primary + Control	Secondary
Link Status	Down	Down
IP Address	---	---

Note: The Primary + Control IP Address may be in a separate subnet or VLAN from this connection.

PTP Information

	Primary + Control	Secondary
Status	---	---
GMID	30-D6-59-FF-FE-01-B4-AE	
Offset	0 ns	

ST 2110 Reboot

[Studio Technologies, Inc.](http://www.studio-tech.com)

ST 2110 Senders Source

Choices are: *Analog Inputs*, *ST 2110 Receivers*, and *1 kHz Tone*.

There are eight ST 2110 sender (output) channels associated with the Model 5512A-01 and sixteen ST 2110 sender (output) channels associated with the Model 5512A-02. The signal sources for these sender (output) channels, as a group, can be selected from among three choices. Refer to the block diagram in Appendix B for details. Selecting *Analog Inputs* is the usual setting. This will cause the Model 5512A-01 to use analog inputs 1-8 as the sources for ST 2110 sender (output) channels 1-8 and the Model 5512A-02 to use analog inputs 1-16 as the sources for ST 2110 sender (output) channels 1-16. These are connected one-to-one, with analog input 1 routed to sender (output) channel 1, analog input 2 routed to sender (output) channel 2, and so forth.

Selecting *ST 2110 Receivers* causes the Model 5512A's ST 2110 receiver (input) channels to be used as the signal sources for the ST 2110 sender (output) channels. The channels are mapped one-to-one, with receiver channel 1 routed to output channel 1, receiver channel 2 routed to output channel 2, etc. This setting can be considered as an ST 2110 loopback function that would typically only be used for test purposes.

Selecting *1 kHz Tone* causes a precise 1000 Hz (1 kHz) sine-wave tone with a level of -20 dBFS to be present on all of the Model 5512A's ST 2110 sender (output) channels. This is an excellent method of providing a known signal source on all of the output channels and should prove useful in test and troubleshooting situations. The Model 5512A does not allow the frequency and output level of the tones to be adjusted.

Submit: A Submit button is located below the source selection box. To save the selected choice requires that the **Submit** button be pressed.

Reboot ST 2110

A check box and a reboot button are associated with the ST 2110 reboot function. This function is provided to allow a user to force the ST 2110 interface to restart (reboot) operation. (The ST 2110 interface is provided by the ZMAN module.) The reboot box must be selected prior to pressing the associated **Reboot** button.

Analog Inputs Menu

The Model 5512A-01 provides eight analog inputs while the Model 5512A-02 provides sixteen. They function similarly. As such, independent text sections will not be provided to describe their operation.

The screenshot shows the web interface for the Model 5512A-02 Audio Interface. At the top, there is a logo on the left, the title 'Model 5512A-02 Audio Interface' in the center, and the device ID 'ST-M5512A-02_00149' with an 'Identify Device' button on the right. Below this is a navigation bar with tabs for 'ST 2110', 'Analog Inputs' (which is highlighted), 'Analog Outputs', 'Network', 'Access', and 'System'. A 'Log Out' button is located on the far right of the navigation bar. The main content area is titled 'Level Adjustments' and contains a table with 16 rows. Each row has a 'Channel' column (numbered 01 to 16) and a 'Gain (±dB)' column with a text input field containing '0.0'. A 'Submit' button is positioned below the table. At the bottom of the interface, the text 'Studio Technologies, Inc.' is displayed.

Channel	Gain (±dB)
01	0.0
02	0.0
03	0.0
04	0.0
05	0.0
06	0.0
07	0.0
08	0.0
09	0.0
10	0.0
11	0.0
12	0.0
13	0.0
14	0.0
15	0.0
16	0.0

Level Adjustments – Gain

The circuitry associated with the Model 5512A's analog input channels can have their gain individually adjusted (trimmed). The channels are labeled 01 through 08 for the Model 5512A-01 and 01 through 16 for the model 5512A-02. Each channel allows its gain to be adjusted from -20.0 to $+20.0$ in 0.1 -dB steps. These gain trim functions can be used to allow

the relative level of the analog input sources to be matched. They can also be used to compensate for signals that don't match the Model 5512A's analog inputs' nominal level of $+4$ dBu.

Submit: A Submit button is located below the field for the unit's last channel. To save changes made to any of the gain fields requires that the **Submit** button be pressed.

Analog Outputs Menu

The Model 5512A-01 provides eight analog output channels while the Model 5512A-02 provides sixteen. They function similarly, the only difference being the number of output channels.

Model 5512A-02
Audio Interface

ST-M5512A-02_00149

ST 2110 Analog Inputs **Analog Outputs** Network Access System

Level Adjustments

Channel	Gain (\pm dB)
01	<input type="text" value="0.0"/>
02	<input type="text" value="0.0"/>
03	<input type="text" value="0.0"/>
04	<input type="text" value="0.0"/>
05	<input type="text" value="0.0"/>
06	<input type="text" value="0.0"/>
07	<input type="text" value="0.0"/>
08	<input type="text" value="0.0"/>
09	<input type="text" value="0.0"/>
10	<input type="text" value="0.0"/>
11	<input type="text" value="0.0"/>
12	<input type="text" value="0.0"/>
13	<input type="text" value="0.0"/>
14	<input type="text" value="0.0"/>
15	<input type="text" value="0.0"/>
16	<input type="text" value="0.0"/>

Analog Outputs Source

[Studio Technologies, Inc.](#)

Level Adjustments – Gain

The circuitry associated with the Model 5512A's analog output channels can have their gain individually adjusted (trimmed). The channels are labeled 01 through 08 for the Model 5512A-01 and 01 through

16 for the model 5512A-02. Each channel allows its output gain to be adjusted from -20.0 to $+20.0$ in 0.1 -dB steps. These gain trim functions can be used to allow the relative level of each analog output channel to be matched. They can also be used to adjust the

analog output levels such that their nominal level is something different than the unit's default nominal level of +4 dBu. (The default nominal level is achieved with a gain level setting of 0 dB.) The level adjustment settings will apply to each analog output channel, no matter what signal source has been selected. This means that the level trim settings will apply to their associated analog outputs whether the analog inputs, the Dante receiver (input) channels, or the 1 kHz tone generator is serving as the audio sources.

Submit: A Submit button is located below the field for the unit's last channel. To save changes made to any of the gain fields requires that the **Submit** button be pressed.

Analog Outputs Source

Choices are: *Analog Inputs*, *ST 2110 Receivers*, and *1 kHz Tone*.

The Model 5512A is unique in that the analog outputs can have their source selected from among three choices. Refer to the block diagram in Appendix B for details. Selecting *Analog Inputs* as the source for an analog line outputs will create what an audio console would consider to be a direct out functions. The output of the circuitry associated with each input circuit will be the source for the associated analog output. While probably not the typical setting, it can be useful for special applications including during installation, deployment, and testing.

Selecting *ST 2110 Receivers* is the usual setting, configuring a Model 5512A to use the ST 2110 receiver (input) channels as the signal sources for the analog output channels.

Selecting *1 kHz Tone* makes a 1000 Hz (1 kHz) sine-wave tone with a level of +4 dBu nominal be present on the analog output channels. This is an excellent method of providing a known signal on the analog output channels and is expected to be useful for test situations. The Model 5512A does not allow the frequency of the tone to be adjusted.

Submit: A Submit button is located below the configuration fields. To save changes made to any of the fields requires that the **Submit** button be pressed.

Network Menu



Model 5512A-02
Audio Interface

ST-M5512A-02_00149
Identify Device

ST 2110
Analog Inputs
Analog Outputs
Network
Access
System

Log Out

Current Network Information

Reload

	Primary + Control	Secondary	Management
Link Status	Down	Down	Up
IP Address	---	---	192.168.1.253
Subnet Mask	---	---	255.255.255.0
Gateway	---	---	192.168.1.1
MAC Address	30-D6-59-01-BE-59	30-D6-59-81-BE-59	00-04-22-F4-00-95

Management Interface Configuration

IP Configuration Automatic ▾

Manual IP Address

Manual Subnet Mask

Manual Gateway

Submit

[Studio Technologies, Inc.](#)

Current Network Information

Each Model 5512A has three Ethernet interfaces: Primary + Control, Secondary, and Management. Three columns, each consisting of five fields, provides important network information about each interface.

Link Status: These are display-only fields that show the link status associated with each Ethernet interface. The text shown will either be **Starting**, **Down**, or **Up**. *Starting* indicates that the ZMAN module (used to implement the ST 2110 interface) is in the process of booting (starting) up. *Down* indicates that a connection to an Ethernet interface has not been established. *Up* indicates that a connection to an Ethernet interface has been established.

IP Address: These are display-only fields that show the IP address associated with each Ethernet interface. Shown in dot-decimal notation.

Subnet Mask: These are display-only fields that show the subnet mask value associated with each Ethernet interface. Shown in dot-decimal notation.

Gateway: These are display-only fields that show the gateway address associated with each Ethernet interface. Shown in dot-decimal notation.

MAC Address: These are display-only fields that show the MAC (media access control) address associated with each Ethernet interface. These are unique hardware identification numbers that are assigned to each specific Model 5512A Ethernet interface.

Management Interface Configuration

The method used by the management Ethernet interface to obtain its IP address can be selected. Specific values can be entered should the manual IP address selection method be chosen.

IP Configuration: This is a configurable field with two choices: *Automatic* and *Manual*. It impacts how the Model 5512A obtains the IP address that is used for accessing the Model 5512A's management web server and associated menu webpages. This setting has no impact on how the Model 5512A obtains its Primary + Control and Secondary IP addresses that are associated with the ST 2110-related Ethernet interfaces.

Selecting *Automatic* will cause the Model 5512A to use DHCP or IPv4 link-local to establish the IP address for accessing the Model 5512A's management interface. With this setting, upon establishing a link to the Model 5512A's management RJ45 jack the DHCP protocol will request an IP address and related parameters. If obtaining an IP address by way of a DHCP server is not successful, the IPv4 link-local protocol will be used. If the established IP address has the format of 169.254.x.x then it was assigned using the IPv4 link-local.

Even if the management IP address was established using link-local the DHCP protocol will stay active. The Model 5512A's firmware will continue to check for the presence of a DHCP server. If one becomes available then an IP address will be requested and, when obtained, will automatically be used, replacing the IP address that was previously established by link-local.

The *Manual* setting allows the desired IP address and related parameters for the management interface to be manually entered. This can be useful when a fixed addressing scheme has been established. In this way, a "static" IP address can be entered along with the other important network parameters.

When selected for *Automatic*, the fields for Manual IP Address, Manual Subnet Mask, and Manual Gateway will be "grayed out" (will have a gray background) to indicate that their values cannot be manually changed. In this condition, they are display-only. Changing between Automatic and

Manual and vice-versa will not impact the values stored in the Manual IP Address, Manual Subnet Mask, and Manual Gateway fields. Note that the front-panel display and associated pushbutton switches can also be used to revise the Model 5512A's management IP address configuration.

Note that to minimize the chance of losing access to the Model 5512A's management web server, restoring the unit's factory defaults will not change the currently selected management IP configuration choice.

Manual IP Address: This field is grayed out and will not show any text when the IP address configuration mode is selected for *Automatic*. When the IP address is selected for *Manual*, this field will show the IP address that is stored in the Model 5512A. This is the IP address that is currently being used, or will be used at the time of the next Ethernet management connection reboot. It is the IP address that allows access to the Model 5512A's management web server and associated menu webpages. It has nothing to do the IP addresses associated with the ST 2110 primary and control and secondary interfaces.

The manual IP address can be modified as desired to meet the requirements of the application. After entering an IP address using the standard dot-decimal notation (four octets separated by dots), the **Submit** button must be pressed for the changes to be stored. Restoring the Model 5512A's default values will not change the stored manual IP address. A system reboot is required for the revised manual IP address to be utilized. Note that the front-panel display and associated pushbutton switches can also be used to revise the Model 5512A's manual IP address.

Manual Subnet Mask: This field is grayed out when the IP configuration mode is selected for *Automatic*. This field will be display-only in this instance and will show an IPv4 subnet mask value in dot-decimal notation (four octets separated by dots) if the current IP address and related network parameters were obtained by way of DHCP. This is the subnet mask that is being used by the unit's management web server. If the IP address configuration mode is selected for *Automatic* and the current IP address was obtained by way of link-local, a subnet mask address of 255.255.0.0 will be shown in this field.

When the IP configuration model is selected for *Manual*, the manual subnet mask field will not be grayed out. In this situation, the stored subnet mask will be shown and can be modified as desired to meet the requirements of the application. The value shown is the subnet mask that is currently in use, or will be used at the time of the next management Ethernet interface reboot. After entering the desired subnet mask value using the standard dot-decimal notation format (four octets separated by dots), the **Submit** button must be pressed for the change to be stored. A system reboot is required for the revised subnet mask value to be utilized. Note that the front-panel display and associated pushbutton switches can also be used to revise the Model 5512A's management subnet mask. Restoring the Model 5512A to its default values will not change the stored manual subnet mask value.

Manual Gateway: This field is grayed out when the IP configuration mode is selected for *Automatic*. This field will be display-only in this instance and will show an IPv4 gateway IP address in dot-decimal notation (four octets separated by dots) if the current IP address and related network parameters were obtained by way of DHCP. This is the gateway IP address that is being used by the Model 5512A's management web server.

If the IP configuration mode is selected for *Automatic* and the current IP address was obtained by way of link-local, no gateway IP address will be shown in this field. This is because no gateway IP address is associated with link-local.

When the IP configuration mode is selected for *Manual*, the gateway IP address field will not be grayed out. In this situation, the stored gateway IP address will be shown and can be modified as desired to meet the requirements of the application.

The shown value is the gateway IP address that is currently in use, or will be used at the time of the next management Ethernet interface reboot. After entering a gateway IP address using the standard dot-decimal notation format (four octets separated by dots), the **Submit** button must be pressed for a change to be stored. A system reboot is required for the revised gateway IP address to be utilized. Restoring the Model 5512A's default values will not change the stored gateway IP address value.

Submit: A Submit button is located near the bottom of the Network menu webpage. To save any changes made to the configuration fields requires that the saved **Submit** button be pressed.

Access Menu

Model 5512A-02
Audio Interface

ST-M5512A-02_00149
Identify Device

ST 2110 Analog Inputs Analog Outputs Network **Access** System Log Out

Front Panel Control View/Edit ▾
Submit

Management Login Credentials

User Name guest
New Password
Confirm New Password
Default User Name is 'guest'; default Password is 'guest'.
Submit

[Studio Technologies, Inc.](#)

Front Panel Control

Choices are: *View/Edit* and *View Only*.

A graphics display and five associated pushbutton switches are located on the Model 5512A's front panel. This field allows the action of the pushbutton switches to be selected between two choices. When *View/Edit* is selected, the buttons can be used to select what is shown on the display as well as allowing several configuration choices to be changed. When *View Only* is selected, the pushbutton switches will only allow selection of what information is to be shown. The buttons will not allow any configuration changes to be made. Refer to Appendix C for a detailed list of the front-panel menus.

Submit: A Submit button is located below the Front Panel Control selection field. This button must be pressed to save a change made to the Front Panel Control configuration.

Management Login Credentials

As a security method, a user name and password must be entered before the configuration webpages can be accessed. These values can be changed as desired.

The Model 5512A's access security method is in no way rigorous. The user name and password are sent to and received from the Model 5512A as plain text. They are also stored within the Model 5512A as plain text. There is no security method or encryption associated with these fields. Anyone "snooping" on the LAN that is transporting Model 5512A management data will see all values in plain text! The user name and password values are intended simply to provide a means of keeping "friendly" or "honest" users from easily changing the configuration of a Model 5512A. If unauthorized access is of concern, it's recommended that an Ethernet connection to the Model 5512A's management RJ45 jack not be present except when access by authorized personnel is desired.

The default user name is **guest** and the default password is **guest**. These are case sensitive. If neither of these default values are changed, they will show in the User Name and Password entry fields on the Login menu webpage. If the default user name and/or default password are changed, neither the user name nor the password will show upon accessing the Login menu webpage.

User Name: In this field, a revised user name can be entered. It must be a minimum of five characters, a maximum of 15 characters, and is case sensitive. All 95 of the printable ASCII characters can be used. These include upper and lower alphabetic characters, numbers, and standard punctuation marks.

New Password: In this field, a revised password can be entered. The password is a minimum of five characters, a maximum of 15 characters, and is case sensitive. All 95 of the printable ASCII characters can be used. These include upper and lower alphabetic characters, numbers, and standard punctuation marks.

Confirm New Password: For a new password to be considered valid it must also be entered in this field.

Submit: A Submit button is located below the field for Confirm New Password. To save a change made to the User Name field and/or New Password field requires that the **Submit** button be pressed.

System Menu

ST-M5512A-02_00149

ST 2110
Analog Inputs
Analog Outputs
Network
Access
System

Serial Number: 00149

Device Name: ST-M5512A-02_00149

Secondary Network Error Indication:

Version Information

	Version	Date
Main MCU Firmware	1.02	22 Apr 2025
FPGA Firmware	1.01	30 Aug 2021
ST 2110 Firmware	1.6.5b59902	---

Restore Default Configuration

Operational Settings:

Management Interface and Access Settings:

System Reboot:

[Studio Technologies, Inc.](#)

Serial Number: This is a display-only field that shows the Model 5512A’s hardware serial number. A 5-digit number, it is assigned at the factory and cannot be changed.

Device Name: This is a display-only field that shows the name assigned to the ST 2110 interface.

Secondary Network Error Indication: Choices are: *Enabled* and *Disabled*.

LED indicators on the Model 5512A’s front panel can display the status of the ST 2110 secondary interface. This can be useful if the unit’s support for

ST 2022-7 is going to be utilized. As such, when “redundant streams” is active then being able to observe the status of the ST 2110 secondary interface will be useful. But when ST 2022-7 is not going to be utilized the LED indicators associated with the ST 2110 secondary interface will always show an error or not connected state. This can be confusing. A configuration choice allows the LEDs associated with the secondary interface to be disabled. When *Disabled* is selected, the LEDs will not be active and will never light. When *Enabled* is selected, the LEDs will be active.

Version Information

Five display-only fields show information about the firmware (embedded software) that is currently loaded and operating in this specific Model 5512A.

Main MCU Firmware: Two display-only fields show the version number and release date of the Model 5512A's Main MCU firmware. This is the firmware that runs in the Model 5512A's microcontroller (MCU) integrated circuit. This firmware can be updated using a USB flash drive. Details are provided in the Technical Notes section.

FPGA Firmware: Two display-only fields show the version number and release date of the firmware used by the Model 5512A's programmable logic (FPGA) device. This is the firmware that runs in the Model 5512A's high-speed logic device. This firmware can be updated using a USB flash drive. Details are provided in the Technical Notes section.

ST 2110 Firmware: One display-only field shows the version number of the firmware associated with the ZMAN module that the Model 5512A utilizes for ST 2110 interconnectivity. (There is no associated date.) This version number is assigned by Merging Technologies and can't be changed by Studio Technologies. The firmware for the Model 5512A's ST 2110 interface can be updated by way of an Ethernet connection made to the Primary + Control Ethernet interface. Refer to the Technical Note section for details.

Restore Default Configuration: There are two check boxes associated with the restore default configuration function. Either or both can be selected prior to pressing the associated **Submit** button. Enabling the Operational Settings check box allows all the Model 5512A's configuration settings to be restored to their factory default values with the exception of the management interface and user access settings. The configuration values associated with these two functions will not change.

Enabling the management Interface and Access Setting check box allows the Model 5512A's factory default configuration settings for the IP Address Configuration method, Manual IP Address, Subnet Mask, Gateway IP Address, User Name, and Password to be returned to their factory default values. Refer to Appendix F for a list of these values.

After selecting either or both of the check boxes and pressing the **Submit** button, a confirmation message will appear. If the Operational Settings box has been selected and **Submit** is pressed, the message **Default Operational Settings Restored** will appear. If the Management Interface and Access Settings box has been selected and **Submit** is pressed, the message **Default Network and Access Settings Restored** will appear. If both boxes are selected and **Submit** is pressed, the message **All Default Settings Restored** will appear.

System Reboot: A check box and a reboot button are provided in the System Reboot section of this menu page. This function is provided to allow a user to force the Model 5512A to restart operation. Any changes made to the network configuration and/or user name and password settings will be in effect. Once the Reboot check box has been enabled, pressing the **Reboot** button will cause the Model 5512A to halt current operation and restart ("boot") the unit.

Webpage Inactivity Timer/ Automatic Log Out

Once a web browser has successfully logged into the Model 5512A's menu system an inactivity timer will become active. If no configuration setting has been changed, a webpage refreshed, or a webpage newly accessed for 15 minutes, the user will automatically be logged out. Returning to the menu pages will require the login procedure to be successfully completed.

Menu Text and Links

The following paragraphs provide details on some of the links, buttons, and text that are presented on the Model 5512A's webpages.

Company Name Link: On the bottom of each webpage is a link with the title Studio Technologies, Inc. Clicking on this link will cause the browser to open the home webpage of the Studio Technologies website.

ST 2110 Name: In the upper-right corner of each Model 5512A webpage is the ST 2110 interface's name. This name should be unique to each device in a deployment and would be used as part of the identification and channel routing process. The name can be changed from within the configuration webpages provided by ST 2110 interface.

Identify Device Button: In the upper-right corner of most Model 5512A webpages is a button called Identify Device. Clicking on it will cause a unique lighting sequence to occur using the seven blue SEL LEDs that are located on the Model 5512A's front panel. The *Identify* command will help users ensure that the web server on the desired Model 5512A is being accessed.

Log Out Button: A button called Log Out is located in the upper-right of each Configuration menu webpage. It will cause the Model 5512A's web server to end its active session and log out the user. To again access the menu webpages will require that a user provide a valid user name and password.

Operation

Now that the Model 5512A is installed and configured it's ready for use. There are a number of nuances in the unit's operation. This may make it useful for technical personnel to spend some time reviewing this section.

Upon application of AC mains or DC power, the Model 5512A will go through a power-up sequence. The LED associated with the USB receptacle on the unit's back panel will briefly light green to indicate that it is functioning. The LEDs associated with the Model 5512A's three Ethernet jacks will flash several times as part of the associated Ethernet interface integrated circuit's power-up action. The seven LEDs on the unit's front panel will light in a confirmation sequence. After that has completed the display will then enter its "screen saver" mode which shows the Studio Technologies logo and other menus in a continuous sequence. The operating condition of the Model 5512A as it was at the time of the previous power down will be restored. All configuration settings will be restored and normal unit operation will begin. The pushbutton switches associated with the display functions will become active.

RJ45 LED Indicators

On the Model 5512A's back panel are three RJ45 jacks that are provided for interfacing with the unit's three Gigabit Ethernet (GbE) interfaces. One of the jacks is designated for ST 2110 audio and configuration use, a second for redundant ST 2110 audio, and the third for management functions. The three

RJ45 jacks are labeled PRI+CTRL, SEC, and MGMT. Associated with each jack are two LEDs. One LED is labeled LINK and lights orange when a 1000BASE-T (GbE) Ethernet connection has been established with that specific jack. The LINK LED will not light if a 100 Mb/s or 10 Mb/s Ethernet connection has been made. It will also not light if an Ethernet connection has not been made. The second LED, labeled ACT, will flash green to indicate data activity, responding to Ethernet traffic traveling to and from that specific jack.

Front-Panel Display Page Descriptions

The following sections provide information about the Model 5512A's front-panel menu pages. Additional details can be found in the Model 5512A Configuration section. Refer to Appendix C for the menu structure diagram.

The Access Menu web configuration menu page has a selection called Front Panel Control. When the choice of *View/Edit* is selected, the five front-panel pushbutton switches are, in certain circumstances, able to revise some of the Model 5512A's configuration parameters. An arrow icon will show in the upper-right corner of these pages if a configuration change can be made. If the Front Panel Control configuration is selected for *View Only*, no configuration changes can be made using the pushbutton switches. In this case, a lock icon will show in the upper-right corner of the applicable menu pages.

Row One

For the Model 5512A-01 there are two display-only menu pages associated with the top row which we'll refer to as Row One. For the Model 5512A-02 there are four display-only menu pages. These pages relate to the real-time signal levels of the ST 2110 sender (output) channels and the analog output channels.

ST 2110 Senders - Channels 1-8: This menu page will show, in the form of vertical bar graphs, the levels of ST 2110 sender (output) channels 1-8. The levels are shown in dBFS with a reference mark and text shown at -20 dBFS. (This is the Model 5512A's default ST 2110 sender level.) The letter S will show on the left side of this page to indicate that the menu page represents ST 2110 sender channels.

ST 2110 Senders - Channels 9-16: This menu page will only be present in a Model 5512A-02. It will show the levels of ST 2110 sender (output) channels 9-16.

Analog Outputs - Channels 1-8: This menu page will show, in the form of vertical bar graphs, the levels of analog output channels 1-8. The levels are shown in dBu with a reference mark and text shown at +4 dBu. (This is the Model 5512A's default analog output level.) The letter A will show on the left side of this page to indicate that the menu page represents analog output channels.

Analog Outputs - Channels 9-16: This menu page will only be present in a Model 5512A-02. It will show the levels of analog output channels 9-16.

Row Two

There are two pages associated with row two. They show the current configuration and, by default, allow changes to the sources selected for the ST 2110 sender (output) channels and the analog output channels.

ST 2110 Senders Source Select: This menu page will show the current sender (output) sources, as a group, that are used for the ST 2110 sender (output) channels. It will also allow selection from among three choices: *Analog Input Channels*, *ST 2110 Receiver Channels*, and *1 kHz Tone*. Refer to the block diagram in Appendix B for details.

An arrow icon will show in the upper-right corner of this menu page to indicate that the setting can be changed. If the active method is not the desired one, press the **Enter** pushbutton switch located on the front panel. Use the up and down arrow buttons to select the desired sources. (For clarity, the configuration choice that is currently active will have an asterisk (*) at the end of its title.) Then again press the **Enter** button. The entry will then be stored and the selected sources utilized.

Analog Output Source Select: This menu page will show the current signal sources, as a group, that are used for the analog output channels. It will also allow selection from among three choices: *Analog Input Channels*, *ST 2110 Receiver Channels*, and *1 kHz Tone*. Refer to the block diagram in Appendix B for details.

An arrow icon will show in the upper-right corner of this menu page to indicate that the setting can be changed. If the active method is not the desired one, press the **Enter** pushbutton switch located on the front panel. Use the up and down arrow buttons to select the desired sources. (For clarity, the configuration choice that is currently active will have an asterisk (*) at the end of its name.) Then again press the **Enter** button. The entry will then be stored and the selected sources utilized.

Row Three

Row three has a total of seven menu pages. The provided information relates to ST 2110 operation. Some menu pages also allow changes to be made.

ST 2110 Primary and Control Interface IP Configuration:

This menu page allows the display and revision of the method that the Model 5512A's ST 2110 primary and control Ethernet interface uses to obtain its IP address and related parameters. (On the actual menu the abbreviation P+C is used in place of the words primary and control.) The choices are *Automatic* and *Manual*. This setting has no impact on how the Model 5512A obtains IP addresses for its ST 2110 secondary and management interfaces.

If the active configuration method is not the desired one, press the **Enter** pushbutton switch located on the front panel. Use the left and right arrow buttons to select the desired method. Then again press the **Enter** button. The entry will be stored. To cause the primary and control interface to use the new setting requires the ST 2110 interface or the entire unit to be rebooted (restarted). These can be performed by using other front-panel menu pages or by power cycling the unit. (Power cycling means to restart the unit by first removing and then re-applying AC mains or DC power.)

Selecting *Automatic* will cause the ST 2110 primary and control Ethernet interface to use DHCP or, if DHCP is not available, the IPv4 link-local protocol to establish the IP address. (An IP address that has the format of 169.254.x.x is one that was assigned using the IPv4 link-local protocol.) Even if the IP address was established using link-local, the DHCP protocol will remain active. In this case, the ST 2110 primary and control interface will continue to check for the presence of a DHCP server. If one becomes

available, an IP address will be requested and, when obtained, will automatically replace the ST 2110 primary and control IP address that was previously established by way of link-local.

The *Manual* setting allows the ST 2110 primary and control Ethernet interface's IP address and related parameters to be manually entered. This can be useful when a fixed or static addressing scheme has been established. In this way, a designated IP address, along with the other necessary network parameters, can be entered. To cause the ST 2110's primary and control Ethernet interface to use a revised manually entered IP address configuration method requires that the ST 2110 interface be rebooted (restarted) or the entire unit rebooted. This can be performed using the ST 2110 reboot front-panel menu page, using the reboot device front-panel menu page, or by power cycling (restarting) the Model 5512A.

ST 2110 Primary and Control IP Address: This menu page shows the IP address associated with the ST 2110 primary and control interface. (On the actual menu the abbreviation P+C is used in place of the words primary and control.) This address has nothing to do with the IP addresses utilized by the ST 2110 secondary and management interface ports. The standard dot-decimal notation is used to show the primary IP address. If no Ethernet connection has been made to either RJ45 jack, the text **No Ethernet Link** will show.

Whenever the ST 2110 primary and control interface's IP address configuration is selected for the *Manual* mode, the IP address for the ST 2110 primary and control interface can be modified as desired. (This ability will be indicated by an arrow icon that will be shown in the right side of the display.) To start the process of changing the IP address value, press the **Enter** pushbutton switch on the front panel. An icon with a wrench and screwdriver will be shown to indicate that an edit is in process. Use the up and down arrow pushbutton switches to select the desired IP address value. Once the desired value has been selected, press the **Enter** button to store it.

To instruct the unit use the new ST 2110 primary and control IP address value requires that the ST 2110 interface be rebooted (restarted). This can be

performed using the reboot ST 2110 front-panel menu page. Alternately, rebooting the Model 5512A by means of another front-panel menu or a power cycle of the unit can also be utilized to cause a new ST 2110 primary and control IP address value to be used.

ST 2110 Primary and Control Subnet: This menu page shows the subnet mask value associated with the ST 2110 primary and control Ethernet interface. (On the actual menu the abbreviation P+C is used in place of the words primary and control.) Again, this address has nothing to do with the IP addresses utilized by the ST 2110 secondary and management interface ports. The standard dot-decimal notation is used to show the subnet mask value. If no Ethernet connection has been made to this RJ45 jack, the text **No Ethernet Link** will show.

Whenever the ST 2110 primary and control interface's IP address configuration is selected for the *Manual* mode, the subnet mask value can be modified as desired. (This ability will be indicated by an arrow icon that will be shown in the right side of the display.) To start the process of changing the subnet mask value, press the **Enter** pushbutton switch on the front panel. An icon with a wrench and screwdriver will be shown to indicate that an edit is in process. Use the up and down arrow pushbutton switches to select the desired subnet mask value. Once the desired value has been selected, press the **Enter** button to store it.

To instruct the unit use the new ST 2110 primary and control subnet mask value requires that the ST 2110 interface be rebooted (restarted). This can be performed using the reboot ST 2110 front-panel menu page. Alternately, rebooting the Model 5512A by means of another front-panel menu or a power cycle of the unit can also be utilized to cause a new ST 2110 primary and control subnet mask value to be used.

ST 2110 Secondary IP Address: This display-only menu page shows the IP address associated with the ST 2110 secondary interface. A webpage provided by the ZMAN module, as discussed elsewhere in this guide, can be used to modify the configuration method and/or actual ST 2110 secondary IP address. This IP address has nothing to do with the IP addresses

utilized by the ST 2110 primary and control and management interface ports. The standard dot-decimal notation is used to show the IP address. If no Ethernet connection has been made to the SEC RJ45 jack then, text **No Ethernet Link** will show.

ST 2110 PTP Status: This menu page shows the status of the timing that is actively being used by the Model 5512A's ST 2110 interface. Timing is typically provided by an external PTP v2 server, although the Model 5512A is capable of providing the source of timing for an implementation. From this menu, pressing the **Enter** button, then the up and down arrow buttons will allow key PTP timing parameters to be shown. These include the primary and control timing status, the secondary timing status, the grandmaster ID (GMID), and the offset from the grandmaster in nanoseconds.

ST 2110 Firmware Version: This menu page shows the version number of the firmware that's stored in and is being utilized by the ZMAN module that the Model 5512A uses for implementing the unit's ST 2110 capability. It is incorporated into the ZMAN firmware file (with the extension of .zoem) that is released by Studio Technologies specifically for the Model 5512A. As noted previously, this firmware, part of the Merging ZMAN module's product firmware, can be updated by way of an Ethernet connection using a standard web browser.

Reboot ST 2110: This menu page allows the Model 5512A's ST 2110 interface to be rebooted (restarted). This can be useful to force the Model 5512A to utilize revised ST 2110 interface configuration changes. Technically, it will also cause the ZMAN interface module to reboot. If an arrow icon shows in the upper-right corner of this menu a reboot is possible. To start the process of rebooting the ST 2110 interface, press the **Enter** pushbutton on the unit's front panel. This will lead to a confirmation page being shown. Use the left and right arrow pushbutton switches to select the desired action. The choices are to cancel or to confirm. Press the **Enter** pushbutton switch to select the highlighted action. The Model 5512A will then immediately commence the selected action.

After performing an ST 2110 interface reboot (restart), a period of two to four minutes may be required for the Model 5512A's operation to fully restore. During

this process, the management Ethernet port will briefly disconnect and then reconnect.

Row Four

Row four has four front-panel menu pages that involve the Model 5512A's management IP address and related parameters. One menu page is display-only and the other three, in some cases, will allow changes to be made.

Current Management IP Address: This display-only menu page will show the IP address associated with the Model 5512A's internal management web server. This is the IP address that's associated with the connection made to the Model 5512A's management RJ45 jack which is located on the back panel. This address can be assigned automatically using the DHCP protocol or, if a DHCP server is not available, using the IPv4 link-local protocol. (If the IP address shown is in the format of 169.254.x.x it was assigned using IPv4 link-local.) The management IP address can also be assigned with a manual (fixed or static) IP address. If no Ethernet connection has been made to the MGMT RJ45 jack the text **No Ethernet Link** will be shown.

Management IP Configuration: This menu page allows the display and revision of the method that the Model 5512A uses to obtain its management IP address and related parameters. The choices are *Automatic* and *Manual*. The selected configuration impacts how the Model 5512A obtains the IP address that is used for accessing the management web server and associated menu webpages. This setting has no impact on how the Model 5512A obtains IP addresses for the ST 2110 primary and ST 2110 secondary Ethernet interfaces.

An arrow icon will show in the upper-right corner of this menu page if the setting can be changed. If the active method is not the desired one, press the **Enter** pushbutton switch located on the front panel. Use the left and right arrow buttons to select the desired method. (For clarity, the configuration choice that is currently active will have an asterisk (*) at the end of its name.) Then again press the **Enter** button. The entry will be stored. To cause the Model 5512A to use a new setting requires that the unit be rebooted (restarted). This can be performed using another front-panel menu page, a selection in one of the management webpages, or by power cycling the unit.

Selecting the *Automatic* setting causes the Model 5512A to use DHCP or, if DHCP is not available, the IPv4 link-local protocol to establish the IP address for the management port. Even if the IP address was established using link-local the DHCP protocol will remain active. In this case, approximately every 30 seconds the Model 5512A's firmware will check for the presence of a DHCP server. If one becomes available then an IP address will be requested and, when obtained, it will automatically replace the IP address that was previously established by link-local.

The *Manual* setting allows the desired IP address and related parameters to be manually entered. This can be useful when a fixed or static addressing scheme has been established. In this way, a designated IP address can be entered along with the other necessary network parameters.

Note that to minimize the chance of losing access to the management web server, restoring the Model 5512A's default configuration values will not change the currently selected IP address configuration choice.

Manual Management IP Address: This menu page shows the stored IP address associated with the management interface and corresponding web server. This address has nothing to do with the IP address utilized by the ST 2110 primary and control and ST 2110 secondary Ethernet interfaces. It will be utilized only when the manual mode has been selected for the management IP address configuration. When the IP address configuration has been selected for *Automatic*, this field cannot be changed and a lock icon will show in the upper-right corner of the display.

Whenever the IP address configuration is selected for *Manual*, the manual IP address can be modified as desired. This will be indicated by an arrow icon that will show in the upper-right corner of the display. To start the process of changing the manual management IP address, press the **Enter** pushbutton switch on the front panel. An icon with a wrench and screwdriver will show to indicate that an edit is in process. Use the left and right arrow pushbutton switches to select which specific digit of the IP address number is to be modified. Press the up and down arrow pushbuttons to select the desired number. The standard dot-decimal notation is used to show and revise the

IP address. Once the desired changes have been made, press the **Enter** button to store them.

To cause the Model 5512A to use a new manual management IP address value requires that the unit be rebooted (restarted). This can be performed using another front-panel menu page, using a function on a management webpage, or by power cycling the unit. Restoring the Model 5512A to its default values will not change the stored manual IP address.

Manual Management Subnet Mask Value: This menu page shows the stored subnet mask value associated with the management interface and corresponding web server. As expected, this value has nothing to do with the subnet mask values utilized by the ST 2110 primary and control and ST 2110 secondary ports. It will be utilized only when the manual mode has been selected for the management IP address configuration. When the IP address configuration has been selected for *Automatic*, this field cannot be changed and a lock icon will show in the upper-right corner of the display.

Whenever the IP address configuration is selected for *Manual*, the manual management subnet mask value can be modified as desired. This will be indicated by an arrow icon that will show in the upper-right corner of the display. To start the process of changing the subnet mask value, press the **Enter** pushbutton switch on the front panel. An icon with a wrench and screwdriver will show to indicate that an edit is in process. Use the up and down arrow pushbutton switches to select the desired subnet mask value. Once the desired value has been selected, press the **Enter** button to store it.

To cause the Model 5512A to use a new manual management subnet mask value requires that the unit be rebooted (restarted). This can be performed using another front-panel menu page, using a function on a management webpage, or by power cycling the unit. Restoring the Model 5512A to its default values will not change the stored subnet mask value.

Row Five

Row five contains six menu pages. Five of the menu pages are display-only and provide information about the Model 5512A, including its ST 2110 device name, the unit's serial number, and the version number of

the main and FPGA firmware (embedded software) that's in use. A sixth menu page allows the system to be rebooted (restarted).

ST 2110 Name: The name of the ST 2110 device is shown on this menu page. This name should be unique to each device in an ST 2110 deployment and is used as part of the channel routing process. The name can be changed from within the webpages provided by the ZMAN module. The text shown on this menu page is the same as is shown in the upper-right corner of each Model 5512A management webpage.

Product Name & Serial Number: This menu page shows the name of the product (**Model 5512A**) and the hardware serial number. This name and serial number (along with the three MAC addresses associated with the Ethernet interfaces) are assigned at the factory and cannot be changed.

Main MCU Firmware Version: This menu page shows the version number of the Model 5512A's Main MCU firmware. This firmware can be updated using a USB flash drive. Update details are provided in the Technical Notes section.

FPGA Firmware Version: This menu page shows the version number of the Model 5512A's FPGA (field-programmable-gate-array) firmware. This firmware can be updated using a USB flash drive. Update details are provided in the Technical Notes section.

ZMAN Temperature: This menu page shows the temperature (in degrees Celsius) as reported by the ZMAN module. This module is used to provide the ST 2110 interface.

Reboot Device: This menu page allows the Model 5512A to be rebooted (restarted). This can be useful to force the Model 5512A to utilize revised ST 2110 and management Ethernet interface configuration changes. It will also cause the ZMAN module to reboot. An arrow icon may show in the upper-right corner of this menu. To start the process of rebooting the Model 5512A, press the **Enter** pushbutton on the unit's front panel. This will lead to a confirmation page being shown. Use the left and right arrow pushbutton switches to select the desired action. The choices are

to cancel or to confirm. Press the **Enter** pushbutton switch to select the highlighted action. The Model 5512A will then immediately commence the selected action.

After performing a system reboot (restart), a period of two to four minutes may be required for Model 5512A operation to fully restore. During this process the management Ethernet port will briefly disconnect and then reconnect.

Screen Saver: A "screen saver" mode will automatically activate two minutes after the last press of one of the five front-panel pushbutton switches or if two minutes have elapsed since one of the menus from rows 2-5 began being shown. The screen saver will not invoke if one of the level metering functions, provided in row 1 of the front-panel menus, is active. When active, the screen saver mode will cause a continuous sequence of five (for the Model 5512A-01) or seven (for the Model 5512A-02) menu pages to show. The sequence of display-only pages consists of the Studio Technologies' logo showing for approximately four seconds, then each of the subsequent menu pages being present for four seconds. The display sequence is continuous, each time moving on to show the next menu page.

When the screen saver mode is active, pressing the **Enter** pushbutton switch on the front panel will cause it to stop and immediately show item one of row four, the current management IP address. To cause the screen saver mode to immediately start, simultaneously press the left and right arrow pushbutton switches on the front panel.

The five menu pages in the Model 5512A-01's screen save mode are:

1. Studio Technologies' company logo graphic.
2. ST 2110 primary and control IP address.
3. Current management IP address.
4. Level meters associated with ST 2110 sender (output) channels 1-8.
5. Level meters associated with analog output channels 1-8.

The seven menu pages in the Model 5512A-02's screen save sequence are:

1. Studio Technologies' company logo graphic.
2. ST 2110 primary and control IP address.
3. Current management IP address.
4. Level meters associated with ST 2110 sender (output) channels 1-8.
5. Level meters associated with ST 2110 sender (output) channels 9-16.
6. Level meters associated with analog output channels 1-8.
7. Level meters associated with analog output channels 9-16.

Details regarding the information provided in each of the screen saver menu pages were documented in previous sections.

Technical Notes

Management IP Address

A management Ethernet interface is associated with the Model 5512A's overall configuration. Using an RJ45 jack, this interface, labeled MGMT, is provided for both factory and installer use. By default, the network parameters for this interface are set to be obtained automatically. In this way, it will attempt to automatically obtain an IP address and associated settings using DHCP. If a DHCP server is not detected, an IP address will automatically be assigned using the link-local protocol in the IPv4 range of 169.254.x.x. The IP address can also be manually configured.

Model 5512A Firmware Update

The major functions implemented in the Model 5512A utilizes an interface circuit board which is named the DFB card. It is linked together inside the unit with a circuit card referred to as the motherboard. The DFB card supports the ST 2110 interface as well as the front-panel menu system and the web-based management menu system.

Three firmware files are utilized in the Model 5512A. They can all be individually field-updated. One firmware file, called the main MCU firmware, is used by the DFB card's microcontroller integrated circuit. A

second firmware file, called the FPGA firmware, is used by the DFB card's field-programmable-gate-array (FPGA) integrated circuit. A third file used by the DFB card supports the ZMAN module which implements the Model 5512A's ST 2110 interface.

The main MCU and FPGA firmware files are updated using a USB flash drive that is plugged into the USB Type-A receptacle labeled Firmware Update. The firmware used by the DFB card for the ZMAN module is updated using a personal computer that is connected, via Ethernet, using the ST 2110's PRI+CTRL RJ45 jack. It's not possible to directly use a USB flash drive for this update process.

It's possible that updated versions of the firmware (embedded software) files that are utilized by the Model 5512A will be released to add features or correct issues. Refer to the Studio Technologies' website for the latest firmware files. Details on the actual update process will be covered in the following paragraphs.

Main MCU and FPGA Firmware Update

The DFB card, used in the Model 5512A, has the ability to load two of its three firmware files into non-volatile memory by way of a standard USB flash drive. A USB host function provides access to update its firmware by way of a USB Type-A receptacle. This receptacle, labeled Firmware Update, is located on the unit's back panel. The names of the two files are **M5512AvXrXX.stm** for the main MCU firmware and **M5512AvXrXX.stf** for the FPGA firmware, where *Xs* are decimal digits that represent the version number.

The update process begins by preparing a USB flash drive. The flash drive doesn't have to be empty (blank) but must be in the personal-computer-standard FAT32 format. The firmware files can be automatically loaded at essentially the same time. On the flash drive's root folder, save the desired new firmware file(s), ensuring that the required name or names are specified. For the main MCU firmware the file name must be **M5512AvXrXX.stm**, for the FPGA firmware the file name must be **M5512AvXrXX.stf**.

Studio Technologies will supply each firmware file inside a .zip archive file. While the firmware file inside of the .zip file will adhere to the required

naming convention, the name of the .zip file itself will be slightly different. For example, a file named **M5512Av1r06MCU.zip** would indicate that version 1.06 of the main MCU firmware (**M5512Av1r06.stm**) is contained within this .zip file. Note that the same main MCU firmware file is utilized for the -01 and -02 versions.

Once the USB flash drive has been prepared it can be used to update the DFB card. To begin the update process, insert the prepared flash drive into the USB receptacle that is labeled Firmware Update, then the Model 5512A must be powered off and again powered on. At this point, the file(s) will be automatically loaded. Once completed, the USB flash drive can then be removed. The precise steps required will be highlighted in the next paragraphs.

To install one or both of the firmware files in the DFB card follow these steps:

1. Remove power from the Model 5512A. This will entail either removing the AC mains power connector or removing the external source of 12 volts DC. (Both must be disconnected if dual powering has been implemented.)
2. Locate the USB Type-A receptacle on the Model 5512A's back panel that is labeled Firmware Update. Directly adjacent to this USB receptacle is a small hole that provides visual access to a green LED indicator.
3. Insert the prepared USB flash drive into the USB Type-A receptacle.
4. Apply power to the Model 5512A. Power can be provided by connecting AC mains or a source of 12 volts DC.
5. After a few seconds, the DFB card will run a "boot loader" program that will automatically load and save the new firmware files that are present on the USB flash drive. The time required for the update process can range from approximately 15 seconds to approximately 45 seconds, depending on which of the files are going to be updated. While the files are being loaded, the green LED, located adjacent to the USB receptacle, will flash slowly. Once the entire loading process has completed, the DFB card will restart using the newly saved firmware.

6. At this time, the DFB card should be functioning with the newly loaded firmware and the USB flash drive can be removed. To be conservative, remove the power source first, then remove the USB flash drive.
7. Apply power to the Model 5512A. Power can be provided by connecting AC mains or a source of 12 volts DC. At this point, it's a good idea to confirm that the desired firmware versions have been loaded into the Model 5512A. This will help to ensure that the unit is operating as expected. To observe the version numbers of the loaded firmware, simply view the unit's front-panel display pages.

Note that upon power being applied to the Model 5512A, if a connected USB flash drive doesn't have one or both files with the required names in its root folder no harm will occur. Upon power up the green LED, located adjacent to the USB receptacle, will flash on and off rapidly for a few seconds to indicate that a valid file has not been found. After this warning, operation using the unit's existing firmware will begin.

ST 2110 Firmware Update

As previously discussed, the Model 5512A implements ST 2110 connectivity using Merging Technologies' ZMAN module which is installed in the unit's DFB card. The Model 5512A's front-panel display can be used to view the version number of the firmware that resides in the ZMAN module. A webpage provided by the ZMAN module can also be used to determine the version of the firmware. The latest Model 5512A ST 2110 firmware file, with an extension of .zoem, is always available on the Studio Technologies' website.

The firmware (embedded software) residing in the ZMAN module is updated by way of an Ethernet connection that links the DFB card to a personal computer. Webpages that are "served" by the ZMAN module are accessed by the personal computer's browser and are used to execute the update process. The following sections detail the process involved in updating the ZMAN firmware.

1. Begin the update process by downloading the latest Model 5512A ZMAN firmware from the Studio Technologies' website (studio-tech.com). The file on the website will be in the form of a .zip file that contains both the actual ZMAN firmware file (.zoem extension) and a release notes file (.txt extension). The downloaded .zip file should be stored on the personal computer's disk and the actual firmware file should be extracted and stored in a location (disk folder) that allows easy access. The downloaded .zip and extracted firmware files can also be stored on a USB flash drive if the files need to be moved from a computer outside of a firewall to one that has access to the Model 5512A. The firmware will be in the format of **M5512A-NNvXrXX.zoem** where the *NNs* are either 01 for a Model 5512A-01 or 02 for a Model 5512A-02. *Xs* represent the actual version number. As an example, a file with a name of **M5512A-03v1r12.zoem** would support a Model 5512A-03 with a version number of 1.12.
2. Use the personal computer to access the Model 5512A's PRI+CTRL interface. The IP address of this interface can be viewed from the front-panel menu. It's part of the screen saver routine as well as being accessible using the pushbutton switches. Refer to Appendix C for a detailed view of the menu system.
3. Using a standard web browser running on the personal computer, enter the ST 2110 PRI+CTRL interface's IP address into the command line. This will cause a webpage to be "served" by the ZMAN module. We refer to this as the "landing page," an example of which is shown in Appendix D, Figure 1.
4. Using the personal computer's mouse, select the **Info** choice on the bottom of the landing page. This will take the browser to the info page, an example of which is shown in Appendix D, Figure 2. The info page will show several general ZMAN parameters, including the temperature, serial number, and firmware version. It will also provide two choices, including one that says *Firmware Update*.
5. Use the personal computer's mouse to select the firmware update command. The file selection webpage will appear. Refer to Appendix D, Figure 3 for an example of this webpage.
6. Using the personal computer's mouse, select the **Select File** button and choose the desired ZMAN file (.zoem) that was previously downloaded and stored on the personal computer. Once a file has been selected, a slightly changed download page will again be shown. Refer to Appendix D, Figure 4 for an example of what you might observe.
7. Using the personal computer's mouse, select the **Update** button and the updating process will begin. The process will begin by uploading the selected file from the person computer to the ZMAN module. The actual upload process will take approximately 30 seconds after which the menu will show the text **Uploading: 100%**. Refer to Appendix D, Figure 5 for an example of the webpage. This is part of the process so just observe the webpage at this stage.
8. The process will automatically continue, preparing the now-uploaded file and loading it into the required location on ZMAN's memory. This will take approximately five additional minutes. During this time, please do not disturb the personal computer browser or Model 5512A. Once the update process has completed, a new webpage will be shown, offering an opportunity to reboot the module. Refer to Appendix D, Figure 6 for an example.
9. On the reboot page, use the personal computer's mouse to click on **Reboot Device** to begin the ZMAN module's reboot process. Refer to Appendix D, Figure 7 for an example of the webpage.
10. Rebooting will take about one and a half minutes. When completed, the Model 5512A and associated ZMAN module will be operating under the new firmware. The info webpage will again appear. Refer to Appendix D, Figure 8 for an example of this webpage.
11. Observe the info webpage and confirm that the ZMAN module is running the desired firmware version. If it is not, review the update steps and execute the update process again.

Restoring Default Values

A command in the System webpage provided by the Model 5512A's web server allows most of the configuration settings to be restored to their factory default values. This can be useful but must be used with caution. Any customization made to the Model 5512A's configuration will be lost. This can be offset in a positive way by returning the Model 5512A to a known configuration, a point that might aid in troubleshooting an issue. Refer to Appendix F for a list of the default values.

Lost User Name and/or Password

As is covered in detail in other sections, gaining access to the Model 5512A's configuration menu webpages requires entering the correct user name and password. If the default entries, both of which are **guest**, are stored for use they will show on the Login menu webpage. Pressing the **Login** button on that webpage will access the Home configuration webpage. If either or both the user name and the password have been configured to be something other than **guest** (the default), nothing will show in the fields associated with the Login menu webpage.

If knowledge of the stored user name and/or password is "lost," the Model 5512A includes a "back door" to allow access. As a security measure, physical access to the unit is required to utilize that access method; there is no means to access the unit via an Ethernet interface without knowledge of the user name and password. The exact process of accessing the Model 5512A's configuration webpages without knowledge of the user name and/or password is detailed in Appendix G.

Specifications

Versions Available:

Model 5512A-01: 8 line-level analog inputs and 8 line-level analog outputs (Order Code: M5512A-01)

Model 5512A-02: 16 line-level analog inputs and 16 line-level analog outputs (Order Code: M5512A-02)

Network Audio Technology:

Type: SMPTE ST 2110-10:2017 and ST 2110-30:2017

Supports Conformance Levels:

A: 48 kHz streams with 1-8 audio channels at packet times of 1 ms

B: 48 kHz streams with 1-8 audio channels at packet times of 125 us

C: 48 kHz streams with 1-64 audio channels at packet times of 125 us

AX: 96 kHz streams with 1-4 audio channels at packet times of 1 ms

BX: 96 kHz streams with 1-8 audio channels at packet times of 125 us

CX: 96 kHz streams with 1-32 audio channels at packet times of 125 us

AMWA NMOS Support: IS-04 Discover & Registration (“Discovery”) and IS-05 Device Connection Management (“Routing”)

Redundant Streams: compliant with Level B, SMPTE ST 2022-7:2013 Seamless Protection Switching (8-channel stream at 48 kHz sampling rate, packet time 125 us)

Synchronization: per SMPTE ST 2110-10, Precision Time Protocol (PTP) IEEE® 1588-2008 Version 2; supported profile IEEE 1588:2008

Compatibility: JT-NM TR-1001 (System Environment and Device Behavior)

Discovery, Control, and Connection Management: includes web user interface, NMOS, Merging Technologies’ ANEMAN Audio Network Manager, and JSON API

Audio Performance and Transport: digital

Audio Type: pulse-code modulation (PCM)

Sampling Rate: 48 or 96 kHz

Bit Depth: 24

Number of Receiver (Input) Channels – Model 5512A-01: 32

Number of Sender (Output) Channels – Model 5512A-01: 32

Number of Receiver (Input) Channels – Model 5512A-02: 64

Number of Sender (Output) Channels – Model 5512A-02: 64

Remote Control of Audio Input Parameters:

webpages provided by internal web server

Network Interfaces:

Qty: 3; ST 2110 Primary + Control (PRI+CTRL), ST 2110 Secondary (SEC), and Management (MGMT)

Type: 1000BASE-T (Gigabit Ethernet (GbE)) per IEEE 802.3ab

NIC Status LEDs: one link and one activity for each Ethernet interface

Analog Inputs:

Type: electronically balanced, capacitor coupled, intended for connection to balanced (differential) or unbalanced signal sources

Impedance: 20 k ohms

Nominal Level: +4 dBu, reference –20 dBFS, adjustable ±20 dB in 0.1-dB steps

Maximum Level: +24 dBu, results in digital output level of 0 dBFS

Dynamic Range: 120 dB, A-weighted

Distortion (THD+N): <0.0004% (–108 dB), ref 1 kHz, +23 dBu input/–1 dBFS output

Frequency Response: ±0.2 dB, 14 Hz to 20 kHz

Analog Outputs:

Type: electronically balanced, capacitor coupled, intended to drive balanced or unbalanced loads of 2 k ohms or greater

Source Impedance: 200 ohms

Nominal Level: +4 dBu, reference –20 dBFS, adjustable ±20 dB in 0.1-dB steps

Maximum Level: +24 dBu

Dynamic Range: >119 dB, A-weighted

Distortion (THD+N): <0.001% (–101 dB), reference 1 kHz, –1 dBFS input/+23 dBu output

Frequency Response: ±0.1 dB, 6 Hz to 20 kHz

1 kHz Tone Output:

Analog: 1 kHz sine-wave at +4 dBu, nominal, adjustable ±20 dB in 0.1-dB steps

ST 2110 (Digital): sine-wave at –20 dBFS, fixed

Front-Panel Display: OLED

Software Updating: USB flash drive supports updating of main MCU and FPGA firmware (embedded software); webpages via PRI+CTRL interface used to update ZMAN module used for ST 2110

Power Sources:

AC Mains: 100 to 240 V, 50/60 Hz, 20 W maximum

DC: 10 to 16 V, 1.2 A max at 10 V; 1.0 A max at 12 V

Connectors:

Analog Inputs and Analog Outputs: 2 (Model 5512A-01), 4 (Model 5512A-02), 25-pin female D-subminiature (DB-25F), AES59-2012-compliant

Ethernet: 3, RJ45 jack

USB: Type-A receptacle (used only for updating firmware)

AC Mains: 3-blade, IEC 320 C14-compatible (mates with IEC 320 C13)

DC: 4-pin male XLR (pin 1 negative, pin 4 positive)

Environmental:

Operating Temperature: 0 to 45 degrees C (32 to 122 degrees F)

Storage Temperature: -40 to 70 degrees C (-40 to 158 degrees F)

Humidity: 5 to 95%, non-condensing

Altitude: not characterized

Dimensions – Overall:

19.0 inches wide (48.3 cm)

1.72 inches high (4.4 cm)

7.8 inches deep (19.8 cm); 8.3 inches (21.1 cm) overall

Mounting: one space (1U) in a standard 19-inch rack

Weight: 3.5 pounds (1.6 kg)

Specifications and information contained in this User Guide subject to change without notice.

Appendix A – Connection Pin-Out Charts

Notes:

- 1) Connector type is 25-pin female D-subminiature (DB-25F). Installer must provide male (DB-25M). Connectors use 4-40 UNC threaded inserts for locking with mating plugs.
- 2) Wiring schemes follow AES59-2012 convention. Standard TASCAM-type wiring harnesses are typically compatible (locking hardware requires 4-40 UNC screw threads).

Model 5512A-01 Analog Inputs and Analog Outputs

Connections for Analog Input Channels 1-8

Channel	High (+)	Low (-)	Shield
1	24	12	25
2	10	23	11
3	21	9	22
4	7	20	8
5	18	6	19
6	4	17	5
7	15	3	16
8	1	14	2

Connections for Analog Output Channels 1-8

Channel	High (+)	Low (-)	Shield
9	24	12	25
10	10	23	11
11	21	9	22
12	7	20	8
13	18	6	19
14	4	17	5
15	15	3	16
16	1	14	2

Model 5512A-02 Analog Inputs and Analog Outputs

Connections for Analog Input Channels 1-8

Channel	High (+)	Low (-)	Shield
1	24	12	25
2	10	23	11
3	21	9	22
4	7	20	8
5	18	6	19
6	4	17	5
7	15	3	16
8	1	14	2

Connections for Analog Output Channels 1-8

Channel	High (+)	Low (-)	Shield
9	24	12	25
10	10	23	11
11	21	9	22
12	7	20	8
13	18	6	19
14	4	17	5
15	15	3	16
16	1	14	2

Connections for Analog Input Channels 9-16

Channel	High (+)	Low (-)	Shield
1	24	12	25
2	10	23	11
3	21	9	22
4	7	20	8
5	18	6	19
6	4	17	5
7	15	3	16
8	1	14	2

Connections for Analog Output Channels 9-16

Channel	High (+)	Low (-)	Shield
9	24	12	25
10	10	23	11
11	21	9	22
12	7	20	8
13	18	6	19
14	4	17	5
15	15	3	16
16	1	14	2

Appendix B – Source Selection Overview

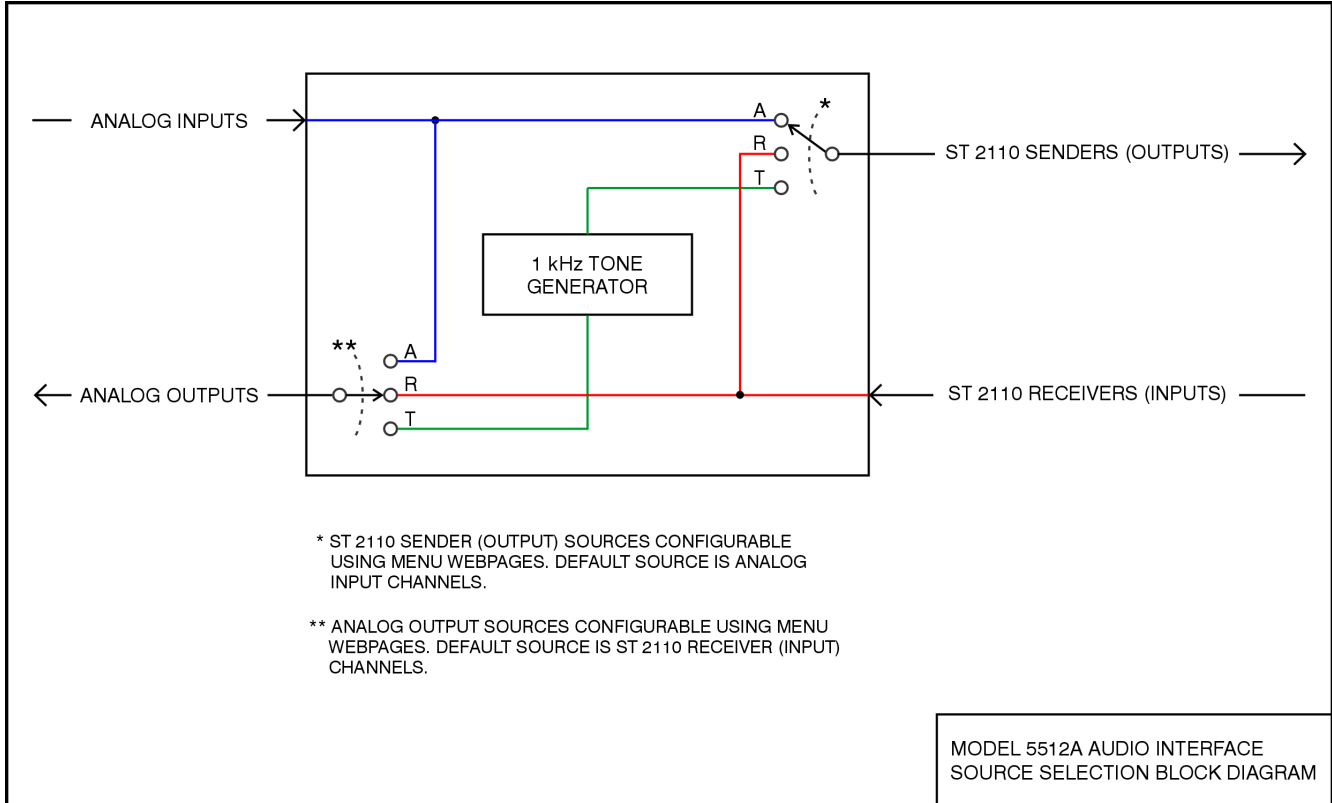

Appendix C – Model 5512A Front-Panel Menu Structure

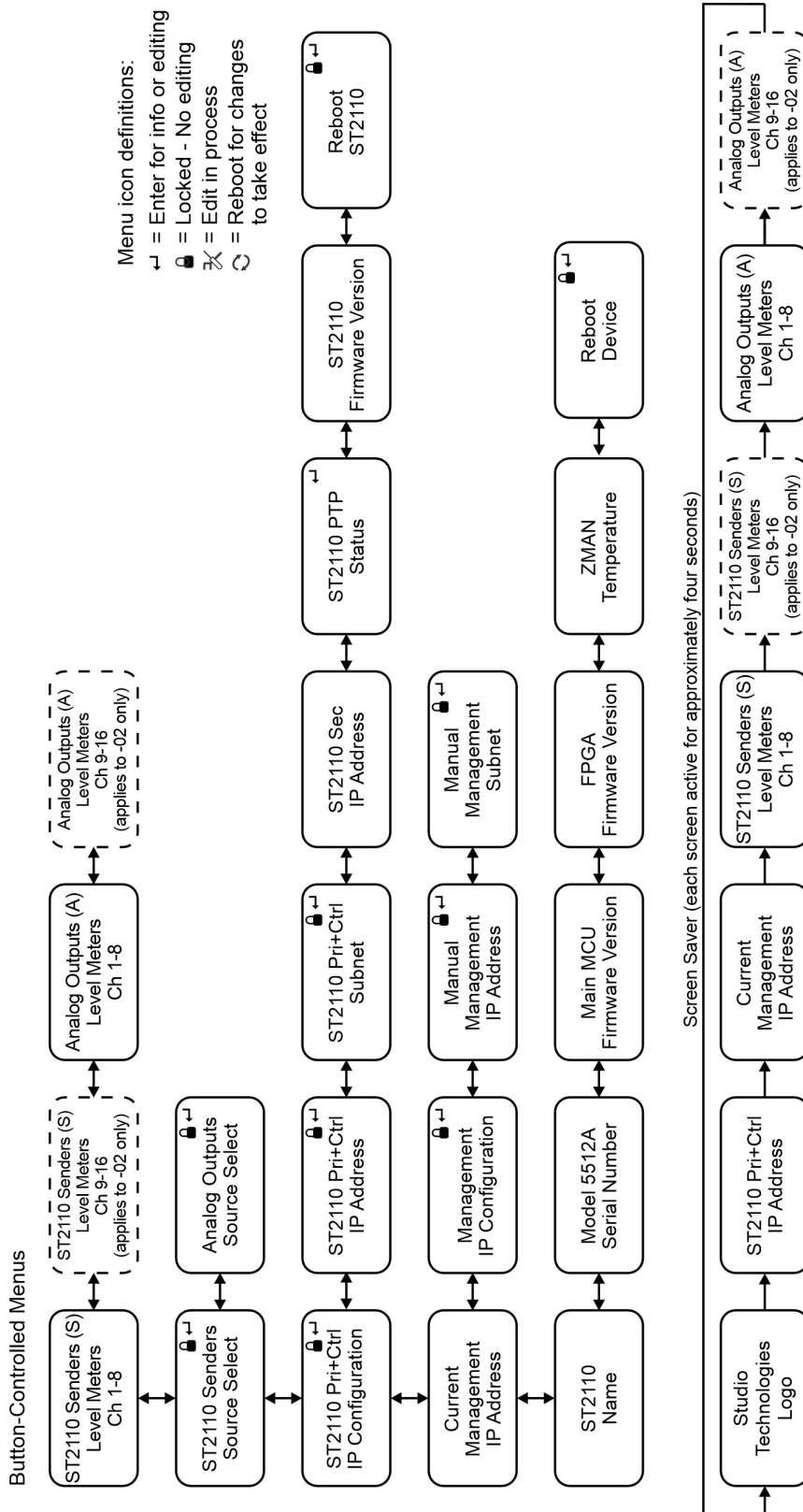

1. For menu rows 2-5, screen saver automatically activates two minutes after last button press.
2. Press Left and Right buttons simultaneously to immediately enter screen saver mode.
3. Pressing Enter while screen saver is active goes to Current Management IP Address page.

Appendix D – ST 2110 (ZMAN) Firmware Update Screens



Figure 1.

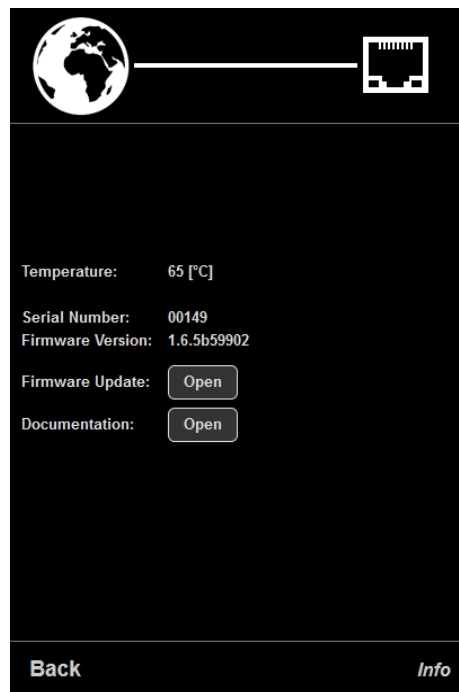

Figure 2.

Appendix D – ST 2110 (ZMAN) Firmware Update Screens, continued

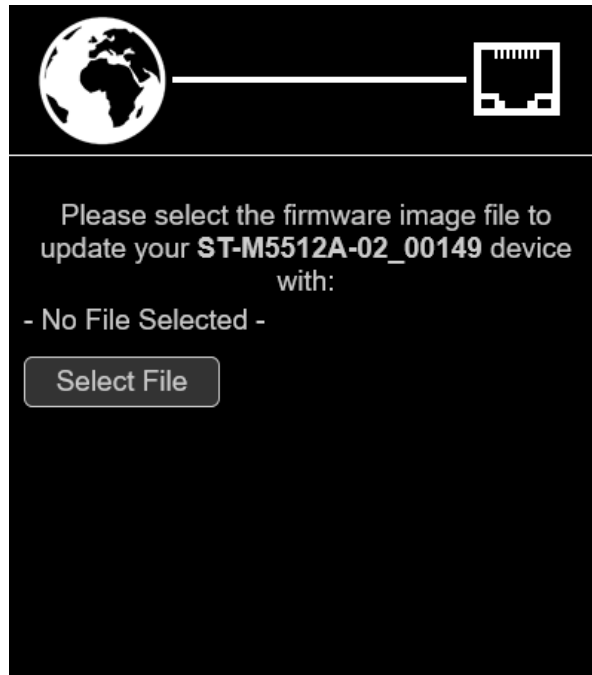

Figure 3.

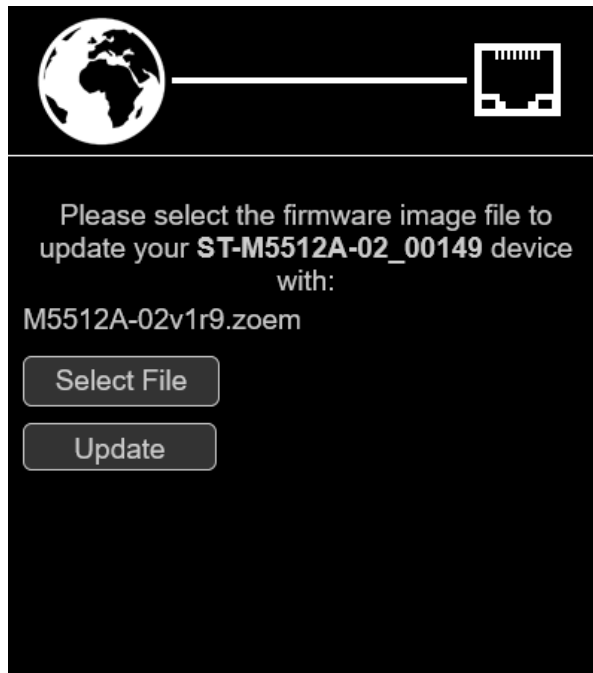

Figure 4.

Appendix D – ST 2110 (ZMAN) Firmware Update Screens, continued

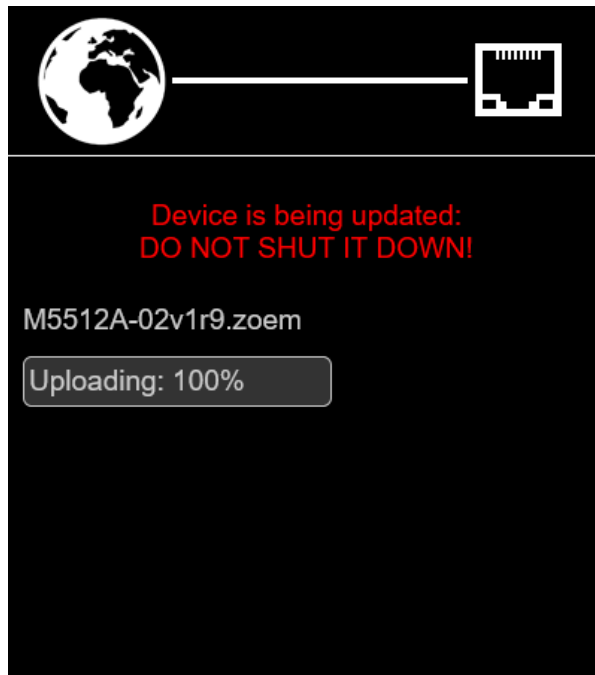

Figure 5.

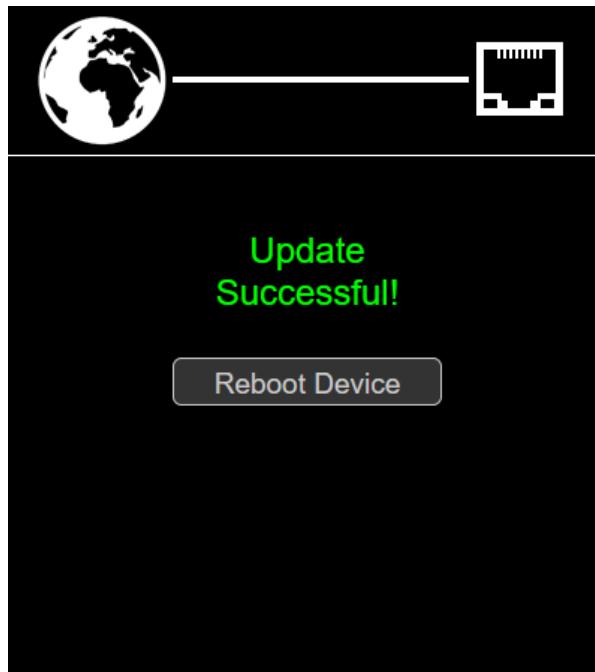

Figure 6.

Appendix D – ST 2110 (ZMAN) Firmware Update Screens, continued

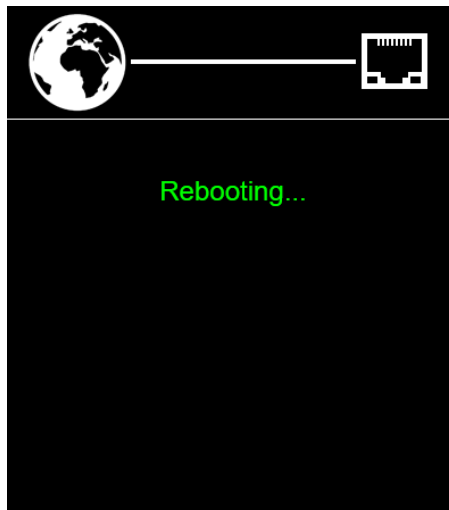

Figure 7.

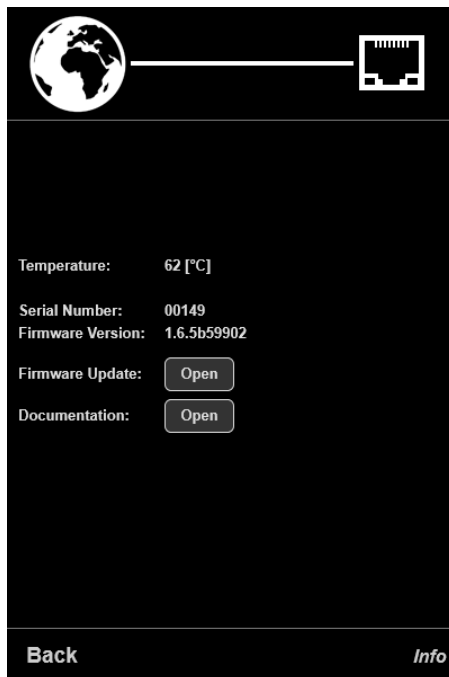

Figure 8.

Appendix E – Advanced ST 2110 (ZMAN) General Settings Screen

RAVENNA
AES67 now!

Vendor **Studio Technologies, Inc.**
Product **M5512A-02**
Serial **00149**
Identify Me

STUDIO TECHNOLOGIES INC.

ST-M5512A-02_00149 local

General settings | PTP | ASIO Clock | Session sources | Session sinks | Ins/Outs | I/O Router | Statistics | NMOS | System

Device Name
ST-M5512A-02_00149
This is the unique zeroconf device name. Other devices see this device name.

Location

Audio Configuration
Sample rate: 48 kHz
Frame size (@1FS): 48 smpl AES67(1ms)

Session Sinks Global
Safety Playout Delay (@1FS): 0
SSM (requires IGMP v3)

Network
Multi-Interface mode
Note: must be checked for ST2022-7 support.

Interface 1
Link: Up
Name: Primary + Control
Type: DHCP
Address: 192.168.1.118
Netmask: 255.255.255.0
Gateway: 192.168.1.1 Use as Primary Gateway
DNS: 192.168.1.178

Interface 2
Link: Down
Name: Secondary
Mode: Media Only

Appendix F – Default Configuration Values

Analog Inputs:

Gain: 0.0 dB

ST 2110 Session Source: Analog Inputs

Analog Outputs:

Gain: 0.0 dB

Source: ST 2110 Receivers

Network - Management Interface:

IP Configuration: Automatic

Manual IP Address: 192.168.1.12

Manual Subnet Mask: 255.255.255.0

Manual Gateway: 192.168.1.1

Access:

Front Panel Control: View/Edit

User Name: guest

Password: guest

System:

Secondary Network Error Indication: Enabled

Appendix G – Accessing the Unit when User Name and/or Password are Not Known

Follow this procedure to access the management menu webpages if the user name and/or password are not known.



1. Remove power from the Model 5512A.
2. Press and hold the left arrow and Enter buttons.
3. While continuing to hold the two buttons apply AC Mains or 12 volts DC power.
4. Continue to hold the two buttons and allow the Model 5512A to start. The Status LEDs on the front panel will first light green then light red in their start-up sequence.
5. Once the Status LEDs have completed their start-up sequence release the two buttons.
6. Use a web browser to access the Model 5512A's management menu webpages. The management port's IP address to use is shown in the current management IP address page on the front-panel display.
7. From the Home webpage select the Login menu webpage tab. Leave the user name and password fields empty and click the Log In button. This will allow access to the management menu selections. At this point your web browser should show the Model 5512A's ST 2110 webpage.
8. Navigate to the Access menu. From this webpage you will be able to view the stored user name. You will not be able to view the previously saved password. Enter and confirm a new password. Henceforth, to access the Model 5512A's management menu will require the use of the stored user name and password.