

# **Model 5418 Mic/Line Interface**

## **User Guide**

Issue 4, April 2026

**This User Guide is applicable for serial numbers:**

M5418-00151 and later with

Main MCU Firmware (.bin) version 3.07 and later

Secondary MCU Firmware

S/N 0363-later (.sts) version 2.01 and later

S/N 00151-00362 (.bin) version 1.01 and later

FPGA Firmware (.bit) version 1.03 and later

Dante Firmware (.dnt) version 5.1.0 (Brooklyn 3 v4.3.1.8) and later

STcontroller

Version 4.04.04 and later (Windows)

Version 4.04.02 and later (MacOS)

**Copyright © 2026 by Studio Technologies, Inc., All rights reserved**  
studio-tech.com

This page intentionally left blank.

## Table of Contents

Revision History.....	4
Introduction.....	5
Installation .....	9
Dante Configuration.....	12
Model 5418 Configuration .....	14
Operation.....	29
STcontroller Support.....	35
Technical Notes .....	36
Specifications .....	40
Appendix A – Network Configuration Examples .....	42
Appendix B – Connection Pin-Out Charts .....	44
Appendix C – Default Dante Channel Names .....	45
Appendix D – Source Selection Overview.....	46
Appendix E – Front-Panel Menu Structure.....	47
Appendix F – Default Configuration Values.....	48
Appendix G – Accessing the Unit when User Name and/or Password are Not Known ..	49

# Revision History

## **Issue 4, April 2026:**

- Documents factory default change to *Redundant Dante*.

## **Issue 3, August 2025:**

- Documents Firmware by serial numbers.
- Miscellaneous changes and corrections.

## **Issue 2, December 2022:**

- Documents revised web menus.

## **Issue 1, November 2022:**

- Initial release.

## Introduction

The Model 5418 Mic/Line Interface provides a simple yet high-performance means of interfacing analog signals with applications that utilize Dante® audio-over-Ethernet media networking technology. Eight analog microphone- or line-level sources can be connected to the unit and then output in the digital domain by way of a Dante interface. Eight digital audio signals, which arrive by way of Dante, are converted to analog and then output as balanced line-level signals. Configuration choices also allow other audio signals to be selected as the sources for the analog output channels. A monitor section allows the input and output signals to be selectively observed using meters and a headphone output.

The Model 5418 is a fully professional product that offers the audio quality, features, and reliability required by 24-hour on-air and commercial applications. Located on the unit's front panel, the eight mic/line audio inputs use standard 3-pin female XLR connectors for easy interfacing with balanced and unbalanced sources. The input circuitry features adjustable gain, P48 phantom power, and high-pass filter functions. Configuration of the inputs can be made locally by using pushbutton switches and an OLED display. Alternately, the STcontroller software application allows remote control of the input parameters. The analog mic/line input audio signals are converted to 24-bit PCM digital and then transported via the Dante interface.

Using the Dante Controller software application, eight digital audio signals can be routed (subscribed) to the Model 5418 via the Dante interface. These input signals are then converted to analog and provided to users as balanced line-level analog outputs. One 25-pin female D-subminiature connector, located on the unit's back panel, provides access to the eight analog outputs.

The monitor section provides the user with the ability to select any input or output signal, or signal pair, for monitoring using the 2-channel (stereo) headphone output. A configuration choice allows selected analog outputs to provide a monitoring function for connection to inputs on amplified loudspeakers. The OLED display offers level metering functions which allow the input or output audio signals to be visually monitored.

The Model 5418 provides three Gigabit Ethernet (GigE) network interfaces, two to support Redundant Dante operation and the third for accessing the management menu system. To meet the latest interoperability standard, the Model 5418's Dante implementation supports AES67-2018. The unit also supports the Dante Domain Manager™ (DDM) software application. An integrated web server allows fast and flexible monitoring and configuration of the unit's networking, audio, and Dante performance. Front-panel indicators, an OLED display, and push-button switches provide users with direct access to key operating parameters.

The Model 5418 can be powered by 100-240 V, 50/60 Hz mains or a source of 12 volts DC. Both can be simultaneously connected to provide redundant operation. The lightweight enclosure mounts in one space (1U) of a standard 19-inch rack. Industry-standard connectors are used for the audio input, audio output, Ethernet, DC power, and AC mains interconnections.

Dante audio-over-Ethernet has found wide acceptance as an audio “backbone” due to its ease of use, interoperability, excellent audio quality, and wide adoption by a large number of equipment manufacturers. The Model 5418 can serve as an “edge” device for Dante network implementations, providing high-performance input, output, and monitor resources in a compact, cost-effective package. The unit can also serve as a general-purpose “tool” to help extend Dante capabilities to facilities and applications that were initially implemented to support signals in the analog domain.



**Figure 1. Model 5418 Mic/Line Interface front view**

## Dante Audio-over-Ethernet

Digital audio data associated with the Model 5418 is interfaced with a local area network (LAN) using Dante audio-over-Ethernet media networking technology. Status LEDs provide a real-time indication of Dante and LAN performance. A major benefit of using Dante is its ability to use any standard Ethernet network implementation, including switches, to directly transport professional audio signals. The Model 5418 supports digital audio signals with a sampling rate of 44.1, 48, and 96 kHz and a bit depth of up to 24. These sampling rates were selected for optimal support of broadcast, production, industrial, and commercial applications.

The signals associated with the eight mic/line input channels are converted to digital and then routed to transmitter (output) channels on the Dante interface. Eight transmitter (output) channels from one or more associated Dante-enabled devices can be assigned to the Model 5418's receiver (input) channels using the Dante Controller software application. These input signals are converted into analog and then, depending on the unit's configuration, sent to the analog output circuitry.

## Network Ports

Using the Dante Controller software application, the Model 5418's two Dante Ethernet ports can be selected to operate in either the Switched or Redundant modes. In the Switched mode, a single Ethernet connection is used for interconnection with other Dante-compliant devices. The second Model 5418 Dante Ethernet port can be used to interface with another piece of network equipment. In the Redundant mode, independent Ethernet connections are made to the unit's two Ethernet ports implementing Dante's redundant network capability.

The Model 5418's third Ethernet port will always be used to access the management webpages. This port can be connected to an independent network that some facilities implement for equipment monitoring

and management purposes. The unit's maintenance port can also be connected to the network that is being used for Dante. It would have a unique IP address and would not interact with the Dante audio data.

## Applications

The Model 5418 is a general-purpose mic/line input, analog output, and monitoring device intended for a variety of audio and audio-for-picture applications that utilize Dante. It's suitable for use in demanding on-air broadcast and live-event applications that require both excellent audio performance and reliable operation. The rack-mounted unit is appropriate for installation in fixed locations, serving the needs of systems associated with stadium, worship, education, commercial, and government facilities. Its lightweight enclosure also makes it suitable for mobile and field uses.

The Model 5418 features an optimized set of controls and indicators that makes it simple and intuitive to use. With the unit's headphone and level monitoring resources it's easy for operators to obtain optimal performance. And by providing standard connectors for all inputs and outputs, along with AC mains and DC powering, setup can be completed in just a few minutes.

## Mic/Line Inputs

The Model 5418 provides eight analog inputs that are compatible with microphone and line-level signals. The mic/line input circuitry allows the level of the connected sources to be boosted as required, converted to digital, and then output to an Ethernet network by way of Dante. Each mic/line input can be individually configured to meet the requirements posed by a wide range of sources. The configuration choices can be made either locally or by way of the STcontroller software application. The preamplifier of each channel can be selected for 0 dB of gain to support line-level sources or 10 to 60 dB of gain, in 1-dB steps, for microphones. A source of P48 phantom power can be enabled to power condenser



Figure 2. Model 5418 Mic/Line Interface back view

microphones. In addition, a high-pass filter (HPF) function can be enabled as required to reduce the presence of unwanted low-frequency content typically associated with hum, rumble, or wind noise.

Compatible signal sources include dynamic, ribbon, and phantom-powered condenser (capacitor) microphones. The preamplifier gain settings of 0 dB and the range of 10 to 20 dB were specifically included to support connection of balanced and unbalanced line-level signals that are commonly provided by professional and semi-professional audio equipment. Typical nominal levels for these sources would be +4 dBu and -10 dBV, respectively. Devices providing these analog signal sources could include audio consoles, wireless microphone receivers, and broadcast playback equipment.

For front-panel space efficiency the eight mic/line input channels share a common configuration section which includes seven pushbutton switches and an OLED display. The buttons allow rapid local selection of the preamplifier gain as well as controlling the on/off status of the P48 phantom power and high-pass filter (HPF) functions. The OLED display allows the preamplifier gain of each mic/line input channel to be observed. Audio channel level metering is also provided as part of the OLED display's resources. The "virtual" meters are calibrated in dBFS which can assist users in optimizing the preamplifier gain settings which in turn will provide the best possible conversion from the analog to the digital domain. LED indicators associated with each mic/line input channel provide the on/off status of the P48 phantom power and high-pass filter (HPF) functions.

The mic/line inputs are electronically balanced (differential), capacitor-coupled, and ESD (static) protected for reliable operation in a variety of demanding applications. Extensive filtering minimizes the chance that radio frequency (RF) energy will cause interference. The inputs are protected from damage should a moderate DC voltage be accidentally connected. The sum of these characteristics makes the mic/line inputs suitable for use in studio and mobile facilities as well as field-deployed environments.

The eight 3-pin female XLR connectors associated with the Model 5418's mic/line inputs were specifically

located on the front panel. This can eliminate the need for an external I/O or "patch" panel, allowing signal sources and their associated interconnecting cables to be rapidly connected and disconnected as required. Rather than being "buried" in the back of a rack enclosure the Model 5418 provides convenient access to the mic/line input connectors and their associated configuration buttons, indicators, and OLED display.

The audio performance of the Model 5418's mic/line inputs is very good. Low-noise, wide-dynamic-range preamplifier circuits ensure that input audio quality is preserved. The P48 phantom power source is extremely low noise, allowing optimal microphone operation and imparting little signal degradation. The outputs of the preamplifiers are routed to high-performance analog-to-digital conversion (ADC) sections that support various sampling rates and a bit depth of 24. A precision voltage-reference circuit helps the ADC circuitry perform highly accurate signal conversion. The audio signals, now in the digital domain, are connected to the Dante interface section where they are packetized and prepared for transport over Ethernet.

## Analog Outputs

The Model 5418 provides eight general-purpose line-level analog output channels. Each of the analog output channels can be individually configured to use as its input source a Dante receiver (input) channel, a mic/line input channel, one of the monitor output channels, or a 1 kHz sine-wave tone. In most applications, a receiver (input) channel associated with the unit's Dante interface will serve as the audio source. The Dante Controller software application would be used to select the source which originates from a transmitter (output) channel on an associated piece of Dante equipment.

Another configuration choice allows signals associated with any of the mic/line inputs to serve as the source for an analog output channel. The selected signal would be post (after) the mic/line input circuitry and provide a broadcast-style "hot mic" line-level analog output version of its associated mic/line input signal. To allow connection to inputs on amplified speakers any analog output channel can be configured to use either of the two monitor outputs as its source. For troubleshooting purposes a 1 kHz

sine-wave tone at  $-20$  dBFS can be assigned as the source for any analog output channel. This would result in an analog output level of  $+4$  dBu.

The Model 5418's analog outputs have a maximum level of  $+24$  dBu. This allows both compatibility and sufficient headroom in SMPTE®-compliant applications where digital audio signals with a nominal level of  $-20$  dBFS need to translate into analog signals that have a nominal level of  $+4$  dBu. For flexibility a configuration menu choice allows the level of each analog output channel to be individually adjusted ("trimmed") over a range of  $\pm 20$  dB in 1-dB steps.

The analog outputs are electronically balanced, capacitor-coupled, and ESD (static) protected. High-quality components, including the important digital-to-analog converters, are used to provide low-distortion, low-noise, and sonically-excellent performance. Robust circuitry provides protection from damage should a moderate DC voltage be accidentally connected, something especially useful in broadcast applications. The analog outputs are compatible with virtually all balanced and unbalanced loads with an impedance of 2 k ohms or greater.

## Input and Output Monitoring

A flexible yet easy-to-use monitor section offers users the ability to listen to and visually observe the level of the audio signals that are associated with the eight mic/line input channels and the eight analog output channels. A mode configuration choice allows monitoring of either a single audio channel or a pair of audio channels. This can be valuable when monitoring monaural or stereo (dual-channel) signals. Using a 3-conductor  $\frac{1}{4}$ -inch jack, located on the front panel, a 2-channel output supports the connection of a pair of stereo headphones. A rotary control allows the level of the headphone output to be adjusted.

For application flexibility a 2-channel line-level analog monitor output can also be created. The analog outputs selected for this function would be connected to inputs on amplified loudspeakers or a power amplifier associated with monitor loudspeakers. In this way, the audio signals that are selected for the headphone output will also be used by the designated analog output channels. A configuration choice allows the selected audio sources to be either pre (before) or post (after) the rotary level control.

The front-panel OLED display provides "bar graph" signal level metering. Depending on how the monitor section is being used, one, two, or eight channels of level can be simultaneously shown. The meters are calibrated in dBFS, directly reflecting the signal level in the Dante transmitter (output) and receiver (input) digital domain.

## Simple Installation

The Model 5418 uses standard connectors to allow fast and convenient interconnections. 3-conductor female XLR connectors, a 25-pin female D-sub-miniature connector, and a 3-conductor  $\frac{1}{4}$ -inch jack are used to interface with the mic/line input, analog output, and headphone output audio signals. The unit connects to local area networks (LANs) using three RJ45 jacks. Multiple LEDs on the unit's back-panel display the status of the network connections. A detachable power cord can be used to connect a source of mains power. Alternately, a DC power source can be connected using a 4-pin XLR connector. The lightweight aluminum enclosure mounts in one space (1U) of a standard 19-inch rack enclosure.

## Operating Power

The Model 5418 allows an AC mains source of 100-240 V, 50/60 Hz to be connected by way of a standard detachable mains power cord. It can also be DC powered using a 10-18 volt source that is connected via a broadcast-standard 4-pin XLR connector. If both AC and DC power sources are connected the unit will be powered by the AC mains supply. Only if the AC mains source fails will a load be placed on the DC source. This allows a source of DC, such as a battery pack, to serve in a backup capacity. With this arrangement normal operation can continue even if AC mains power is lost.

## Future Capabilities and Firmware Updating

The Model 5418 was designed so that its capabilities can be enhanced in the future. A USB receptacle, located on the unit's back panel, allows the application and FPGA firmware (embedded software) to be updated using a USB flash drive. The Model 5418 uses Audinate's Brooklyn circuitry to implement Dante. The firmware in this module can be updated via the unit's Ethernet connections, helping to ensure

that the Dante capabilities remain up to date. All software files and configuration parameters are stored in non-volatile memory.

## Installation

In this section, the Model 5418 Mic/Line interface will be mounted in one space (1U) of an equipment rack. Ethernet network connections will be made using RJ45 jacks. Eight microphone- or line-level analog signal sources can be connected. If desired, eight analog audio output signals can be interconnected. AC mains and/or DC power will be connected.

Up to three Gigabit Ethernet data connections will be made to the Model 5418 using standard RJ45 patch cables. Eight 3-pin female XLR connectors are used to interface with the mic/line input channels. Connections to the analog output channels will be made using one 25-pin D-subminiature connector. AC mains power can be connected to the Model 5418 by means of a detachable cord set that is compatible with the unit's 3-pin IEC 320 C14 inlet connector. Some applications may warrant connection to a source of nominal 12 volts DC which can be made by way of a 4-pin XLR connector. The DC source can be used to power the Model 5418 or it can serve as a backup power source should AC mains be connected.

## What's Included

The shipping carton contains a Model 5418 Mic/Line Interface and instructions on how to obtain an electronic copy of this guide. Also included in the shipping carton is a North-American-standard AC mains cord. For destinations outside of North America the local reseller or distributor should provide an appropriate AC mains cord.

## Mounting the Model 5418

The Model 5418 Mic/Line interface requires one space (1U) in a standard 19-inch (48.3 cm) equipment rack. Secure the Model 5418 into the equipment rack using two mounting screws per side. As the Model 5418 does not contain a fan or other noise-producing sources it can be located where microphones or other "on air" audio sources will be present. It can also be located within a room or other structure where audio monitoring is going to take place. Selecting a location that is convenient for making connections to the mic/line input connectors

on the front panel may be paramount. In addition, it might be important for personnel to be able to access the front panel's buttons and indicators, allowing easy selection of the Model 5418's operating parameters and usage of the performance monitoring capabilities. Of secondary importance but still something to be considered would be having access to the unit's back panel. This contains the Ethernet interfaces, analog audio outputs, and power connectors.

## Ethernet Connections

The Model 5418 provides three Gigabit Ethernet (GigE) ports for flexibility and compatibility with many networking implementations. Two ports are provided for interconnection with one or two local area networks (LAN) associated with Dante audio-over-Ethernet networking schemes. They are labeled PRI for primary and SEC for secondary. Using the Dante Controller software application these ports can be configured for Switched or Redundant Dante operation. The third Ethernet port, labeled MGMT, is dedicated to accessing the Model 5418's management resources. An internal web server function supports the Model 5418's management port's webpages. These webpages are used for configuration, monitoring, and maintenance of Model 5418 operation.

By providing three Ethernet ports the Model 5418 allows support for facilities that utilize independent networks for Dante audio transport and equipment management. In this way, "production" networks that support transport of audio signals by way of a single LAN (for Switched Dante) or two LANs (for Redundant Dante) can be separate from an engineering network that is used by technical personnel for configuring and maintaining a facility or "plant."

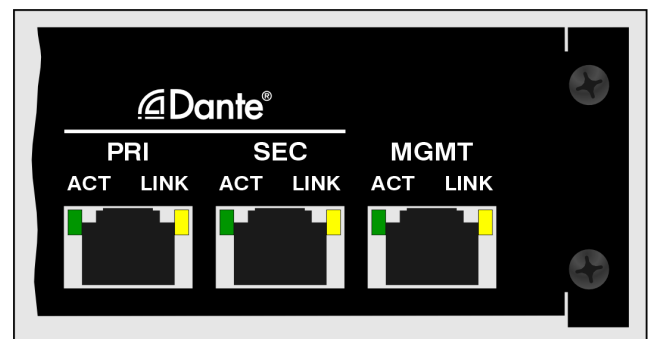

**Figure 3. Detail of Model 5418 back panel showing the Ethernet port's RJ45 jacks**

Connections to the three Ethernet interfaces are made by way of standard RJ45 jacks that are located on the back of the Model 5418's enclosure. The Ethernet interfaces support auto MDI/MDI-X so that crossover cables are not required. Refer to Appendix A for examples of how the Model 5418's three Ethernet interfaces might be utilized. Twisted-pair (UTC) Ethernet has a 100-meter (325-foot) interconnection cable limitation. This can be overcome by using a fiber-optic interconnection between the Model 5418 and the Ethernet switch or switches in the one or more associated local-area-networks (LANs).

### Dante Port Connections

At least one 1000BASE-T Gigabit Ethernet (GigE) connection is required for Model 5418 Dante operation. It should be connected to the primary RJ45 jack. A second 1000BASE-T GigE connection can be made to the secondary RJ45 jack if Redundant Dante is desired. While technically 100BASE-TX (100 Mb/s) Ethernet can also be used for these Dante connections, it is not optimal. Additionally, it's important to note that 10BASE-T (10 Mb/s) Ethernet connections are not sufficient.

When configured in Dante Controller for the Switched network mode, the Model 5418's secondary Dante Ethernet connection can also be used as a "loop through" port such as would be provided by an Ethernet switch. However, using the secondary Dante port for applications other than troubleshooting or "looping" to access the Model 5418's management port is not recommended. It will function reliably but "daisy chaining" Ethernet signals can limit flexibility and present a failure point; it's optimal if each Dante Ethernet interface connects directly to a separate port on an Ethernet switch.

### Management Port Connection

An Ethernet signal is required to be interconnected with the management jack so that Model 5418 configuration and management can be performed. It's recommended that a 1000BASE-T Gigabit Ethernet (GigE) connection be made but a 100BASE-TX (100 Mb/s) or even a 10BASE-T (10 Mb/s) connection is sufficient. (GigE will provide the best performance and it's assumed that all contemporary applications

will support it.) The Model 5418's management port can share a network that is being used by the unit's Dante network connections. Refer to Appendix A for examples of how this can be easily implemented.

### Mic/Line Inputs

The Model 5418 provides eight inputs that are intended for connection to microphone or line-level analog audio signal sources. It's expected that in most applications, the connections to the mic/line inputs will be on a temporary basis, varying "day-to-day" as the applications change. As such, permanent wiring to the eight mic/line inputs is not expected to be made. The 3-pin female XLR connectors, located on the Model 5418's front panel, do not include the traditional latches that would "lock" the mating connectors to them. This was specifically implemented as a feature, allowing mating connectors to automatically release in the presence of significant force. This makes changing input source cables easy and minimizes the chance of damage to the connectors on the Model 5418 or the mating connector should a cable be accidentally grabbed, pulled, or snagged.

Prepare the 3-pin male XLR mating connectors such that pin 2 carries signal high (+), pin 3 carries signal low (-), and pin 1 is common/shield. It's also highly probable that unbalanced sources will interface correctly with the mic/line inputs. With an unbalanced source begin by connecting signal high (+) to pin 2 and signal low/shield (-) to both pins 1 and 3. If this provides a "clean" signal interconnection then all is well. However, if this results in hum or noise on the mic/line input, try connecting signal high (+) to pin 2 and signal low/shield (-) only to pin 3; leave pin 1 unconnected ("floating").

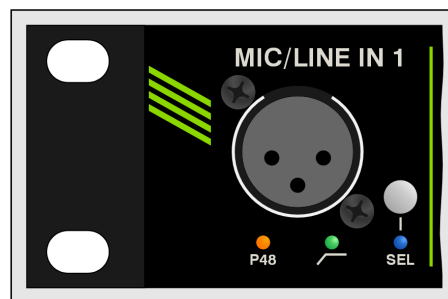

**Figure 4. Detail of Model 5418 front panel showing mic/line inputs (typical of eight)**

## Analog Outputs

The Model 5418 uses one female 25-pin D-subminiature (DB-25F) connector to interface with its eight line-level analog outputs. The connector, located on the unit's back panel, is labeled Analog Outputs. Refer to Appendix B for details on the exact pinout of this D-sub connector.

The wiring scheme used by the D-subminiature connector complies with AES59-2012, as made popular by TASCAM. A wiring assembly prepared for use with the Model 5418's analog output channels should be identical to that of a TASCAM-type output assembly. Note that unlike a TASCAM-type assembly, the Model 5418's D-sub connector uses "locking" screws with 4-40 UNC threads.

The analog outputs are electronically balanced and will perform optimally when driving loads of 2 k (2000) ohms or greater. In most applications, 3-pin male XLR connectors will be used to interface with balanced inputs on the associated devices. In this case, a Model 5418 analog output channel's + terminal would go to pin 2 of the XLR, the – terminal to XLR pin 3, and the shield terminal to XLR pin 1. Balanced connection of the analog output channels is the preferred connection method but unbalanced operation does not pose a problem. To connect to an unbalanced input, connect the + terminal as signal high, and only the Model 5418's shield terminal as the signal low/shield. Leave the – terminal unconnected. For correct unbalanced operation it is important not to connect the – terminal and shield together.

A level trim configuration selection in one of the Model 5418's management webpages allows adjustment of the signal level of each analog output channel in

0.1-dB steps over a –20.0 to +20.0 dB range. This will help to ensure that the analog output channels will be compatible with audio signals and equipment that have a wide range of nominal levels.

## Headphone Output

The Model 5418 provides a 2-channel analog headphone output which is accessible on the front panel by way of a standard 3-conductor ¼-inch tip-ring-sleeve type jack. As would be expected, when the monitor section is selected for stereo operation, the headphone output jack has left channel on its tip lead and right channel on its ring lead. When selected for monaural operation, the same channel will be on both the tip and ring leads. In both cases, channel common will be on the sleeve lead. The audio source or sources for the headphone output circuitry are selected using the unit's monitor section. A rotary control, also located on the front panel, adjusts the level of headphone output.

The headphone output is suitable not just for connection to a pair of stereo headphones. The audio quality is excellent and there's no reason why it can't be used as an analog unbalanced line-level stereo output. It's recommended that for applications of this type that loads of 2 k ohms or greater be connected. Prepare an interface cable such that the tip lead of the mating 3-conductor ¼-inch phone plug serves as signal high (+) for the left channel, the ring lead of the plug serves as the signal high (+) for the right channel, and the sleeve lead of the plug serves as signal low (–) for both the left and right channels. One or more of the analog line output channels can also be utilized for monitor output functions. Configuration choices allow them to take on a pre- or post-level control action.

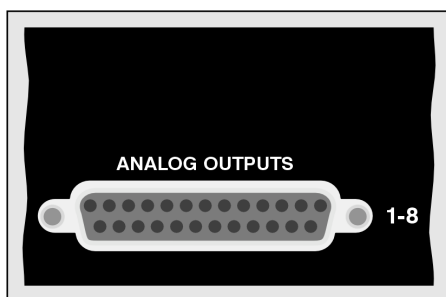

**Figure 5. Detail of Model 5418 back panel showing analog outputs**



**Figure 6. Detail of Model 5418 front panel showing headphone output**

## Connecting Power

The Model 5418 requires a source of AC mains or nominal 12 volts DC for operation. Either source can be connected with the same result. Both can be simultaneously connected if a redundant (backup) power scheme is desired.

### Connecting AC Mains Power

The Model 5418 can operate directly from an AC mains power source of 100 to 240 volts, 50/60 Hz, 20 watts maximum. As a “universal mains input” device there are no switches to set or jumpers to install. A 3-pin IEC 320 C14 inlet connector on the back panel mates with a detachable mains cord set.

All units are supplied from the factory with an AC mains cord that has a North-American (NEMA 5-15L) standard plug on one end and an IEC 320 C13 connector on the other end. Units intended for use in other destinations require that an appropriate mains cord be obtained. The wire colors in the mains cord should conform to the internationally recognized color code and be terminated accordingly:

<u>Connection</u>	<u>Wire Color</u>
Neutral (N)	Light Blue
Line (L)	Brown
Earth/Ground (E)	Green/Yellow

Because the Model 5418 does not contain a power on/off switch it will begin operation as soon as AC mains power is connected.

**Safety Warning:** The Model 5418 does not contain an AC mains disconnect switch. As such, the plug of the AC mains cord will serve as the disconnection device. Safety considerations require that the plug and associated inlet be easily accessible to allow rapid disconnection of AC mains power should it prove necessary.

### Connecting DC Power

The Model 5418 can also operate from a source of 10 to 18 volts DC. The current required from a 12 volts DC source is 1.5 ampere maximum. (1.6 ampere maximum with a 10 volts DC source.) A 4-pin male XLR connector, located on the unit’s back panel, is used to connect the source of DC. Prepare a mating connector (female) so that pin 1 is DC– and pin 4 is DC+. Pins 2 and 3 are not used and should remain

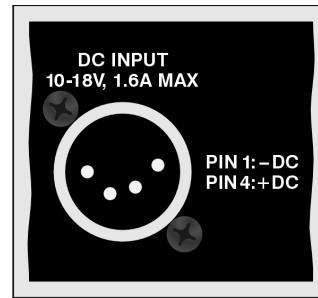

**Figure 7. Detail of Model 5418 back panel showing DC input**

unconnected. This type of connector and pinout have become a broadcast DC power standard and should be familiar to many technical personnel. Because the Model 5418 contains no power on/off switch it will begin operation as soon as a DC power source is connected.

As previously mentioned, both an AC mains source and a DC power source can be connected at the same time. If this is the implementation, the AC mains source will always power the Model 5418 with the DC source serving as a “hot standby.” Only if the AC source fails will the unit draw significant power from the DC source. This will occur automatically with no interruption of Model 5418 operation. In this “standby” mode (when an AC mains source is connected), the Model 5418 will draw less than 120 microamperes (uA) from a connected 12 volts DC source.

## Dante Configuration

For audio to correctly pass to and from the Model 5418 requires, at a minimum, that several Dante-related parameters be configured. These configuration settings are stored in non-volatile memory within the Model 5418’s Dante network interface circuitry. Configuration will typically be done with the Dante Controller software application, available for download free of charge at [audinate.com](http://audinate.com). Versions of Dante Controller are available to support several operating systems.

The Model 5418’s Dante interface is compatible with the Dante Domain Manager (DDM) software application. Refer to DDM documentation, also available from Audinate, for details on which Model 5418 and related parameters may have to be configured.

## Audio Routing

The Model 5418 has eight Dante transmitter (output) channels which are associated with the unit's eight mic/line input channels. The Model 5418 also has eight Dante receiver (input) channels which are typically associated with the unit's eight analog output channels. (Configuration choices allow selection of the signal sources for the Dante transmitter and analog output channels.)

The Model 5418's Dante transmitter (output) channels can be routed (Dante subscribed) to the desired Dante receiver (input) channels on associated equipment. This will assign the channels associated with the Dante transmitter (output) channels to the device or devices that will be "listening" to them. Within Dante Controller a "subscription" is the term used for routing a transmitter flow (a group of up to four output channels) to a receiver flow (a group of up to four input channels).

Also using Dante Controller, the desired Dante transmitter (output) sources can be routed to the Model 5418's Dante receiver (input) channels. These channels will be converted, if so configured, to analog outputs by the Model 5418's circuitry.

As of the writing of this guide, the Model 5418 uses the Brooklyn module to implement its Dante functionality. The number of flows associated with this module is 64; 32 transmitter (output) and 32 receiver (input), and typically no flow limitation will occur. Flows, each of which can support up to four audio channels, can operate either as unicast, multicast, or a combination of the two. Note that when the AES67 mode has been enabled, the Model 5418's Dante transmitter (output) channels will only function in multicast; unicast is not supported.

## Unit and Channel Names

The Model 5418 has a default Dante device name of **ST-M5418-** along with a unique suffix. The suffix identifies the specific Model 5418 that is being configured. The suffix's actual alpha and/or numeric characters relate to the MAC address of the unit's Dante interface module.

The Model 5418's Dante transmitter (output) channels have default names of **Ch1** through **Ch8**. The Model 5418's Dante receiver (input) channels have

default names of **Ch1** through **Ch8**. Using Dante Controller, the default device and channel names can be revised as appropriate for a specific application. Refer to Appendix C for a summary of the default channel numbers, names, and descriptions.

## Device Configuration

The Model 5418 supports audio sample rates of 44.1, 48, and 96 kHz with no pull-up/down options available. The digital audio data is in the form of pulse-code modulation (PCM) samples. Encoding choices within Dante Controller are *PCM 16*, *PCM 24*, and *PCM 32*, but in most cases, the selection of PCM 24 would be appropriate. Clocking and device latency parameters can be adjusted if required but the default values in Dante Controller are typically correct.

## Network Configuration – Dante

The Model 5418 allows connection of three Ethernet signals using standard RJ45 jacks, located on the back panel. Two jacks are for use by Dante and the third for connecting to a network designated for management or maintenance purposes. The Dante ports are labeled PRI and SEC, indicating that they are the primary and secondary connections. How these two ports function can be selected in the Dante Redundancy section of Dante Controller's Network Configuration tab. The choices are *Switched* or *Redundant*.

If *Switched* is selected, the Model 5418 can establish one connection with an Ethernet network. It doesn't matter which RJ45 jack is utilized, although for clarity this would typically be the primary jack. The secondary RJ45 jack can be used to interconnect with another piece of networked equipment.

If the Model 5418's Dante network is configured for Switched ensure that only one of the two Dante RJ45 jacks on the back panel is connected to the LAN associated with the Dante network. If both of the Model 5418's Dante RJ45 jacks are routed to ports on the same LAN this will typically "crash" the network! (Although some of the latest/most-advanced Ethernet switches will automatically detect and prevent such a "network bridging" issue from occurring.)

If *Redundant* is selected, the Dante's Redundant networking capability will be enabled. In this case, separate network connections should be made to the primary and secondary RJ45 jacks.

## Network Configuration – IP Addresses

When the Model 5418 has been configured for the Switched network mode, a single Dante IP address will be associated with the network connection that is made to either the primary or the secondary Dante RJ45 jack. If the network configuration has been selected for *Redundant*, separate IP addresses and related network parameters will be assigned to the primary and secondary Dante Ethernet ports.

Typically, the Model 5418's Dante IP address or addresses and related network parameters will be determined automatically using DHCP or, if that's not available, the link-local network protocol. If desired, Dante Controller allows IP addresses and related network parameters to be manually set to a fixed (static) configuration. While this is a more-involved process than simply letting DHCP or link-local "do their thing," if fixed addressing is necessary then this capability is available.

Note that if the Model 5418's network configuration has been set for Redundant, the primary and secondary Dante IP addresses and related parameters can be independently configured. This allows both interfaces to be configured automatically, both interfaces to be configured manually, or one interface configured automatically and the other configured manually.

## AES67 Configuration – AES67 Mode

Dante Controller allows a Model 5418 to be configured for AES67 operation. This requires the AES67 mode to be set for Enabled. (By default, at the factory it is set for Disabled.) As is previously noted, if AES67 mode is Enabled, the Dante transmitter (output) channels will use multicast. The sample rate will be fixed at 48 kHz.

## Model 5418 Clocking Source

While technically the Model 5418 can serve as a Leader Clock for a Dante network (as can all Dante-enabled devices), in most cases, the unit will be configured to receive its timing reference ("sync") from another Dante device. As such, the Dante Controller check box for the Preferred Leader that is associated with the Model 5418 would typically not be enabled.

## Model 5418 Configuration

Many of the Model 5418's operating parameters can be configured using the webpages that are provided by way of the Model 5418's management Ethernet port. A standard web browser is all that is required to utilize the menu webpages. Of course, the device hosting the web browser must be part of the same network that includes the Model 5418's management Ethernet port. The management port's network configuration can be revised using one of the webpages or by way of the front-panel menus.

## Management IP Address

With the Model 5418 powered and operational, and a network connection made to the management port, a connection to the web server can typically be established. How the management Ethernet port obtains its IP address will depend on a configuration setting. The default configuration method is automatic such that from the factory the Model 5418's management port will first try to obtain an IP address using DHCP. If that is not successful, an IP address will be assigned using the link-local protocol. (A link-local-obtained IP address will be in the format of 169.254.x.x.) It's also possible that the Model 5418 may have been configured to use a manual (fixed or static) IP address. The Model 5418's management webpages can be used to review or make changes to the IP address and related parameters. Alternately, the front-panel display and associated pushbutton switches can be utilized.

It should be simple to identify the active management IP address. Press the front-panel down button four times to view the menu that shows the current management IP address. To minimize the chance of screen damage ("burn in") the unit includes a screen-saver function. It will automatically invoke two minutes after the last press of a front-panel button. When active it will cause a continuous sequence of two pages to show on the front panel. Both will show the Studio Technologies logo, but one reverses the graphics bits from black to white and vice versa. Pressing the down button four times, even when the screen saver is active, will cause the current management IP address screen to show.

## Accessing the Management Webpages

To access the Model 5418's home page, type the Model 5418's management IP address into the browser's search bar. (It's possible that some browsers may require the text **http://** followed by the IP address.)

## Home and Login Menus

Once the Home page shows access to the configuration menus is possible. Click on the link labeled Log In, on the page's right side, and it will lead to the Login menu webpage. The entry of a valid user name and password is now required. This is not a sophisticated security implementation! It is intended to keep "honest" people from making unauthorized changes to the configuration of the Model 5418.

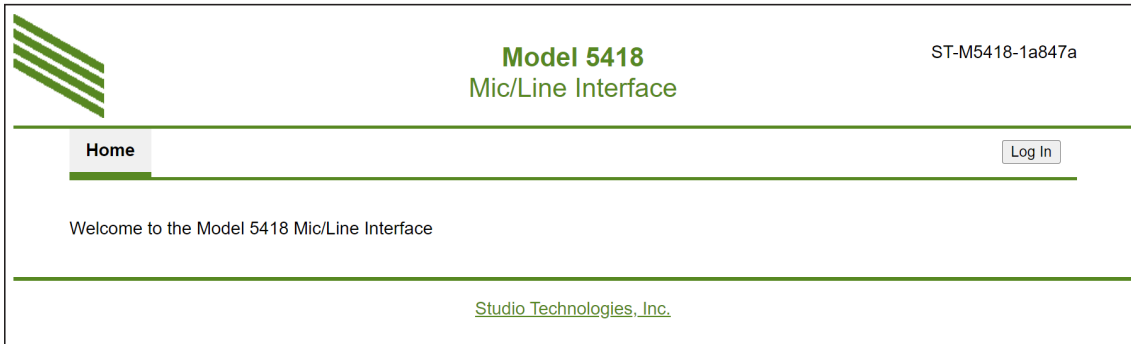

The screenshot shows the home page of the Model 5418 Mic/Line Interface. At the top left is a logo consisting of four green diagonal lines. The title "Model 5418 Mic/Line Interface" is centered, and the ID "ST-M5418-1a847a" is in the top right. A navigation bar contains a "Home" button (which is highlighted) and a "Log In" button. Below the navigation bar, the text "Welcome to the Model 5418 Mic/Line Interface" is displayed. At the bottom, there is a link to "Studio Technologies, Inc."

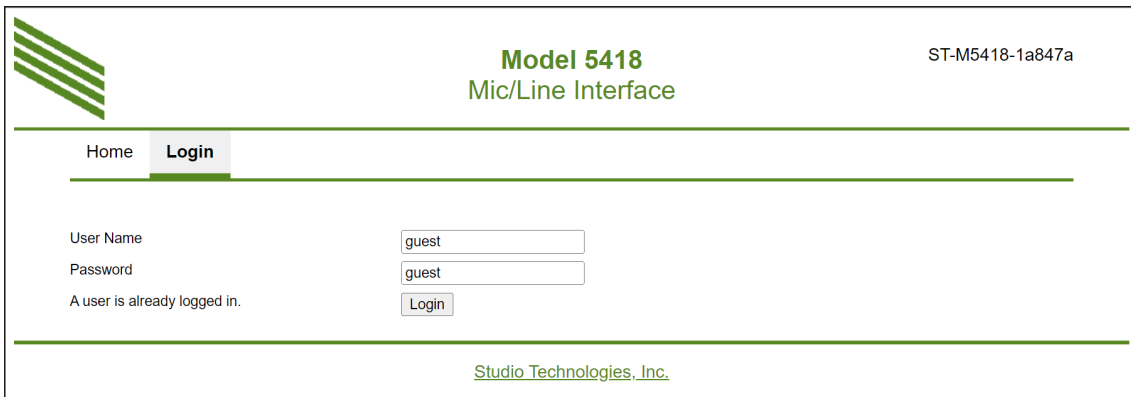

The screenshot shows the login page of the Model 5418 Mic/Line Interface. It features the same logo and title as the home page. The navigation bar now has "Home" and a highlighted "Login" button. Below the navigation bar, there are two input fields: "User Name" with the value "guest" and "Password" with the value "guest". A "Login" button is positioned below the password field. A message "A user is already logged in." is displayed to the left of the login button. At the bottom, there is a link to "Studio Technologies, Inc."

**User Name:** Enter the Model 5418's user name into this field. It is case sensitive. The default user name is **guest**. If the default user name and default password are active, the default user name will show in this field.

**Password:** Enter the Model 5418's password into this field. It is case sensitive. The default password is **guest**. If the default user name and default password are active, the default password will show in this field.

**Login Button:** Click on the Login button to submit the entered user name and password. If the correct entries have been made, access to the configuration menu webpage will show. If an incorrect user name and/or password is entered a login failed message will be shown.

## Configuration Menu Choices

Once a correct user name and password have been submitted the Home menu webpage will again show. In addition, six tabs with other menu choices will also show. The Home menu page now allows the status of three important Model 5418 parameters to be observed. The six other menus allow a number of Model 5418 configuration choices to be shown and, in many cases, revised.

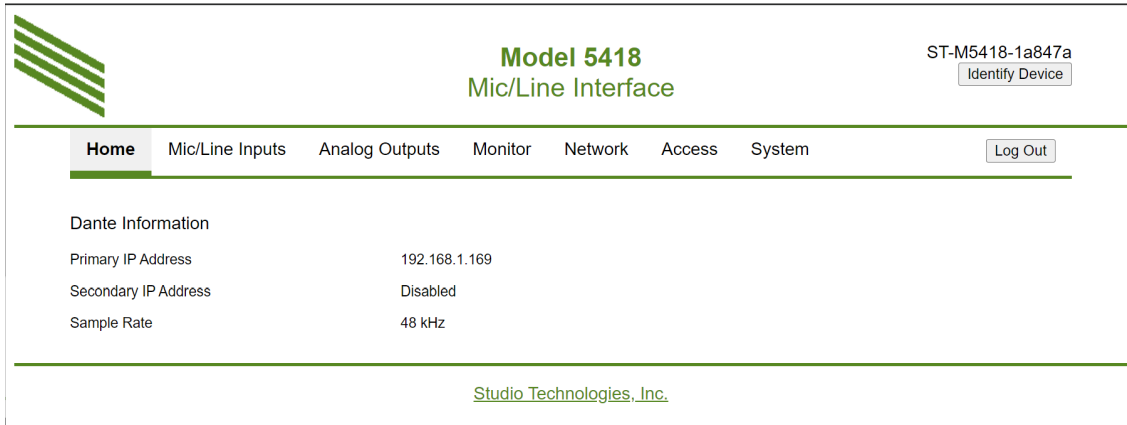

### Dante Information

**Primary IP Address:** This is a display-only field that will show the IP address associated with the Dante primary connection. This address will be shown in the form of four octets separated by periods. If the network configuration in Dante Controller has been selected for *Switched*, the Dante primary connection can be made to either the PRI or the SEC RJ45 jack. If the network configuration in Dante Controller has been configured for Redundant, the primary Dante connection will be made to the PRI RJ45 jack. This field will show **No Ethernet Link** if no connection has been made to an applicable Dante Ethernet port.

**Secondary IP Address:** This is a display-only field that will show the IP address associated with the Dante secondary connection. It will show **Disabled** if the Dante Controller network configuration has been selected for *Switched*. It will show an IP address if Dante Controller's network configuration has been selected for *Redundant* operation and a connection has been made to the SEC RJ45 jack. It will show **No Ethernet Link** if the network configuration has been selected for *Redundant* and no Ethernet connection is present on the SEC RJ45 jack.

**Sample Rate:** This display-only field will show the Model 5418's Dante transmitter (output) sample rate as configured using Dante Controller. Choices are 44.1 kHz, 48 kHz, and 96 kHz.

## Mic/Line Inputs Menu

The Model 5418 provides eight analog input channels which are compatible with line- or microphone-level signals. Three configuration choices are available for each input channel.

Channel	P48	HPF	Gain (dB)
1	<input type="checkbox"/>	<input type="checkbox"/>	0
2	<input type="checkbox"/>	<input type="checkbox"/>	0
3	<input type="checkbox"/>	<input type="checkbox"/>	0
4	<input type="checkbox"/>	<input type="checkbox"/>	0
5	<input type="checkbox"/>	<input type="checkbox"/>	0
6	<input type="checkbox"/>	<input type="checkbox"/>	0
7	<input type="checkbox"/>	<input type="checkbox"/>	0
8	<input type="checkbox"/>	<input type="checkbox"/>	0

Dante Transmitters Source:

Studio Technologies, Inc.

### P48 Phantom Power

Choices are: *Off* (check box not enabled) and *On* (check box enabled)

Each of the eight mic/line input channels allows a source of P48 phantom power to be enabled as desired. Typically used as a power source for a condenser (capacitor) microphone, the state of these functions can be controlled by way of this webpage, the STcontroller application, or using a pushbutton switch that's located on the Model 5418's front panel. The current state of each P48 function will show on the webpage, on the STcontroller application, and by way of an orange LED located the unit's front panel. The LED will light whenever P48 is active for that channel. By design, P48 can be active at whatever gain has been selected for the mic/line input, including 0 dB (line level).

### High-Pass Filter (HPF)

Choices are: *Off* (check box not enabled) and *On* (check box enabled)

Each of the eight mic/line input channels allows a high-pass filter (HPF) function to be enabled. This is typically used to minimize the impact of unwanted low-frequency energy that can be picked up by a connected microphone. The on or off state of the HPF functions can be controlled by way of the webpage, the STcontroller application, or using the pushbutton switches on unit's front panel. The current state of the HPF functions will be shown on the webpage, on the STcontroller application, and by way of green LEDs located on the unit's front panel. An LED will light when the HPF function is active for that channel. By design, the HPF function can be active at whatever gain has been selected for the mic/line input, including 0 dB (line level).

## Gain

Choices are: 0 dB and 10-60 dB in 1-dB steps

The circuitry associated with the Model 5418's eight mic/line input channels can have its gain individually adjusted (trimmed). The channels are labeled 1 through 8 and their gain can be set for 0 dB then 10 through 60 dB in 1-dB steps. Setting a channel for 0 dB of gain would be appropriate for interfacing with line-level signals. (In this situation, connecting an analog signal with a precise level of +4 dBu would result in an output level of -20 dBFS on the associated Dante transmitter (output) channel.) Connecting a dynamic microphone might require setting the gain to 40 dB, 50 dB, or even greater. A condenser microphone with a "hot" output might require less gain for correct operation. Refer to the Operation section for additional details on how to use the level meter functions to optimize the gain settings.

**Submit:** A Submit button is located at the bottom of the configuration choice area. To save changes made to any of the P48, HPF, or Gain fields requires that the Submit button be pressed.

## Dante Transmitters Source

Choices are: *Mic/Line Inputs*, *Dante Receivers*, and *1 kHz Tone*

There are eight Dante transmitter (output) channels associated with the Model 5418. The signal sources for these Dante transmitters, as a group, can be selected from among three choices. Selecting *Mic/Line Inputs* is the usual setting. This will cause the Model 5418 to always use mic/line inputs 1-8 as the sources for Dante transmitter channels 1-8. These are connected one-to-one, with mic/line input 1 routed to Dante transmitter 1, mic/line input 2 routed to Dante transmitter 2, and so forth through channel 8.

Selecting *Dante Receivers* causes the Model 5418's eight Dante receiver (input) channels to be used as the signal sources for the eight Dante transmitter (output) channels. The channels are mapped one-to-one, with Dante receiver channel 1 routed to Dante transmitter channel 1, Dante receiver channel 2 routed to Dante transmitter channel 2, etc. This setting can be considered as a Dante loopback function that would typically only be used for test purposes.

Selecting *1 kHz Tone* causes a precise 1000 Hz (1 kHz) sine-wave tone with a level of -20 dBFS to be present on all eight of the Model 5418's Dante transmitter (output) channels. This is an excellent method of providing a known signal source on all eight of the Dante transmitter (output) channels and should prove useful in test and troubleshooting situations. The Model 5418 does not allow the frequency and/or overall output level of these tones to be adjusted.

**Submit:** A Submit button is located below the source selection box. To save the selected choice requires that the Submit button be pressed.

## Analog Outputs Menu

The Model 5418 provides eight analog output channels. Each channel can have its source selected and its output gain adjusted (“trimmed”).

Channel	Source	Gain (±dB)
1	Dante Receiver 1	0
2	Dante Receiver 2	0
3	Dante Receiver 3	0
4	Dante Receiver 4	0
5	Dante Receiver 5	0
6	Dante Receiver 6	0
7	Dante Receiver 7	0
8	Dante Receiver 8	0

[Studio Technologies, Inc.](#)

### Source

Choices are: *Mic/Line In X*, *Dante Receiver X*, *1 kHz Generator*, *Monitor Y Pre-Fader*, and *Monitor Y Post-Fader*. *X* is the channel number. *Y* is 1 for the odd analog output channels and 2 for the even analog output channels.

The Model 5418 is unique in that each of the eight analog outputs can have its source selected from among five choices. Selecting *Mic/Line In* as the source for an analog line output will create what an audio console would consider to be a direct out function. The output of the preamplifier associated with a mic/line input circuit will be the source for the analog output. While probably not the typical setting, it can be useful for special applications including during installation, deployment, and testing. Selecting *Dante Receiver* is the usual setting, configuring the Model 5418s to use the Dante receiver (input) channel as the signal source for the analog output channel. Selecting *1 kHz Tone* makes a 1 kHz sine-wave tone with a level of +4 dBu nominal be present on the analog output channel. This is an excellent method of providing a known signal on the analog output channel and is

expected to be useful for test situations. The Model 5418 does not allow the frequency of the tone to be adjusted.

Selecting *Monitor Pre-Fader* allows an analog output to be used as part of a monitoring function. The channel selected for monitoring using the front-panel pushbutton switches will be routed to the analog output channel and its level won't be impacted by the rotary level control on the front panel. It will be electrically “pre” (before) the headphone level control (“fader”). Selecting *Monitor Post-Fader* will use the same source but the output level will be controlled by the front-panel rotary level control. Having the choice of pre- or post-fader allows connection to a variety of monitor systems, including amplified loudspeakers, that may, or may not, include integrated level controls.

### Gain Adjustments

The circuitry associated with the Model 5418's eight analog output channels can have their gain individually adjusted (trimmed). The channels are labeled 1 through 8 and the gain range is –20.0 to +20.0 in 0.1-dB steps. These gain trim functions can be used

to allow the relative level of each analog output channel to be matched. They can also be used to adjust the analog output levels such that their nominal level is something different than the unit's default nominal level of +4 dBu. (The default nominal level is achieved with a gain level setting of 0 dB.) The level adjustment settings will apply to each analog output channel, no matter what signal source has been selected. This means that the level trim settings will apply to their associated analog outputs whether the mic/line input, Dante receiver (input), 1 kHz tone generator, or monitor pre- or post-fader is serving as the channel's audio source.

**Submit:** A Submit button is located below the configuration fields. To save changes made to any of the sixteen fields requires that the Submit button be pressed.

## Monitor Menu

The Model 5418 provides an audio monitor section, allowing a user to confirm performance of the eight mic/line input and eight Dante receiver (input) channels. The monitor webpage allows the overall mode and signal source or sources to be selected for monitoring. Five pushbutton switches and a level control on the front panel of the unit are also used by the monitor function. A headphone output jack is located on the front panel and, if desired, one or more of the analog output channels can be configured for use as monitor outputs.

The screenshot shows the web interface for the Model 5418 Mic/Line Interface. At the top, there is a logo on the left, the title "Model 5418 Mic/Line Interface" in the center, and the device ID "ST-M5418-1a847a" with an "Identify Device" button on the right. Below this is a navigation menu with options: Home, Mic/Line Inputs, Analog Outputs, Monitor (highlighted), Network, Access, System, and a Log Out button. The main content area has two sections. The first section is for "Mode", with a dropdown menu set to "Stereo" and a "Submit" button below it. The second section is for "Source" and "Channel". The "Source" dropdown is set to "Mic/Line Inputs" and the "Channel" dropdown is set to "1/2". Both have "Submit" buttons below them. At the bottom of the page, there is a link to "Studio Technologies, Inc."

### Mode

Choices are *Mono* and *Stereo*

The overall operation of the Model 5418's monitor section can be configured for monaural or stereo. The choice of operating mode can be made using a selection on the webpage or using a button press on the front-panel menu. When selected for *Mono*, a signal is routed to both the left and right monitor output channels. When selected for *Stereo*, a signal on an odd channel (1, 3, 5, or 7) is routed to the left monitor output channel while a signal on an even channel (2, 4, 6, or 8) is routed to the right channel.

**Submit:** A Submit button is located below the selection box. To save the selected choice requires that the Submit button be pressed.

### Source

Choices are *Mic/Line Inputs* and *Dante Receivers*

When *Mic/Line Inputs* is selected, the monitor sources are the outputs of the preamplifier circuits associated with the eight mic/line inputs. When *Dante Receivers* is selected, the monitor sources are the signals associated with the eight Dante receiver (input) channels.

### Channel

When the overall monitor mode is selected to be *Mono*, the Channel choices are 1, 2, 3, 4, 5, 6, 7, and 8. This makes sense as only one signal is to be monitored at any one time.

When the overall monitor mode is elected to be *Stereo*, the Channel choices are 1/2, 3/4, 5/6, and 7/8. These are, as expected, pairs of signals.

**Submit:** A Submit button is located below the two selection boxes. To save the selected Source and Channel choices requires that the Submit button be pressed.

## Network Menu

**Model 5418**  
Mic/Line Interface

ST-M5418-1a847a  
Identify Device

Home Mic/Line Inputs Analog Outputs Monitor **Network** Access System Log Out

Reload

Current Network Information	Dante Primary	Dante Secondary	Management
IP Address	192.168.1.169		192.168.1.194
Subnet Mask	255.255.255.0		255.255.255.0
Gateway	192.168.1.1	Disabled	192.168.1.1
MAC Address	00-1D-C1-1A-84-7A		00-04-22-F7-00-00

Management Interface Configuration

IP Configuration: Automatic

Manual IP Address: 192.168.1.18

Manual Subnet Mask: 255.255.255.0

Manual Gateway: 192.168.1.1

Submit

Studio Technologies, Inc.

### Current Network Information

Each Model 5418 has three Ethernet interfaces: Dante Primary, Dante Secondary, and Management. Three columns, each consisting of four fields, provides important network information about the interfaces. If the Dante network configuration has been selected for *Switched* operation, the Dante Secondary interface will be disabled and the text **Disabled** will show.

**IP Address:** These are display-only fields that show the IP addresses actively associated with the interfaces. Shown in dot-decimal notation.

**Subnet Mask:** These are display-only fields that show the subnet mask values actively associated with the interfaces. Shown in dot-decimal notation.

**Gateway:** These are display-only fields that show the gateway addresses actively associated with the interfaces. Shown in dot-decimal notation.

**MAC Address:** These are display-only fields that show the MAC (media access control) addresses associated with the interfaces. These are unique hardware identification numbers that are assigned to each specific Model 5418 Ethernet interface.

### Management Interface Configuration

The method used by the management Ethernet interface to obtain its IP address can be selected. Specific values can be entered should the manual IP address selection method be chosen.

**IP Configuration:** This is a configurable field with two choices: *Automatic* and *Manual*. It impacts how the Model 5418 obtains the IP address that is used for accessing the Model 5418's management web server and associated menu webpages. This setting has no impact on how the Model 5418 obtains the primary and secondary IP addresses that are associated with its Dante Ethernet interfaces.

Selecting *Automatic* will cause the Model 5418 to use DHCP or IPv4 link-local to establish the IP address for accessing the Model 5418's management interface. With this setting, upon establishing a link to the Model 5418's management RJ45 jack the DHCP protocol will request an IP address and related parameters. If obtaining an IP address by way of a DHCP server is not successful, the IPv4 link-local protocol will be used. If the established IP address has the format of 169.254.x.x then it was assigned using the IPv4 link-local.

Even if the management IP address was established using link-local the DHCP protocol will stay active. The Model 5418's firmware will continue to check for the presence of a DHCP server. If one becomes available then an IP address will be requested and, when obtained, will automatically be used, replacing the IP address that was previously established by link-local.

The *Manual* setting allows the desired IP address and related parameters for the management Ethernet interface to be manually entered. This can be useful when a fixed addressing scheme has been established. In this way, a "static" IP address can be entered along with the other important network parameters.

When selected for *Automatic*, the fields for Manual IP Address, Manual Subnet Mask, and Manual Gateway will be "grayed out" (will have a gray background) to indicate that their values cannot be manually changed. In this condition, they are display-only. Changing between Automatic and Manual and vice-versa will not impact the values stored in the Manual IP Address, Manual Subnet Mask, and Manual Gateway fields. Note that the front-panel display and associated pushbutton switches can also be used to revise the Model 5418's management IP address configuration.

Note that to minimize the chance of losing access to the Model 5418's management web server, restoring the unit's factory defaults will not change the currently selected IP configuration choice.

**Manual IP Address:** This field is grayed out and will not show any text when the IP configuration mode is selected for *Automatic*. When the IP address configuration is selected for *Manual*, this field will show the IP address that is stored within the Model 5418. This is the IP address that is currently being used, or will be used at the time of the next Ethernet management connection reboot. This IP address allows access to the Model 5418's management web server and associated menu webpages. It has nothing to do with the IP addresses associated with the primary and secondary Dante Ethernet connections.

The manual IP address can be modified as desired to meet the requirements of the application. After entering an IP address using the standard dot-

decimal notation format (four octets separated by dots) the Submit button must be pressed for the changes to be stored. Restoring the Model 5418 to its default values will not change the stored IP address. A system reboot is required for a revised manual IP address to be utilized. Note that the front-panel display and associated pushbutton switches can also be used to revise the Model 5418's manual IP address (although it is less convenient).

**Manual Subnet Mask:** This field is grayed out when the IP configuration mode is selected for *Automatic*. This field will be display-only in this instance and will show an IPv4 subnet mask value in dot-decimal notation (four octets separated by dots) if the current IP address and related network parameters were obtained by way of DHCP. This is the subnet mask that is being used by the unit's management web server. If the IP address configuration mode is selected for *Automatic* and the current IP address was obtained by way of link-local, a subnet mask address of 255.255.0.0 will be shown in this field.

When the IP configuration model is selected for *Manual*, the manual subnet mask field will not be grayed out. In this situation, the stored subnet mask will be shown and can be modified as desired to meet the requirements of the application. The value shown is the subnet mask that is currently in use, or will be used at the time of the next Ethernet management connection reboot. After entering the desired subnet mask value using the standard dot-decimal notation format (four octets separated by dots) the Submit button must be pressed for the change to be stored. A system reboot is required for the revised subnet mask value to be utilized. Note that the front-panel display and associated pushbutton switches can also be used to revise the Model 5418's management subnet mask. Restoring the Model 5418 to its default values will not change the stored manual subnet mask value.

**Manual Gateway:** This field is grayed out when the IP configuration mode is selected for *Automatic*. This field will be display-only in this instance and will show an IPv4 gateway IP address in dot-decimal notation (four octets separated by dots) if the current IP address and related network parameters were obtained by way of DHCP. This is the gateway IP address that is being used by the Model 5418's management web server.

If the IP configuration mode is selected for *Automatic* and the current IP address was obtained by way of link-local, no gateway IP address will be shown in this field. This is because no gateway IP address is associated with link-local.

When the IP configuration mode is selected for *Manual*, the gateway IP address field will not be grayed out. In this situation, the stored gateway IP address will be shown and can be modified as desired to meet the requirements of the application.

The shown value is the gateway IP address that is currently in use, or will be used at the time of the next Ethernet management connection reboot. After entering a gateway IP address using the standard dot-decimal notation format (four octets separated by dots) the Submit button must be pressed for a change to be stored. A system reboot is required for the revised gateway IP address to be utilized. Restoring the Model 5418's default values will not change the stored gateway IP address value.

**Submit:** A Submit button is located near the bottom of the Network menu webpage. To save any changes made to the Network configuration, the Submit button must be pressed.

## Access Menu

### Front Panel Control

Choices are: *View/Edit*, *View Only*

A graphics display and five associated pushbutton switches are located on the Model 5418's front panel. This field allows the action of the pushbutton switches to be selected between two choices. When *View/Edit* is selected, the buttons can be used to select what is shown on the display as well as allowing several configuration choices to be changed. When *View Only* is selected, the pushbutton switches will only allow selection of what information is to be shown. The buttons will not allow any configuration changes to be made. Refer to Appendix E for a detailed list of the front-panel menus.

**Submit:** A Submit button is located below the Front Panel Control selection field. This button must be pressed for a change made to the Front Panel Control configuration to be saved.

### Management Login Credentials

As a security method a user name and password must be entered before the configuration webpages can be accessed. These values can be changed as desired.

The Model 5418's access security method is in no way rigorous. The user name and password are sent to and received from the Model 5418 as plain

text. They are also stored within the Model 5418 as plain text. There is no security method or encryption associated with these fields. Anyone "snooping" on the LAN that is transporting Model 5418 management data will see all values in plain text! The user name and password values are intended simply to provide a means of keeping "friendly" or "honest" users from easily changing the configuration of a Model 5418. If unauthorized access is of concern, it's recommended that an Ethernet connection to the Model 5418's management RJ45 jack not be present except when access by authorized personnel is desired.

The default user name is **guest** and the default password is **guest**. These are case sensitive. If neither of these default values are changed, they will show in the User Name and Password entry fields on the Login menu webpage. If the default user name and/or default password are changed then neither the user name nor the password will show upon accessing the Login menu webpage.

**User Name:** In this field, a revised user name can be entered. It must be a minimum of five characters, a maximum of 15 characters, and is case sensitive. All 95 of the printable ASCII characters can be used. These include upper and lower alphabetic characters, numbers, and standard punctuation marks.

**New Password:** In this field, a revised password can be entered. The password is a minimum of five characters, a maximum of 15 characters, and is case sensitive. All 95 of the printable ASCII characters can be used. These include upper and lower alphabetic characters, numbers, and standard punctuation marks.

**Confirm New Password:** For a new password to be considered valid it must also be entered in this field.

**Submit:** A Submit button is located below the field for Confirm New Password. To save a change made to the User Name field and/or New Password field requires that the Submit button be pressed.

## System Menu

Model 5418  
Mic/Line Interface

ST-M5418-1d7576  
Identify Device

Home Mic/Line Inputs Analog Outputs Monitor Network Access **System** Log Out

Serial Number 01600

Version Information

	Version	Date
Main MCU Firmware	3.00	14 Dec 2022
Secondary MCU Firmware	1.01	24 Jan 2019
FPGA Firmware	1.01	30 Aug 2021
Dante Product	4.4.0	23 Aug 2022
Dante Firmware	4.2.7.4	---

Restore Default Configuration

Operational Settings

Management Interface and Access Settings

Submit

System Reboot

Reboot

[Studio Technologies, Inc.](#)

**Serial Number:** This is a display-only field that shows the Model 5418's hardware serial number. A 5-digit number, it is assigned at the factory and cannot be changed.

### Version Information

Nine display-only fields show information about the firmware (embedded software) that is currently loaded and operating in this specific Model 5418.

**Main MCU Firmware:** Two display-only fields show the version number and release date of the Model 5418's Main MCU firmware. This is the firmware that runs in the Model 5418's microcontroller (MCU) integrated circuit. This firmware can be updated using a USB flash drive. Details are provided in the Technical Notes section.

**Secondary MCU Firmware:** Two display-only fields show the version number and release date of the Model 5418's Secondary MCU firmware. This is the

firmware that runs in the Model 5418's motherboard microcontroller (MCU) integrated circuit. This firmware can be updated using a USB flash drive. Details are provided in the Technical Notes section.

**FPGA firmware:** Two display-only fields show the version number and release date of the firmware used by the Model 5418's programmable logic (FPGA) device. This is the firmware that runs in the Model 5418's high-speed logic device. This firmware can be updated using a USB flash drive. Details are provided in the Technical Notes section.

**Dante Product:** Two display-only fields show the product version number and date that's contained in the Model 5418's Dante interface (Brooklyn module). These numbers and dates are assigned by Studio Technologies as an identifier when releasing a version of the Dante firmware. The firmware for the Model 5418's Dante interface can be updated by way of an Ethernet connection using the Dante Updater

software application that's provided as part of the Dante Controller software application.

**Dante Firmware:** This is a display-only field that shows the version number of the firmware associated with the Dante interface (Brooklyn module) that the Model 5418 utilizes for Dante interconnectivity (there is no associated date). This version number is assigned by Audinate and can't be changed by Studio Technologies, Inc. As noted previously, the firmware for the Model 5418's Dante interface can be updated by way of an Ethernet connection using the Dante Updater software application.

**Restore Default Configuration:** There are two check boxes associated with the restore default configuration function. Either or both can be selected prior to pressing the Submit button. Enabling the Operational Settings check box allows all the Model 5418's configuration settings to be restored to their factory default values with the exception of the management interface and user access settings. The six configuration values associated with these two functions will not change. Enabling the Management Interface and Access Setting check box allows the Model 5418's factory default configuration settings for the IP Address Configuration method, Manual IP Address, Subnet Mask, Gateway IP Address, User Name, and Password to be returned to their factory default values. Refer to Appendix F for a list of these values.

**System Reboot:** A check box and a reboot button are provided in the System Reboot section of this menu page. This function is provided to allow a user to force the Model 5418 to restart operation. Any changes made to the network configuration and/or user name and password settings will be in effect. Once the Reboot check box has been enabled, pressing the Reboot button will cause the Model 5418 to halt current operation and restart ("boot") the unit.

## **Webpage Inactivity Timer/ Automatic Log Out**

Once a web browser has successfully logged into the Model 5418's menu system an inactivity timer will become active. If no configuration setting has been changed, a webpage refreshed, or a webpage

newly accessed for 15 minutes, the user will automatically be logged out. Returning to the menu pages will require the login procedure to be successfully completed.

## **Menu Text and Links**

The following paragraphs provide details on some of the links, buttons, and text that are presented on the Model 5418's webpages.

**Company Name Link:** On the bottom of each webpage is a link with the title Studio Technologies, Inc. Clicking on this link will cause the browser to open the home webpage of the Studio Technologies website.

**Device Name:** In the upper-right corner of each Model 5418 webpage is the Model 5418's Dante device name. This name is unique to each device in a Dante deployment and is used as part of Dante subscriptions (channel routing). The name can be changed from within the Dante Controller application.

**Identify Device Button:** In the upper-right corner of most Model 5418 webpages is a button called **Identify Device**. Clicking on it will cause the Dante identify action to commence on the specific Model 5418 unit. A unique lighting sequence will take place using the eight blue SEL LEDs that are located on the Model 5418's front panel. The *Identify* command will help users ensure that the web server on the desired Model 5418 is being accessed.

**Log Out Button:** A button called Log Out is located in the upper-right of each Configuration menu webpage. It will cause the Model 5418's web server to end the active session and log out the user. To again access the menu webpages will require that a user provide a valid user name and password.

## Operation

Now that the Model 5418 is installed and configured it's ready for use. There are a number of nuances in the unit's operation which may make it useful for technical personnel to spend some time reviewing this section.

Upon application of AC mains or DC power, the Model 5418 will go through a power-up sequence. The LED associated with the USB receptacle on the unit's back panel will briefly light green to indicate that it is functioning. The LEDs associated with the Model 5418's three Ethernet jacks will flash several times as part of the associated Ethernet interface integrated circuit's power-up action. The 25 LEDs on the unit's front panel will light in a confirmation sequence. After that has completed, the display will then enter its "screen save" mode which shows the Studio Technologies logo. The operating condition of the Model 5418 as it was at the time of the previous power down will be restored. All configuration settings will be restored and normal unit activity will begin. The pushbutton switches associated with the default display functions will become active.

### RJ45 LED Indicators

On the Model 5418's back panel there are three RJ45 jacks that are provided for interfacing with the unit's three Gigabit Ethernet (GigE) ports. Two of the jacks are designated for Dante audio use and the third for management functions. The three RJ45 jacks are labeled PRI, SEC, and MGMT. Associated with each jack are two LEDs. One LED is labeled LINK and lights orange when a GigE connection has been established with that specific jack. The LINK LED will not light if a 100 Mb/s Ethernet connection has been made. It will also not light if an Ethernet connection has not been made. The second LED, labeled ACT, will flash green to indicate data activity, responding to Ethernet traffic traveling to and from that specific jack.

### Mic/Line Input Configuration

Each of the eight mic/line inputs can be individually configured for its P48 microphone phantom power on/off status, its high-pass filter (HPF) function on/off status, and the gain of its associated preamplifier circuit. One display is "shared" by all eight mic/line input channels (along with the monitor section). It indicates the status of the P48 phantom power function, the

status of the HPF function, and provides a level meter function associated with the output of the microphone preamplifier. The display also allows configuration of the microphone preamplifier gain value. Pushbutton switches adjacent to the display allow the gain of the preamplifier to be adjusted. Buttons are also provided to control the status of the P48 and HPF functions.

Three LED indicators and a pushbutton switch are associated with each of the eight mic/line input sections on the front panel. Two LED indicators will light to indicate the status of the P48 and HPF functions. The pushbutton switches, labeled SEL, each have an associated LED. The switch is used to select that specific mic/line input section for assignment to the display and its associated buttons.

Momentarily pressing (tapping) a SEL button will cause its associated LED to light and the display will indicate information about that specific mic/line input section. The pushbutton switches associated with the display can then be used to configure the selected mic/line input section's P48 function, HPF function, and preamplifier gain. Momentarily pressing (tapping) the P48 and HPF buttons change their status. The P48 and HPF LEDs in the selected mic/line input section will change state in response to a change in the function. The up arrow button will increase the preamplifier gain in 1-dB steps. The down arrow button will decrease the preamplifier gain in 1-dB steps. The right arrow button will increase the preamplifier gain in 5-dB steps. (With an exception being if the gain is set within the range of +11 to +14 dB, then pressing the right button will cause the gain to move to +15 dB.) The left arrow button will decrease the preamplifier gain in 5-dB steps. (With an exception being if the gain is within the range of +11 to +14 dB, then pressing the left button will cause the gain to move to +10 dB.) If the preamplifier gain is set for 10 dB any gain down command will move the gain to 0 dB. If the preamplifier gain is set to 0 dB then any gain up command will move the gain to 10 dB.

Whenever an input section has a change made to its P48, HPF, or preamplifier gain setting the LED associated with that input select switch will flash three times. As discussed previously, if an input section is currently selected, the LED associated with that switch will light. Pressing the select pushbutton switch again will "release" that mic/line input section, turning

off the LED and returning the display and associated pushbutton switches to perform their default actions.

## Audio Monitoring

A monitor section is provided on the far-right side of the Model 5418's front panel. This allows audio monitoring of the unit's eight mic/line input channels and eight Dante receiver (input) channels. A headphone jack, push-in/push-out level control, pushbutton switch, and an LED are associated with the headphone monitor function. The monitor output is in the form of a 1/4-inch 3-conductor jack that is compatible with all standard stereo headphones (tip left, ring right, and sleeve common). The rotary level control is used to adjust the level of the stereo signal that is sent to the headphone output jack. The pushbutton switch, labeled SEL, is used to select the headphone monitor section for configuration. The display and up and down arrow buttons are used to select the specific audio signal or signals to be monitored.

When the switch associated with the headphone monitoring section is momentarily pressed (tapped), the LED associated with it will light. The display will then indicate the current status of the monitor section. It will show either one number or a pair of numbers to indicate which channel or channels are currently being monitored. If a single audio channel is being monitored, it will be sent to both the left and right channels of the headphone output. If two audio channels are being monitored, the first channel of the "pair" is sent to the left headphone output channel. The second channel of the "pair" is sent to the right headphone output channel. To switch (toggle) between monitoring a single channel and two channels, or vice-versa, simultaneously press and hold both the up and down arrow buttons.

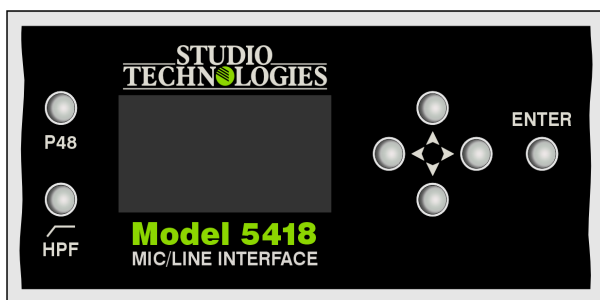

**Figure 8. Detail of Model 5418 front panel showing monitor section**

Depending on the configuration of the monitor section, the up arrow and down arrow pushbutton switches will select either one signal or two signals. The signal or signals selected for monitoring will be saved. In the event of a power down/power up situation, the Model 5418 will return to the same monitor state. Pressing the select button when it is active will "release" the monitor section, disabling the LED and returning the display and associated pushbutton switches to perform their default actions.

## Front-Panel Display Page Descriptions

The following sections provide information about the Model 5418's front-panel menu pages. Additional details about some of the functions can be found in the Model 5418 Configuration section. Refer to Appendix E for details about the menu structure diagram.

The Access Menu web configuration menu page has a selection called Front Panel Control. When the choice of *View/Edit* is selected, the five front-panel pushbutton switches are, in certain circumstances, able to revise a number of Model 5418 configuration parameters. An arrow icon will show in the upper-right corner of twelve pages if a configuration change on that specific page can be made. If the Front Panel Control configuration is selected for *View Only*, no configuration changes can be made on that page using the pushbutton switches. In this case, a lock icon will show in the upper-right corner of the menu page.

### Row One

There are two display-only menu pages associated with the top row which we'll refer to as row one. These show the real-time signal levels of the eight Dante transmitter (output) channels and the eight analog output channels.

### Dante Transmitter (Output) Channel Level Meters:

This menu page will show, in the form of vertical bar graphs, the real-time levels of the eight Dante transmitter (output) channels. The levels are shown in dBFS with reference marks on the left and right sides shown at -20 dBFS. (This is the Model 5418's default Dante transmitter (output) level.) The channel number is noted along the bottom of the display.

**Analog Output Channel Level Meters:** This menu page will show, in the form of vertical bar graphs, the real-time levels of the eight analog output channels. The levels are shown in dBu with reference marks on the left and right side shown at +4 dBu. (This is the Model 5418's default analog output level.) The channel number is noted along the bottom of the display.

### Row Two

There are eight menu pages associated with row two. They are essentially identical except that each is associated with one of the eight analog output channels. Each menu allows display of the current settings for a channel's signal source and gain configuration. If the front-panel controls are configured for view/edit, then those configuration settings can be edited as desired. The source choices are the same as offered using the configuration webpages: *Mic/Line Input*, *Dante Receiver*, *1 kHz Tone*, *Monitor Pre-Fader*, and *Monitor Post-Fader*. The gain trim is adjustable over the same  $\pm 20$  dB range.

If an arrow icon shows in the upper-right corner of a menu page it indicates that the setting can be changed. If a change is desired, press the Enter pushbutton switch which is located on the front panel. Use the up and down arrow buttons to select the desired source. (For clarity, the configuration choice that is currently active will have an asterisk (\*) at the end of its name.) Then again press the Enter button. The entry will be stored and the selected sources utilized. The gain trim can also be adjusted in a similar manner. Press the Enter button to save the selected gain trim value.

### Row Three

There are three pages associated with row three. One page shows the source configuration for the Dante transmitter (output) channels. Depending on the unit's configuration, that selection might be able to be changed. Another page shows the primary and secondary Dante IP address. The third page shows the Dante product version number and the Dante firmware version number.

#### **Dante Transmitters (Outputs) Source Select:**

This menu page shows the currently selected signal sources, as a group, that are used for the Dante transmitter (output) channels. If the menu page is configured for View/Edit, it will also allow selection

from among three choices: *Mic/Line Input*, *Dante Receiver*, and *1 kHz Tone*. A lock icon will indicate that the source cannot be changed. An arrow icon will show in the upper-right corner of this menu page to indicate that the setting can be changed.

If the arrow is present, press the Enter pushbutton switch located on the front panel to start the change process. Use the up and down arrow buttons to select the desired sources. (For clarity, the configuration choice that is currently active will have an asterisk (\*) at the end of its title.) Once the desired choice has been selected, press the Enter button. The entry will be stored and the selected sources utilized.

**Dante Primary and Secondary IP Addresses:** This menu page shows the IP addresses associated with the Dante primary and secondary interfaces. These addresses have nothing to do with the IP address utilized by the management interface port. The standard dot-decimal notation is used to show these IP addresses.

If the network configuration is selected for *Switched* in the Dante Controller application, the Dante primary IP address will be associated with an Ethernet connection made to either the primary or the secondary RJ45 jack on the Model 5418's back panel. If no Ethernet connection has been made to either RJ45 jack, the text **No Ethernet Link** will show for the Dante primary IP address. The text **Disabled** will show for the Dante secondary IP address.

If the network configuration is selected for *Redundant*, the Dante primary IP address will be associated with the RJ45 jack labeled PRI on the Model 5418's back panel. If no Ethernet connection has been made to this RJ45 jack, the text **No Ethernet Link** will show. The Dante secondary IP address will be associated with the RJ45 jack labeled SEC on the Model 5418's back panel. If no Ethernet connection has been made to this RJ45 jack, the text **No Ethernet Link** will show.

**Dante Product and Firmware Version:** This menu page shows the product firmware version number and Dante firmware associated with the Model 5418's Dante interface. As of the writing of this guide, the Model 5418's Dante interface is implemented using a Brooklyn module from Audinate.

The product firmware version number is assigned by Studio Technologies as an identifier when a firmware file is released that combines specific Model 5418 configuration information along with the Audinate-developed Dante operating firmware. The firmware for the Model 5418's Dante interface can be updated by way of an Ethernet connection using the Dante Updater software application that's provided as part of the Dante Controller software application.

The Dante firmware is the embedded software is used by the Brooklyn module for Dante interconnectivity. The version number shown is assigned by Audinate and can't be changed by Studio Technologies. It is incorporated into the Dante product firmware file (with the extension .dnt) that is released by Studio Technologies specifically for the Model 5418. As noted previously, this firmware, part of the Dante product firmware, can be updated by way of an Ethernet connection using the Dante Updater software application.

#### **Row Four**

This row has three front-panel menu pages that involve the management IP address and related parameters. One menu page is display-only and the other two can allow changes to be made.

**Current Management IP Address and Subnet Mask:** This menu page will show the IP address and subnet mask utilized by the Model 5418's internal management web server. This is the IP address and subnet mask value that's associated with the connection made to the Model 5418's management RJ45 jack that's located on the back panel. This IP address and subnet mask value can be assigned automatically using the DHCP protocol or, if a DHCP server is not available, using the IPv4 link-local protocol. (If the IP address shown is in the format of 169.254.x.x it was assigned using IPv4 link-local.) The management IP address can also be assigned with a manual (fixed or static) IP address. If no Ethernet connection has been made with this RJ45 jack, the text **No Ethernet Link** will be shown. Link-local will assign a subnet mask value of 255.255.0.0. The subnet mask value can also be manually assigned.

**Management IP Configuration:** This menu page allows the display and revision of the method that the Model 5418 uses to obtain a management IP

address, subnet mask, and manual gateway parameters. The choices are *Automatic* and *Manual*. Most importantly, the selected configuration impacts how the Model 5418 obtains the IP address that is used for accessing the management web server and associated menu webpages. This setting has no impact on how the Model 5418 obtains IP addresses for the Dante primary and Dante secondary Ethernet interfaces.

An arrow icon will show in the upper-right corner of this menu page to indicate that the setting can be changed. If the active management IP configuration method is not the desired one, press the Enter push-button switch located on the front panel. Use the left and right arrow buttons to select the desired method. (For clarity, the configuration choice that is currently active will have an asterisk (\*) at the end of its name.) Then again press the Enter button. The entry will be stored. To cause the Model 5418 to use a new setting requires that the unit be rebooted (restarted). This can be performed using another front-panel menu page, a selection in one of the management webpages, or by power cycling the unit.

Selecting the *Automatic* setting causes the Model 5418 to use DHCP or, if DHCP is not available, the IPv4 link-local protocol to establish the IP address for the management port. Even if the IP address was established using link-local the DHCP protocol will remain active. In this case, approximately every 30 seconds the Model 5418's firmware will check for the presence of a DHCP server. If one becomes available then an IP address will be requested and, when obtained, it will automatically replace the IP address that was previously established by link-local.

The *Manual* setting allows IP address, subnet mask, and manual gateway values to be manually entered. This can be useful when a fixed or static addressing scheme has been established. In this way, a designated IP address and related parameters can be entered along as needed.

Note that to minimize the chance of losing access to the management web server, restoring the Model 5418's default configuration values will not change the currently selected IP address configuration choice.

### **Manual Management IP Address and Subnet Mask:**

This menu page shows the stored manual IP address and subnet mask associated with the management web server. This address and subnet mask value have nothing to do with the IP address and subnet mask value utilized by the Dante primary and Dante secondary Ethernet interfaces. They will be utilized only when the manual mode has been selected for the management IP address configuration.

When the IP address configuration has been selected for *Automatic*, these fields cannot be changed and a lock icon will show in the upper-right corner of the display. Whenever the IP address configuration is selected for *Manual*, the manual IP address and subnet mask values can be modified as desired. This will be indicated by an arrow icon that will show in the upper-right corner of the display. To start the process, press the Enter pushbutton switch on the front panel. An icon with a wrench and screwdriver will show to indicate that an edit is in process. To select a specific IP address, use the left and right arrow pushbutton switches to select the specific digits to be modified. Press the up and down arrow pushbuttons to select the desired number. The standard dot-decimal notation is used to display and revise the IP address. Once all the desired changes have been made press the Enter button to store them. Follow the same process to change the subnet mask value.

To cause the Model 5418 to use a new IP address and/or subnet mask settings requires that the unit be rebooted (restarted). This can be performed using another front-panel menu page, using a function on a management webpage, or by power cycling the unit. Restoring the Model 5418 to its default values will not change the stored manual IP address.

### **Row Five**

Row five contains five menu pages. Four of the menu pages are display-only and provide information about the specific Model 5418, including its Dante product name, hardware serial number, MCU and FPGA firmware (embedded software) versions, and connected power sources. A fifth menu page that allows the system to be rebooted (restarted).

**Product Name, Dante Name, and Hardware Serial Number:** This menu page shows the name of the product, the Dante device name, and the unit's hard-

ware serial number. The top line shows the product name (**Model 5418**) and can't be changed. The second line shows the Dante device name. The default name consists of the text **ST-M5418-** followed by the last part of the Dante interface's MAC address. It can be changed using the Dante Controller software application so what actually shows will be application dependent. Each device in a Dante application must have a unique Dante device name. The routing of audio channels is based on the Dante device name of each Dante device in an application. The third line shows the hardware serial number which consists of five numeric digits. It is unique for each Model 5418 unit. It is assigned at the factory and can't be changed.

### **Main MCU and Secondary MCU Firmware Versions:**

This menu page shows the version numbers of the Model 5418's Main MCU and Secondary MC firmware. These firmware files can be updated using a USB flash drive. Update details are provided in the Technical Notes section.

**FPGA Firmware Version:** This menu page shows the version number of the Model 5418's FPGA (field-programmable gate array) integrated circuit firmware. This firmware can be updated using a USB flash drive. Update details are provided in the Technical Notes section.

**AC Mains Input and DC Input Status:** This menu page shows status of the AC mains input and DC input power sources. Each can be connected to power the unit. The text **Connected** or **Disconnected** will be present. If the text **Connected** shows for both, the AC mains input will be powering the Model 5418 and the DC will be serving as a backup source.

**Reboot Device:** This menu page can allow the Model 5418 to be rebooted (restarted). This can be useful to force the Model 5418 to utilize revised management and Dante interface configuration changes. It will also cause the Dante interface to reboot. If the front panel control configuration has been selected for *View/Edit*, an arrow icon will show in the upper-right corner of this menu. This will allow a reboot to be initiated. If a lock icon shows then a reboot will not be possible. Assuming that reboot is possible, to start the process press the Enter pushbutton on the unit's front panel. This will lead to a confirmation page

being shown. Use the left and right arrow pushbutton switches to select the desired action. The choices are to cancel or to confirm. Press the Enter pushbutton switch to select the highlighted action. The Model 5418 will then immediately commence the selected action. After performing a system reboot (restart), 20 to 60 seconds may be required for the Model 5418's operation to fully restore. During this time period the management Ethernet port will briefly disconnect and then reconnect.

## STcontroller Support

Several key Model 5418 operating parameters can be monitored and adjusted in real-time using the STcontroller software application. Eight “virtual” meters allow the level of the mic/line input channels to be monitored in near-real-time. STcontroller also provides a means of directly accessing the Model 5418’s management webpages. In addition, the version numbers of the unit’s firmware can be viewed. The configuration of a specific Model 5418 can be saved, in XML format, onto the personal computer associated with STcontroller. A configuration file can also be loaded into the associated Model 5418.

### Installing STcontroller

STcontroller is available free of charge on the Studio Technologies’ website ([studio-tech.com](http://studio-tech.com)). Versions are available that are compatible with personal computers running selected versions of the Windows® and macOS® operating systems. If required, download and install STcontroller onto a designated personal computer. This personal computer must be on the same local area network (LAN) and subnet as the Model 5418 unit that is to be configured and/or monitored. Immediately after starting STcontroller the application will locate all of the Studio Technologies’ devices that it can control. The one or more Model 5418 units on the network will appear in STcontroller’s device list. Use the *Identify* icon to allow easy recognition of a specific Model 5418 unit. Double-clicking on a device name will cause the associated configuration and display menu to appear.

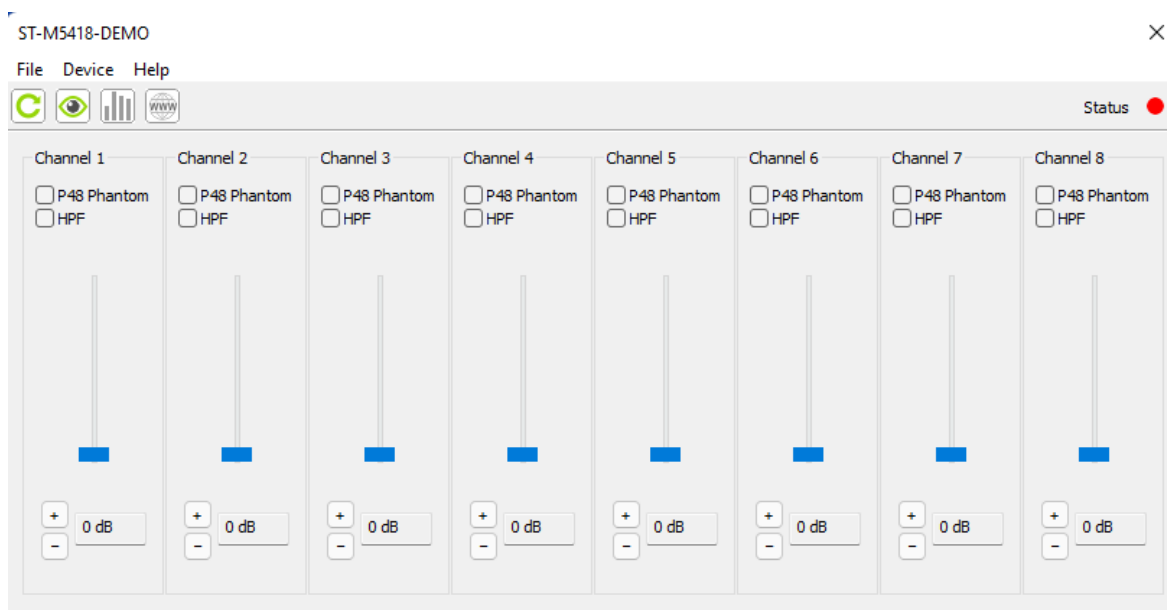

### Channel Names

STcontroller’s graphics page that supports the Model 5418 shows eight sections, one for each mic/line input channel. Text on the top of each section will help to identify a specific channel. Depending on the version of main MCU firmware loaded into the Model 5418, either the text **Channel** and then a number **1-8** will show, or the Dante channel name will be shown. If the latter is present, the full name may be truncated as the number of characters that can be shown is less than the maximum number of characters in a Dante channel name.

### Channel Configuration

STcontroller’s support for the Model 5418 allows three parameters associated with each of the eight mic/line input channels to be displayed and revised. A status box will show the current status of the P48 microphone power source. Use a computer mouse to click on the box should a change in the status of the P48 function be desired. The status of each channel’s high-pass filter (HPF) function is also shown. A computer mouse can be used to change the HPF status if desired. The gain of the microphone preamplifier associated with each mic/line input channel is

shown in two ways. A text box shows the gain directly in dB. A slider graphic also indicates the gain of the preamplifier in relation to the minimum and maximum value. The gain of each preamplifier can be changed using either of two methods. Two icons, labeled **+** and **-** can be clicked using a computer mouse to revise the gain in pre-determined steps. The handle of the slider graphic can also be used by the computer mouse to adjust the preamplifier gain. The gain of the microphone preamplifier can be 0 dB to support connection of line-level input signals. It can also be selected over a range of 10 to 60 dB, in 1-dB steps, which is typically used for microphone signals.

### Level Meters

STcontroller allows the level of the eight mic/line input channels to be shown by way of graphics meters. By default, each time STcontroller is used to access a Model 5418 the level meter function is disabled. This is to limit the amount of Ethernet data traffic that flows between a Model 5418 unit and the computer running STcontroller. To enable audio metering use the computer mouse to click on the Audio Meter Enable icon. This action can be useful during configuration and performance confirmation, especially when adjusting the gain of the microphone preamplifiers. Unless absolutely necessary, the meter function should remain off when not needed so that network data traffic is minimized. STcontroller's level metering is considered to be semi-real-time. The way in which level data is sent from a Model 5418 to the STcontroller application can add one to two seconds of delay from an event occurring to what is shown. This should typically not be an issue but it's important to be aware of this condition. Also note that the meter display value is updated eight times per second.

### Accessing the Management Webpages

STcontroller's Model 5418 support allows a user to directly access the management webpages. This can be useful, eliminating the need to know the management port's IP address. (The management IP address can only be conveniently identified by viewing one of the Model 5418's front-panel display pages.) A "www" icon, named **Manage Device in Web Browser**, is located directly to the right of the level meter icon. Use this icon to invoke the personal

computer's browser and immediately connect to the management system's home webpage. The normal login process will then be used to access the various webpages.

### Identifying Hardware and Firmware

STcontroller allows detailed information about the Model 5418's hardware and firmware (embedded software) to be shown. From the **Device** tab, select **Version and Information** and a screen will appear. Review this screen for details.

### Saving and Loading a Model 5418 Configuration

For archiving, backup, or "cloning" purposes STcontroller allows a complete Model 5418 configuration to be saved in the form of an XML file. This file can then be loaded into the same Model 5418 unit as needed, or into another Model 5418 unit if desired. Clicking on the **Device** menu tab will provide access to the Save Configuration and Load Configuration functions.

## Technical Notes

### Dante IP Addresses

If the Model 5418's Dante interface has been configured in the Dante Controller application for Switched operation, by default the Model 5418's Dante primary Ethernet interface will attempt to automatically obtain an IP address and associated settings using DHCP (Dynamic Host Configuration Protocol). If a DHCP server is not detected, an IP address will automatically be assigned using the link-local protocol. This protocol is known in the Microsoft® world as Automatic Private IP Addressing (APIPA). It is also sometimes referred to as auto-IP (PIPPA). Link-local will randomly assign a unique IP address in the IPv4 format of 169.254.x.x. In this way, multiple Dante-enabled devices will connect together and automatically function, whether or not a DHCP server is active on the LAN. Even two Dante-enabled devices that are directly interconnected using an RJ45 patch cord should, by way of link-local, correctly acquire IP addresses and be able to communicate with each other. As previously discussed, using Dante Controller the Model 5418's Dante Ethernet IP address(es) and related network parameters can also be set for manual (fixed or static) operation.

If the Model 5418's Dante interface has been configured in Dante Controller for Redundant operation, by default both the Model 5418's Dante primary and Dante secondary Ethernet interfaces will attempt to automatically obtain IP addresses and associated network settings using DHCP. If DHCP is not available, link-local IP addresses will be assigned. Link-local will assign an IP address in the format of 169.254.x.x for Dante primary and 172.31.x.x for Dante secondary. If automatic assignment of IP addresses is not desired, each interface can be individually configured using Dante Controller to use a manual (fixed or static) IP address and related network parameters.

The specific IP address assigned to each of the Model 5418's Dante interfaces can be identified using several methods. The Dante Controller application will directly show the network parameters of the primary and, if utilized, secondary Ethernet interfaces. Another means is to utilize the Model 5418's network webpage to directly show the IP addresses assigned to the Dante primary and, if utilized, Dante secondary Ethernet ports. The Model 5418's front-panel menu system can also be selected to show the Dante primary IP address.

## Optimizing Dante Network Performance

For best Dante audio-over-Ethernet performance a local-area-network (LAN) that supports VoIP QoS (voice-over-internet-protocol quality of service) capability is recommended. This can typically be implemented on virtually all contemporary managed Ethernet switches. There are even specialized switches that are optimized for entertainment-associated applications. This includes the AV Series of Ethernet switches from Netgear. Refer to the Audinate website ([audinate.com](http://audinate.com)) for details on how to optimize a network for Dante applications.

## Management IP Address

By default, the Model 5418's management Ethernet interface address configuration is set for automatic. In this way, it will attempt to automatically obtain an IP address and associated settings using DHCP. If a DHCP server is not detected an IP address will automatically be assigned using the link-local protocol in the IPv4 range of 169.254.x.x. Using the

network configuration webpage provided as part of the Model 5418's management system, the management Ethernet IP address and related network parameters can also be set for a manual (fixed or static) configuration.

## Firmware Update Procedure

It's possible that updated versions of the three firmware (embedded software) files that are utilized by the Model 5418's two microcontrollers (MCU) and one FPGA (field-programmable gate array) integrated circuit will be released to add features or correct issues. Refer to the Studio Technologies' website for the latest firmware files. The Model 5418 has the ability to load revised files into non-volatile memory by way of a standard USB flash drive.

The Model 5418 implements a USB host function and provides access by way of a type A receptacle located on the unit's back panel. The Model 5418 updates its firmware using three files. The Main MCU firmware is named **M5418.bin**. The name of the Secondary MCU firmware depends on the serial number of the unit. If the serial number is M5418-00151 to M5418-00362 the file name will be **M5x18sec.bin**. If the serial number is M5418-000363 and later the file name will be **M5418secvXrXX.sts** where "XrXX" will represent the revision level contained within the file. The name of the FPGA firmware is **SFB.bit**.

The update process begins by preparing a USB flash drive. The flash drive doesn't have to be empty (blank) but must be in the personal-computer-standard FAT32 format. One, two, or all three of the firmware files can be automatically loaded at the same time. On the flash drive's root folder, save the desired new firmware files, ensuring that



**Figure 9. Detail of Model 5418 back panel showing firmware update USB receptacle**

the required names are specified. The file name for the Main MCU firmware must be **M5418.bin**. If the unit's serial number is M5418-00151 to M5418-00362, the file name for the Secondary MCU firmware will be **M5x18sec.bin**; the file name will be **M5418secvXrXX.sts** if the serial number is M5418-00363 and later. For this file "XrXX" will represent the revision level contained within the file. The file name for the FPGA firmware must be **SFB.bit**. Be certain to use the eject command to ensure that the file is correctly stored on the USB flash drive.

Studio Technologies will supply each firmware file inside a .zip archive file. While the firmware file inside of the zip file will adhere to the naming convention required by the Model 5418, the name of the zip file itself will include the file's version number. For example, a file named **M5418v3.07MCU.zip** would indicate that version 3.07 of the Main MCU firmware (**M5418.bin**) is contained within this zip file.

Once the USB flash drive is inserted into the USB receptacle, located on the back panel, the Model 5418 must be powered off and again powered on. At this point, the files will automatically load. The precise steps required will be highlighted in the next paragraphs.

To install new firmware files, follow these steps:

1. Remove power from the Model 5418. This will entail either removing the AC mains power connector or removing the external source of 12 volts DC. (Both must be disconnected if dual powering has been implemented.)
2. Locate the USB receptacle, labeled Firmware Update, on the Model 5418's back panel. Directly adjacent to the USB receptacle is a small hole that provides visual access to a green LED indicator.
3. Insert the prepared USB flash drive into the USB receptacle.
4. Apply power to the Model 5418. Power can be provided by connecting AC mains or a source of 12 volts DC.
5. After a few seconds the Model 5418 will run a "boot loader" program that will automatically load and save the new firmware files that are present on the USB flash drive. The update process can range from approximately 15 seconds to approximately 45 seconds, depending on which of the files are going to be updated. While files are being loaded the green LED, located adjacent to the USB receptacle, will flash slowly. Once the entire loading process has completed the Model 5418 will restart using the newly saved Main MCU, Secondary MCU, and/or FPGA firmware files.
6. At this time the Model 5418 is functioning with the newly loaded firmware and the USB flash drive can be removed. To be conservative, remove the power source first and then remove the USB flash drive.
7. It's a good idea to confirm that the desired firmware has been loaded and that the Model 5418's Main MCU, Secondary MCU, and FPGA firmware versions are operating as expected. Menus associated with the front-panel display can be used to observe the version numbers. The system webpages can also be utilized.

Note that upon power being applied to a Model 5418 if a connected USB flash drive doesn't have a correct file in its root folder no harm will occur. Upon power up, the green LED, located adjacent to the USB receptacle, will flash on and off rapidly for a few seconds to indicate that a valid file has not been found. After this warning, normal operation using the unit's existing firmware will begin.

## Dante Firmware Update

As previously discussed, the Model 5418 implements Dante connectivity using the Brooklyn module from Audinate. The firmware (embedded software) residing in the Brooklyn module can be updated using one of the Model 5418's Dante Ethernet ports. The Dante Controller software application can be used to determine the version of the firmware (embedded software) that resides in the Brooklyn module. The System Information webpage provided by the Model 5418's web server can also be used to identify the firmware version. The Dante Controller software

application includes an automated method of updating the Brooklyn module's firmware. It's called Dante Updater and is very easy to use. The Dante Controller application is available, free of charge, on the Audinate website [audinate.com](http://audinate.com).

The latest Model 5418 Dante firmware file, with an extension of .dnt, is available on the Studio Technologies' website as well in Audinate's product library database. The latter allows the Dante Updater software application that is included with Dante Controller to automatically update the Model 5418's Dante interface.

## Restoring Default Settings

A command in the System webpage provided by the Model 5418's web server allows most of the configuration settings to be restored to their factory default values. This can be useful but must be used with caution. Any customization made to the Model 5418's configuration will be lost. This can be offset in a positive way by returning the Model 5418 to a known configuration, a point that might aid in troubleshooting an issue. Refer to Appendix F for a list of the default values.

## Lost User Name and/or Password

As is covered in detail in other sections, gaining access to the Model 5418's configuration menu webpages requires entering the correct user name and password. If the default entries, both of which are **guest**, are stored for use, they will show on the Login menu webpage. Pressing the Log In button on that webpage will then access the Home configuration webpage. If either or both the user name and the password have been configured to be something other than **guest** (the default), nothing will show in the fields associated with the Login menu webpage.

If knowledge of the stored user name and/or password is "lost," the Model 5418 includes a "back door" to allow access. As a security measure physical access to the unit is required to utilize that access method; there is no means to access the unit via an Ethernet port without knowledge of the user name and password. The exact process of accessing the Model 5418's configuration webpages without knowledge of the user name and/or password is detailed in Appendix G.

## Specifications

### Network Audio Technology:

**Type:** Dante audio-over-Ethernet

**AES67-2018 Support:** yes, selectable on/off

**Dante Domain Manager (DDM) Support:** yes

**Ethernet Interface Configuration:** Switched or Redundant

**Bit Depth:** up to 24

**Sample Rates:** 44.1, 48, and 96 kHz, selectable

**Number of Transmitter (Output) Channels:** 8

**Number of Receiver (Input) Channels:** 8

**Dante Audio Flows:** 32 transmitter, 32 receiver

### Network Interfaces:

**Qty:** 3; Dante primary, Dante secondary, and management

**Type:** 1000BASE-T (Gigabit Ethernet (GigE)) per IEEE 802.3ab (100 Mb/s also supported but not recommended for optimal performance)

**NIC Status LEDs:** one link and one activity for each Ethernet interface

### Mic/Line Inputs: 8

**Compatibility:** dynamic, ribbon, or phantom-powered mics; mic/line-level sources

**Type:** analog, electronically balanced, capacitor coupled

**Impedance – Mic Setting:** 3.0 k ohms, nominal

**Impedance – Line Setting:** 6.4 k ohms, nominal

**Gain:** 0 dB (line), 10-60 dB in 1-dB steps

**Maximum Level:** +24 dBu, 0 dB gain selected (results in Dante output level of 0 dBFS)

**EIN:** –126 dBu, 22 kHz bandwidth, 49 dB gain, 150 ohm source resistance

**Dynamic Range:** >117 dB, 0 dB gain, A-weighted

**Distortion (THD+N):** <0.001% (–101 dB) at –1 dBFS, 40 dB gain, 22 kHz bandwidth

**Frequency Response:** +0.0/–0.1 dB, 20 Hz to 22 kHz, HPF off

**High-Pass Filter (HPF):** –6 dB at 75 Hz, 18 dB per octave, on/off selectable per channel

**Phantom Power:** P48 per IEC 61938:2013 standard, +46 volts DC nominal, on/off selectable per channel

**Metering:** part of OLED display function

**Status LEDs per Input Channel:** 3; P48, HPF, and input channel selected

**Remote Configuration Capability:** preamplifier gain, P48 phantom power on/off status, and high-pass filter (HPF) on/off status (uses STcontroller software application)

### Analog Outputs: 8

**Type:** line-level, electronically balanced, capacitor coupled, intended to drive balanced or unbalanced loads of 2 k ohms or greater

**Source Impedance:** 200 ohms

**Nominal Level:** +4 dBu, reference –20 dBFS, adjustable  $\pm 20$  dB in 1-dB steps

**Maximum Level:** +24 dBu

**Dynamic Range:** >115 dB, A-weighted

**Distortion (THD+N):** 0.001% (–100 dB), reference 1 kHz, measured at +23 dBu output (–1 dBFS input)

**Frequency Response:**  $\pm 0.1$  dB, 6 Hz to 20 kHz

### Audio Monitor:

**Source:** mic/line inputs or analog outputs, selectable as monaural or stereo

**Metering:** part of OLED display function

### Headphone Output:

**Type:** stereo (dual-channel)

**Compatibility:** intended for connection to stereo headphones with nominal impedance of 100 ohms or greater

**Maximum Output Voltage:** 4.9 volts RMS, 1 kHz, 150 ohm load

**Frequency Response:** +0/–1.4 dB, 20 Hz to 20 kHz

**Distortion (THD+N):** 0.005%

**Dynamic Range:** >100 dB

### Front-Panel Display: OLED

**Software Updating:** USB flash drive supports updating of application and FPGA firmware (embedded software); Dante interface updated via Ethernet interface

### Power Sources:

**AC Mains:** 100 to 240 V, 50/60 Hz, 20 W maximum

**DC:** 10 to 18 V, 1.5 A maximum at 12 V, 1.6 A maximum at 10 V

### Connectors:

**Mic/Line Inputs:** 3-pin female XLR

**Analog Outputs:** 25-pin female D-subminiature (DB-25F), AES59-2012 compliant

**Ethernet:** RJ45 jack

**Headphone Output:** 3-conductor ¼-inch jack

**USB:** type A receptacle (used only for application firmware updates)

**DC Input:** 4-pin male XLR (pin 1 negative, pin 4 positive)

**AC Mains Input:** 3-blade, IEC 320 C14-compatible (mates with IEC 320 C13)

**Environmental:**

**Operating Temperature:** 0 to 50 degrees C (32 to 122 degrees F)

**Storage Temperature:** -40 to 70 degrees C (-40 to 158 degrees F)

**Humidity:** 5 to 95%, non-condensing

**Altitude:** not characterized

**Dimensions – Overall:**

19.0 inches wide (48.3 cm)

1.72 inches high (4.4 cm)

7.8 inches deep (19.8 cm); 8.3 inches (21.1 cm) overall

**Mounting:** one space (1U) in a standard 19-inch rack

**Weight:** 3.5 pounds (1.6 kg)

Specifications and information contained in this User Guide subject to change without notice.

## Appendix A – Network Configuration Examples

### ONE LAN – SWITCHED DANTE

MODEL 5418 NETWORK INTERFACE  
CONFIGURED FOR SWITCHED OPERATION

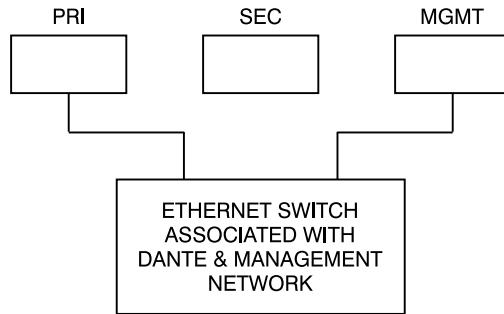

### ONE LAN – SWITCHED DANTE

MODEL 5418 NETWORK INTERFACE  
CONFIGURED FOR SWITCHED OPERATION

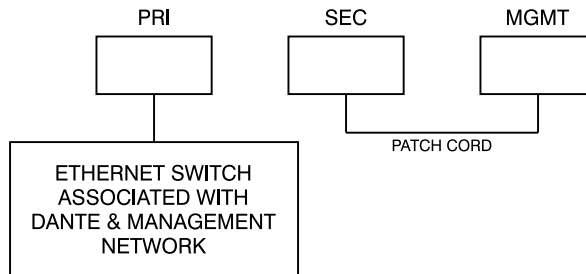

### TWO LANs – SWITCHED DANTE

MODEL 5418 NETWORK INTERFACE  
CONFIGURED FOR SWITCHED OPERATION

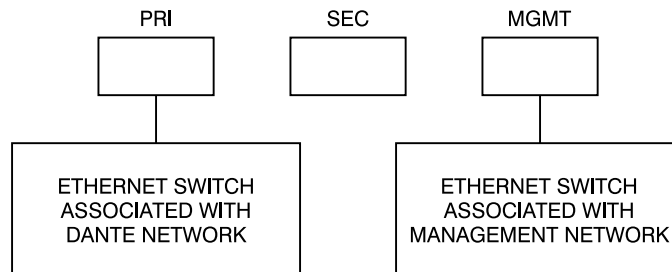

**TWO LANs – REDUNDANT DANTE**  
MODEL 5418 NETWORK INTERFACE  
CONFIGURED FOR REDUNDANT OPERATION

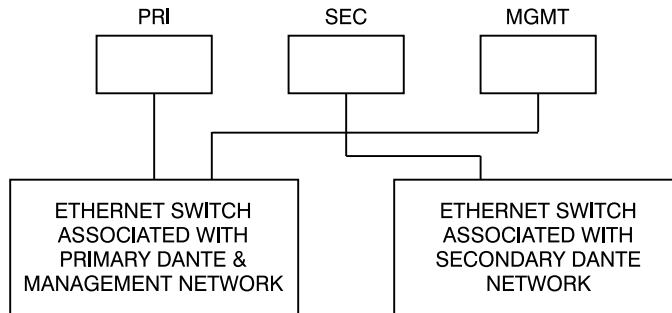

**TWO LANs – REDUNDANT DANTE**  
MODEL 5418 NETWORK INTERFACE  
CONFIGURED FOR REDUNDANT OPERATION

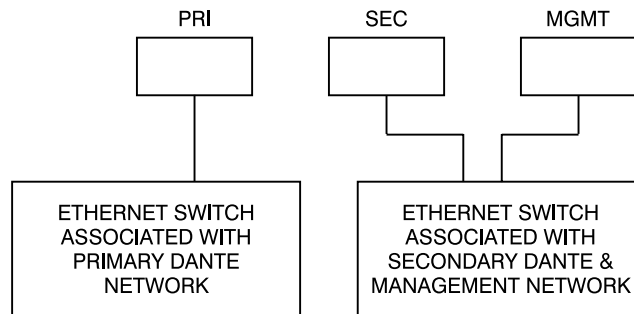

**THREE LANs – REDUNDANT DANTE**  
MODEL 5418 NETWORK INTERFACE  
CONFIGURED FOR REDUNDANT OPERATION

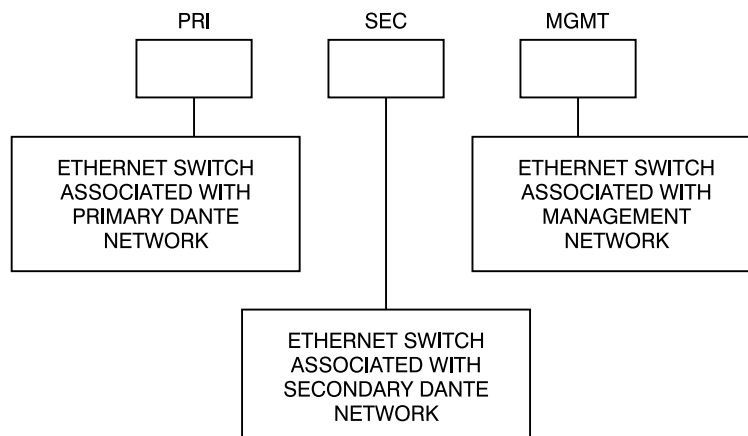

## Appendix B – Connection Pin-Out Charts

### Model 5418 Analog Outputs

#### Connections for Analog Output Channels 1-8

Channel	High (+)	Low (-)	Shield
1	24	12	25
2	10	23	11
3	21	9	22
4	7	20	8
5	18	6	19
6	4	17	5
7	15	3	16
8	1	14	2

#### Notes:

- 1) Connector type is 25-pin female D-subminiature (DB-25F). Installer must provide male (DB-25M). Connectors use 4-40 UNC threaded inserts for locking with mating plugs.
- 2) Wiring schemes follow AES59-2012 convention. Standard TASCAM-type wiring harnesses are typically compatible (locking hardware requires 4-40 UNC screw threads).

## Appendix C – Default Dante Channel Names

### Dante Transmitters (Outputs)

Number	Name	Description
1	Ch1	From Mic/Line Input Channel 1
2	Ch2	From Mic/Line Input Channel 2
3	Ch3	From Mic/Line Input Channel 3
4	Ch4	From Mic/Line Input Channel 4
5	Ch5	From Mic/Line Input Channel 5
6	Ch6	From Mic/Line Input Channel 6
7	Ch7	From Mic/Line Input Channel 7
8	Ch8	From Mic/Line Input Channel 8

### Dante Receivers (Inputs)

Number	Name	Description
1	Ch1	To Analog Output Channel 1
2	Ch2	To Analog Output Channel 2
3	Ch3	To Analog Output Channel 3
4	Ch4	To Analog Output Channel 4
5	Ch5	To Analog Output Channel 5
6	Ch6	To Analog Output Channel 6
7	Ch7	To Analog Output Channel 7
8	Ch8	To Analog Output Channel 8

## Appendix D – Source Selection Overview

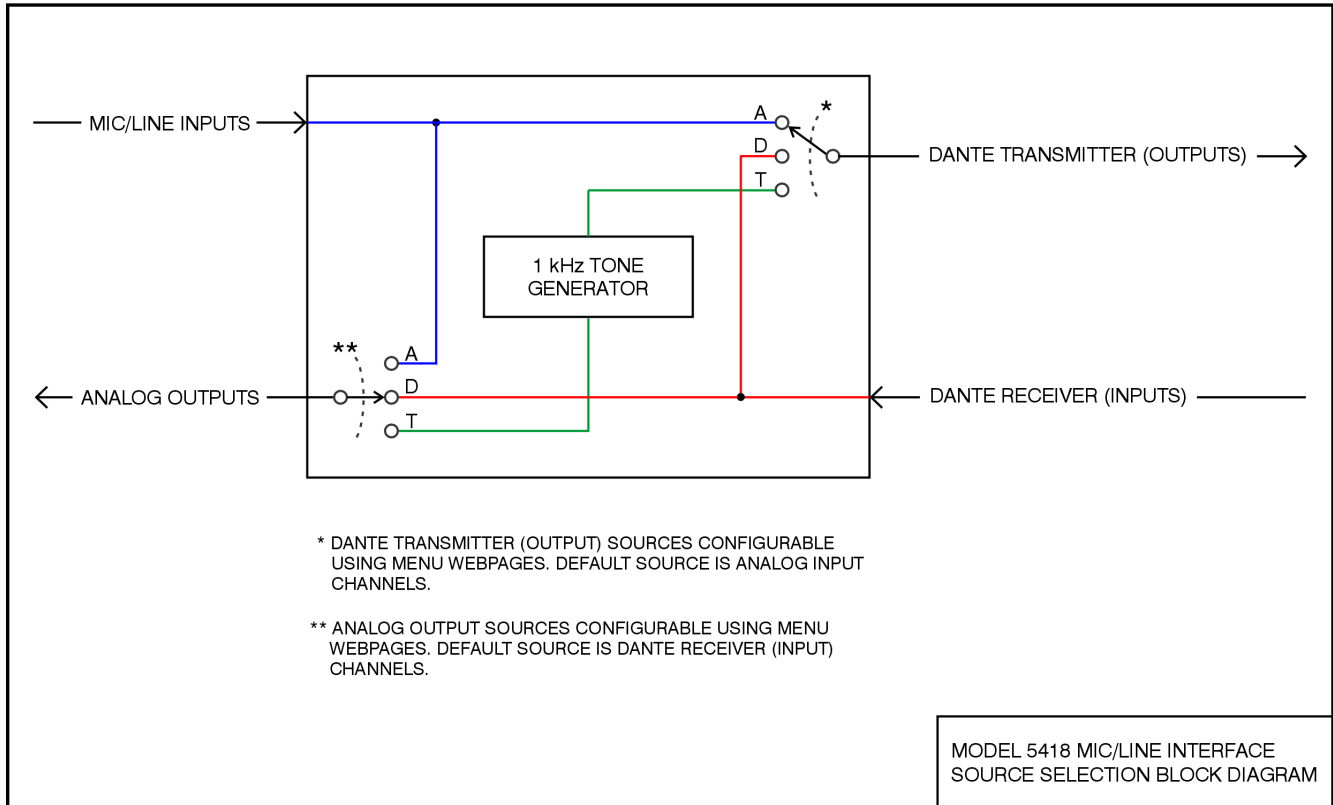

# Appendix E – Front-Panel Menu Structure

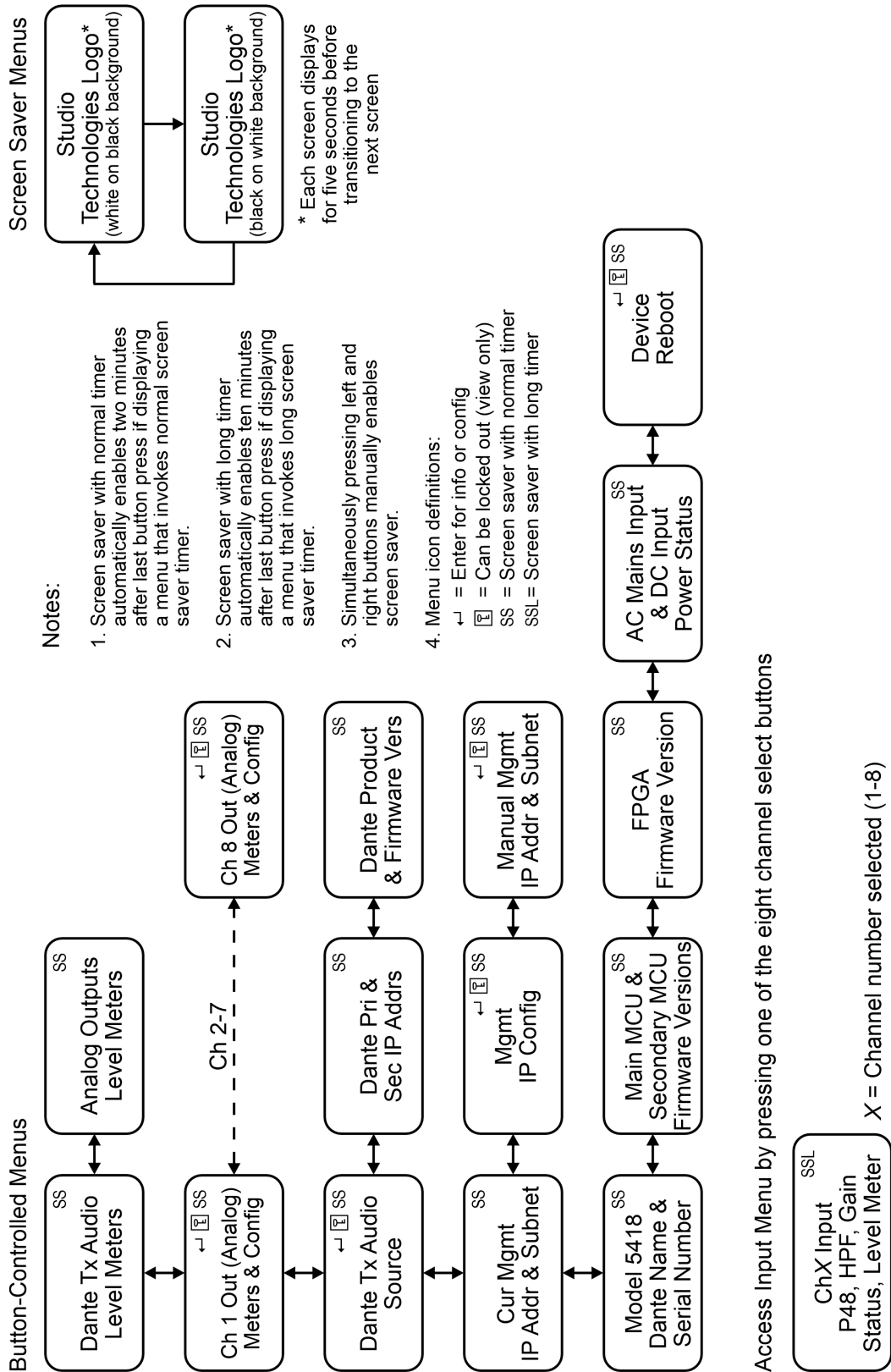

## Appendix F – Default Configuration Values

### **Analog Inputs:**

Level Adjustments (Channels 1-8): 0.0 dB  
Dante Transmitters Source: Analog Inputs  
Dante Transmitter 8 Source: Analog Input 8

### **Analog Outputs:**

Level Adjustments (Channels 1-8): 0.0 dB  
Analog Outputs Source: Dante Receivers

### **Network - Management Interface:**

IP Address Configuration: Automatic  
Manual IP Address: 192.168.1.12  
Subnet Mask: 255.255.255.0  
Gateway IP Address: 192.168.1.1

### **Access:**

Front Panel Control: View/Edit  
User Name: guest  
Password: guest

## Appendix G – Accessing the Unit when User Name and/or Password are Not Known

Follow this procedure to access the Configuration menu webpages if the user name and/or password are not known.



1. Remove power from the Model 5418.
2. Press and hold the left arrow and Enter buttons.
3. While continuing to hold the two buttons apply AC Mains or 12 volts DC power.
4. Continue to hold the two buttons and allow the Model 5418 to start. The Status LEDs on the front panel will first light green then light red in their start-up sequence.
5. Once the Status LEDs have completed their start-up sequence release the two buttons.
6. Use a web browser to access the Model 5418's Configuration menu webpages. The management port's IP address to use is shown in the current management IP address page on the front-panel display. Pressing the Enter button will cause the current management IP address page to immediately show on the front-panel display.
7. From the Home webpage select the Login menu webpage tab. Leave the user name and password fields empty and click the Log In button. This will allow access to the Configuration menu selections. At this point your web browser should show the Model 5418's Home webpage.
8. Navigate to the Access menu. From this webpage you will be able to view the stored user name. You will not be able to view the previously saved password. Enter and confirm a new password. Henceforth, to access the Model 5418's Configuration menu will require the use of the stored user name and password.