

Model 5412

AUDIO INTERFACE

User Guide

Issue 4, April 2026

This User Guide is applicable for serial numbers M5412-01-00151 and later with Main Firmware 2.03 and later M5412-02-00151 and later with Main Firmware 2.03 and later Dante Firmware version 5.1.0 (Brooklyn 3 v4.3.1.8) and later

Copyright © 2026 by Studio Technologies, Inc., All rights reserved
studio-tech.com

This page intentionally left blank.

Table of Contents

Revision History.....	4
Introduction.....	5
Installation	8
Dante Configuration.....	12
Model 5412 Configuration	13
Operation.....	32
Technical Notes	37
Specifications	41
Appendix A – Network Configuration Examples	43
Appendix B – Connection Pin-Out Charts	45
Appendix C – Default Dante Channel Names	46
Appendix D – Source Selection Overview.....	47
Appendix E – Front-Panel Menu Structure.....	48
Appendix F – Factory Default Values	49
Appendix G – Accessing the Unit when User Name and/or Password are Not Known ...	50

Revision History

Issue 4, April 2026:

- Documents factory default changes to *Redundant Dante*.

Issue 3, December 2022:

- Documents revised Network and System management webpages.

Issue 2, September 2021:

- Revises format of document. Incorporates menu page screen captures in-line with text.

Issue 1, May 2021:

- Initial release.

Introduction

The Model 5412 Audio Interface provides a simple yet high-performance means of interfacing line-level analog signals with applications that utilize Dante® audio-over-Ethernet media networking technology. The Model 5412 is available in two versions, one with 8 input and 8 output channels and the other with 16 input and 16 output channels.

Analog sources can be connected to the unit, then output in the digital domain by way of a Dante interface. Digital audio signals, which also arrive by way of Dante, are converted to analog and can be output as balanced line-level signals. For application flexibility and troubleshooting, configuration choices allow selection of the audio sources used by the Dante transmitter and analog output channels. This provides digital and analog loopback and test tone capability.

The Model 5412 is a fully professional product that offers the audio quality, features, and reliability required by 24-hour on-air and commercial applications. The analog inputs and analog outputs use 25-pin D-subminiature connectors for easy interfacing with balanced and unbalanced sources and destinations.

The line-level analog audio input signals are converted to PCM digital and transported via a Dante interface. Using the Dante Controller software application, digital audio signals can be routed (subscribed) to the Model 5412 via the Dante interface.

The Model 5412 provides three Gigabit Ethernet (GigE) network interfaces, two to support Redundant Dante operation and the third for accessing the management menu system. To meet the latest interoperability standard, the Model 5412's Dante implementation supports AES67-2018. The unit also supports the Dante Domain Manager™ (DDM) software application. An integrated web server allows fast and flexible monitoring and configuration of the unit's networking and audio performance. Front-panel

LED indicators, a backlit LCD display, and push-button switches provide users with direct access to key operating parameters.

The Model 5412 can be powered by 100-240 V, 50/60 Hz mains or a source of 12 volts DC. Both can be simultaneously connected to provide Redundant operation. The unit's lightweight enclosure mounts in one space (1U) of a standard 19-inch rack. Industry-standard connectors are used for the analog input, analog output, Ethernet, DC power, and AC mains interconnections.

Dante audio-over-Ethernet has found wide acceptance as an audio “backbone” due to its ease of use, interoperability, excellent audio quality, and wide adoption by a large number of equipment manufacturers. The Model 5412 can serve as an “edge” device for Dante network implementations, providing high-performance line-level analog input and output resources in a compact, cost-effective package. The unit can also serve as a general-purpose audio “tool” to help extend Dante capabilities to facilities and applications that were initially implemented to support signals in the analog domain.

Dante Audio-over-Ethernet

Digital audio data associated with the Model 5412 is interfaced with one or two local area network(s) using Dante audio-over-Ethernet media networking technology. Status LEDs provide a real-time indication of Dante and LAN performance. The signals associated with the Model 5412's analog input channels are converted to digital and can be routed to Dante transmitter (output) channels on the unit's Dante interface. Transmitter (output) channels from Dante-enabled devices can be assigned to the Model 5412's Dante receiver (input) channels using the Dante Controller software application. These input signals can be converted into analog, then sent to the analog output circuitry.



Figure 1. Model 5412 Audio Interface front view

A major benefit of using Dante is its ability to use any standard Ethernet network implementation, including commonly available switches, to directly transport professional audio signals. The Model 5412 supports digital audio signals with a bit depth of up to 24 and a sample rate of 44.1, 48, 88.2, and 96 kHz. These sample rates were selected for optimal support of broadcast, production, industrial, and commercial applications.

Network Ports

Using the Dante Controller software application, the Model 5412's two Dante Ethernet ports can be selected to operate in either the Switched or Redundant mode. In the Switched mode, a single Ethernet connection is used for interconnection with other Dante-compliant devices. The second Model 5412 Dante Ethernet port can be used to interface with another piece of network equipment. In the Redundant mode, independent Ethernet connections are made to the unit's two Ethernet ports implementing Dante's Redundant network capability.

The Model 5412's third Ethernet port will always be used to access the management webpages. This port can be connected to an independent network that some facilities implement for equipment monitoring and maintenance purposes. The unit's management port can also be connected to the network that is being used for Dante. It would have a unique IP address and not interact with the Dante audio data.

Applications

Two versions of the Model 5412 are available, identified using the suffixes -01 and -02. The Model 5412-01 provides 8 line-level analog inputs and 8 line-level

analog outputs. The Model 5412-02 provides 16 line-level analog inputs and 16 line-level analog outputs. Both Model 5412 versions feature an optimized set of LED indicators, a graphics display, and push-button switches that make them simple and intuitive to use. Rack-mounted in one space "1U" of a standard 19-inch equipment rack, the units are appropriate for use in fixed locations, serving the needs of systems associated with post-production, content distribution, education, commercial, and government facilities. Their lightweight enclosure also makes them suitable for mobile and field uses.

Both Model 5412 versions units can serve as general-purpose analog-to-Dante/Dante-to-analog interface devices. Each is suitable for use in demanding on-air broadcast and live-event applications that require solid audio performance and reliable operation. And simple troubleshooting and performance confirmation is supported with the unit's flexible source selection capability.

A special function allows multiple Model 5412 analog inputs to be unity-gain mixed (combined or summed) and then output by way of a single Dante transmitter (output) channel. The mixing function is performed in the digital domain by way of a high-speed programmable logic (FPGA) device. Configuration choices allow selection of the specific input channels that are to be summed. With the Model 5412-01, Dante transmitter (output) channel 8 can use a single analog input channel, or a mix of up to all eight of the analog inputs as its audio source. The Model 5412-02 provides even more flexibility, allowing Dante transmitter (output) channels 15 and 16 to utilize, if desired, some or all of the 16 analog input channels as their audio signal sources.



Figure 2. Model 5412-01 Audio Interface back view



Figure 3. Model 5412-02 Audio Interface back view

This analog input channel mixing capability was specifically included to support intercom applications that would previously have utilized the RTS® Model MDA-100 Mixing Distribution Amplifier. In the pre-Dante days, an RTS matrix intercom system application might mix, using the MDA-100, the analog intercom “talk” outputs from multiple camera control units (CCUs), sending the result to a single ADAM® analog input port. And an analog audio output port on the ADAM matrix would use the MDA-100’s analog audio distribution amplifier (DA) capability to distribute the signal to the “listen” inputs on the multiple CCUs.

However, this situation changed when RTS matrix intercom systems began to include the Dante-compatible OMNEO® interfaces. This required a new method of interfacing the CCUs’ analog intercom capability with the digital audio-over-Ethernet OMNEO ports. A Model 5412 unit, utilizing its analog input mixing capability, can directly support these CCU intercom interfacing applications. The analog “talk” audio sources from multiple CCUs can be combined and output as a single Dante transmitter (output) channel. This channel would then be subscribed (routed) to an OMNEO receiver (input) port. And the analog outputs of a Model 5412 can easily provide a distribution amplifier (DA) function. It can be achieved by subscribing (routing) a single OMNEO transmitter (output) channel to multiple Dante receiver (input) channels on a Model 5412. An analog output channel would be associated with each Model 5412 Dante receiver (input) channel. These analog outputs would then be connected to the “listen” inputs on associated CCU units. Using this simple deployment, a Model 5412 will allow a reliable, high-performance, and cost-effective CCU-to-matrix intercom interface to be achieved.

Analog Inputs

Depending on the version selected, the Model 5412 will provide either 8 or 16 analog inputs that are compatible with balanced or unbalanced line-level sources. The input signals are converted to digital, then output to one or two Ethernet network(s) via Dante. Compatible signal sources include audio consoles, wireless microphone receivers, broadcast playback equipment, and output ports on matrix intercom systems or related equipment.

The analog inputs are electronically balanced (differential), capacitor-coupled, and ESD (static) protected for reliable operation in demanding applications. Extensive filtering minimizes the chance that radio frequency (RF) energy will cause interference. The analog inputs are protected from damage should a moderate DC voltage be accidentally connected. These characteristics make the analog inputs suitable for use in studio and mobile facilities as well as field-deployed environments.

The audio performance of the Model 5412’s analog inputs is very good. Low-noise, wide dynamic-range circuitry ensures that audio quality is preserved. The audio signals are routed to high-performance analog-to-digital conversion (ADC) sections that support a range of sample rates and a bit depth of up to 24. A precision voltage-reference circuit helps the ADC circuitry perform highly accurate signal conversion. The audio signals, now in the digital domain, are packetized and prepared for transport over Ethernet networking.

Analog Outputs

The selected Model 5412 version will provide either 8 or 16 line-level analog output channels. The analog outputs are electronically balanced, capacitor-coupled, and ESD (static) protected. High-quality components, including the important digital-to-analog converters, are used to provide low-distortion, low-noise, and sonically excellent performance. Robust circuitry provides protection from damage should a moderate DC voltage be accidentally connected, something especially useful in broadcast applications. The analog outputs are compatible with virtually all balanced and unbalanced loads with an impedance of 2 k ohms or greater.

The Model 5412’s analog outputs have a maximum level of +24 dBu. This allows both compatibility and sufficient headroom in applications where digital audio signals with a nominal level of –20 dBFS need to translate into analog signals that have a nominal level of +4 dBu. For flexibility, a configuration menu choice allows the level of each analog output channel to be individually adjusted (“trimmed”) over a range of ±20 dB in 0.1-dB steps.

Flexible Source Configuration

For installation confirmation, system testing, and troubleshooting support, the Model 5412 provides a unique set of configuration choices. The audio signal sources associated with the Dante transmitter (output) channels and the analog output channels can each be selected, as a group, from three choices. The Dante transmitter (output) channels can have their audio source selected to be the Model 5412's analog line inputs, the Model 5412's Dante receiver (input) channels, or a low-distortion 1 kHz sine-wave tone. During normal operation the analog line inputs will be selected. Having the ability to enable a Dante digital loopback function can help confirm network performance and provide assistance during troubleshooting. The ability to have a 1 kHz tone present on all the Dante transmitter (output) channels can also prove useful.

The analog outputs can have their audio sources selected to be the Model 5412's Dante receiver (input) channels, the Model 5412's analog input channels, or a 1 kHz tone. In most cases, the Dante receiver (input) channels would be selected as the audio sources for the analog output channels. Having analog loopback capability can make confirmation of analog wiring a simple matter. Being able to have a 1 kHz tone present on all of the analog output channels can make it a simple matter to confirm operation of devices connected to the Model 5412's analog outputs.

Simple Installation

The Model 5412 uses standard connectors to allow fast and convenient interconnections. Multiple 25-pin female D-subminiature connectors are used to interface with the analog input and analog output signals. The unit connects to local area networks (LANs) using three RJ45 jacks. Multiple LEDs on the unit's back-panel display the status of the network connections. A detachable power cord can be used to connect a source of AC mains power. Alternately, a DC power source can be connected using a 4-pin XLR connector. The lightweight aluminum enclosure mounts in one space (1U) of a standard 19-inch rack enclosure.

Operating Power

The Model 5412 allows an AC mains source of 100-240 V, 50/60 Hz to be connected by way of a standard detachable mains power cord. It can also be DC powered using a 10-18 volt source that is connected via a broadcast-standard 4-pin XLR connector. If both AC and DC power sources are connected, the unit will be powered by the AC mains supply. Only if the AC mains source fails will a load be placed on the DC source. This allows a source of DC, typically an external power supply, to serve in a backup capacity. With this arrangement normal operation can continue even if AC mains power is lost.

Future Capabilities and Firmware Updating

The Model 5412 was designed so that its capabilities can be enhanced in the future. A USB connector, located on the unit's back panel, allows the application and FPGA firmware (embedded software) to be updated using a USB flash drive. The Model 5412 uses Audinate's Brooklyn interface module to implement Dante. The firmware in this module can be updated via the unit's Ethernet connections, helping to ensure that the Dante capabilities remain up to date. All software files and configuration parameters are stored in non-volatile memory.

Installation

In this section, the Model 5412 Audio Interface will be mounted in one space (1U) of an equipment rack. Ethernet network connections will be made. Analog audio input and output signals will be interconnected. AC mains and/or DC power will be connected.

Up to three Gigabit Ethernet data connections will be made to the Model 5412 using standard RJ45 patch cables. Connections will be made to the analog input channels using one or two 25-pin D-subminiature connectors. Connections to the analog output channels will be made using one or two additional 25-pin D-subminiature connectors

AC mains power can be connected to the Model 5412 by means of a detachable cord set that is compatible with the unit's 3-pin IEC 320 C14 inlet connector. Some applications may warrant connection to a source of nominal 12 volts DC which can

be made by way of a 4-pin XLR connector. The DC source can be used to power the Model 5412 or it can serve as a backup power source should AC mains be connected.

What's Included

The shipping carton contains one each of either a Model 5412-01 or Model 5412-02 and instructions on how to obtain an electronic copy of this guide. Also included in the shipping carton is a North-American-standard AC mains cord. For destinations outside of North America the local reseller or distributor should provide an appropriate AC mains cord.

Mounting the Model 5412

The Model 5412 Audio Interface requires one space (1U) in a standard 19-inch (48.3 cm) equipment rack. Secure the Model 5412 into the equipment rack using two mounting screws per side. As the Model 5412 does not contain a fan or other noise-producing source, it can be located within a room or other structure where audio monitoring is going to take place. Select a location that is convenient for making connections to the Ethernet interfaces and analog audio inputs and outputs. Twisted-pair (UTP) Ethernet has a 100-meter (325-foot) interconnection cable limitation. That can be overcome by using a fiber-optic interconnection between the Model 5412 and the Ethernet switch or switches in the one or more associated local-area-networks (LANs).

Ethernet Connections

The Model 5412 provides three Gigabit Ethernet (GigE) ports for flexibility and compatibility with many networking implementations. Two ports are provided for interconnection with one or two local area networks (LAN) associated with Dante audio-over-Ethernet networking schemes. They are labeled PRI for primary and SEC for secondary. Using the Dante Controller application these ports can be configured for Switched or Redundant Dante operation. The third Ethernet port, labeled MGMT, is dedicated to accessing the Model 5412's management resources. An internal web server function supports the Model 5412's management port's webpages. These webpages are used for configuration, monitoring, and maintenance of Model 5412 operation.

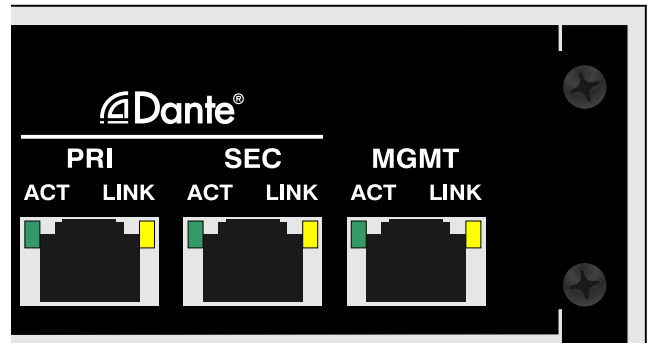

Figure 4. Detail of Model 5412 back panel showing the Ethernet port's RJ45 jacks

By providing three Ethernet ports the Model 5412 allows support for facilities that utilize independent networks for Dante audio transport and equipment management. In this way, “production” networks that support transport of audio signals by way of a single LAN (for Switched Dante) or two LANs (for Redundant Dante) can be separate from an engineering network that is used by technical personnel for configuring and maintaining a facility or “plant.”

Connections to the three Ethernet interfaces are made by way of standard RJ45 jacks that are located on the back of the Model 5412's enclosure. The Ethernet interfaces support auto MDI/MDI-X so that crossover cables are not required. Refer to Appendix A for examples of how the Model 5412's three Ethernet interfaces might be utilized.

Dante Port Connections

At least one 1000BASE-T Gigabit Ethernet (GigE) connection is required for Model 5412 Dante operation. It should be connected to the primary RJ45 jack. A second 1000BASE-T GigE connection can be made to the secondary RJ45 jack if Redundant Dante is desired. While technically 100BASE-TX (100 Mb/s) Ethernet can also be used for these Dante connections, it is not optimal. Additionally, it's important to note that 10BASE-T (10 Mb/s) Ethernet connections are not sufficient.

When configured in Dante Controller for the Switched network mode, the Model 5412's secondary Dante Ethernet connection can also be used as a “loop through” port such as would be provided by an Ethernet switch. However, using the secondary Dante port in Switched mode for applications other than troubleshooting or “looping” to access the Model

5412's management port is not recommended. It will function reliably but "daisy chaining" Ethernet signals can limit flexibility and present a failure point; it's optimal if each Dante Ethernet interface connects directly to a separate port on an Ethernet switch.

Management Port Connection

An Ethernet signal is required to be interconnected with the management jack so that Model 5412 configuration and management can be performed. It's recommended that a 1000BASE-T Gigabit Ethernet (GigE) connection be made but a 100BASE-TX (100 Mb/s) or even a 10BASE-T (10 Mb/s) connection is sufficient. (GigE will provide the best performance and it's assumed that all contemporary applications will support it.) The Model 5412's management port can share a network that is being used by the unit's Dante network connections. Refer to Appendix A for examples of how this can be easily implemented.

Analog Audio Connections

Connecting analog signals to and from the Model 5412 are made by way of 25-pin female D-subminiature (DB-25F) connectors. One D-sub connector is associated with the Model 5412-01's eight analog input channels. Two D-sub connectors are associated with the Model 5412-02's sixteen analog input channels. As might be expected, one D-sub connector is associated with the Model 5412-01's eight analog output channels. And two D-sub connectors are associated with the Model 5412-02's sixteen analog output channels. Refer to Figures 2 and 3 for a view of the D-sub connectors that are located on the back panel.

Analog Inputs

The Model 5412-01 uses one female 25-pin D-subminiature (DB-25F) connector to interface with its eight line-level analog inputs. The connector, located on the unit's back panel, is labeled Analog Inputs 1-8. The Model 5412-02 provides two female 25-pin D-sub connectors to interface with its sixteen line-level analog inputs. The connectors, located on the unit's back panel, are labeled Analog Inputs 1-8 and Analog Inputs 9-16. Refer to Appendix B for details on the exact pinout of these D-sub connectors.

The wiring scheme used by the D-subminiature connectors comply with AES59-2012, as made popular by TASCAM. A wiring assembly prepared for use with the analog input channels would be identical to a standard TASCAM-type input assembly with the exception of using "locking" screws with 4-40 UNC threads.

Each analog input circuit is electronically balanced and optimized for connection to a balanced or unbalanced source with a nominal signal level of +4 dBu. A configuration selection in one of the Model 5412's management webpages allows adjustment of the input gain of each individual channel in 0.1-dB steps over a -20.0 to +20.0 dB range. This will allow the inputs to be made compatible with audio signals that have a wide range of nominal levels. When connecting a consumer-level ("-10 dBV") audio source adding 12.0 dB of gain to each input might be effective.

Balanced analog sources should be wired so that signal high is connected to +, signal low to -, and shield to the shield connection. With an unbalanced source, connect signal high to the + connection, and shield to both the - and the shield connections. If connecting to an unbalanced analog source in this manner results in hum or noise, try connecting signal high to + and shield to -; leave the shield connection unterminated.

Analog Outputs

The Model 5412-01 uses one female 25-pin D-subminiature (DB-25F) connector to interface with its eight line-level analog outputs. The connector, located on the unit's back panel, is labeled Analog Outputs 1-8. The Model 5412-02 provides two female 25-pin D-sub connectors to interface with its sixteen line-level analog outputs. The connectors, located on the unit's back panel, are labeled Analog Outputs 1-8 and Analog Outputs 9-16. Refer to Appendix B for details on the exact pinouts of these D-sub connectors.

The wiring scheme used by the D-subminiature connectors comply with AES59-2012, as made popular by TASCAM. Wiring assemblies prepared for use with the Model 5412's analog output channels should be identical to that of TASCAM-type output assemblies. Note that unlike TASCAM-type assemblies, the Model 5412's D-sub connectors use "locking" screws with 4-40 UNC threads.

The analog outputs are electronically balanced and will perform optimally when driving loads of 2 k (2000) ohms or greater. In most applications, 3-pin male XLR connectors will be used to interface with balanced inputs on the associated devices. In this case, a Model 5412 analog output channel's + terminal would go to pin 2 of the XLR, the – terminal to XLR pin 3, and the shield terminal to XLR pin 1. Balanced connection of the analog output channels is the preferred connection method but unbalanced operation does not pose a problem. To connect to an unbalanced input, connect the + terminal as signal high, and only the Model 5412's shield terminal as the signal low/shield. Leave the – terminal unconnected. For correct unbalanced operation it is important not to connect the – terminal and shield together.

A level trim configuration selection in one of the Model 5412's management webpages allows adjustment of the signal level of each analog output channel in 0.1-dB steps over a –20.0 to +20.0 dB range. This will help to ensure that the analog output channels will be compatible with audio signals and equipment that have a wide range of nominal levels. In some cases, the analog output level might benefit from being reduced, such as by 10.0 dB, rather than having gain added.

Connecting Power

The Model 5412 requires a source of AC mains or nominal 12 volts DC for operation. Either source can be connected with the same result. Both can also be simultaneously connected if a redundant (backup) power scheme is desired.

Connecting AC Mains Power

The Model 5412 can operate directly from AC mains power of 100 to 240 volts, 50/60 Hz, 20 watts maximum. As a "universal mains input" device there are no switches to set or jumpers to install. A 3-pin IEC 320 C14 inlet connector on the back panel mates with a detachable mains cord set.

All units are supplied from the factory with an AC mains cord that has a North-American (NEMA 5-15L) standard plug on one end and an IEC 320 C13 connector on the other end. Units intended for use in other destinations require that an appropriate mains

cord be obtained. The wire colors in the mains cord should conform to the internationally recognized color code and be terminated accordingly:

<u>Connection</u>	<u>Wire Color</u>
Neutral (N)	Light Blue
Line (L)	Brown
Earth/Ground (E)	Green/Yellow

Because the Model 5412 does not contain a power on/off switch it will begin operation as soon as AC mains power is connected.

Safety Warning: The Model 5412 does not contain an AC mains disconnect switch. As such, the AC mains cord plug serves as the disconnection device. Safety considerations require that the plug and associated inlet be easily accessible to allow rapid disconnection of AC mains power should it prove necessary.

Connecting DC Power

The Model 5412 can also operate from a source of 10 to 18 volts DC. The current required from a 12 volts DC source is 1.5 ampere maximum. A 4-pin male XLR connector, located on the unit's back panel, is used to connect the source of DC. Prepare a mating connector (female) so that pin 1 is DC– and pin 4 is DC+. Pins 2 and 3 are not used and should remain unconnected. This connector type and pinout have become a broadcast DC power standard and should be familiar to many technical personnel. Because the Model 5412 contains no power on/off switch it will begin operation as soon as a DC power source is connected.

As previously mentioned, both an AC mains source and a DC source can be connected at the same time. If this is the implementation, the AC mains source will always power the Model 5412 with the DC source serving as a "hot standby." Only if the AC source fails will the unit draw power from the DC source. This will occur automatically with no interruption of Model 5412 operation. In this "standby" mode (when an AC mains source is connected), the Model 5412 will draw less than 120 microamperes (uA) from a connected 12 volts DC source.

Dante Configuration

For audio to correctly pass to and from the Model 5412 requires, at a minimum, that several Dante-related parameters be configured. These configuration settings are stored in non-volatile memory within the Model 5412's Dante network interface circuitry. Configuration will typically be done with the Dante Controller software application, available for download free of charge at audinate.com. Versions of Dante Controller are available to support several operating systems.

The Model 5412's Dante interface is compatible with the Dante Domain Manager (DDM) software application. Refer to DDM documentation, also available from Audinate, for details on which Model 5412 and related parameters may have to be configured.

Audio Routing

The Model 5412-01 has eight Dante transmitter (output) channels which are associated with the unit's eight analog input channels. The Model 5412-01 also has eight Dante receiver (input) channels which are associated with the unit's eight analog output channels. The Model 5412-02 has sixteen Dante transmitter (output) channels which are associated with the unit's sixteen analog input channels. It has sixteen Dante receiver (input) channels associated with the unit's sixteen analog output channels.

The Model 5412's Dante transmitter (output) channels can be assigned to the desired Dante receiver (input) channels on associated equipment. This will route the channels associated with the Dante transmitter (output) channels to the device or devices that will be "listening" to them. Within Dante Controller a "subscription" is the term used for routing a transmitter flow (a group of up to four output channels) to a receiver flow (a group of up to four input channels).

Also using Dante Controller, the desired Dante transmitter (output) sources can be routed to the Model 5412's Dante receiver (input) channels. These channels will be converted to analog outputs by the Model 5412's circuitry.

The Model 5412 uses a Brooklyn module to implement its Dante functionality. The number of flows associated with this module is 64; 32 transmitter (output) and 32 receiver (input), and typically no flow

limitation will occur. Flows, each of which can support up to four audio channels, can operate either as unicast, multicast, or a combination of the two. Note that when the AES67 mode has been enabled, the Model 5412's Dante transmitter (output) channels will only function in multicast; unicast is not supported.

Unit and Channel Names

The Model 5412 has a default Dante device name of **ST-M5412-** along with a unique suffix. The suffix identifies the specific Model 5412 that is being configured. The suffix's actual alpha and/or numeric characters relate to the MAC address of the unit's Brooklyn module.

The Model 5412-01's eight Dante transmitter (output) channels have default names of **Ch1** through **Ch8**. The Model 5412-01's eight Dante receiver (input) channels have default names of **Ch1** through **Ch8**. The Model 5412-02's sixteen Dante transmitter (output) channels have default names of **Ch1** through **Ch16**. The Model 5412-02's sixteen Dante receiver (input) channels have default names of **Ch1** through **Ch16**.

Using Dante Controller, the default device and channel names can be revised as appropriate for a specific application. Refer to Appendix C for a summary of the default channel numbers, names, and descriptions.

Device Configuration

The Model 5412 supports audio sample rates of 44.1, 48, 88.2, and 96 kHz with no pull-up/down options available. The digital audio data is in the form of pulse-code modulation (PCM) samples. Encoding choices within Dante Controller are *PCM 16*, *PCM 24*, and *PCM 32*, but in most cases, the selection of *PCM 24* would be appropriate. Clocking and device latency parameters can be adjusted if required but the default values in Dante Controller are typically correct.

Network Configuration – Dante

The Model 5412 allows connection of three Ethernet signals using standard RJ45 jacks which are located on the back panel. Two jacks are for use by Dante and the third for connecting to a network designated for management or maintenance purposes. The Dante ports are labeled PRI and SEC indicating that they are the primary and secondary connections. How these two ports function can be selected in the

Dante Redundancy section of Dante Controller's Network Configuration tab. The choices are *Switched* or *Redundant*.

If *Switched* is selected, the Model 5412 can establish one connection with an Ethernet network. It doesn't matter which RJ45 jack is utilized, although for clarity this would typically be the primary jack. The secondary RJ45 jack can be used to interconnect with another piece of networked equipment.

If the Model 5412's Dante network is configured for Switched ensure that only one of the two Dante RJ45 jacks on the back panel is connected to the LAN associated with the Dante network. If both of the Model 5412's Dante RJ45 jacks are routed to ports on the same LAN this will typically "crash" the network! (Although some of the latest/most-advanced Ethernet switches will automatically detect and prevent such a "network bridging" issue from occurring.)

If *Redundant* is selected, Dante's Redundant networking capability will be enabled. In this case, separate network connections should be made to the primary and secondary RJ45 jacks.

Network Configuration – IP Addresses

When the Model 5412 has been configured for the *Switched* network mode, a single Dante IP address will be associated with the network connection that is made to either the primary or the secondary Dante RJ45 jack. If the network configuration has been selected for *Redundant*, separate IP addresses and related network parameters will be assigned to the primary and secondary Dante Ethernet ports.

Typically, the Model 5412's Dante IP address or addresses and related network parameters will be determined automatically using DHCP or, if that's not available, the link-local network protocol. If desired, Dante Controller allows IP addresses and related network parameters to be manually set to a fixed (static) configuration. While this is a more-involved process than simply letting DHCP or link-local "do their thing," if fixed addressing is necessary, this capability is available.

Note that if the Model 5412's network configuration has been set for Redundant, the primary and secondary Dante IP addresses and related parameters can

be independently configured. This allows both interfaces to be configured automatically, both interfaces to be configured manually, or one interface configured automatically and the other configured manually.

AES67 Configuration – AES67 Mode

Dante Controller allows a Model 5412 to be configured for AES67 operation. This requires the AES67 mode to be set for *Enabled*. As previously noted, if AES67 mode is *Enabled*, the Dante transmitter (output) channels will use multicast. The sample rate will be fixed at 48 kHz.

Model 5412 Clocking Source

While technically the Model 5412 can serve as a Leader Clock for a Dante network (as can all Dante-enabled devices), in most cases, the unit will be configured to receive its timing reference ("sync") from another Dante device. As such, the Dante Controller check box for the Preferred Leader that is associated with the Model 5412 would typically not be enabled.

Model 5412 Configuration

Many of the Model 5412's operating parameters can be configured using the webpages that are provided by way of the Model 5412's management Ethernet port. A standard web browser is all that is required to utilize the menu webpages. Of course, the device hosting the web browser must be part of the same network that includes the Model 5412's management Ethernet port. The management port's network configuration can be revised using one of the webpages or by way of the front-panel menus.

Management IP Address

With the Model 5412 powered and operational, and a network connection made to the management port, a connection to the web server will typically be established. At this point it should be simple to identify the active management IP address. Two minutes after the last press of a front-panel button a screen saver function will activate. This will cause a continuous sequence of four (Model 5412-01) or six (Model 5412-02) pages to show on the front panel. The page

that appears after the Studio Technologies' logo will show the current management address. Alternately, pressing the front-panel's **Enter** button will result in the current IP address page shown.

How the management Ethernet port obtains its IP address will depend on the Management Address's configuration setting. The Model 5412's management webpages can be used to review or makes changes to the IP address and related parameters. Alternately, the front-panel display and associated pushbutton switches can be utilized.

The default method is automatic such that from the factory the Model 5412's management port will first try to obtain an IP address using DHCP. If that is not successful an IP address will be assigned using the link-local protocol. (A link-local-obtained IP address will be in the format of 169.254.x.x.) It's also possible that the Model 5412 may have been configured to use a manual (fixed or static) IP address.

Accessing the Management Webpages

To access the Model 5412's home page, type the Model 5412's management IP address into the browser's search bar. (It's possible that some browsers may require the text **http://** followed by the IP address.)

Home and Login Menus

Once the Home page shows, access to the configuration menus is possible. Click on the link labeled Log In, on the page's right side, and it will lead to the Login menu webpage. The entry of a valid user name and password is now required. This is not a sophisticated security implementation! It is intended to keep "honest" people from making unauthorized changes to the configuration of the Model 5412.

The screenshot shows the home page of the Model 5412-01 Audio Interface. At the top left is a logo consisting of four green diagonal lines. To the right of the logo, the text "Model 5412-01 Audio Interface" is displayed in green, with the serial number "ST-M5418-1d7576" to its right. Below this is a horizontal green line. Underneath the line, there are two tabs: "Home" (which is selected and highlighted) and "Log In". Below the tabs, the text "Welcome to the Model 5412 Audio Interface" is centered. At the bottom of the page, there is a link to "Studio Technologies, Inc." in green text.

The screenshot shows the login page of the Model 5412-01 Audio Interface. At the top left is the same logo as the home page. To the right, the text "Model 5412-01 Audio Interface" and the serial number "ST-M5418-1d7576" are displayed. Below this is a horizontal green line. Underneath the line, there are two tabs: "Home" and "Login" (which is selected and highlighted). Below the tabs, there are two input fields: "User Name" with the value "guest" and "Password" with the value "guest". Below these fields is a "Log In" button. At the bottom of the page, there is a link to "Studio Technologies, Inc." in green text.

User Name: Enter the Model 5412's user name into this field. It is case sensitive. The default user name is **guest**. If the default user name and password are active, the default user name will show in this field.

Password: Enter the Model 5412's password into this field. It is case sensitive. The default password is **guest**. If the default user name and password are active, the default password will show in this field.

Log In Button: Click on the Log In button to submit the entered user name and password. If the correct entries have been made, access to the configuration menu webpage will show. If an incorrect user name and/or password is entered, a login failed message will be shown.

Configuration Menu Choices

Once a correct user name and password have been submitted the Home menu webpage will again show. In addition, five tabs with other menu choices will also show. The Home menu page now allows the status of three important Model 5412 parameters to be observed. The five menus allow a number of Model 5412 display-only fields to be observed. In addition, these menus can allow many configuration choices to be revised.

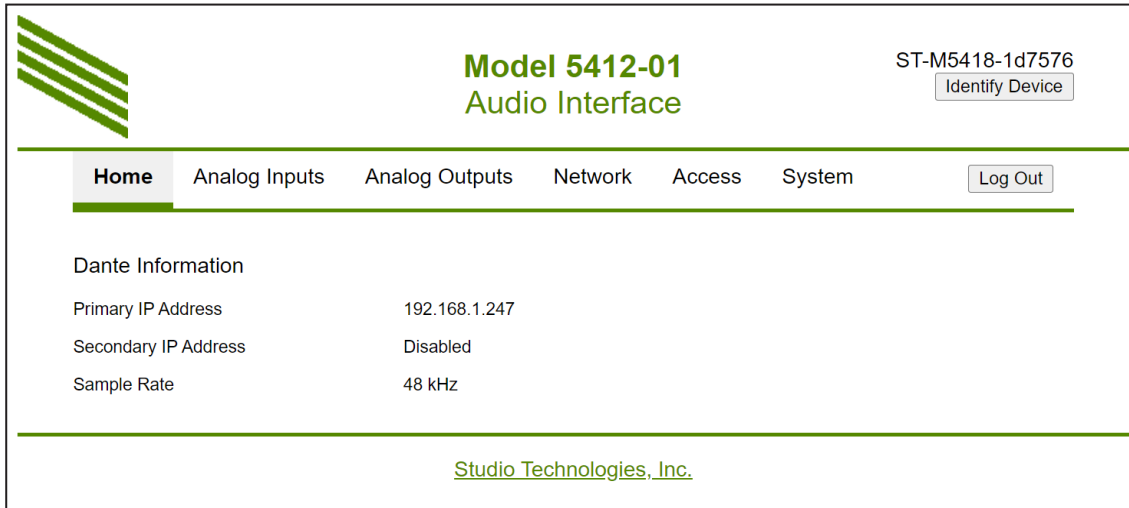

Dante Information

Primary IP Address: This is a display-only field that will show the IP address associated with the Dante primary connection. This address will be shown in the form of four octets separated by periods. If the network configuration in Dante Controller has been selected for *Switched*, the Dante primary connection can be made to either the PRI or the SEC RJ45 jack. If the network configuration in Dante Controller has been selected for *Redundant*, the primary Dante connection will be made to the PRI RJ45 jack. This field will show **No Ethernet Link** if no connection has been made to an applicable Dante Ethernet port.

Secondary IP Address: This is a display-only field that will show the IP address associated with the Dante secondary connection. It will show **Disabled** if the Dante Controller network configuration has been selected for *Switched*. It will show an IP address if Dante Controller's network configuration has been selected for *Redundant* operation and a connection has been made to the SEC RJ45 jack. It will show **No Ethernet Link** if the network configuration has been selected for *Redundant* and no Ethernet connection is present on the SEC RJ45 jack.

Sample Rate: This display-only field will show the Model 5412's Dante transmitter (output) sample rate as configured using Dante Controller. Choices are 44.1 kHz, 48 kHz, 88.2 kHz, and 96 kHz.

Analog Inputs Menu

The Model 5412-01 provides eight analog inputs while the Model 5412-02 provides sixteen. They function similarly but have some specific differences. As such, independent text sections will be provided to describe their operation.

The screenshot shows the web interface for the Model 5412-01 Audio Interface. At the top, there is a logo on the left, the title "Model 5412-01 Audio Interface" in the center, and the device ID "ST-M5418-1d7576" with an "Identify Device" button on the right. Below this is a navigation bar with tabs for "Home", "Analog Inputs" (which is selected), "Analog Outputs", "Network", "Access", and "System", along with a "Log Out" button. The main content area is titled "Level Adjustments" and contains a table with two columns: "Channel" and "Gain (±dB)". The table lists channels 01 through 08, each with a corresponding gain value of 0.0 in a text input field. Below the table is a "Submit" button. Underneath the table, there are two dropdown menus: "Dante Transmitters Source" set to "Analog Inputs" and "Dante Transmitter 8 Source" set to "Analog Input 8". A second "Submit" button is located below these dropdowns. At the bottom of the interface, the text "Studio Technologies, Inc." is displayed.

Channel	Gain (±dB)
01	0.0
02	0.0
03	0.0
04	0.0
05	0.0
06	0.0
07	0.0
08	0.0

Level Adjustments – Model 5412-01

The circuitry associated with the Model 5412-01's eight analog input channels can have its gain individually adjusted (trimmed). The channels are labeled 01 through 08 and the gain range is -20.0 to $+20.0$ in 0.1-dB steps. These gain trim functions can be used to allow the relative level of the analog input sources to be matched. They can also be used to compensate for signals that don't match the Model 5412's analog inputs' nominal level of +4 dBu.

Submit: A submit button is located below the field for channel 8. To save changes made to any of the gain fields requires that the submit button be pressed.

Dante Transmitter Source – Model 5412-01

Choices are: *Analog Inputs*, *Dante Receivers*, *1 kHz Tone*

There are eight Dante transmitter (output) channels associated with the Model 5412-01. The signal sources for these transmitters, as a group, can be selected from among three choices. Refer to Appendix D for a source selection overview. Selecting *Analog Inputs* is the usual setting. This will cause the Model 5412-01 to always use analog inputs 1-7 as the sources for Dante transmitter channels 1-7. These are connected one-to-one, with analog input 1 routed to Dante

transmitter 1, analog input 2 routed to Dante transmitter 2, and so forth through channel 7.

Various combinations of the analog inputs, from a single channel up to all eight, can be selected as the source or sources for Dante transmitter channel 8. The ability to sum (mix or combine) analog input sources was specifically included to support applications that in the past may have utilized the RTS MDA-100 product. Using the Model 5412-01 the 4-wire analog intercom resources provided by multiple camera control unit (CCU) hardware units can be easily integrated into Dante applications.

Selecting *Dante Receivers* causes the Model 5412-01's eight Dante receiver (input) channels to be used as the signal sources for the eight Dante transmitter (output) channels. The channels are mapped one-to-one, with Dante receiver channel 1 routed to Dante transmitter channel 1, Dante receiver channel 2 routed to Dante transmitter channel 2, etc. This setting can be considered as a Dante loopback function that would typically only be used for test purposes.

Selecting *1 kHz Tone* makes a 1 kHz sine-wave tone with a level of -20 dBFS present on all eight of the Model 5412-01's Dante transmitter (output) channels. This is an excellent method to provide a known signal source on all of the Dante transmitter (output) channels and is expected to be useful for test situations. The Model 5412-01 does not allow the frequency and/or output level of the tones to be adjusted.

Dante Transmitter Channel 8 Source

Choices are: *Analog Input 8*

Sum of Analog Inputs 1-8

Sum of Analog Inputs 3-8

Sum of Analog Inputs 5-8

Sum of Analog Inputs 7-8

When Analog Inputs is selected as the overall Dante transmitter source, the specific source or sources for Dante transmitter channel 8 can be selected from among five choices. Selecting *Analog Input 8* will cause Dante transmitter channel 8 to function as an analog input/Dante output conversion channel, the same function that is always performed by channels 1-7. The other four choices allow various combinations of the analog inputs to be summed (mixed or combined), then sent to Dante transmitter (output)

channel 8. The analog input sources are summed, in the digital domain, at unity, meaning that no gain or loss (attenuation) is automatically applied to the related analog inputs. However, adjustment of the level of each individual input channel is possible. The channel level adjustment function for each analog input channel will apply before ("pre") the summing function, thus allowing ± 20 dB of control in 0.1-dB steps.

For CCU-associated intercom applications the 4-wire analog output signals from two or more CCU units can be summed (mixed or combined) and output by way of Dante transmitter channel 8. It's possible that the signal level of Dante transmitter channel 8 could be considered to be too high ("hot") when multiple channels are being summed. An easy remedy is available: Simply attenuate (apply a negative gain) to all the related analog inputs. In this way, the nominal level of Dante transmitter channel 8 will be reduced. For example, when combining the outputs of four CCUs it might be appropriate to apply -3.0 or -6.0 dB to the gain fields. Combining eight CCU 4-wire analog outputs might benefit having -6.0 or -9.0 dB of attenuation applied to all of the related analog inputs. Technically, the greater the number of phase-coherent signals that are being summed the greater the resulting output level. As such, this will dictate the amount of attenuation that should be applied to the analog input signals.

Submit: A submit button is located below the two fields. To save changes made to the fields requires that the submit button be pressed.

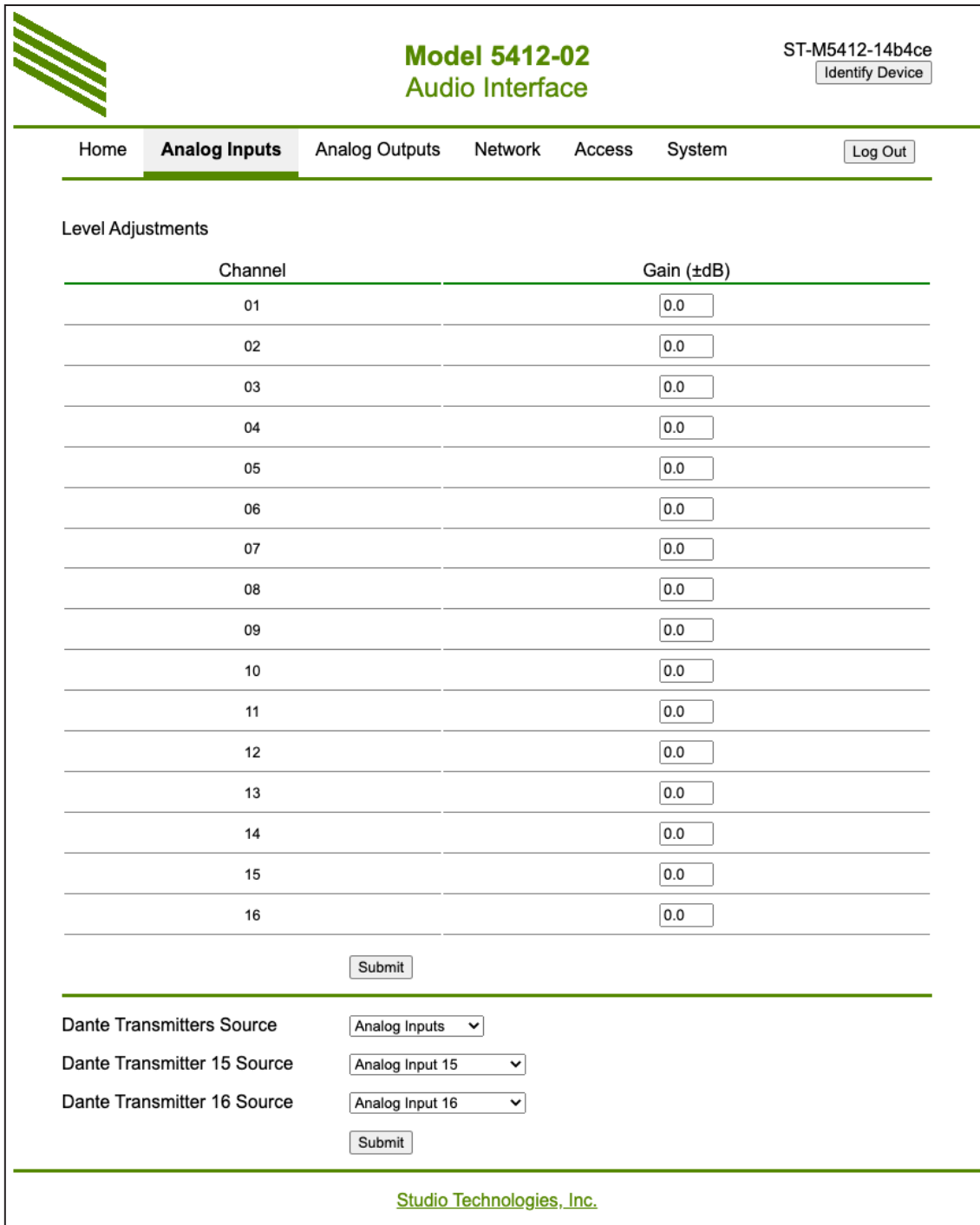

Model 5412-02
Audio Interface

ST-M5412-14b4ce

Home
Analog Inputs
Analog Outputs
Network
Access
System

Level Adjustments

Channel	Gain (±dB)
01	<input type="text" value="0.0"/>
02	<input type="text" value="0.0"/>
03	<input type="text" value="0.0"/>
04	<input type="text" value="0.0"/>
05	<input type="text" value="0.0"/>
06	<input type="text" value="0.0"/>
07	<input type="text" value="0.0"/>
08	<input type="text" value="0.0"/>
09	<input type="text" value="0.0"/>
10	<input type="text" value="0.0"/>
11	<input type="text" value="0.0"/>
12	<input type="text" value="0.0"/>
13	<input type="text" value="0.0"/>
14	<input type="text" value="0.0"/>
15	<input type="text" value="0.0"/>
16	<input type="text" value="0.0"/>

Dante Transmitters Source

Dante Transmitter 15 Source

Dante Transmitter 16 Source

[Studio Technologies, Inc.](#)

Level Adjustments – Model 5412-02

The circuitry associated with Model 5412-02’s sixteen analog input channels can have its gain individually adjusted (trimmed). The channels are labeled 01 through 16 and the gain range is –20.0 to +20.0 in 0.1-dB steps. These gain trim functions can be used to allow the relative level of the analog input sources

to be matched. They can also be used to compensate for signals that don’t match the Model 5412’s analog inputs’ nominal level of +4 dBu.

Submit: A submit button is located below the field for channel 16. To save changes made to any of the gain fields requires that the submit button be pressed.

Dante Transmitters Source – Model 5412-02

Choices are: *Analog Inputs*, *Dante Receivers*,
1 kHz Tone.

There are sixteen Dante transmitter (output) channels associated with the Model 5412-02. The signal sources for these transmitters, as a group, can be selected from among three choices. Refer to Appendix D for a source selection overview. Selecting *Analog Inputs* is the usual setting. This will cause the Model 5412-02 to always use analog inputs 1-14 as the sources for Dante transmitter channels 1-14. These are connected one-to-one, with analog input channel 1 routed to Dante transmitter channel 1, analog input channel 2 routed to Dante transmitter channel 2, and so forth through channel 14.

Various combinations of the analog inputs, from a single channel up to all sixteen, can be selected as the source or sources for Dante transmitter channels 15 and 16. The ability to sum (mux or combine) analog input sources was specifically included to support applications that in the past may have utilized the RTS MDA-100 product. Using the Model 5412-02 the 4-wire analog intercom resources provided by multiple camera control unit (CCU) hardware units can be easily integrated into Dante applications.

Selecting *Dante Receivers* causes the Model 5412-02's sixteen Dante receiver (input) channels to be used as the signal sources for the sixteen Dante transmitter (output) channels. The channels are mapped one-to-one, with Dante receiver channel 1 routed to Dante transmitter channel 1, Dante receiver channel 2 routed to Dante transmitter channel 2, etc. This setting can be considered as a Dante loopback function that would typically only be used for test purposes.

Selecting *1 kHz Tone* makes a 1 kHz sine-wave tone with a level of –20 dBFS present on all sixteen of the Dante transmitter (output) channels. This is an excellent method to provide a known signal source on all of the Dante transmitter (output) channels and is expected to be useful for test situations. The Model 5412-02 does not allow the frequency and/or output level of the tones to be adjusted.

Dante Transmitter Channel 15 Source

Choices are: *Analog Input 15*
Sum of Analog Inputs 1-2
Sum of Analog Inputs 1-4
Sum of Analog Inputs 1-6
Sum of Analog Inputs 1-8
Sum of Analog Inputs 1-10
Sum of Analog Inputs 1-12
Sum of Analog Inputs 1-14
Sum of Analog Inputs 1-16

When *Analog Inputs* is selected as the overall Dante transmitter source, the specific source or sources for Dante transmitter channel 15 can be selected from among nine choices. Selecting *Analog Input 15* will cause Dante transmitter channel 15 to function as an analog input/Dante output conversion channel, the same function that is always performed by channels 1-14. The other eight choices allow various combinations of the analog inputs to be summed (mixed or combined), then sent to Dante transmitter channel 15. The analog input sources are summed, in the digital domain, at unity, meaning that no gain or loss (attenuation) is automatically applied to the related analog inputs. However, adjustment of the level of each individual input channel is possible. The channel level adjustment function for each analog input channel will apply before (“pre”) the summing function, thus allowing ± 20 dB of control in 0.1-dB steps.

For CCU-associated intercom applications the 4-wire analog output signals from two or more CCU units can be combined and output by way of Dante transmitter channel 15. It's possible that the signal level of Dante transmitter channel 15 could be considered to be too high (“hot”) when multiple channels are summed. An easy remedy is available: simply attenuate (apply a negative gain) to all the related analog inputs. In this way, the nominal level of Dante transmitter channel 15 will be reduced. For example, when combining the outputs of four CCUs it might be appropriate to apply –3.0 or –6.0 dB to the gain fields. Combining eight CCU 4-wire analog outputs might benefit from applying –6.0 or –9.0 dB of attenuation to all the related analog inputs. Technically, the greater the number of phase-coherent signals that are being summed the greater the resulting output level. As such, this will dictate amount of attenuation that should be applied to the input signals.

Dante Transmitter Channel 16 Source

Choices are: *Analog Input 16*

Sum of Analog Inputs 1-16

Sum of Analog Inputs 3-16

Sum of Analog Inputs 5-16

Sum of Analog Inputs 7-16

Sum of Analog Inputs 9-16

Sum of Analog Inputs 11-16

Sum of Analog Inputs 13-15,

Sum of Analog Inputs 15-16

The flexibility provided for selecting the analog input signal source or sources for Dante transmitter channel 16 is similar to that provided for Dante transmitter channel 15. The exception is that the exact input summing combinations that can be selected is slightly different. As such, please refer to the previous paragraphs for details on selecting a configuration.

Submit: A submit button is located below the three fields. To save changes made to the fields requires that the submit button be pressed.

Analog Outputs Menu

The Model 5412-01 provides eight analog output channels while the Model 5412-02 provides sixteen. They function similarly, the only difference being the number of output channels.

The screenshot shows the web interface for the Model 5412-01 Audio Interface. At the top, there is a logo on the left, the title "Model 5412-01 Audio Interface" in the center, and the device ID "ST-M5418-1d7576" with an "Identify Device" button on the right. Below this is a navigation bar with tabs for "Home", "Analog Inputs", "Analog Outputs" (which is selected), "Network", "Access", and "System", along with a "Log Out" button. The main content area is titled "Level Adjustments" and contains a table with two columns: "Channel" and "Gain (±dB)". The table lists channels 01 through 08, each with a gain value of 0.0 in a text input field. Below the table is a "Submit" button. Underneath the table is the "Analog Outputs Source" section, which has a dropdown menu currently set to "Dante Receivers" and a "Submit" button. At the bottom of the interface, the text "Studio Technologies, Inc." is displayed.

Channel	Gain (±dB)
01	0.0
02	0.0
03	0.0
04	0.0
05	0.0
06	0.0
07	0.0
08	0.0

Level Adjustments – Model 5412-01

The circuitry associated with the Model 5412-01's eight analog output channels can have its gain individually adjusted (trimmed). The channels are labeled 01 through 08 and the gain range is -20.0 to $+20.0$ in 0.1 -dB steps. These gain trim functions can be used to allow the relative level of each analog output channel to be matched. They can also be used to adjust the analog output levels such that their nominal level is something different than the unit's default nominal level of $+4$ dBu. (The default nominal level is achieved with a gain level setting of 0 dB.) The level adjustment settings will apply to each analog output channel, no matter what signal source has been selected. This means that the level trim settings will apply to their

associated analog outputs whether the analog inputs, the Dante receiver (input) channels, or the 1 kHz tone generator is serving as the audio sources.

Submit: A submit button is located below the field for channel 8. To save changes made to any of the gain fields requires that the submit button be pressed.

Analog Outputs Source – Model 5412-01

Choices are: *Analog Inputs*, *Dante Receivers*, *1 kHz Tone*

There are eight analog output channels associated with the Model 5412-01. Each analog output is electronically balanced (differential) and intended to drive balanced or unbalanced loads of 2 k (2000) ohms

or greater. The nominal level of the analog outputs is +4 dBu. The signal source for these analog outputs, as a group, can be selected from among three choices. Refer to Appendix D for a source selection overview.

Selecting *Analog Inputs* will cause the Model 5412-01 to use analog inputs 1-8 as the sources for analog outputs 1-8. These are used one-to-one, with analog input 1 routed to analog output 1, analog input 2 routed to analog output 2, and so forth. It can be considered as an analog loopback function. This choice is provided primarily as a means to support testing of the analog input, analog output, channel wiring, and related analog signal source and signal destination devices. In addition, this choice would allow a Model 5412-01 to be tested in an application where the unit has been fully installed but the associated Dante network has yet to be “commissioned.” Using the analog inputs choice would allow the analog “side” of a Model 5412-01 deployment to be tested.

Selecting *Dante Receivers* is the usual setting, configuring the Model 5412-01’s eight Dante receiver (input) channels to be used as the signal sources for the eight analog output channels. The channels are mapped one-to-one, with Dante receiver channel 1 routed to analog output channel 1, Dante receiver channel 2 routed to analog output channel 2, etc.

Selecting *1 kHz Tone* makes a 1 kHz sine-wave tone with a level of +4 dBu nominal to be present on the Model 5412-01’s eight analog output channels. This is an excellent method to provide a known signal source on all of the analog output channels and is expected to be useful for test situations. The Model 5412-01 does not allow the frequency and/or output level of the tones to be adjusted.

Note that for applications where the Model 5412-01 is going to be used in place of an RTS MDA-100 product, one analog output channel would typically be connected to one 4-wire intercom input on a CCU (camera control unit). As such, in applications where eight CCUs are utilized, all eight of a Model 5412-01’s analog outputs would be connected to the analog inputs on the eight CCUs. To get the same “talk” signal present on all eight analog outputs (a distribution amplifier function) would be very simple. The audio source that’s going to be sent to all eight CCUs would

need to be present on one Dante transmitter (output) channel. Then, using the Dante Controller application, this single Dante transmitter (output) source would be connected (routed or Dante subscribed) to all eight of the Model 5412-01’s Dante receiver (input) channels. In this way, the same signal would end up on the eight analog output channels. Should the signal levels need to be adjusted the level adjustment functions, one for each analog output channel, can be utilized.

Submit: A submit button is located below the field for selecting the analog output source. To save a change requires that the submit button be pressed.

Model 5412-02
Audio Interface

ST-M5412-14b4ce
Identify Device

Home Analog Inputs **Analog Outputs** Network Access System Log Out

Level Adjustments

Channel	Gain (±dB)
01	0.0
02	0.0
03	0.0
04	0.0
05	0.0
06	0.0
07	0.0
08	0.0
09	0.0
10	0.0
11	0.0
12	0.0
13	0.0
14	0.0
15	0.0
16	0.0

Submit

Analog Outputs Source Dante Receivers

Submit

Studio Technologies, Inc.

Level Adjustments – Model 5412-02

The circuitry associated with the Model 5412-02's sixteen analog output channels can have their gain individually adjusted (trimmed). The channels are labeled 01 through 16 and the gain range is –20.0 to +20.0 in 0.1-dB steps. They function identically to that provided for the eight channels associated with the Model 5412-01.

Analog Outputs Source – Model 5412-02

There are sixteen analog output channels associated with the Model 5412-02. As with the Model 5412-01, there are three choices for the analog output source. The information provided in the previous section will also apply to the Model 5412-02. They function in the same way so a separate explanation is not required.

Network Menu

Model 5412-01
Audio Interface

ST-M5418-1d7576
Identify Device

Home Analog Inputs Analog Outputs **Network** Access System Log Out

Management Interface

MAC Address 00-04-22-F6-06-40

Current IP Address 192.168.1.148

IP Address Configuration Automatic ▾

Manual IP Address

Subnet Mask 255.255.255.0

Gateway IP Address 192.168.1.1

Submit

[Studio Technologies, Inc.](#)

Management Interface

MAC Address: This is a display-only field that shows the MAC (media access control) address associated with the Model 5412's management Ethernet port. This is a unique hardware identification number that is assigned to this port on each specific Model 5412. No two Ethernet-connected devices should ever share a MAC address.

Current IP Address: This is a display-only field that shows the IP address actively associated with the Model 5412's management web server. The web server is accessed with an Ethernet network connection made to the RJ45 jack labeled MGMT on the Model 5412's back panel. This address can be assigned automatically via DHCP or IPv4 link-local. It can also be manually assigned with a fixed or static IP address. The Current IP Address is not associated with the Model 5412's primary or secondary Dante Ethernet ports.

IP Address Configuration: This is a configurable field with two choices: *Automatic* and *Manual*. To minimize the chance of losing access to the internal management web server restoring the Model 5412's factory defaults will not change the currently selected choice.

This configuration impacts how the Model 5412 obtains the IP address that is used for accessing the Model 5412's management web server and associated menu webpages. This setting has no impact on how the Model 5412 obtains the primary and secondary IP addresses that are associated with its Dante Ethernet connections.

Selecting the *Automatic* setting will cause the Model 5412 to use DHCP or IPv4 link-local to establish the IP address for the Model 5412's management port. With this setting, upon establishing a link to the Model 5412's management RJ45 jack the DHCP protocol will request an IP address and related parameters. If obtaining an IP address by way of the DHCP protocol is not successful, the IPv4 link-local protocol will be used. If an IP address has the format of 169.254.x.x, it was assigned using IPv4 link-local.

Even if the management IP address was established using link-local the DHCP protocol will stay active. The Model 5412's firmware will continue to check for the presence of a DHCP server. If one becomes available, an IP address will be requested and, when obtained, it will automatically be used, replacing the IP address that was previously established by link-local.

The Manual setting allows the desired IP address and related parameters to be manually entered. This can be useful when a fixed addressing scheme has been established. In this way, a static IP address can be entered along with the other important network parameters.

When selected for *Automatic*, the fields for manual IP address, subnet mask, gateway IP address, and DNS IP address will be “grayed out” (will have a gray background) to indicate that their values cannot be manually changed. In this condition, they are display-only. Changing between Automatic and Manual and vice-versa will not impact the values stored in the manual IP address, subnet mask, gateway IP address, and DNS IP address fields. Note the front-panel display and associated pushbutton switches can also be used to revise the Model 5412’s management IP address configuration.

Manual IP Address: This field is grayed out and will not show any text when the IP address configuration mode is selected for *Automatic*. When the IP address configuration is selected for *Manual*, this field will show the IP address that is stored in the Model 5412. This is the IP address that is currently being used, or will be used at the time of the next Ethernet management connection reboot. It is the IP address that allows access to the Model 5412’s management web server and associated menu webpages. It has nothing to do with the IP addresses associated with the primary and secondary Dante Ethernet connections.

The manual IP address can be modified as desired to meet the requirements of the application. After entering an IP address using the standard dot-decimal notation format (four octets separated by dots), the submit button must be pressed for the changes to be stored. Restoring the Model 5412 default values will not change the stored IP address. A system reboot is required for the revised manual IP address to be utilized. Note that the front-panel display and associated pushbutton switches can also be used to revise the Model 5412’s manual IP address.

Subnet Mask: This field is grayed out when the IP address configuration mode is selected for *Automatic*. This field will be display-only in this instance and will show an IPv4 subnet mask in dot-decimal notation (four octets separated by dots) if the current IP

address and related network parameters were obtained by way of DHCP. This is the subnet mask that is being used by the internal management web server. If the IP address configuration mode is selected for *Automatic* and the current IP address was obtained by way of link-local, a subnet mask address of 255.255.0.0 will be shown in this field.

When the IP address configuration is selected for *Manual*, the subnet mask field will not be grayed out. In this situation, the stored subnet mask will be shown and can be modified as desired to meet the requirements of the application. The shown value is the subnet mask that is currently in use, or will be used at the time of the next Ethernet management connection reboot. After entering an IP address using the standard dot-decimal notation format (four octets separated by dots), the submit button must be pressed for a change to be stored. A system reboot is required for the revised subnet mask value to be utilized. Restoring the Model 5412 default values will not change the stored subnet mask value. Note that the front-panel display and associated pushbutton switches can also be used to revise the Model 5412’s management subnet mask.

Gateway IP Address: This field is grayed out when the IP address configuration mode is selected for *Automatic*. This field will be display-only in this instance and will show an IPv4 gateway IP address in dot-decimal notation (four octets separated by dots) if the current IP address and related network parameters were obtained by way of DHCP. This is the gateway IP address that is being used by the Model 5412’s management web server.

If the IP address configuration mode is selected for *Automatic* and the current IP address was obtained by way of link-local, no gateway IP address will be shown in this field. This is because no gateway IP address is associated with link-local.

When the IP address configuration is selected for *Manual*, the gateway IP address field will not be grayed out. In this situation, the stored gateway IP address will be shown and can be modified as desired to meet the requirements of the application.

The shown value is the gateway IP address that is currently in use, or will be used at the time of the next Ethernet management connection reboot. After

entering a gateway IP address using the standard dot-decimal notation format (four octets separated by dots), the submit button must be pressed for a change to be stored. A system reboot is required for the revised gateway IP address to be utilized. Restoring the Model 5412's default values will not change the stored gateway IP address value.

Submit: A submit button is located near the bottom of the Network menu webpage. For any changes made to fields to the Network configuration to be saved the submit button must be pressed.

Access Menu

Model 5412-01
Audio Interface

ST-M5418-1d7576
Identify Device

Home Analog Inputs Analog Outputs Network **Access** System Log Out

Front Panel Control View/Edit ▾
Submit

Management Login Credentials

User Name guest
New Password
Confirm New Password
Default User Name is 'guest'; default Password is 'guest'.
Submit

[Studio Technologies, Inc.](#)

Front Panel Control

Choices are: *View/Edit*, *View Only*

A graphics display and five associated pushbutton switches are located on the Model 5412's front panel. This field allows the action of the pushbutton switches to be selected from among two choices. When *View/Edit* is selected, the buttons can be used to select what is shown on the display as well as allowing several configuration choices to be changed. When *View Only* is selected, the pushbutton switches will only allow selection of what information is able to be shown; they will not allow configuration changes to be made. Refer to Appendix E for a detailed list of the front-panel menus.

Submit: A submit button is located below the Front Panel Control selection field. This button must be pressed for a change made to the Front Panel Control configuration to be saved.

Management Login Credentials

As a security method a user name and password must be entered before the configuration webpages can be accessed. These values can be changed as desired.

The Model 5412's access security method is in no way rigorous. The user name and password are sent to and received from the Model 5412 as plain text. They are also stored within the Model 5412 as plain text. There is no security method or encryption associated with these fields. Anyone "snooping" on the LAN that is transporting Model 5412 management data will see all values in plain text! The user name and password values are intended simply to provide a means of keeping "friendly" or "honest" users from easily changing the configuration of a Model 5412. If unauthorized access is of concern, it's recommended that an Ethernet connection to the Model 5412's management RJ45 jack not be present except when access by authorized personnel is desired.

The default user name is **guest** and the default password is **guest**. These are case sensitive. If neither of these default values is changed, they will show in the user name and password entry fields on the Login menu webpage. If the default user name and/or default password is changed, neither the user name nor the password will show upon accessing the Login menu webpage.

User Name: In this field, a revised user name can be entered. The user name has a minimum of five characters, a maximum of 15 characters, and is case sensitive. All 95 of the printable ASCII characters can be used. These include upper and lower alphabetic characters, numbers, and standard punctuation marks.

New Password: In this field, a revised password can be entered. The password is a minimum of five characters, a maximum of 15 characters, and is case sensitive. All 95 of the printable ASCII characters can be used. These include upper and lower alphabetic characters, numbers, and standard punctuation marks.

Confirm New Password: For a new password to be considered valid it must also be entered in this field.

Submit: A submit button is located below the field for Confirm New Password. To save changes made to the user name and/or new password fields requires that the submit button be pressed.

System Menu

Model 5412-01
Audio Interface

ST-M5418-1d7576
Identify Device

Home Analog Inputs Analog Outputs Network Access **System** Log Out

Serial Number 01600

Version Information

	Version	Date
Main MCU	2.00	19 Dec 2022
Main FPGA	1.00	16 Dec 2018
Dante Product	4.4.0	23 Aug 2022
Dante Firmware	4.2.7.4	---

Restore Default Configuration

Operational Settings

Management Interface and Access Settings

Submit

System Reboot

Reboot

[Studio Technologies, Inc.](#)

Serial Number: This is a display-only field that shows the Model 5412’s hardware serial number. A 5-digit number, it is assigned at the factory and cannot be changed.

Version Information

Seven display-only fields will show information about the firmware (embedded software) that is currently loaded and operating in this specific Model 5412.

Main MCU: Two display-only fields show the version number and release date of the Model 5412’s Main MCU firmware. This is the firmware that runs in the Model 5412’s microcontroller (MCU) integrated circuit. This firmware can be updated using a USB flash drive. Details are provided in the Technical Notes section.

Main FPGA: Two display-only fields show the version number and release date of the firmware used by the Model 5412’s programmable logic (FPGA) device. This is the firmware that runs in the Model 5412’s high-speed logic device. This firmware can be updated using a USB flash drive. Details are provided in the Technical Notes section.

Dante Product: Two display-only fields show the product version number and date that’s contained in the Model 5412’s Dante interface (Brooklyn module). These numbers and dates are assigned by Studio Technologies, Inc. as an identifier when releasing a version of the Dante firmware. The firmware for the Model 5412’s Dante interface can be updated by way of an Ethernet connection using the Dante Updater

software application that's provided as part of the Dante Controller software application.

Dante Firmware: This is a display-only field that shows the version number of the firmware associated with the Dante interface (Brooklyn module) that the Model 5412 utilizes for Dante interconnectivity. (There is no associated date.) This version number is assigned by Audinate and can't be changed by Studio Technologies, Inc. As noted previously, the firmware for the Model 5412's Dante interface can be updated by way of an Ethernet connection using the Dante Updater software application.

Restore Default Configuration: There are two check boxes associated with the restore default configuration function. Either or both can be selected prior to pressing the Submit button. Enabling the Operational Settings check box allows all the Model 5412's configuration settings to be restored to their factory default values with the exception of the management interface and user access settings. The six configuration values associated with these two functions will not change. Enabling the Management Interface and Access Setting check box allows the Model 5412's factory default configuration settings for the IP Address Configuration method, Manual IP Address, Subnet Mask, Gateway IP Address, User Name, and Password to be returned to their factory default values. Refer to Appendix F for a list of the these values.

System Reboot: A check box and a reboot button are provided in the System Reboot section of this menu page. This function is provided to allow a user to force the Model 5412 to restart operation. Any changes made to the network configuration and/or user name and password settings will be in effect. Once the Reboot check box has been enabled, pressing the Reboot button will cause the Model 5412 to halt current operation and restart ("boot") the unit.

Automatic Log Out

Once a web browser has successfully logged into the Model 5412's menu system a 15 minute inactivity timer will become active. If no configuration setting has been changed, a webpage refreshed, or a webpage newly accessed for 15 minutes, the

user will automatically be logged out. Returning to the menu pages will require the log in procedure to be successfully completed.

Menu Text and Links

The following paragraphs provide details on some of the links, buttons, and text that are presented on the Model 5412's webpages.

Company Name Link: On the bottom of each webpage is a link with the title Studio Technologies, Inc. Clicking on this link will cause the browser to open the home webpage of the Studio Technologies' website.

Device Name: In the upper-right corner of each Model 5412 webpage is the Model 5412's Dante device name. This name is unique to each device in a Dante deployment and is used as part of Dante subscriptions (channel routing). The name can be changed from within the Dante Controller application.

Identify Device Button: In the upper-right corner of most Model 5412 webpages is a button called Identify Device. Clicking on it will cause the Dante identify action to commence on the specific Model 5412 unit. A unique lighting sequence will take place using the seven LEDs that are located on the Model 5412's front panel. In addition, the LEDs associated with the three RJ45 jacks on the back panel will flash for several seconds. The identify command will help users ensure that the web server on the desired Model 5412 is being accessed.

Log Out Button: Also in the upper-right of each Configuration menu webpage is a button called Log Out. It will cause the Model 5412's web server to end the active session and log out the user. To again access the menu webpages will require that a user provide a valid user name and password.

Operation

Now that the Model 5412 is installed and configured, it's ready for use. Normally no operator intervention should be required. However, there are a number of nuances in the unit's operation. This may make it useful for technical personnel to spend some time reviewing this section.

Upon application of AC mains or DC power, the Model 5412 will go through several power-up sequences. The LED associated with the USB receptacle on the unit's back panel will briefly light green to indicate that it is functioning. The LEDs associated with the Model 5412's three Ethernet jacks will flash several times as part of the associated Ethernet interface integrated circuit's power-up action. The seven LEDs on the unit's front panel will first light green, then light red in a confirmation sequence. While the LEDs are going through their power-up sequence, the front-panel display will first show the unit's model number (Model 5412) and Dante device name. The screen will then show the unit's Main MCU firmware version number. After a few seconds the Studio Technologies' logo will show followed by the screen save function becoming active. Details about the screen saver function are covered in later sections.

After the Model 5412 has completed its power-up sequences full operation will begin. The Model 5412's front panel contains seven bi-color LEDs which reflect the real-time status of unit's major functions. The two power LEDs indicate the presence of incoming AC mains and 12 volts DC power. They are labeled AC and DC. When a source of AC mains power is connected the AC LED will light green. The DC LED will light green whenever a connected DC source

exceeds approximately 10 volts. The DC LED will light red when the DC input is between approximately 9 and 10 volts, indicating a low-voltage condition. If the DC input is less than approximately 9 volts the DC LED will not light and the Model 5412 will no longer operate from the DC source.

Two LEDs are associated with the Model 5412's Dante interface. The system LED, labeled SYS, and the synchronization LED, labeled SYNC, will both light red as the unit's Dante interface starts to function and awaits connection to the associated LAN or LANs. The system LED will light red to indicate that the interface is not ready to pass data to other devices. It will blink red if there is an issue communicating with the internal Dante Brooklyn module. (This should never occur unless there is a Model 5412 hardware problem.) It will light green when it is operating normally and is ready to pass data.

The synchronization LED will light red to indicate that the Model 5412's Dante interface has not established timing synchronization. It will light solid green when it has synchronized with a Dante network and an external clock source (timing reference) is being received. The synchronization LED will slowly flash green if this specific Model 5412 is part of a Dante network and is serving as the Leader Clock. (In this case, it's likely that other Dante devices are following this Model 5412 which is acting as their timing reference.) It's possible that up to 30 or 40 seconds may be required for the synchronization LED to reach its final state.

Two LEDs are associated with the Model 5412's primary and secondary Dante Ethernet connections. They are labeled PRI and SEC. How they respond will depend on the unit's network configuration as

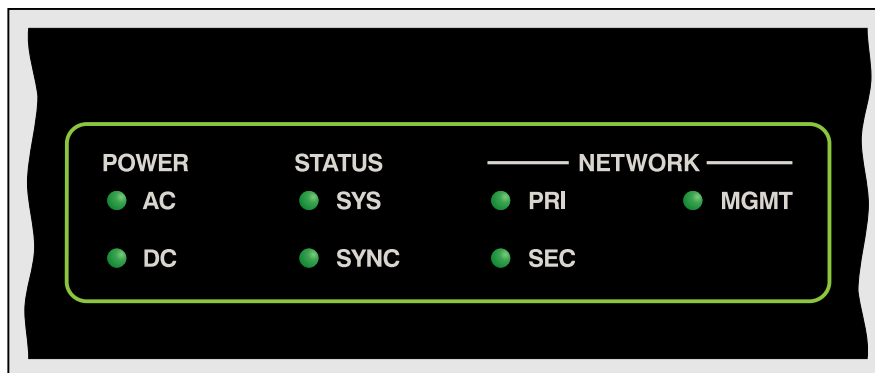

Figure 5. Detail of Model 5412 front panel showing LEDs

made in the Dante Controller application. When the Dante interface has been configured for *Switched* operation, the primary LED will light red when no Ethernet connection is present. It will light green when a Gigabit Ethernet (GigE) connection is present. It will light orange when a 100 Mb/s Ethernet connection is present. The secondary LED will not light when an Ethernet connection is not present. It will light green when a GigE or a 100 Mb/s Ethernet connection is present.

When the Model 5412's Dante interface has been configured for *Redundant* operation, the primary and secondary LEDs will light red when Ethernet connections are not present on their respective RJ45 jacks. Each will light green when a Gigabit Ethernet (GigE) connection has been made and orange when a 100 Mb/s Ethernet connection has been made.

One LED is associated with the Model 5412's management Ethernet connection. The LED, labeled MGMT, will not light if an Ethernet connection has not been made. It will light green if a GigE or a 100 Mb/s Ethernet connection has been made.

RJ45 LED Indicators

On the Model 5412's back panel there are three RJ45 jacks that are provided for interfacing with the unit's three Gigabit Ethernet (GigE) ports. Two of the jacks are designated for Dante audio use and the third for management functions. The three RJ45 jacks are labeled Dante PRI, Dante SEC, and MGMT. Associated with each jack are two LEDs. One LED is labeled LINK and lights orange when a GigE connection has been established with that specific jack. The LINK LED will not light if a 100 Mb/s Ethernet connection has been made. It will also not light if an Ethernet connection has not been made. The second LED, labeled ACT, will flash green to indicate data activity, responding to Ethernet traffic traveling to and from that specific jack.

Front-Panel Display Page Descriptions

The following sections provide information about the Model 5412's front-panel menu pages. Additional details can be found in the Model 5412 Configuration section. Refer to Appendix E for the menu structure diagram.

The Access Menu web configuration menu page has a selection called Front Panel Control. When the choice of *View/Edit* is selected, the five front-panel pushbutton switches are, in certain circumstances, able to revise six Model 5412 configuration parameters. An arrow icon will show in the upper-right corner of these pages if a configuration change can be made. If the Front Panel Control configuration is selected for *View Only*, no configuration changes can be made using the pushbutton switches. In this case, a lock icon will show in the upper-right corner of the six menu pages.

Row One

For the Model 5412-01 there are two display-only menu pages associated with the top row which we'll refer to as Row One. For the Model 5412-02 there are four display-only menu pages. These relate to the real-time signal levels of the Dante transmitter (output) channels and the analog output channels.

Dante Transmitter Channels 1-8: This menu page will show, in the form of vertical bar graphs, the levels of Dante transmitter (output) channels 1-8. The levels are shown in dBFS with a reference mark and text shown at -20 dBFS. (This is the Model 5412's default Dante transmitter (output) level.) The letter D will show on the left side of this page to indicate that the menu page represents Dante transmitter (output) channels.

Dante Transmitter Channels 9-16: This menu page will only be present in a Model 5412-02. It will show the levels of Dante transmitter (output) channels 9-16.

Analog Output Channels 1-8: This menu page will show, in the form of vertical bar graphs, the levels of analog output channels 1-8. The levels are shown in dBu with a reference mark and text shown at $+4$ dBu. (This is the Model 5412's default analog output level.) The letter A will show on the left side of this page to indicate that the menu page represents analog output channels.

Analog Output Channels 9-16: This menu page will only be present in a Model 5412-02. It will show the levels of analog output channels 9-16.

Row Two

There are two pages associated with row two. They show the current configuration and, by default, allow changes to the sources selected for the Dante transmitter (output) channels and the analog output channels.

Dante Transmitter Source Select: This menu page will show the current signal sources, as a group, that are used for the Dante transmitter (output) channels. It will also allow selection from among three choices: *Analog Input Channels*, *Dante Receiver Channels*, and *1 kHz Tone*.

An arrow icon will show in the upper-right corner of this menu page to indicate that the setting can be changed. If the active method is not the desired one, press the **Enter** pushbutton switch located on the front panel. Use the up and down arrow buttons to select the desired sources. (For clarity, the configuration choice that is currently active will have an asterisk (*) at the end of its title.) Again press the **Enter** button. The entry will then be stored and the selected sources utilized.

Analog Output Source Select: This menu page will show the current signal sources, as a group, that are used for the analog output channels. It will also allow selection from among three choices: *Analog Input Channels*, *Dante Receiver Channels*, and *1 kHz Tone*.

An arrow icon will show in the upper-right corner of this menu page to indicate that the setting can be changed. If the active method is not the desired one, press the **Enter** pushbutton switch located on the front panel. Use the up and down arrow buttons to select the desired sources. (For clarity, the configuration choice that is currently active will have an asterisk (*) at the end of its name.) Again press the **Enter** button. The entry will then be stored and the selected sources utilized.

Row Three

Row three has a total of five display-only menu pages. The information provided relates to the Dante name and Dante interfaces.

Dante Device Name: The Dante device name is shown on this menu page. This name is unique to each device in a Dante deployment and is used

as part of the Dante subscription (channel routing) process. The name can be changed from within the Dante Controller application. The text shown on this menu page is the same as is shown in the upper-right corner of each Model 5412 management webpage.

Dante Primary IP Address: This menu page shows the IP address associated with the Dante primary interface. This address has nothing to do with the IP addresses utilized by the Dante secondary and management interface ports. The standard dot-decimal notation is used to show the Dante primary IP address.

If the network configuration is selected for *Switched* in the Dante Controller application, the Dante primary IP address will be associated with an Ethernet connection made to either the primary or the secondary RJ45 jack on the Model 5412's back panel. If no Ethernet connection has been made to either RJ45 jack, the text **No Ethernet Link** will show.

If the network configuration is selected for *Redundant*, the Dante primary IP address will be associated with the RJ45 jack labeled PRI on the Model 5412's back panel. If no Ethernet connection has been made to this RJ45 jack, the text **No Ethernet Link** will show.

Dante Secondary IP Address: This menu page shows the IP address associated with the Dante secondary interface. Again, this address has nothing to do with the IP addresses utilized by the Dante primary and management interface ports. The standard dot-decimal notation is used to show the Dante secondary IP address.

If the network configuration is selected for *Switched* in the Dante Controller application, the text **Disabled** will be shown.

If the network configuration is selected for *Redundant*, the Dante secondary IP address be shown in this menu page. This address will be associated with the RJ45 jack labeled SEC on the Model 5412's back panel. If no Ethernet connection has been made to this RJ45 jack, the text **No Ethernet Link** will show.

Dante Product Version: This menu page shows the product version number associated with the Model 5412's Dante interface. The Model 5412's Dante interface is implemented using a Brooklyn module from Audinate. This version number is assigned by Studio

Technologies as an identifier when a file is released that combines specific Model 5412 configuration information along with the Audinate-developed Dante operating firmware. The firmware for the Model 5412's Dante interface can be updated by way of an Ethernet connection using the Dante Updater software application that's provided as part of the Dante Controller software application.

Dante Firmware Version: This menu page shows the version number of the firmware that's stored in and being utilized by the Brooklyn module that the Model 5412 utilizes for Dante interconnectivity. The version number shown is assigned by Audinate and can't be changed by Studio Technologies. It is incorporated into the Dante product firmware file (with the extension .dnt) that is released by Studio Technologies specifically for the Model 5412. As noted previously, this firmware, part of the Dante product firmware, can be updated by way of an Ethernet connection using the Dante Updater software application.

Row Four

Row four has four front-panel menu pages that involve the management IP address and related parameters. One menu page is display-only and the other three, by default, allow changes to be made.

Current Management IP Address: This menu page will show the IP address associated with the Model 5412's internal management web server. This is the IP address that's associated with the connection made to the Model 5412's management RJ45 jack which is located on the back panel. This address can be assigned automatically using the DHCP protocol or, if a DHCP server is not available, using the IPv4 link-local protocol. (If the IP address shown is in the format of 169.254.x.x it was assigned using IPv4 link-local.) The management IP address can also be assigned with a manual (fixed or static) IP address. If no Ethernet connection has been made with this RJ45 jack, the text **No Ethernet Link** will be shown.

Management IP Configuration: This menu page allows the display and revision of the method that the Model 5412 uses to obtain a management IP address and related parameters. The choices are *Automatic* and *Manual*. The selected configuration impacts how the Model 5412 obtains the IP address

that is used for accessing the management web server and associated menu webpages. This setting has no impact on how the Model 5412 obtains IP addresses for the Dante primary and Dante secondary Ethernet interfaces.

An arrow icon will show in the upper-right corner of this menu page to indicate that the setting can be changed. If the active method is not the desired one, press the **Enter** pushbutton switch located on the front panel. Use the left and right arrow buttons to select the desired method. (For clarity, the configuration choice that is currently active will have an asterisk (*) at the end of its name.) Again press the **Enter** button. The entry will be stored. To cause the Model 5412 to use a new setting requires that the unit be rebooted (restarted). This can be performed using another front-panel menu page, a selection in one of the management webpages, or by power cycling the unit.

Selecting the *Automatic* setting causes the Model 5412 to use DHCP or, if DHCP is not available, the IPv4 link-local protocol to establish the IP address for the management port. Even if the IP address was established using link-local the DHCP protocol will remain active. In this case, approximately every 30 seconds the Model 5412's firmware will check for the presence of a DHCP server. If one becomes available, an IP address will be requested and, when obtained, it will automatically replace the IP address that was previously established by link-local.

The *Manual* setting allows the desired IP address and related parameters to be manually entered. This can be useful when a fixed or static addressing scheme has been established. In this way, a designated IP address can be entered along with the other necessary network parameters.

Note that to minimize the chance of losing access to the management web server, restoring the Model 5412's default configuration values will not change the currently selected IP address configuration choice.

Manual Management IP Address: This menu page shows the stored IP address associated with the management web server. This address has nothing to do with the IP address utilized by the Dante primary and Dante secondary Ethernet interfaces. It will

be utilized only when the manual mode has been selected for the management IP address configuration. When the IP address configuration has been selected for *Automatic*, this field cannot be changed and a lock icon will show in the upper-right corner of the display.

Whenever the IP address configuration is selected for *Manual*, the manual IP address can be modified as desired. This will be indicated by an arrow icon that will show in the upper-right corner of the display. To start the process of changing the manual management IP address press the **Enter** pushbutton switch on the front panel. An icon with a wrench and screwdriver will show to indicate that an edit is in process. Use the left and right arrow pushbutton switches to select which specific digit of the IP address number is to be modified. Press the up and down arrow pushbuttons to select the desired number. The standard dot-decimal notation is used to show and revise the IP address. Once all the desired changes have been made press the **Enter** button to store them.

To cause the Model 5412 to use a new setting requires that the unit be rebooted (restarted). This can be performed using another front-panel menu page, using a function on a management webpage, or by power cycling the unit. Restoring the Model 5412 to its default values will not change the stored manual IP address.

Manual Management Subnet Mask Value: This menu page shows the stored subnet mask value associated with accessing the management web server. As expected, this value has nothing to do with the subnet mask values utilized by the Dante primary and Dante secondary ports. It will be utilized only when the manual mode has been selected for the management IP address configuration. When the IP address configuration has been selected for *Automatic*, this field cannot be changed and a lock icon will show in the upper-right corner of the display.

Whenever the IP address configuration is selected for *Manual*, the manual management subnet mask value can be modified as desired. This will be indicated by an arrow icon that will show in the upper-right corner of the display. To start the process of changing the subnet mask value press the **Enter** pushbutton switch on the front panel. An icon with a wrench and screwdriver will show to indicate that an edit is in process.

Use the up and down arrow pushbutton switches to select the desired subnet mask value. Once the desired value has been selected, press the **Enter** button to store it.

To cause the Model 5412 to use a new manual management subnet mask value requires that the unit be rebooted (restarted). This can be performed using another front-panel menu page, using a function on a management webpage, or by power cycling the unit. Restoring the Model 5412 to its default values will not change the stored subnet mask value.

Row Five

Row five contains four menu pages. Three of the menu pages are display-only and provide information about the specific Model 5412, including its serial number and version numbers of the firmware (embedded software) that are in use. A fourth menu page that allows, by default, the system to be rebooted (restarted).

Product Name & Serial Number: This menu page shows the name of the product (**Model 5412**) and the hardware serial number. This name and serial number (along with the three MAC addresses associated with the Ethernet interfaces) are assigned at the factory and cannot be changed.

Main MCU Firmware Version: This menu page shows the version number of the Model 5412's Main MCU firmware. This firmware can be updated using a USB flash drive. Update details are provided in the Technical Notes section.

Main FPGA Firmware Version: This menu page shows the version number of the Model 5412's Main FPGA (field-programmable gate array) firmware. This firmware can be updated using a USB flash drive. Update details are provided in the Technical Notes section.

Reboot System: This menu page allows the Model 5412 to be rebooted (restarted). This can be useful to force the Model 5412 to utilize revised management and Dante interface configuration changes. It will also cause the Dante interface to reboot. An arrow icon shows in the upper-right corner of this menu. To start the process of rebooting the Model 5412 press the **Enter** pushbutton on the unit's front panel. This will lead to a confirmation page being shown. Use the

left and right arrow pushbutton switches to select the desired action. The choices are to cancel or to confirm. Press the **Enter** pushbutton switch to select the highlighted action. The Model 5412 will then immediately commence the selected action.

After performing a system reboot (restart), 20 to 60 seconds may be required for the Model 5412's operation to fully restore. During this time period the management Ethernet port will briefly disconnect and then reconnect.

Screen Saver: A "screen saver" mode will automatically activate two minutes after the last press of one of the five front-panel pushbutton switches and if one of the menus from rows 2-5 is actively being shown. The screen saver will not invoke if one of the level metering functions, provided in row 1 of the front-panel menus, is active. When active, the screen saver mode will cause a continuous sequence of four (for the Model 5412-01) or six (for the Model 5412-02) menu pages to show. The sequence of display-only pages consists of the Studio Technologies' logo showing for three seconds and then each of the subsequent menu pages being present for three seconds. The display sequence is continuous, each time moving on to show the next menu page.

When the screen saver mode is active, pressing the **Enter** pushbutton switch on the front panel will cause it to stop and immediately show item one of row one, the Dante transmitter (output) level meter for channels 1-8. To view the current management IP address from this menu page simply press the down pushbutton switch three times. To cause the screen saver mode to immediately start, simultaneously press the left and right arrow pushbutton switches on the front panel.

The four menu pages in the Model 5412-01's screen save mode are:

1. Studio Technologies' company logo graphic.
2. Current management IP address.
3. Level meters for Dante transmitter (output) channels 1-8.
4. Level meters for analog output channels 1-8.

The six menu pages in the Model 5412-02's screen save sequence are:

1. Studio Technologies' company logo graphic.
2. Current management IP address.
3. Level meters for Dante transmitter (output) channels 1-8.
4. Level meters for Dante transmitter (output) channels 9-16.
5. Level meters for analog output channels 1-8.
6. Level meters for analog output channels 9-16.

Details regarding the information provided in the screen saver menu pages were documented in previous sections.

Technical Notes

Dante IP Addresses

If the Model 5412's Dante interface has been configured in the Dante Controller application for Switched operation, by default the Model 5412's Dante primary Ethernet interface will attempt to automatically obtain an IP address and associated settings using DHCP (Dynamic Host Configuration Protocol). If a DHCP server is not detected, an IP address will automatically be assigned using the link-local protocol. This protocol is known in the Microsoft® world as Automatic Private IP Addressing (APIPA). It is also sometimes referred to as auto-IP (PIPPA). Link-local will randomly assign a unique IP address in the IPv4 format of 169.254.x.x. In this way, multiple Dante-enabled devices will connect together and automatically function, whether or not a DHCP server is active on the LAN. Even two Dante-enabled devices that are directly interconnected using an RJ45 patch cord should, by way of link-local, correctly acquire IP addresses and be able to communicate with each other. As previously discussed, using Dante Controller the Model 5412's Dante Ethernet IP address(es) and related network parameters can also be set for manual (fixed or static) operation.

If the Model 5412's Dante interface has been configured in Dante Controller for Redundant operation, by default both the Model 5412's Dante primary and Dante secondary Ethernet interfaces will attempt to automatically obtain IP addresses and associated network settings using DHCP. If DHCP is not available, link-local IP addresses will be assigned.

Link-local will assign an IP address in the format of 169.254.x.x for Dante primary and 172.31.x.x for Dante secondary. If automatic assignment of IP addresses is not desired each interface can be individually configured using Dante Controller to use a manual (fixed or static) IP address and related network parameters.

The specific IP address assigned to each of the Model 5412's Dante interfaces can be identified using several methods. The Dante Controller application will directly show the network parameters of the primary and, if utilized, secondary Ethernet interfaces. Another means is to utilize the Model 5412's network webpage to directly show the IP addresses assigned to the Dante primary and, if utilized, Dante secondary Ethernet ports. The Model 5412's front-panel menu system can also be selected to show the Dante primary IP address.

Optimizing Dante Network Performance

For best Dante audio-over-Ethernet performance a network that supports VoIP QoS (voice-over-Internet-protocol quality of service) capability is recommended. This can typically be implemented on virtually all contemporary managed Ethernet switches. There are even specialized switches that are optimized for entertainment-associated applications. Refer to the Audinate website (audinate.com) for details on how to optimize a network for Dante applications.

Management IP Address

By default, the Model 5412's management Ethernet interface address configuration is set for automatic. In this way, it will attempt to automatically obtain an IP address and associated settings using DHCP. If a DHCP server is not detected an IP address will automatically be assigned using the link-local protocol in the IPv4 range of 169.254.x.x. Using the network configuration webpage provided as part of the Model 5412's management system the management Ethernet IP address and related network parameters can also be set for a manual (fixed or static) configuration.

Firmware Update Procedure

It's possible that updated versions of the two firmware (embedded software) files that are utilized by the Model 5412's microcontroller and FPGA (field-programmable gate array) integrated circuit will be released to add features or correct issues. Refer to the Studio Technologies' website for the latest firmware files. The Model 5412 has the ability to load revised files into non-volatile memory by way of a standard USB flash drive.

The Model 5412 implements a USB host function and provides access by way of a type A receptacle located on the unit's back panel. The Model 5412 updates its firmware using files named **M5412.bin** for the Main MCU firmware and **SFB.bit** for the Main FPGA firmware.

The update process begins by preparing a USB flash drive. The flash drive doesn't have to be empty (blank) but must be in the personal computer-standard FAT32 format. Either or both of the firmware files can be automatically loaded at the same time. On the flash drive's root folder, save the desired new firmware file(s), ensuring that the required name or names are specified. For the Main MCU firmware the file name must be **M5412.bin**. For the Main FPGA firmware the file name must be **SFB.bit**.

Studio Technologies will supply each firmware file inside a .zip archive file. While the firmware file inside of the zip file will adhere to the naming convention required by the Model 5412, the name of the zip file itself will include the file's version number. For example, a file named **M5412v2r03MCU.zip** would indicate that version 2.03 of the Main MCU firmware (**M5412.bin**) is contained within this zip file.

Once the USB flash drive is inserted into the USB receptacle, located on the back panel, the Model 5412 must be powered off and again powered on. At this point the file(s) will automatically load. The precise steps required will be highlighted in the next paragraphs.

To install either or both of the firmware files follow these steps:

1. Remove power from the Model 5412. This will entail either removing the AC mains power connector or removing the external source of 12 volts DC. (Both must be disconnected if dual powering has been implemented.)
2. Locate the USB receptacle on the Model 5412's back panel. It is labeled Firmware Update. Directly adjacent to the USB receptacle is a small hole that provides visual access to a green LED indicator.
3. Insert the prepared USB flash drive into the USB receptacle.
4. Apply power to the Model 5412. Power can be provided by connecting AC mains or a source of 12 volts DC.
5. After a few seconds the Model 5412 will run a "boot loader" program that will automatically load and save the new firmware file(s) that are present on the USB flash drive. The update process can range from approximately 15 seconds to approximately 45 seconds, depending on which of the two files are going to be updated. While files are being loaded the green LED, located adjacent to the USB receptacle, will flash slowly. Once the entire loading process has completed the Model 5412 will restart using the newly saved Main MCU and/or Main FPGA firmware.
6. At this time the Model 5412 is functioning with the newly loaded firmware and the USB flash drive can be removed. To be conservative, remove the power source first, then remove the USB flash drive.
7. It's a good idea to confirm that the desired firmware has been loaded and that the Model 5412's Main MCU and Main FPGA firmware versions are operating as expected. To observe the Model 5412's Main MCU firmware version number, simply view the unit's front-panel display as the unit powers up. The version number of the Main MCU firmware for the Model 5412 will show as part of the unit's start-up sequence. To observe the version numbers of the Model 5412's Main FPGA and Dante firmware requires accessing the Model 5412's System webpage. (This webpage will also show the version number of the Main MCU firmware.)

Note that upon power being applied to the Model 5412 if a connected USB flash drive doesn't have a correct file in its root folder no harm will occur. Upon power up, the green LED, located adjacent to the USB receptacle, will flash on and off rapidly for a few seconds to indicate that a valid file has not been found. After this warning, normal operation using the unit's existing firmware will begin.

Dante Firmware Update

As previously discussed, the Model 5412 implements Dante connectivity using the Brooklyn module from Audinate. The firmware (embedded software) residing in the Brooklyn module can be updated using one of the Model 5412's Dante Ethernet ports. The Dante Controller software application can be used to determine the version of the firmware (embedded software) that resides in the Brooklyn module. The System Information webpage provided by the Model 5412's web server can also be used to identify the firmware version. The Dante Controller software application includes an automated method of updating the Brooklyn module's firmware. It's called Dante Updater and is very easy to use. The Dante Controller application is available, free of charge, on the Audinate website audinate.com.

The latest Model 5412 Dante firmware file, with an extension of .dnt, is available on the Studio Technologies' website as well in Audinate's product library database. The latter allows the Dante Updater software application that is included with Dante Controller to automatically update the Model 5412's Dante interface.

Restoring Factory Default Settings

A command in the System Information webpage provided by the Model 5412's web server allows most of the configuration settings to be restored to their factory default values. This can be useful but must be used with caution. Any customization made to the Model 5412's configuration will be lost. This can be offset in a positive way by returning the Model 5412 to a known configuration, a point that might aid in troubleshooting an issue. Refer to Appendix F for a list of the default values.

Lost User Name and/or Password

As is covered in detail in other sections, gaining access to the Model 5412's configuration menu webpages requires entering the correct user name and password. If the default entries, both of which are **guest**, are stored for use, they will show on the Login menu webpage. Pressing the Log In button on that webpage will access the Home configuration webpage. If either or both the user name and the password have been configured to be something other than **guest** (the default), nothing will show in the fields associated with the login menu webpage.

If knowledge of the stored user name and/or password is "lost," the Model 5412 includes a "back door" to allow access. As a security measure physical access to the unit is required to utilize that access method; there is no means to access the unit via an Ethernet port without knowledge of the user name and password. The exact process of accessing the Model 5412's configuration webpages without knowledge of the user name and/or password is detailed in Appendix G.

Specifications

Versions Available:

Model 5412-01: 8 line-level analog inputs and 8 line-level analog outputs (Order Code: M5412-01)

Model 5412-02: 16 line-level analog inputs and 16 line-level analog outputs (Order Code: M5412-02)

Network Audio Technology:

Type: Dante audio-over-Ethernet

AES67-2018 Support: yes

Dante Domain Manager™ (DDM) Support: yes

Ethernet Interface Configuration: Switched or Redundant

Sample Rates: 44.1, 48, 88.2, and 96 kHz

Bit Depth: up to 24

Number of Dante Transmitter (Output) Channels: 8 (Model 5412-01) or 16 (Model 5412-02)

Number of Dante Receiver (Input) Channels: 8 (Model 5412-01) or 16 (Model 5412-02)

Number of Dante Flows: 32 transmitter, 32 receiver

Network Interfaces:

Qty: 3; Dante Primary, Dante Secondary, and Management

Type: 1000BASE-T Gigabit Ethernet (GigE) per IEEE 802.3ab (100 Mb/s also supported but not recommended for optimal performance; 10 Mb/s not supported)

Ethernet Connection NIC Status LEDs: one link and one activity for each Ethernet interface

Remote Configuration Capability: uses webpages provided by internal web server

Analog Inputs:

Type: electronically balanced, capacitor coupled, intended for connection to balanced (differential) or unbalanced signal sources

Impedance: 20 k ohms

Nominal Level: +4 dBu, reference –20 dBFS, adjustable ± 20 dB in 0.1-dB steps

Maximum Level: +24 dBu, results in digital output level of 0 dBFS

Dynamic Range: 120 dB, A-weighted

Distortion (THD+N): <0.0004% (–108 dB), ref 1 kHz, +23 dBu input/–1 dBFS output

Frequency Response: ± 0.2 dB, 14 Hz to 20 kHz

Analog Outputs:

Type: electronically balanced, capacitor coupled, intended to drive balanced or unbalanced loads of 2 k ohms or greater

Source Impedance: 200 ohms

Nominal Level: +4 dBu, reference –20 dBFS, adjustable ± 20 dB in 0.1-dB steps

Maximum Level: +24 dBu

Dynamic Range: >119 dB, A-weighted

Distortion (THD+N): <0.001% (–101 dB), reference 1 kHz, –1 dBFS input/+23 dBu output

Frequency Response: ± 0.1 dB, 6 Hz to 20 kHz

1 kHz Tone Output:

Analog: 1 kHz sine-wave at +4 dBu, nominal, adjustable ± 20 dB in 0.1-dB steps

Dante (Digital): sine-wave at –20 dBFS, fixed

Front-Panel Display: backlit LCD

Software Updating: USB flash drive supports updating of Main MCU and Main FPGA firmware (embedded software); Dante interface updated via Ethernet interface

Power Sources:

AC Mains: 100 to 240 V, 50/60 Hz; 15 W maximum (M5412-01), 20 W maximum (M5412-02)

DC: 10 to 18 V, 1.0 A maximum (M5412-01), 1.5 A maximum (M5412-02); 120 μ A nominal with 12 volts DC and AC mains present, 170 μ A nominal with 18 volts DC and AC mains present

Connectors:

Analog Inputs and Analog Outputs: 25-pin female D-subminiature (DB-25F), AES59-2012-compliant

Ethernet: 3, RJ45 jack

USB: type A receptacle (used only for updating firmware)

AC Mains Input: 3-blade, IEC 320 C14-compatible (mates with IEC 320 C13)

DC Input: 4-pin male XLR (pin 1 negative, pin 4 positive)

Environmental:

Operating Temperature: 0 to 50 degrees C (32 to 122 degrees F)

Storage Temperature: –40 to 70 degrees C (–40 to 158 degrees F)

Humidity: 5 to 95%, non-condensing

Altitude: not characterized

Dimensions – Overall:

19.0 inches wide (48.3 cm)

1.72 inches high (4.4 cm)

7.8 inches deep (19.8 cm); 8.3 inches (21.1 cm) overall

Mounting: one space (1U) in a standard 19-inch rack

Weight: 3.2 pounds (1.5 kg)

Specifications and information contained in this User Guide subject to change without notice.

Appendix A – Network Configuration Examples

ONE LAN – SWITCHED DANTE MODEL 5412 NETWORK INTERFACE CONFIGURED FOR SWITCHED OPERATION

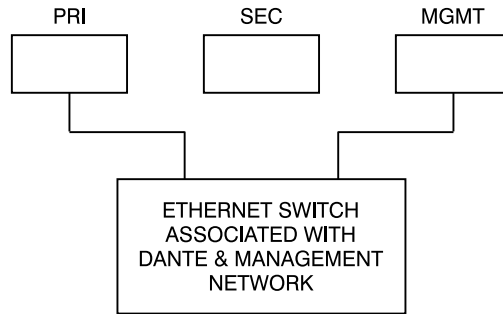

ONE LAN – SWITCHED DANTE MODEL 5412 NETWORK INTERFACE CONFIGURED FOR SWITCHED OPERATION

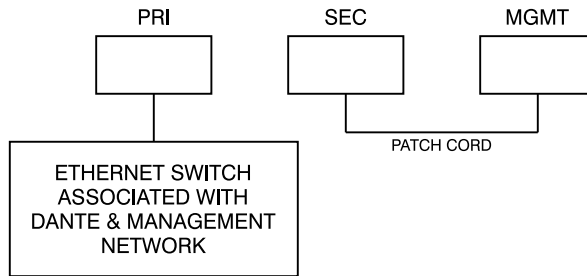

TWO LANs – SWITCHED DANTE MODEL 5412 NETWORK INTERFACE CONFIGURED FOR SWITCHED OPERATION

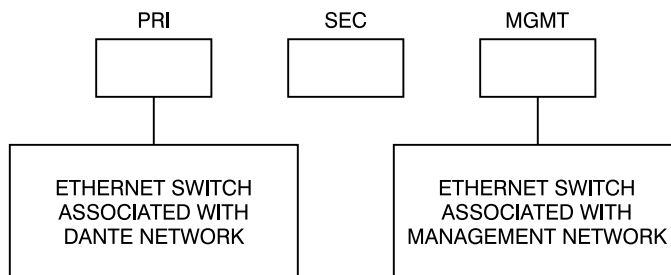

TWO LANs – REDUNDANT DANTE
MODEL 5412 NETWORK INTERFACE
CONFIGURED FOR REDUNDANT OPERATION

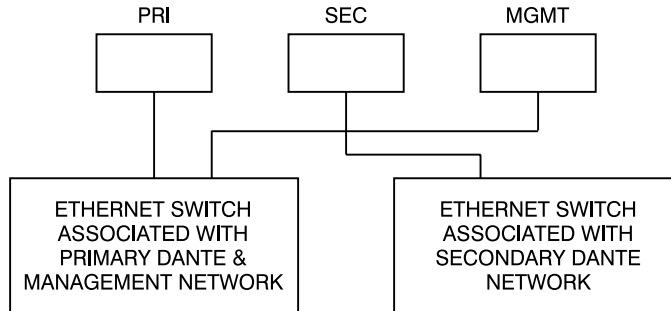

TWO LANs – REDUNDANT DANTE
MODEL 5412 NETWORK INTERFACE
CONFIGURED FOR REDUNDANT OPERATION

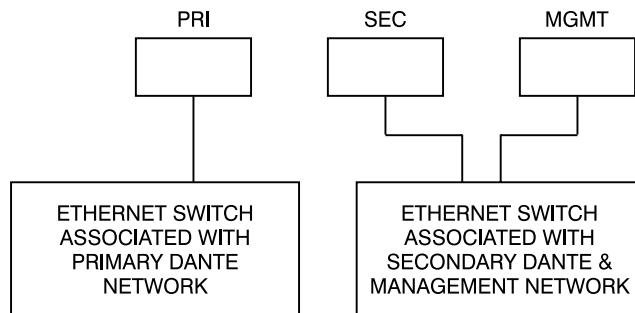

THREE LANs – REDUNDANT DANTE
MODEL 5412 NETWORK INTERFACE
CONFIGURED FOR REDUNDANT OPERATION

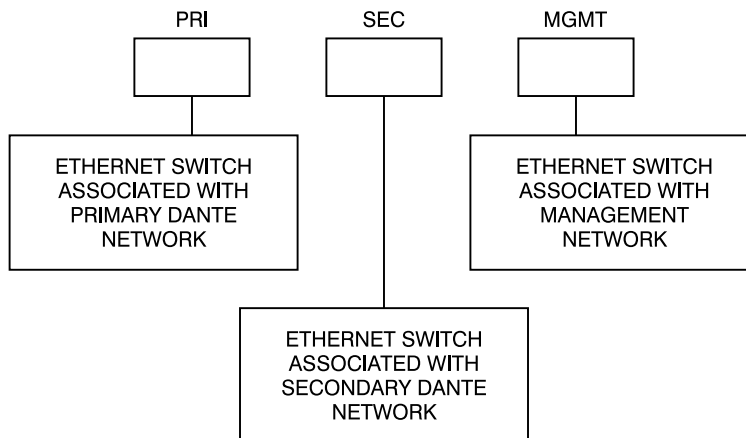

Appendix B – Connection Pin-Out Charts

Notes:

- 1) Connector type is 25-pin female D-subminiature (DB-25F). Installer must provide male (DB-25M). Connectors use 4-40 UNC threaded inserts for locking with mating plugs.
- 2) Wiring schemes follow AES59-2012 convention. Standard TASCAM-type wiring harnesses are typically compatible (locking hardware requires 4-40 UNC screw threads).

Model 5412-01 Analog Inputs and Analog Outputs

Connections for Analog Input Channels 1-8

Channel	High (+)	Low (-)	Shield
1	24	12	25
2	10	23	11
3	21	9	22
4	7	20	8
5	18	6	19
6	4	17	5
7	15	3	16
8	1	14	2

Connections for Analog Output Channels 1-8

Channel	High (+)	Low (-)	Shield
9	24	12	25
10	10	23	11
11	21	9	22
12	7	20	8
13	18	6	19
14	4	17	5
15	15	3	16
16	1	14	2

Model 5412-02 Analog Inputs and Analog Outputs

Connections for Analog Input Channels 1-8

Channel	High (+)	Low (-)	Shield
1	24	12	25
2	10	23	11
3	21	9	22
4	7	20	8
5	18	6	19
6	4	17	5
7	15	3	16
8	1	14	2

Connections for Analog Output Channels 1-8

Channel	High (+)	Low (-)	Shield
9	24	12	25
10	10	23	11
11	21	9	22
12	7	20	8
13	18	6	19
14	4	17	5
15	15	3	16
16	1	14	2

Connections for Analog Input Channels 9-16

Channel	High (+)	Low (-)	Shield
1	24	12	25
2	10	23	11
3	21	9	22
4	7	20	8
5	18	6	19
6	4	17	5
7	15	3	16
8	1	14	2

Connections for Analog Output Channels 9-16

Channel	High (+)	Low (-)	Shield
9	24	12	25
10	10	23	11
11	21	9	22
12	7	20	8
13	18	6	19
14	4	17	5
15	15	3	16
16	1	14	2

Appendix C – Default Dante Channel Names

Model 5412-01

Dante Transmitters (Outputs)

Number	Name	Description
1	Ch1	From Analog Input Channel 1
2	Ch2	From Analog Input Channel 2
3	Ch3	From Analog Input Channel 3
4	Ch4	From Analog Input Channel 4
5	Ch5	From Analog Input Channel 5
6	Ch6	From Analog Input Channel 6
7	Ch7	From Analog Input Channel 7
8	Ch8	From Analog Input Channel 8

Dante Receivers (Inputs)

Number	Name	Description
1	Ch1	To Analog Output Channel 1
2	Ch2	To Analog Output Channel 2
3	Ch3	To Analog Output Channel 3
4	Ch4	To Analog Output Channel 4
5	Ch5	To Analog Output Channel 5
6	Ch6	To Analog Output Channel 6
7	Ch7	To Analog Output Channel 7
8	Ch8	To Analog Output Channel 8

Model 5412-02

Dante Transmitters (Outputs)

Number	Name	Description
1	Ch1	From Analog Input Channel 1
2	Ch2	From Analog Input Channel 2
3	Ch3	From Analog Input Channel 3
4	Ch4	From Analog Input Channel 4
5	Ch5	From Analog Input Channel 5
6	Ch6	From Analog Input Channel 6
7	Ch7	From Analog Input Channel 7
8	Ch8	From Analog Input Channel 8
9	Ch9	From Analog Input Channel 9
10	Ch10	From Analog Input Channel 10
11	Ch11	From Analog Input Channel 11
12	Ch12	From Analog Input Channel 12
13	Ch13	From Analog Input Channel 13
14	Ch14	From Analog Input Channel 14
15	Ch15	From Analog Input Channel 15
16	Ch16	From Analog Input Channel 16

Dante Receivers (Inputs)

Number	Name	Description
1	Ch1	To Analog Output Channel 1
2	Ch2	To Analog Output Channel 2
3	Ch3	To Analog Output Channel 3
4	Ch4	To Analog Output Channel 4
5	Ch5	To Analog Output Channel 5
6	Ch6	To Analog Output Channel 6
7	Ch7	To Analog Output Channel 7
8	Ch8	To Analog Output Channel 8
9	Ch9	To Analog Output Channel 9
10	Ch10	To Analog Output Channel 10
11	Ch11	To Analog Output Channel 11
12	Ch12	To Analog Output Channel 12
13	Ch13	To Analog Output Channel 13
14	Ch14	To Analog Output Channel 14
15	Ch15	To Analog Output Channel 15
16	Ch16	To Analog Output Channel 16

Appendix D – Source Selection Overview

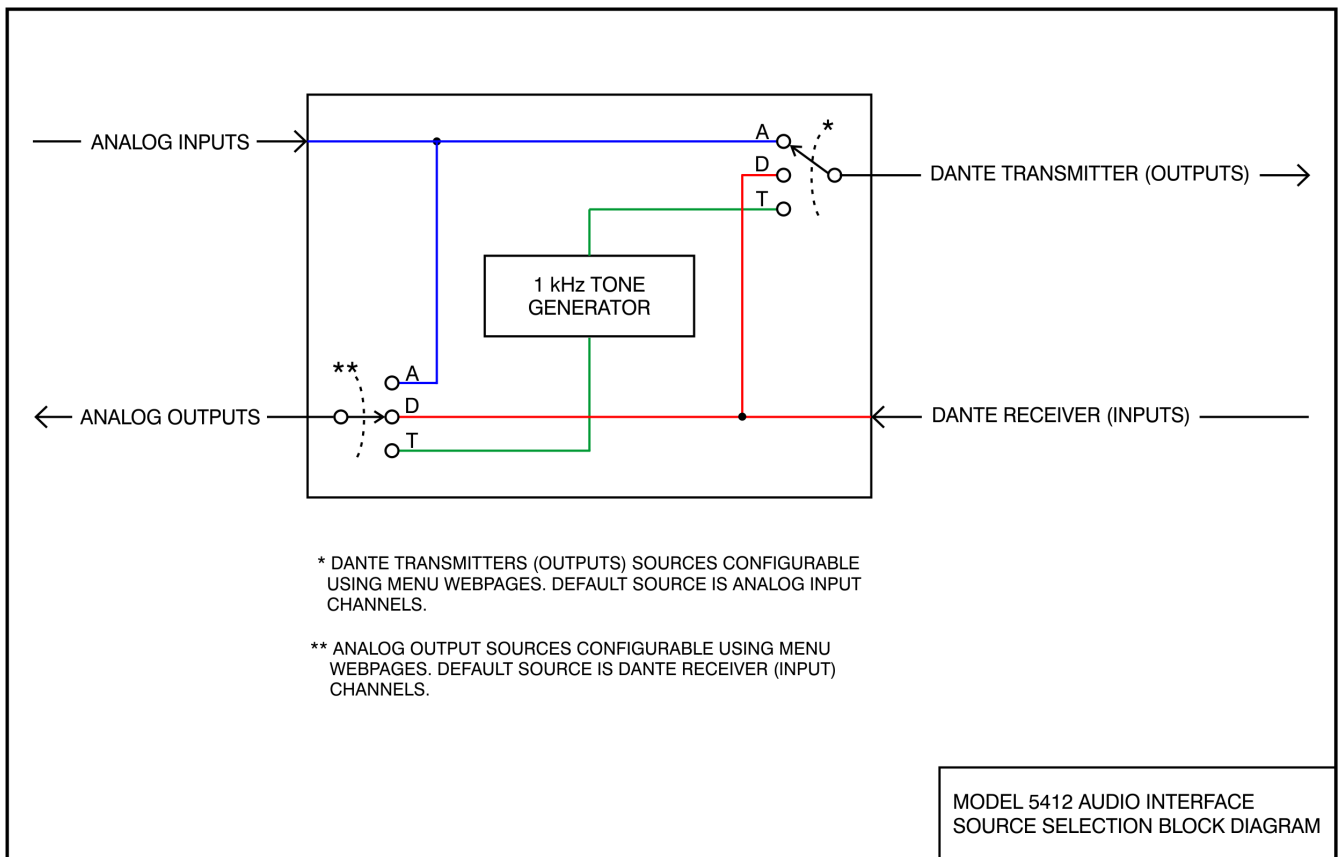

Appendix E – Front-Panel Menu Structure

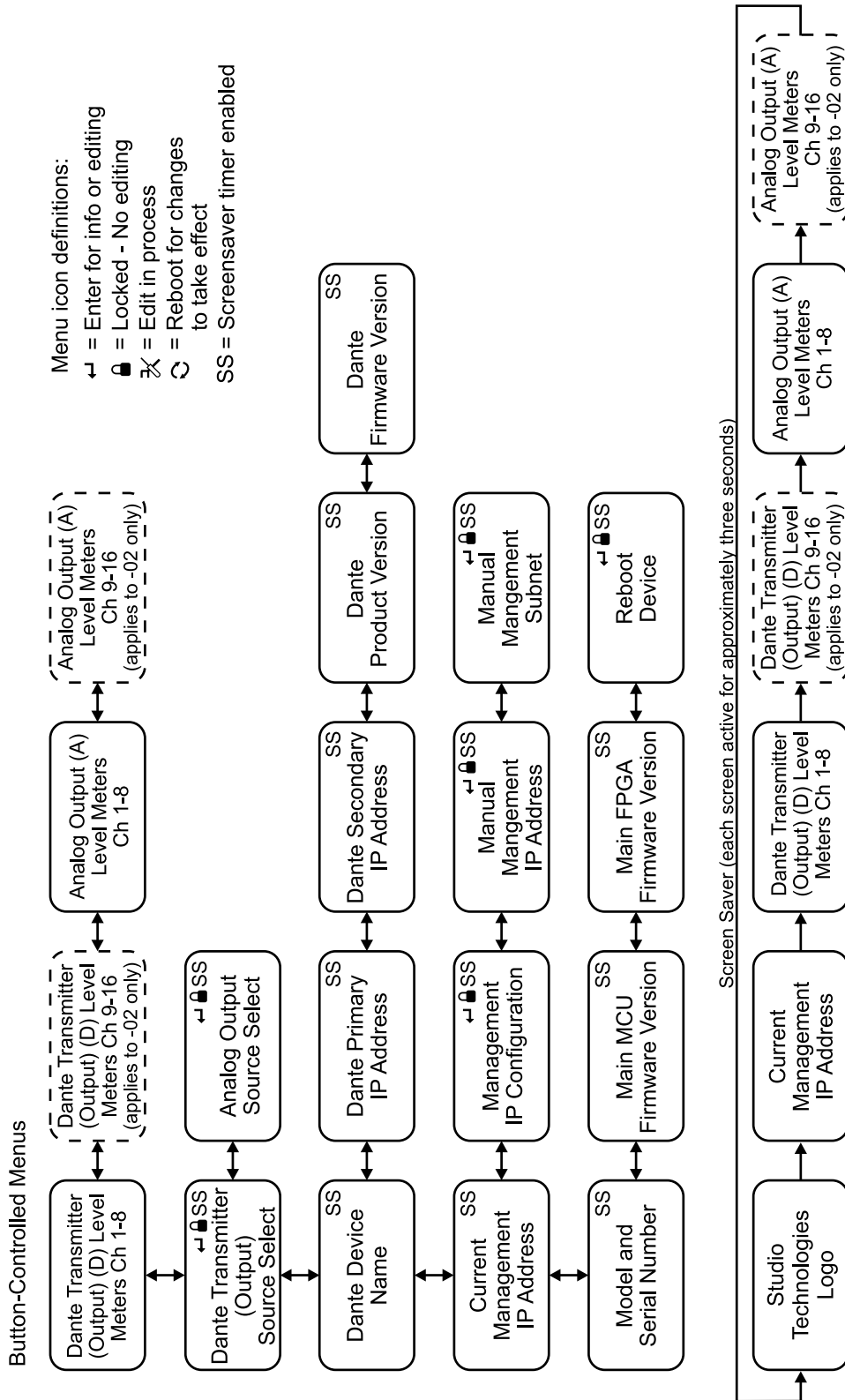

1. Screen saver automatically activates two minutes after last button press if displaying rows 2-5.
2. Press left and right buttons simultaneously to immediately enter screen saver mode.
3. Pressing Enter while screen saver is active goes to Current Management IP Address page.

Appendix F – Factory Default Values

Model 5412-01

Analog Inputs:

Level Adjustments (Channels 1-8): 0.0 dB
Dante Transmitters Source: Analog Inputs
Dante Transmitter 8 Source: Analog Input 8

Analog Outputs:

Level Adjustments (Channels 1-8): 0.0 dB
Analog Outputs Source: Dante Receivers

Network - Management Interface:

IP Address Configuration: Automatic
Manual IP Address: 192.168.1.12
Subnet Mask: 255.255.255.0
Gateway IP Address: 192.168.1.1

Access:

Front Panel Control: View/Edit
User Name: guest
Password: guest

Model 5412-02

Analog Inputs:

Level Adjustments (Channels 1-16): 0.0 dB
Dante Transmitters Source: Analog Inputs
Dante Transmitter 15 Source: Analog Input 15
Dante Transmitter 16 Source: Analog Input 16

Analog Outputs:

Level Adjustments (Channels 1-16): 0.0 dB
Analog Outputs Source: Dante Receivers

Network – Management Interface:

IP Address Configuration: Automatic
Manual IP Address: 192.168.1.12
Subnet Mask: 255.255.255.0
Gateway IP Address: 192.168.1.1

Access:

Front Panel Control: View/Edit
User Name: guest
Password: guest

Appendix G – Accessing Unit when User Name and/or Password are Not Known

Follow this procedure to access the Configuration menu webpages if the user name and/or password are not known.



1. Remove power from the Model 5412.
2. Press and hold the left arrow and Enter buttons.
3. While continuing to hold the two buttons apply AC Mains or 12 volts DC power.
4. Continue to hold the two buttons and allow the Model 5412 to start. The Status LEDs on the front panel will first light green then light red in their start-up sequence.
5. Once the Status LEDs have completed their start-up sequence release the two buttons.
6. Use a web browser to access the Model 5412's Configuration menu webpages. The management port's IP address to use is shown in the current management IP address page on the front-panel display. Pressing the Enter button will cause the current management IP address page to immediately show on the front-panel display.
7. From the Home webpage select the Login menu webpage tab. Leave the user name and password fields empty and click the Log In button. This will allow access to the Configuration menu selections. At this point your web browser should display the Model 5412's Home webpage.
8. Navigate to the Access menu. From this webpage you will be able to view the stored user name. You will not be able to view the previously saved password. Enter and confirm a new password. Henceforth, to access the Model 5412's Configuration menu will require the use of the stored user name and password.