

Model 204 Announcer's Console

User Guide

Issue 5, April 2026

This User Guide is applicable for serial numbers:

M204-00151 and later with
Application Firmware (.bin) version 2.2 and later
STcontroller version 3.11.27 and later

Copyright © 2026 by Studio Technologies, Inc., All rights reserved
studio-tech.com

Table of Contents

Revision History	3
Introduction	4
Getting Started.....	9
Dante Configuration.....	11
Model 204 Configuration.....	12
Operation	18
Technical Notes	23
Specifications.....	26
Appendix A – Model 204 Block Diagram.....	28
Appendix B – Model 204 STcontroller Default Configuration Values	29

Revision History

Issue 5, April 2026:

- Clarifies that Main Out Tally function is available only on units with serial numbers M204-00501 and later.
- Miscellaneous clarifications and corrections.

Issue 4, March 2021:

- Documents revisions and additions to Button Backlight modes.

Issue 3, August 2020:

- Documents addition of Main Out Tally function. (Applies only to serial numbers M204-00501 and later.)

Issue 2, October 2018:

- Documents addition of the Push to Mute/Tap to Latch main button operating mode.

Issue 1, May 2018:

- Initial release.

Introduction

The Model 204 Announcer's Console offers a unique combination of analog and digital audio resources for use in broadcast sports, eSports, live event, entertainment, and streaming broadcast applications. The unit is housed in a compact, rugged steel enclosure that's intended for tabletop use. Calling the Model 204 "cute" or "cool" would be accurate; its nicely proportioned but diminutive size makes it ideal for use in space-constrained locations. The Model 204 supports Dante® audio-over-Ethernet digital media technology with AES67 compatibility for integration into contemporary applications. The unit is extremely simple to deploy, is "pro" quality throughout, and provides an intuitive user experience. The Model 204's audio quality is excellent, with low distortion, low noise, and ample headroom. Careful circuit design and rugged components ensure long, reliable operation.

The Model 204 integrates directly into both Dante audio-over-Ethernet and standard analog audio environments. With just a Power over Ethernet (PoE) connection, a microphone, and a pair of headphones or an earpiece, a complete broadcast on-air position can be created. And by using the Model 204's microphone output a direct connection to an analog microphone-level input on an associated camera, remote I/O interface, or audio console can be supported. Two remote control inputs allow external switches or contact closures to activate the main and talkback button functions. One of the inputs can also be configured to provide a low-voltage DC "tally" output that follows the state of the main output.

Model 204 operating features are configured using the STcontroller software application. An extensive set of parameters allows the unit's functions to be tailored to meet the needs of many applications. STcontroller is a fast and simple means of confirming and revising the unit's operating parameters.

Applications

The Model 204 on its own can provide an "all-Dante" solution for one on-air talent location. A wide range of applications can be supported, including sports and entertainment TV and radio events, streaming broadcasts, corporate and government AV installations, and post-production facilities. The unit's small size makes it ideal for live-sports applications, such as basketball, where physical space for personnel is very limited. Four Dante receiver (input) audio channels supply the user with their talent cue (IFB) signals. Should the cue signal be "mix-minus" an integrated sidetone function can provide the user with a microphone confidence signal. Two Dante transmitter (output) audio channels, one designated as main and the other as talkback, are routed via an associated local-area network (LAN) to inputs on Dante-compatible devices. Two pushbutton switches, main and talkback, provide the user with direct control over audio routing. The audio switching is performed in the digital domain and is virtually "click-free."



Figure 1. Model 204 Announcer's Console front and rear views

By providing the main audio signal in two forms, Dante digital audio and analog microphone level, the Model 204 makes integration into a wide range of on-air environments easy to accomplish. The talkback audio channel is available as a Dante transmitter (output) channel which makes routing to an input on a variety of devices, such as matrix intercom systems, audio consoles, and monitor loudspeaker systems, simple and flexible.

Some applications may benefit from not utilizing the Model 204's Dante main output channel. This typically won't be an issue of inadequate audio quality but rather a need to match work-flow requirements. For example, for lip-sync or transmission purposes it may be optimal to have the on-air audio transported as an embedded signal along with the associated camera video. Alternately, all on-air audio sources may need to connect to inputs on an audio console or console-related I/O unit. Supporting these scenarios is not a problem as the Model 204 supplies a microphone output connection that's specifically intended for this purpose. Simply connect the unit's microphone output connection to the desired analog input, such as the mic/line input on an ENG-style camera—that's it!

The circuitry associated with the Model 204's analog microphone output is very simple, essentially a passive path that routes a signal connected to the microphone input connector directly to the microphone output connector. A solid-state circuit, in series with the mic in-to-mic out path, allows muting of the signal on the microphone output connector whenever the Dante main output channel is muted. Having both the Dante main output and the microphone outputs work in tandem can be a valuable resource, allowing one to serve as the primary on-air signal source while the other serves as the backup.

Setup and Operation

Set up, configuration, and operation of the Model 204 is simple. An etherCON® RJ45 jack is used to interconnect with a standard twisted-pair Ethernet port associated with a PoE-enabled network switch. This connection provides both power and bidirectional digital audio. A broadcast headset or handheld ("stick") microphone can be directly connected to the unit's 3-pin XLR mic input connector. The input is compatible with dynamic or condenser microphones. The integrated P48 phantom power source provides support for a wide range of condenser microphones. A 3-pin XLR microphone output connector provides a "direct mic out" function for integration with microphone inputs on related devices. Stereo headphones, the headphone connections from a stereo or monaural headset, or even a monaural earpiece can be connected to the phones output jack.

External switches or contact closures can be connected to the Model 204's remote control inputs to allow activation of the main and talkback button functions. For units with serial numbers 00501 and later, a low-voltage/low-current DC output can also be implemented providing a Main Out Tally function.

The STcontroller software application is used to configure the wide range of Model 204 operating parameters. This allows the unit's performance to be optimized to meet the needs of specific applications.

The user is presented with two pushbutton switches and three push-in/push-out rotary level potentiometers. This makes it easy to control the status of the main and talkback outputs as well as adjusting the signals that are sent to the headphone channels.

Ethernet Data and PoE

The Model 204 connects to a local area network (LAN) by way of a standard 100 Mb/s twisted-pair Ethernet interface. The physical 100BASE-TX interconnection is made by way of a Neutrik® etherCON RJ45 connector. While compatible with standard RJ45 plugs, etherCON allows a ruggedized and locking interconnection for harsh or high-reliability environments.

The Model 204's operating power is provided by way of the Ethernet interface using the 802.3af Power over Ethernet (PoE) standard. This allows fast and efficient interconnection with the associated data network. To support PoE power management, the Model 204's PoE interface enumerates (reports) to the power sourcing equipment (PSE) that it's a class 2 (low power) device.

Dante Audio-over-Ethernet

Audio data is sent to and received from the Model 204 using the Dante audio-over-Ethernet media networking technology. As a Dante-compliant device, the Model 204's two Dante transmitter (output) channels and four Dante receiver (input) channels can be assigned (routed or "subscribed") to other devices using the Dante Controller software application. The Dante transmitter (output) and receiver (input) channels are limited to supporting four Dante flows, two in each direction. The digital audio's bit depth is up to 24 with a sampling rate of 44.1 or 48 kHz. Two bi-color LEDs provide an indication of the Dante connection status. An additional LED displays the status of the associated Ethernet connection.

The Model 204 is compatible with the AES67 interoperability standard. In this mode, the two transmitter (output) channels will function in multicast; unicast is not supported. In addition, the unit is compatible with the Dante Domain Manager™ (DDM) software application.

Audio Quality

The Model 204's audio performance is completely "pro." A low-noise, wide dynamic-range microphone preamplifier and associated voltage-controlled-amplifier (VCA) dynamics controller (compressor) ensures that mic input audio quality is preserved while minimizing the chance of signal overload. The output of the microphone preamp and compressor is routed to an analog-to-digital conversion (ADC) section that supports sampling rates of 44.1 and 48 kHz with a bit depth of up to 24. The audio signal, now in the digital domain, routes through a 32-bit microprocessor and on to the Dante interface section where it is packetized and prepared for transport over Ethernet.

Audio signals arrive via the four Dante receiver (input) channels and pass into the Model 204's microprocessor. The supported sampling rates are 44.1 and 48 kHz with a bit depth of up to 24. Channel routing, headphone level control, and sidetone creation are performed within the digital domain. This provides flexibility, allows precise control, and keeps the three level potentiometers from having to directly handle analog audio signals. The audio channels destined for the phones outputs are sent to a high-performance digital-to-analog converter and then on to robust driver circuitry. High signal levels can be provided to a variety of headsets, headphones, and earpieces.

Configuration Flexibility

The Model 204 can be configured to meet the needs of specific applications and user preferences. All configuration choices are performed using the STcontroller software application. There are no mechanical switch settings or button-press sequences required to configure how the unit functions. Selectable parameters include microphone preamplifier gain, P48 phantom power on/off, button operation, remote control

inputs (including tally output), headphone output mode, sidetone operation, and overall unit operation. The gain of the microphone preamplifier can be selected from among four choices. This allows the Model 204 to match the output sensitivity of a range of handheld and headset-associated microphones. A low-noise source of P48 phantom power can be enabled if required to support condenser (capacitor) microphones.

The main and talkback pushbutton switches can be individually configured. The main button can be selected to operate from among five modes, while the talkback button can be selected from among three. These choices allow the Model 204's operation to be tailored to meet the specific needs of many applications. As an example, for on-air sports applications the main button would typically be configured to provide a push to mute (cough) function. The microphone signal on the Dante main output channel and the microphone output connector would remain active unless the talent needs to momentarily disable it. The talkback button would most likely be set to the push to talk mode as its use would be intermittent.

Red and green LEDs are associated with the main and talkback pushbutton switches. A configuration choice allows selection of the manner in which the LEDs will light under various operating conditions. This capability was specifically provided to assist users who have trouble observing the differences between colors, typically issues with red and green. "Color blindness" is not infrequently found in men and can make effective use of some electronic equipment difficult. In addition, the Model 204's ability to control the colors presented by the pushbuttons can be useful for international applications. Local preferences will often determine which color is associated with a function being "on" and which color is associated with a function being "off."

The Model 204 provides two remote control inputs. Configuration choices allow these inputs to be assigned to work in parallel with the main or talkback pushbutton switches. In this way, activation of a remote control input will emulate a user pressing its associated pushbutton switch. For units with serial numbers 00501 and later, Remote Control Input 1 can also be configured to provide a Main Out Tally function.

The audio sources and the way in which they are assigned to the headphone output channels can be configured from among five choices. These unique choices allow almost any required headphone monitoring situation to be implemented. Whether for use in on-air sports, an awards show broadcast, or as a production support tool, the Model 204 should be able to achieve the desired configuration.

Following the mode number is an abbreviated description of what signal or signals are assigned to the three potentiometers (pots) and on to the two headphone output channels. The potentiometers are labeled A, B, and C, as can be seen in Figure 1. The format would equate to Mode x – pot A/pot B/pot C where x equals the mode number.

- **Mode 1 – Ch1L/Ch2R/SidetoneLR:** Provided for broadcast applications where two monaural channels of talent cueing audio ("IFB") need to be independently sent to the left and right headphone output channels. It would be common for program audio with director interrupt to enter the Model 204 by way of Dante receiver input) channel 1 and be sent to the left headphone output. Program-only audio, entering the unit by way of Dante receiver (input) channel 2, would be sent to the right headphone output. Pots A and B are used to adjust the level of those signals. Pot C is used for the sidetone function where microphone audio is sent to both the left and right channels of the headphone output.

- **Mode 2 – Ch1LCh2R/BalanceLR/SidetoneLR:** Intended for applications where a stereo signal enters the Model 204 by way of Dante receiver (input) channels 1 and 2 and is routed to the left and right channels of the headphone output. In this mode, pot A controls the overall level of this stereo signal and pot B controls its left/right level balance. Pot C is used by the sidetone function.
- **Mode 3 – Ch1LCh2R/Ch3LCh4R/SidetoneLR:** Allows two stereo signals to be routed as stereo pairs to the two headphone output channels. In this mode, pot A adjusts the level of the stereo pair entering the unit by way of Dante receiver (input) channels 1 and 2 while pot B adjusts the level of the stereo pair entering on Dante receiver (input) channels 3 and 4. Pot C is used by the sidetone function.
- **Mode 4 – Ch1L/Ch2R/Ch3LCh4R:** Allows two monaural input signals to be independently routed to the left and right headphone output channels. These audio signals would enter the Model 204 by way of Dante receiver (input) channels 1 and 2. Pots A and B are used to control the levels of the signals as they are sent to the left and right headphone output channels. A stereo input signal, entering the unit by way of Dante receiver (input) channels 3 and 4, are routed to the left and right headphone outputs. This stereo pair has its level controlled by pot C.
- **Mode 5 – Ch1LR/Ch2LR/Ch3LCh4R:** Allows two monaural input audio channels to be sent to both the left and right headphone output channels. Dante receiver (input) channels 1 and 2 are used to bring these audio signals into the Model 204. Pots A and B are used to control the level of the signals as they are sent to the headphone output channels. Pot C is used to control the level of a stereo input signal as it is routed to the left and right channels of the headphone output. This stereo pair enters the unit by way of Dante receiver (input) channels 3 and 4.

The integrated sidetone function can be configured to operate from among four choices. This allows audio associated with the microphone input and microphone preamplifier to be returned to the headphone output. This is important as different applications may provide a “full mix” or a “mix-minus” talent cue signal. If a full mix cue signal is provided then sidetone audio will not be needed and the function can be disabled. In the case where a mix-minus signal is present, providing the user with sidetone at the appropriate time(s) can be an important means of confirming the signal that’s coming from the connected microphone.

The headphone gain range configuration helps to provide an optimized audio level to Model 204 users. The appropriate setting will depend on the specific audio sources provided to the unit as well as user preference.

Three system modes select the overall way in which the Model 204 functions. The on-air mode is optimized for applications where users will be on-air talent that must maintain strict separation between on-air and production audio channels. Other applications will benefit from the two available production modes.

Future Capabilities and Firmware Updating

The Model 204 was designed so that its capabilities and performance can be enhanced in the future. A USB connector, located on the unit’s main circuit board (underneath the unit’s cover), allows the application firmware (embedded software) to be updated using a USB flash drive.

The Model 204 uses the Audinate Ultimo™ integrated circuit to implement the Dante interface. The firmware in this integrated circuit can be updated via the Ethernet connection, helping to ensure that its capabilities remain up to date.

Getting Started

What's Included

Included in the shipping carton are a Model 204 Announcer's Console and instructions on how to obtain an electronic copy of this guide. As a device that is Power over Ethernet (PoE) powered, no external power source is provided.

Connections

In this section, signal interconnections will be made using the five connectors located on the back of the Model 204's enclosure. An Ethernet data connection with Power over Ethernet (PoE) capability will be made using either a standard RJ45 patch cable or an etherCON protected RJ45 plug. A microphone will be connected using a cable-mounted 3-pin male XLR connector. A set of headphones or an earpiece will be connected by way of a 1/4-inch plug. If desired, the Model 204's microphone-level output may be interfaced with other equipment using a cable terminated with a standard 3-pin female XLR connector. Special applications may utilize the two remote control inputs that are accessible using a 3-conductor 3.5 mm jack. Remote Control Input 1 can be configured such that it provides a tally output.

Ethernet Connection with PoE

A 100BASE-TX Ethernet connection that supports Power over Ethernet (PoE) is required for Model 204 operation. This one connection will provide both the Ethernet data interface and power for the Model 204's circuitry. A 10BASE-T connection is not sufficient and a 1000BASE-T (GigE) connection is not supported unless it can automatically "fall back" to 100BASE-TX operation. The Model 204 supports Ethernet switch power management, enumerating itself as a PoE class 2 device.

The Ethernet connection is made by way of a Neutrik etherCON protected RJ45 connector that is located on the back of the Model 204's enclosure. This allows connection by way of a cable-mounted etherCON connector or a standard RJ45 plug. The Model 204's Ethernet interface supports auto MDI/MDI-X so that a "cross-over" or "reversing" cable will never be required.

Microphone Input

The Model 204 provides a 3-pin female XLR connector that allows a balanced dynamic or phantom powered condenser microphone to be connected. The microphone can be a standalone handheld ("stick") type or can be part of a broadcast-style headset. The Model 204's microphone input is directly compatible with balanced dynamic or P48 phantom powered microphones. A microphone should be connected such that its associated XLR connector has pin 1 as common, pin 2 as signal high (+), and pin 3 as signal low (-). A configuration setting in STcontroller allows the P48 phantom power source to be enabled or disabled as desired. Details on configuration settings will be described later in this guide.

While the Model 204 provides an excellent source of P48 phantom power, it's possible that an input on an associated piece of equipment is already providing microphone power. This could be connected to the Model 204 by way of the microphone output connector. This would not create a problem since the circuitry that connects audio from the Model 204's microphone output connector to the Model 204's microphone input connector will pass this microphone power through without interruption. This situation could be relevant when the Model 204's microphone output connector is interfaced with the microphone input on a broadcast camera, audio console, microphone mixer, or similar equipment. Inputs on these devices would typically offer phantom power which in some cases may have been enabled.

Headphone Output

The Model 204 provides a 2-channel headphone output interfaced by way of a 3-conductor ¼-inch phone jack. Devices such as stereo headphones or stereo (“dual-muff”) broadcast-style headsets can be directly connected using a 3-conductor ¼-inch plug. Following the usual convention the left channel should be terminated on the tip lead, the right channel on the ring lead, and common on the sleeve lead.

It's also possible to use a monaural (“single-muff”) headset or broadcast-type single earbud. In these cases, care must be taken. If a 3-conductor ¼-inch plug is used by a device it should be wired to the tip and sleeve leads; the plug's ring lead should be left unconnected. But it's also possible that the monaural device will be terminated on a 2-conductor (“tip and sleeve”) plug. When the plug is inserted into the Model 204's headphone jack the Model 204's right headphone output channel will be shorted; the ring lead will be directly connected to the sleeve lead. This can lead to stress on the right channel headphone output circuitry as well as extra current draw. To prevent this undesirable condition ensure that no input audio signal is routed to the right headphone output channel. Refer to the Configuration section for details on setting the headphone audio routing to best accomplish this condition.

Microphone Output

A 3-pin male XLR connector provides a microphone-level output that's directly related to the microphone input. Technically the output is identical to the signal that's connected to the microphone input but with a solid-state muting circuit in series with the interconnection. When the Model 204's Dante main output channel is active the microphone signal will also pass through to the Model 204's microphone output connector. Whenever the Dante main output channel is muted the microphone signal does not pass through to the microphone output connector; it is muted in an essentially click-free manner. Refer to Appendix A for a block diagram of the microphone input and microphone output circuitry.

The microphone output can be connected to balanced (differential) analog microphone-level inputs on a variety of devices. This includes microphone input connections on remote I/O interfaces associated with a networked audio console. An example of such an interface would be the Calrec® Hydra2®. The mic inputs on these devices typically offer microphone power, high-quality amplification, and conversion to the digital domain. The output signals of the interface's pre-amp channels are transported to the main electronics or console surface using a fiber optic interface. In this type of application, the Model 204's Dante main output channel would not be used or would only be used as a backup path.

No preamplifier or other active circuitry impacts the path from the Model 204's microphone input connector to the Model 204's microphone output connector. But the signal does pass through a 200 ohm resistor in each “leg” (pin 2 and pin 3) along with connecting to a solid-state relay contact. The result is that the source impedance of a connected microphone will be 400 ohms greater when presented to the microphone output connector. This will slightly raise the theoretical noise floor of the microphone signal vis-à-vis a directly connected microphone signal but shouldn't impact any real-world applications.

Remote Control Inputs

Provision has been made to allow external switches or contact closures to mimic operation of the main and talkback pushbutton switches. The exact functioning of the two remote control inputs is determined by configuration settings, details of which are discussed later in this guide. A 3-conductor 3.5 mm jack is located on the Model 204's back panel and provides access to the two remote control inputs. The input

circuitry is “active low,” with 3.4 k ohm resistors connected to +3.3 volts DC to act as input “pull ups.” (In addition, a combination of resistors and capacitors provide ESD protection, minimizing the chance of damage due to static discharge or other extraneous signals.) A current flow of less than one milliamperere is required for a remote control input to be recognized as active.

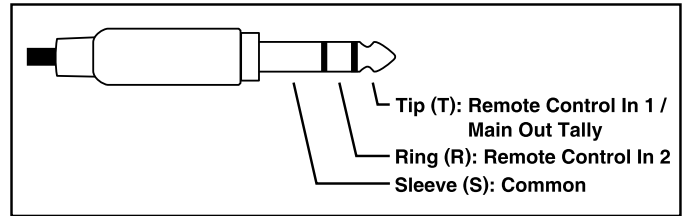

Figure 2. 3-conductor (TRS) 3.5 mm plug configured for use with remote control inputs

For units with serial numbers 00501 and later, Remote Control Input 1 can also be configured to provide a Main Tally Output function. This will provide a 3.3 volts DC, 23 milliamperere maximum output whenever the main output function is active. The tally output can directly drive an LED or be utilized by the input on another piece of equipment.

Prepare the interconnecting cable and associated 3-conductor (TRS) 3.5 mm plug to reflect that the tip lead is used by Remote Control Input 1, the ring lead by Remote Control Input 2, and the sleeve lead is the connection to common. Refer to Figure 2 for connection details.

Dante Configuration

For audio to pass to and from the Model 204 requires that several Dante-related parameters be configured. These configuration settings will be stored in non-volatile memory within the Model 204's circuitry. Configuration will typically be done with the Dante Controller software application which is available for download free of charge at audinate.com. Versions of Dante Controller are available to support Windows and OS X® operating systems. The Model 204 uses the Ultimo integrated circuit to implement the Dante functionality. The Model 204 can also be configured to meet the requirements of the AES67 standard. This requires a setting to be enabled within the Device Info section of the Dante Controller application.

The two Dante transmitter (output) channels associated with the Model 204's Dante interface must be assigned to the desired receiver (input) channels on associated equipment. This achieves routing of the Model 204's two audio output channels to the device (or devices) that will be “listening” to them. Within Dante Controller a “subscription” is the term used for routing a transmitter flow (a group of up to four output channels) to a receiver flow (a group of up to four input channels). The number of transmitter flows associated with an Ultimo integrated circuit is limited to two. These can either be unicast, multicast, or a combination of the two. If the Model 204's Dante transmitter (output) channels need to be routed to more than two flows it's possible that an intermediary device with enhanced flow capability, such as the Studio Technologies' Model 5422A Dante Intercom Audio Engine, can be used to “repeat” the signals.

The desired audio sources need to be routed to the Dante receiver (input) channels associated with the Model 204. The unit provides four audio input channels. The number utilized will depend on the specific application. Following the unit's headphone source and routing configuration selection these audio signals will be sent to the Model 204's 2-channel headphone output.

The Model 204 supports audio sample rates of 44.1 and 48 kHz with no pull-up/pull-down values available. In most cases, it's anticipated that the default rate of 48 KHz will be appropriate. While technically the Model 204 can serve as a Leader Clock for a Dante network (as can all Dante-enabled devices) in virtually all cases, the unit will be configured to receive “sync” from another device.

The Model 204 has a default Dante device name of **ST-M204-** along with a unique suffix. The suffix identifies the specific Model 204 that is being configured. The suffix's actual alpha and/or numeric characters relate to the MAC address of the unit's Ultimo integrated circuit. The two Dante transmitter (output) channels have default names of **Main** and **Talkback**. The four Dante receiver (input) channels have default names of **Headphone Ch1**, **Headphone Ch2**, **Headphone Ch3**, and **Headphone Ch4**. Using Dante Controller the default device name and channel names can be revised as appropriate for the specific application.

Model 204 Configuration

The STcontroller software application is used to configure the way in which the Model 204 functions. No DIP switch settings or other local actions are used to configure the unit. This makes it imperative that STcontroller be available for convenient use in a personal computer that's connected to the related LAN.

Installing STcontroller

STcontroller is available free of charge on the Studio Technologies' website. If required, download and install STcontroller onto a designated personal computer. This personal computer must be on the same local area network (LAN) and subnet as the Model 204 unit or units that are to be configured. Immediately after starting STcontroller the application will locate the devices that it can control. The one or more Model 204 units to be configured will appear in the device list. Use the *Identify* command to allow easy recognition of a specific Model 204 unit. Double-clicking on a device name will cause the associated configuration menu to appear. Review the current configuration and make any changes that are desired.

The configurable functions include:

- P48 phantom power on/off status
- Microphone input gain
- Headphone audio sources and routing
- Headphone gain range and minimum level
- Sidetone
- Main and talkback button operating modes
- System operating mode
- Remote control inputs
- Button backlight modes

Changes made using STcontroller will be immediately reflected in the unit's operation; no Model 204 "reboot" is required. Each time a change is made the main and talkback buttons on the front panel will momentarily flash orange in a distinctive pattern to indicate that a command from STcontroller has been received.

P48 Phantom Power

STcontroller allows selection of the on/off status of the microphone input's P48 phantom power source. The on/off status is displayed by way of an LED, red in color, located on the back panel adjacent to the

microphone input connector. Select the status of the P48 source to meet the needs of the connected microphone. No problem will occur if an external source of P12 or P48 phantom power is present on the connection made to the microphone output connector. In this case, simply turn off the Model 204's P48 phantom power source. The external source of microphone power will "pass thru" from the microphone output connector to the microphone input connector.

Microphone Input Gain

The gain of the Model 204's microphone preamplifier can be selected from among four choices: 35, 43, 52, and 59 dB. The compressor active LED, orange in color and visible on the back of the Model 204's enclosure adjacent to the microphone input connector, can act as a guide when setting the preamp gain. When a voice signal at a normal level is present on the microphone input the compressor active LED should light intermittently. If, for example, it rarely lights and the gain is set to 43 dB, it might be a good idea to change the setting to 52 dB. If the LED is lit fully during normal talking and the gain is set for 52 or 59 dB, changing it to one of the lower values might be warranted. There's no "hard and fast" rule about which gain setting is appropriate. But unless otherwise indicated, 43 dB is typically a good initial choice.

Headphone Audio Sources and Routing

STcontroller allows selection from among five headphone audio source and routing modes. Each mode is distinct and careful selection will help optimize the Model 204's operation for a range of applications.

- **Mode 1 – Ch1L/Ch2R/SidetoneLR:** Mode 1 is provided for on-air applications where two independent audio sources need to be routed separately to the two headphone output channels. Dante receiver (input) channel 1 will be routed to the left headphone output channel and pot A will adjust its level. Dante receiver (input) channel 2 will be routed to the right headphone output channel and pot B will adjust its level. Pot C will adjust the level of the sidetone audio as it is sent to both the left and right headphone output channels.
- **Mode 2 – Ch1LCh2R/BalanceLR/SidetoneLR:** Mode 2 is provided for stereo applications that could include live music events that are distributed via streaming audio or by way of an over-the-air broadcast. In these applications it's typical to want the user to have a single potentiometer to simultaneously adjust the level of a stereo pair while a separate potentiometer is used to adjust the left/right level balance.

When set for mode 2 Dante receiver (input) channel 1 will be routed to the left headphone output channel and Dante receiver (input) channel 2 will be routed to the right headphone output channel. Pot A will adjust the overall level of both headphone output channels. Pot B will adjust the level balance between the left and right output channels. Pot C will adjust the level of the sidetone audio as it is sent to both the left and right headphone output channels.

- **Mode 3 – Ch1LCh2R/Ch3LCh4R/SidetoneLR:** Mode 3 can be useful in applications where two stereo signals need to be provided to the user on the left and right headphone output channels. In this mode, Dante receiver (input) channels 1 and 2 are routed to the left and right channels of the headphone output. Pot A adjusts the level of this stereo pair. Dante receiver (input) channels 3 and 4 are also routed to the left and right channels of the headphone output. Pot B adjusts the level of this stereo pair as it is sent to the headphone output channels. Pot C will adjust the level of the sidetone audio as it is sent to both the left and right headphone output channels.

- **Mode 4 – Ch1L/Ch2R/Ch3LCh4R:** Mode 4 is very similar to mode 1 except instead of providing sidetone another stereo pair can be routed to the left and right headphone output channels. Dante receiver (input) channel 1 is routed to the left channel of the headphone output. Pot A adjusts its level. Dante receiver (input) channel 2 is routed to the right headphone output channel and pot B adjusts its level. A stereo pair can enter the Model 204 by way of Dante receiver (input) channels 3 and 4. These signals, whose level is adjusted using the pot C, are sent to the left and right channels of the headphone output.
- **Mode 5 – Ch1LR/Ch2LR/Ch3LCh4R:** Model 5 is a unique variation where two monaural signals can be routed to both the left and right headphone output channels while a stereo input source is routed in stereo to the headphone output channels. Dante receiver (input) channel 1 will be routed to both the left and right channels of the headphone output. Its level is controlled by pot A. Dante receiver (input) channel 2 will also be routed to both the left and right channels of the headphone output. Its level will be adjusted using pot B. A stereo pair can enter the Model 204 by way of Dante receiver (input) channels 3 and 4. These signals will be sent, in stereo, to the left and right channels of the headphone output. Their level will be adjusted using pot C.

Headphone Gain Range

The overall level of the headphone output can be configured as desired for specific applications. The default setting, low, is designed so that users with typical audio input sources will be inclined to set the rotary potentiometers at approximately 50% of rotation. This would be appropriate for most applications. The high setting would be applicable in cases where an extreme headphone output level is required or the audio input sources are providing a level that is lower than typical. Using the high setting in the former application is not recommended as hearing damage could result from exposure to high signal levels.

Headphone Minimum Level

A setting in STcontroller is used to configure the headphone output's minimum level. In the –40 dB setting the minimum headphone output level is approximately 40 dB below its maximum; the headphone output channels will never fully mute. This ensures that any audio signal present on the utilized Dante receiver (input) channels will always be present on the headphone output. In most on-air broadcast applications this is the appropriate setting, ensuring that a minimum amount of signal is always present. When full mute is selected, moving a level potentiometer to its fully counterclockwise position will cause its associated headphone output channel (or channels) to fully mute. If a potentiometer is set to serve as a balance control, moving it to either its fully counterclockwise or fully clockwise position will cause the associated signal to fully mute. Selecting the full mute mode may be appropriate for applications where minimizing the chance of audio “leakage” is important. This could occur when during an event the connected headset or headphones are at times placed on a desk or tabletop.

Note that the action of pot C, when configured to provide the sidetone function (headphone modes 1, 2 or 3), will never be impacted by the setting for the headphone minimum level. Whenever pot C is controlling the sidetone level it will always cause the signal to fully mute when it's set to fully counterclockwise.

Sidetone Mode

STcontroller allows the Model 204's sidetone function to be configured as desired. Sidetone is audio from the microphone input that is sent to the headphone output channels. This can be important, allowing the user to “hear” themselves for performance confirmation and comfort. Making a specific selection from

among the four available modes will depend on the needs of the application. If a “full mix” is being provided to the Model 204’s Dante receiver (input) channels then locally provided sidetone won’t be needed and the off configuration should be selected. The user will hear themselves by way of audio signals being routed to the Dante receiver (input) channels. But if “mix-minus” audio is being supplied to the Model 204 then selecting a headphone source and routing modes which enables sidetone (headphone modes 1, 2, or 3) can be an important means of establishing user confidence. The sidetone mode configuration will then establish exactly when sidetone audio will be sent to the headphone output channels.

Four sidetone modes are available:

- **Off:** In this mode, the sidetone function is not active.
- **Main Button:** In this mode, the sidetone function will be active whenever the audio signal associated with the microphone input is present on the Dante main output channel and the microphone output connector.
- **Talkback Button:** In this mode, the sidetone function will be active whenever the talkback function is active and the audio signal is present on the talkback Dante transmitter (output) channel.
- **Main and Talkback Buttons:** In this mode, the sidetone function will be active whenever the audio signal associated with the mic input is present on the Dante main output channel and the microphone output connector. The sidetone function will also be active whenever the talkback function is active.

Button Operation – Main

STcontroller allows the configuration of the main button to be selected. There are five mode choices available:

- **Push to Mute:** If this mode is selected, the main button function will normally be active. The audio signal associated with the microphone input will be routed to both the Dante main output channel and the microphone output connector. Whenever the main button is pressed, the audio signal will mute on both the Dante main output channel and the microphone output connector.
- **Push to Talk:** If this mode is selected, the main button function will normally be inactive. The audio signal associated with the microphone input will be muted on both the Dante main output channel and the microphone output connector. Whenever the main button is pressed, the audio signal will become active on both the Dante main output channel and the microphone output connector.
- **Latching:** If this mode is selected, the main button’s function will alternate between its active and inactive states whenever the main button is pressed. Upon power up, the function will be in its inactive state.
- **Push to Talk/Tap to Latch:** This mode is a combination of the Push to Talk and Latching modes. It’s similar to the way talk pushbutton switches function on user stations associated with broadcast or production intercom systems. If the main button is pressed and held, the main button’s function will be active. It will stay active until the main button is released. If the main button is momentarily “tapped,” the main button’s status will change, either from inactive-to-active or from active-to-inactive. Upon Model 204 power up, the main button function will be in its inactive state.

- **Push to Mute/Tap to Latch:** This mode is a combination of the Push to Mute and Latching modes. Whenever the main button is momentarily “tapped,” the main button’s status will change, either from active-to-inactive or inactive-to-active. The audio signal associated with the microphone input will be routed to both the Dante main output channel and the microphone output connector. Whenever the main button is pressed and held, the audio signal will mute on both the Dante main output channel and the microphone output connector. It will stay in this condition until the main button is released. Upon Model 204 power up, the main button function will be in its inactive state.

Button Operation – Talkback

The manner in which the talkback button functions can be configured. There are three mode choices available:

- **Push to Talk:** If this mode is selected, the talkback function will normally be inactive and the LED associated with the talkback button will not be lit. Whenever the talkback button is pressed, the talkback function will become active and depending on the unit’s configuration, the button’s green or red LED will light.
- **Latching:** If this mode is selected, the talkback function will alternate between the active and inactive state whenever the talkback button is pressed. Upon power up, the talkback function will be in its inactive state and its button LED will not be lit.
- **Push to Talk/Tap to Latch:** This mode is a combination of the Push to Talk and Latching modes. It’s similar to the way talk pushbutton switches function on user stations associated with broadcast or production intercom systems. If the talkback button is pressed and held, the talkback function will be active. It will stay active until the talkback button is released. If the talkback button is momentarily “tapped,” the status of the talkback function will change, either from inactive-to-active or from active-to-inactive. Upon Model 204 power up, the talkback button will be in its inactive state and its LED will not be lit.

System Operating Mode

The system mode configures the overall manner in which the Model 204 operates. Specifically, it determines how the Dante main output channel and the microphone output connector operate vis-à-vis the talkback function. The system mode can also impact one facet of the headphone output’s function. There are three system modes available. Understanding how each specifically impacts Model 204 operation will help to ensure that the desired operation is obtained and that maximum usability will occur.

- **On-Air:** When selected to the *On-Air* mode, audio on the Dante main output channel and the microphone output connector will always mute whenever the talkback function is active. The on-air mode should be selected for all on-air broadcast applications when it’s imperative that the “on-air” audio signal be muted whenever on-air talent uses the talkback function to communicate with production personnel.
- **Production:** When the system mode is set for *Production*, the audio signals on the Dante main output channel and microphone output connector are never muted in response to talkback function activity. The mic off/off function operates independently of the talkback function. This mode allows the Dante main output channel to be used, for example, as an additional talkback output. In this way, the Dante main output channel and the talkback output channel can be used separately and not impact each other. This also allows both the main and talkback pushbuttons to be used simultaneously. When selected for the correct application, the production mode can prove to be very useful. But it’s not appropriate for on-air use!

- **Production with Dim:** This mode is identical to the production mode with the exception that the headphone output reduces in level (“dims”) whenever the main or talkback functions are active. This mode was specifically provided to minimize the chance that acoustical feedback will occur in applications where the headphone output is connected to the inputs on amplified speakers (or inputs on an amplifier associated with loudspeakers). In this mode, the level of the headphone output channels is reduced by 18 dB whenever the main or talkback function is active. This mode is not appropriate when headphones are going to be connected to the Model 204!

Remote Control Inputs

There are two remote control inputs which can be individually configured. Remote Control Input 1 can be configured to be disabled (off), to mimic the action of either the main or talkback pushbutton switches, or to provide a main output tally function. Remote Control Input 2 can be configured to be disabled (off), or mimic the action of either the main or talkback pushbutton switches.

Button Backlight Mode

Choices include *Standard – High*, *Standard – Low*, *Standard – High – Off When Inactive*, *Reverse – High*, *Reverse – Low*, and *Reverse – High – Off When Inactive*.

The Model 204’s pushbutton switches contain red and green LEDs that are used to provide an indication of a function’s status. The word *Standard* in a choice’s title means that red is utilized to indicate that a function is not active (off) and green is utilized to indicate that a function is active (on). The word *Reverse* in a title means that green is utilized to indicate when a function is not active (off) and red when a function is active (on).

The word *High* in a choice’s title means that the intensity of both the red and green LEDs are at the Model 204’s maximum. The word *Low* in a choice’s title means that the intensity is at a reduced level. The amount of ambient light present at the Model 204’s location will typically be the determining factor when selecting the LED intensity.

Off When Inactive relates to the action of the LEDs when the main output function is not active (off). Traditionally, an LED is lit in the pushbutton switch to indicate that the function is in its inactive, off, standby, or ready-to-use state. To assist users who have trouble with color discrimination (“color blindness”) the main pushbutton can be configured to not be lit when the function is not active (off). In this case, only when the function is active (on) will an LED light in the pushbutton switch.

- **Standard – High:** In this mode, the operation of the LEDs in the main and talkback buttons will match the way in which Studio Technologies has implemented this for many years. When the main output function is in its inactive (off) state the main button’s red LED will be lit. When the main output function is in its active (on) state the main button’s green LED will light. When the talkback function is in its inactive (off) state neither of the talkback button’s LEDs will be lit. When the talkback function is in its active (on) state the talkback button’s green LED will light. The intensity of the LEDs will be at their maximum.
- **Standard – Low:** The operation is the same as *Standard – High* except the intensity of the LEDs will be significantly lower.

- **Standard – High – Off When Inactive:** This mode is offered to assist users who have a reduced ability to discriminate between the colors red and green. In this mode, when the main output function is in its inactive (off) state neither of the main button's LEDs will be lit. When the main output function is in its active (on) state the main button's green LED will light. When the talkback function is in its inactive (off) state neither of the talkback button's LEDs will be lit. When the talkback function is in its active (on) state the talkback button's green LED will light. The intensity of the LEDs will be at their maximum.
- **Reverse – High:** In this mode, when the main output function is in its inactive (off) state the main button's green LED will be lit. When the main output function is in its active (on) state the main button's red LED will light. When the talkback function is in its inactive (off) state neither of the talkback button's LEDs will be lit. When the talkback function is in its active (on) state the talkback button's red LED will light. The intensity of the LEDs will be at their maximum.
- **Reverse – Low:** The operation is the same as Reverse – High except the intensity of the LEDs will be significantly lower.
- **Reverse – High – Off When Inactive:** This mode is also intended to offer “color blind” users an enhanced ability to determine the state of the main output function. When the main output function is in its inactive (off) state neither of the main button's LEDs will be lit. When the main output function is in its active (on) state the main button's red LED will light. When the talkback function is in its inactive (off) state neither of the talkback button's LEDs will be lit. When the talkback function is in its active (on) state the talkback button's red LED will light. The intensity of the LEDs will be at their maximum.

Operation

At this point all connections and configuration steps should have been completed and everything should be ready for Model 204 operation to commence. An Ethernet connection with Power over Ethernet (PoE) capability should have been made. A microphone and headphones or earbud should have been connected. Alternately, a broadcast-style headset may have been connected. If desired, a connection to the microphone output should have been made. Some applications may utilize either or both of the remote control inputs. Remote Control Input 1 can provide a low-voltage DC tally output that is active whenever the main output function is active. It may be used to light a status LED or trigger the input on another piece of equipment.

The Model 204 should have been placed in the desired physical location. Using the Studio Technologies' STcontroller software application the unit's configuration should have been selected to meet the needs of the specific application. The Model 204's Dante configuration settings should have been selected using the Dante Controller software application. In this way, the unit's two Dante transmitter (output) channels and four Dante receiver (input) channels should have been routed, by way of Dante “subscriptions,” to the receiver and transmitter channels on associated Dante-enabled equipment.

Initial Operation

The Model 204 will start to function as soon as a Power over Ethernet (PoE) power source is connected. However, it may take 20 to 30 seconds for full operation to commence. Upon initial power up, the three status LEDs, located on the back panel below the RJ45 jack, will begin to light as network and Dante connections are established. The COMP LED, adjacent to the microphone input connector, may or may not flash momentarily. The P48 LED, also located adjacent to the microphone input connector, will flash

once to indicate that it is functioning. The red and green LEDs within the main and talkback pushbutton switches will light in a short test sequence to indicate that the application firmware (embedded software) has started. Once that sequence has completed and the Dante connection has been established full operation will begin. The various LEDs will then become operational, displaying the status of their designated functions.

How to Identify a Specific Model 204

Functions within the Dante Controller and STcontroller software applications allow a specific Model 204 unit to be identified. Each application provides an “eyeball” icon that when clicked will activate the *Identify* function. When *Identify* is selected, it will send a command to a specific Model 204 unit. On that unit, the LEDs associated with the main and talkback pushbutton switches will “flash” orange approximately eight times (the actual on/off status of the buttons will not change). In addition, the SYS and SYNC status LEDs, located directly below the etherCON RJ45 connector on the back panel, will slowly flash green. After a few seconds the LED identification pattern will cease and normal Model 204 button LED and Dante status LED operation will resume.

Ethernet and Dante Status LEDs

Three status LEDs are located below the etherCON RJ45 connector on the Model 204's back panel. The LINK ACT LED will light green whenever an active connection to a 100 Mb/s Ethernet network has been established. It will then flash in response to all Ethernet data packet activity. The SYS and SYNC LEDs display the operating status of the Dante interface and its associated network activity. The SYS LED will light red upon Model 204 power up to indicate that the Dante interface is not ready. After a short interval it will light green to indicate that it is ready to pass data with another Dante device. The SYNC LED will light red when the Model 204 is not synchronized with a Dante network. It will light solid green when the Model 204 is synchronized with a Dante network and an external clock source (timing reference) is being received. It will slowly flash green when this specific Model 204 is part of a Dante network and is serving as the Leader Clock. It's possible that up to 30 seconds may be required for the SYNC LED to reach its final state.

P48 Status LED

An LED indicator is located on the back panel adjacent to the microphone input connector. It is labeled P48 and will light red whenever the P48 phantom power source is active and providing power to the microphone input.

Compressor Active LED and Mic Preamp Gain

An LED indicator, orange in color, is located on the back panel, also adjacent to the microphone input connector. It is labeled COMP and displays the status of the microphone audio compressor function. This function controls the dynamic range of the audio signal that can be present on the Dante transmitter (output) channels and sidetone audio sent to the headphone output versus the signal present on the microphone input. The compressor LED will light whenever the input level from the microphone, along with the configured microphone preamplifier gain, is such that the dynamic range of the signal is being actively controlled. It's perfectly acceptable for this LED to light intermittently whenever a user is talking at a normal voice level into an associated microphone. But if the COMP LED lights solid while a user is talking at a normal voice level this will typically indicate that the microphone preamplifier gain setting should be reduced. Conversely, if the COMP LED almost never lights when normal talking is taking place, it's

possible that changing the gain to a higher value would be beneficial. Note that due to the design of the circuitry the compressor active LED will function whether or not the main or talkback functions are active. Also, the compressor function does not impact the microphone output connector.

Main and Talkback Buttons

Two pushbutton switches are used to select how the microphone signal is routed to the two Dante transmitter (output) channels and the microphone output connector. The button labeled MAIN controls if the audio signal associated with the microphone input will be present on the Dante main output channel and the microphone output connector that's located on the back panel of the Model 204. When the function associated with the main button is active (on) audio will be present on both the Dante main output channel and the microphone output connector. When the function is inactive (off) audio will not be present on the Dante main output channel and the audio signal associated with the microphone output connector will be muted.

How the button specifically functions and what LED color and action is associated with it depends on the configuration choice that has been made using STcontroller. When the main output function is inactive (off) the pushbutton switch's LED can be lit red or green, or not lit at all. When the main output function is active (on) the pushbutton switch's LED will be lit red or green.

The talkback function allows the audio associated with the microphone input to be routed to the Dante talkback output channel. When the talkback function is active either its green or its red LED will be lit. How the talkback button specifically functions, the LED color that lights, and whether it impacts the main button's functioning depends on the Model 204's system configuration.

Main Button Modes

There are five ways that the main pushbutton switch can function. The way in which it specifically operates depends on its selected configuration.

- **Push to Mute:** If this mode is selected, the audio signal associated with the microphone input will normally be active on the Dante main output channel and the microphone output connector. The audio signal will mute whenever the main pushbutton is pressed and held.
- **Push to Talk:** If this mode is selected, the audio signal associated with the Dante main output channel and the microphone output connector will be normally muted. The audio signal will become active whenever the main pushbutton is pressed and held.
- **Latching:** If this mode is selected, the audio signal associated with the Dante main output channel and the microphone output connector will alternate between their active and muted states whenever the main pushbutton is pressed. Upon Model 204 power up, the audio signal will be in its muted state.
- **Push to Talk/Tap to Latch:** This mode is a combination of the Push to Talk and Latching actions. It's similar to the way in which talk pushbuttons function on user stations associated with broadcast or production intercom systems. If the main pushbutton is pressed and held, the audio signal associated with the Dante main output channel and the microphone output connector will become active and remain active until the pushbutton is released. If the main pushbutton is momentarily "tapped," the audio signal will change state. Upon Model 204 power up, the audio signal will be in its muted state.

- **Push to Mute/Tap to Latch:** This mode is a combination of the Push to Mute and Latching modes. Whenever the main button is momentarily “tapped,” its status will alternate between active and muted. When the main button’s function is active and the main button is pressed and held, the audio signal will mute on both the Dante main output channel and the microphone output connector. It will stay in this condition until the main button is released. Upon Model 204 power up, the audio signal will be in its muted state.

Talkback Button Modes

Depending on the selected configuration, the talkback pushbutton will function in one of three possible modes:

- **Push to Talk:** If this mode is selected, the audio signal associated with the Dante talkback output channel is normally muted. The audio signal will become active whenever the talkback pushbutton is pressed and held.
- **Latching:** If this mode is selected, the audio signal associated with the Dante talkback output channel will alternate between its active and muted state whenever the talkback pushbutton is pressed. Upon Model 204 power up, the Dante talkback output channel will be in its muted state.
- **Push to Talk/Tap to Latch:** This mode is a combination of the Push to Talk and Latching actions. If the talkback pushbutton is pressed and held, the audio signal associated with the Dante talkback output channel will become active until the pushbutton is released. If the talkback pushbutton is momentarily “tapped,” the audio signal on the Dante talkback output channel will change state. Upon Model 204 power up, the audio signal on the Dante talkback output channel will be in its muted state.

Remote Control Inputs

The Model 204 allows two switches or contact closures to be connected to the remote control inputs. For units with serial numbers 00501 and later, Remote Control Input 1 can also be configured to provide a tally output function that will follow the status of the main output function. Whether or not the remote control inputs are utilized will depend on the selected application. Even if connections are made to either or both of the remote control inputs how they specifically function will depend on the configuration settings.

The configuration selections are performed using STcontroller with the default setting for both remote control inputs being off. The remote control inputs can be individually configured to duplicate the action of one of the pushbutton switches with choices of main and talkback. When a remote control input is enabled it will cause an action identical to that caused by pressing or tapping the related pushbutton switch. For example, if Remote Control Input 1 is assigned to the main pushbutton function and that pushbutton is configured for latching mode, Remote Control Input 1 will also function in a latching manner. For units with serial numbers 00501 and later, if configured for main out tally the physical connection for Remote Control Input 1 will instead provide a current-limited source of 3.3 volts DC output whenever the main output function is active. This can be used to light an LED or control the input on another device.

System Operating Mode

The system operating mode configuration is used to select the overall operating mode of the Model 204. Specifically, the system operating mode determines how the main function will operate vis-à-vis the talkback function. In addition, the system operating mode will also determine if the level of the headphone

output is impacted by pushbutton activity. Understanding how the three system operating modes impact overall system operation will ensure correct operation and maximum usability.

- **On-Air:** When the system operating mode has been selected to *On-Air*, the main button will be forced to be inactive whenever the talkback function is active. The on-air mode will be appropriate for all on-air broadcast applications where it's imperative that the audio signal on the Dante main output channel and microphone output connector be muted whenever on-air talent uses the talkback function to communicate with production personnel.
- **Production:** When set for the *Production* operating mode, the status of the main button will never be impacted by the status of the talkback function. This mode allows the Dante main output channel to be used, for example, as an additional talkback output. In this way, the Dante main and talkback output channels can be used independently, with activation of any of them not impacting any of the others. This also allows both pushbutton switches to be used simultaneously. When selected for the appropriate application, the production operating mode can prove to be very useful. But it's not appropriate for on-air use!
- **Production with Dim:** This operating mode functions exactly as the production operating mode does with one addition. The level of the headphone output is dimmed (reduced in level or attenuated) by 18 dB whenever the main or talkback functions are active. In this way, the headphone output can be connected to amplified loudspeakers without the risk of acoustical feedback. The selection of this operating mode will be clearly evident as speakers (or a connected set of headphones) will be automatically reduced in level whenever the main or talkback functions are active.

Headphone Output

The three rotary potentiometers (pots), located on the Model 204's front panel, allow level adjustment of the Dante receiver (input) channels and, if enabled, the sidetone (local microphone) audio signal as they are sent to the 2-channel headphone output. How the potentiometers function will depend on the selected audio sources and routing configuration. Refer to the Configuration section for details. Five modes are available and determine the overall performance. If headphone mode 1, 2, or 3 is selected, the potentiometer on the right side, pot C, will adjust the side-tone level. The sidetone mode configuration determines exactly how the sidetone function will operate. The gain range configuration allows the overall output level to be selected. The minimum level configuration will determine what occurs when the potentiometers are in their fully counterclockwise position and, in one circumstance, its fully clockwise position. When pot C is configured for sidetone operation, it will always cause the sidetone audio to mute if it is set to its fully counterclockwise position

Users should find the headphone audio quality to be excellent, with high maximum output level and low distortion. Analog audio signals do not pass directly through the potentiometers. The position of each potentiometer is recognized by the Model 204's processor which then adjusts the appropriate signal level within the digital domain. The potentiometers are "push-in/push-out" type which allow their associated knobs to be in their "out" position when adjustment is desired and their "in" position when protection from an unwanted change is beneficial.

Technical Notes

IP Address Assignment

By default the Model 204's Ethernet interface will attempt to automatically obtain an IP address and associated settings using DHCP (Dynamic Host Configuration Protocol). If a DHCP server is not detected an IP address will automatically be assigned using the link-local protocol. This protocol is known in the Microsoft® world as Automatic Private IP Addressing (APIPA). It is also sometimes referred to as auto-IP (PIPPA). Link-local will randomly assign a unique IP address in the IPv4 range of 169.254.0.1 to 169.254.255.254. In this way, multiple Dante-enabled devices can be connected together and automatically function, whether or not a DHCP server is active on the LAN. Even two Dante-enabled devices that are directly interconnected using an RJ45 patch cord will, in many cases, correctly acquire IP addresses and be able to communicate with each other.

An exception does arise when trying to directly interconnect two Dante-enabled devices that use Ultimo integrated circuits to implement Dante. The Model 204 uses Ultimo and, as such, a direct one-to-one interconnection to another Ultimo-based product is not supported. An Ethernet switch linking the two units is required to successfully interconnect two Ultimo-based devices. The technical reason that a switch is required relates to the need for a slight latency (delay) in the data flow; an Ethernet switch will provide this.

Using the Dante Controller software application the Model 204's IP address and related network parameters can be set for a fixed (static) configuration. While this is a more involved process than simply letting DHCP or link-local "do their thing," if fixed addressing is necessary then this capability is available. In this case, it's highly recommended that every unit be physically marked, e.g., directly using a permanent marker or "console tape," with its specific static IP address. If knowledge of a Model 204's IP address has been misplaced there is no reset button or other method to easily restore the unit to a default IP setting.

In the unfortunate event that a specific Model 204's IP address is "lost," the Address Resolution Protocol (ARP) networking command can be used to "probe" devices on a network for this information. For example, in Windows OS the **arp -a** command can be used to display a list of LAN information that includes MAC addresses and corresponding IP addresses. The simplest means of identifying an unknown IP address is to create a "mini" LAN with a small PoE-enabled Ethernet switch connecting a personal computer to the Model 204. Then by using the appropriate ARP command the required "clues" can be obtained.

Optimizing Network Performance

For best Dante audio-over-Ethernet performance a network that supports VoIP QoS (voice-over-internet-protocol quality of service) capability is recommended. This can typically be implemented on virtually all contemporary managed Ethernet switches. There are even specialized switches that are optimized for entertainment-associated applications. Refer to the Audinate website (audinate.com) for details on optimizing networks for Dante applications.

Application Firmware Version Display

There are two ways in which the version number of the Model 204's application firmware (embedded software) can be identified. One requires only the Model 204 unit and involves a button-press sequence performed upon power up. The other method utilizes the Model 204 and the STcontroller software application. Either method may prove to be useful when working with factory personnel on application support and troubleshooting.

As part of the Model 204's power-up sequence, the unit's application firmware can be directly displayed. Before connecting the PoE-enabled Ethernet cable, press and hold the talkback button. Then connect the Ethernet cable. Upon application of PoE power, the Model 204 will not go through its normal power-up sequence, but instead will display the firmware version. The green LED associated with the main button will "flash" to display the major version number. The red LED associated with the talkback button will then "flash" to display the minor version number. The LEDs will then remain off until the talkback button is released. Once the talkback button is released, normal operation will then take place. As an example of what would be a typical firmware display, if the main button's LED "flashes" green twice followed by the talkback button's LED "flashing" red two times, it would indicate that application firmware version 2.2 is present in the Model 204.

A selection in the STcontroller software application allows the Model 204's application firmware version to be identified. Connect the Model 204 unit to the network and let it connect and start to function. Then, after starting STcontroller, review the list of identified devices and select the specific Model 204 from which you want to determine its application firmware version. Then select **Version** under the **Device** tab. A page will then display that will provide lots of useful information. This includes the application firmware version and well as details on the Dante interface firmware.

Application Firmware Update Procedure

It's possible that updated versions of the application firmware (embedded software) that is utilized by the Model 204's processor (microcontroller or MCU) integrated circuit will be released to add features or correct issues. Refer to the Studio Technologies' website for the latest application firmware file. The unit has the ability to load a revised file into the MCU's non-volatile memory by way of a USB interface. The Model 204 implements a USB host function that directly supports connection of a USB flash drive. The Model 204's MCU updates its firmware using a file named **m204.bin**.

The update process begins by preparing a USB flash drive. The flash drive doesn't have to be empty (blank) but must be in the personal-computer-standard FAT32 format. Save the new firmware file in the root directory with a name of **m204.bin**. Be certain to use the eject command to ensure that the file is correctly stored on the USB flash drive. Studio Technologies will supply the application firmware file inside a .zip archive file. While the firmware file inside of the zip file will adhere to the naming convention required by the Model 204, the name of the zip file itself will include the file's version number. For example, a file named **m204v2r2MCU.zip** would indicate that version 2.2 of the application firmware (**m204.bin**) is contained within this zip file.

Once the USB flash drive is inserted into the USB interface, located on the main circuit board under the cover, the unit must be powered off and again powered on. At this point the file will automatically load. The precise steps required will be highlighted in the next paragraphs.

To install an application firmware file follow these steps:

1. Disconnect power from the Model 204. This will entail removing the Ethernet connection that is providing PoE power.
2. Remove the cover from the Model 204. Use a #1 Philips-head screw driver to remove six machine screws, two on the top edge of the back panel, one on each side of the unit, and two on the front edge of the bottom surface. Be certain to save the screws so that re-assembly will be fast and painless.

Then carefully slide the cover forward, rotating it forward 180 degrees once it has cleared away from the three level potentiometers. Be very careful not to kink or damage the small ribbon interconnecting cable.

3. Locate the USB connector on the main circuit board. It's near the front of the unit, directly between the channel 1 and channel 2 level potentiometers. Insert the prepared USB flash drive into the connector.
4. Apply power to the Model 204 by connecting to a Power over Ethernet (PoE) Ethernet source.
5. After a few seconds the Model 204 will run a "boot loader" program that will automatically load the new application firmware file (**m204.bin**). During this time period an LED, located adjacent to the USB connector, will slowly flash green. Once the loading process is over, taking approximately 10 seconds, the Model 204 will restart using the newly loaded application firmware.
6. At this time the Model 204 is functioning with the newly loaded application firmware and the USB flash drive can be removed. But to be conservative, remove PoE power first and then remove the USB flash drive.
7. Confirm that the desired firmware version has been correctly loaded. This can be done by pressing and holding the talkback button, applying power to the Model 204, and then "reading" the application firmware version number by first observing the main button's green LED and then observing the talkback button's red LED. Alternately, the STcontroller software application can be used to identify the application firmware version number. Whatever method you use, ensure that the desired version is present.
8. Once the update process has been completed reverse the steps and re-attached the cover using the six machine screws.

Note that if a connected USB flash drive doesn't have the correct file (**m204.bin**) in its root folder no harm will occur if power is applied to the Model 204. Upon power up, the main button's LED will flash on and off rapidly for a few seconds to indicate this condition and then normal operation using the unit's existing application firmware will begin.

Ultimo Firmware Update

The Model 204 implements Dante connectivity using the 4-input/4-output Ultimo integrated circuit from Audinate. The Dante Controller software application can be used to determine the version of the firmware (embedded software) that resides in the Ultimo "chip." The STcontroller software application can also be used to identify the Dante firmware version. (Use the **Version** selection under the **Device** tab.) The Dante Firmware Update Manager (FUM) application program has traditionally been used to update the Ultimo firmware. Recent versions of the Dante Controller software application also include an automated method of updating Ultimo firmware. Both applications are available, free of charge, on the Audinate website (audinate.com).

Restoring Factory Defaults

A command in the STcontroller software application allows the Model 204's defaults to be reset to the factory values. From STcontroller select the Model 204 for which you want to restore its defaults. Select the **Device** tab and then select the **Factory Defaults** feature. Then click on the **OK** box. The values shown on the screen should reflect the default values. Refer to Appendix B for a list of the Model 204's factory default values.

Specifications

Power Source:

Power over Ethernet (PoE): class 2 (low power, ≤6.49 watts) per IEEE[®] 802.3af

Network Audio Technology:

Type: Dante audio-over-Ethernet

AES67-2018 Support: yes

Dante Domain Manager (DDM) Support: yes

Bit Depth: up to 24

Sample Rate: 44.1 and 48 kHz

Number of Transmitter (Output) Channels: 2

Number of Receiver (Input) Channels: 4

Dante Audio Flows: 4; 2 transmitter, 2 receiver

Network Interface:

Type: 100BASE-TX, twisted-pair Ethernet, Power over Ethernet (PoE) supported

Data Rate: 100 Mb/s (10 Mb/s and 1000 Mb/s GigE Ethernet not supported)

Microphone Input:

Compatibility: dynamic or phantom-powered microphones

Type: balanced, capacitive coupled

Impedance: 3.1 k ohms, nominal

Gain: 35, 43, 52, 59 dB, selectable

Frequency Response: 25 Hz to 20 kHz, -3 dB

Distortion (THD+N): <0.018%, measured at 35 dB of gain

Dynamic Range: 98 dB, A-weighted

Phantom Power: P48 per IEC 61938 standard, on/off selectable with status LED

Compressor:

Application: applies to Dante main and talkback transmitter (output) channels

Threshold: 1 dB above nominal level (-19 dBFS)

Slope: 2:1

Status LED: compressor active

Microphone Output:

Type: passive via two 200 ohm resistors from microphone input (will pass phantom power in either direction)

Muting: solid-state relay contacts, 60 dB attenuation @ 1 kHz

Headphone Output:

Type: 2-channel (stereo)

Compatibility: intended for connection to stereo (dual-channel) or monaural (single-channel) headphones, headsets, or earpieces with nominal impedance of 50 ohms or greater

Maximum Output Voltage: 3.0 Vrms, 1 kHz, 150 ohm load

Frequency Response: 20 Hz to 20 kHz, +0/-1 dB

Distortion (THD+N): <0.008%

Dynamic Range: >102 dB

Remote Control Inputs: 2

Function: configurable, can mimic the action of the main and talkback button functions

Type: active low, 1 mA maximum, input pulled up to 3.3 volts DC via 3.4 k (3400) ohm resistors

Limitation: Remote Control Input 1 shares hardware pin with Main Out Tally (only one function can be configured to be active at a time)

Main Out Tally (serial numbers 00501 and later):

Functions: follows the status of the main output

Type: active high, 3.3 volts DC in series with 142 ohm resistor (23 mA maximum)

Limitation: Main Out Tally shares hardware pin with Remote Control Input 1 (only one function can be configured to be active at a time)

Connectors:

Microphone Input: 3-pin female XLR

Microphone Output: 3-pin male XLR

Headphone Output: 3-conductor ¼-inch jack

Remote Control Inputs: 3-conductor 3.5 mm jack

Ethernet: Neutrik etherCON RJ45

USB: type A receptacle (located inside Model 204's enclosure and used only for updating firmware)

Configuration: uses Studio Technologies' STcontroller personal computer application

Dimensions (Overall):

4.3 inches wide (10.9 cm)

2.1 inches high (5.4 cm)

5.1 inches deep (13.0 cm)

Deployment: intended for tabletop applications

Weight: 1.2 pounds (0.55 kg)

Specifications and information contained in this User Guide subject to change without notice.

Appendix A – Model 204 Block Diagram

The following block diagram shows a simplified version of the Model 204's microphone input and microphone output circuitry.

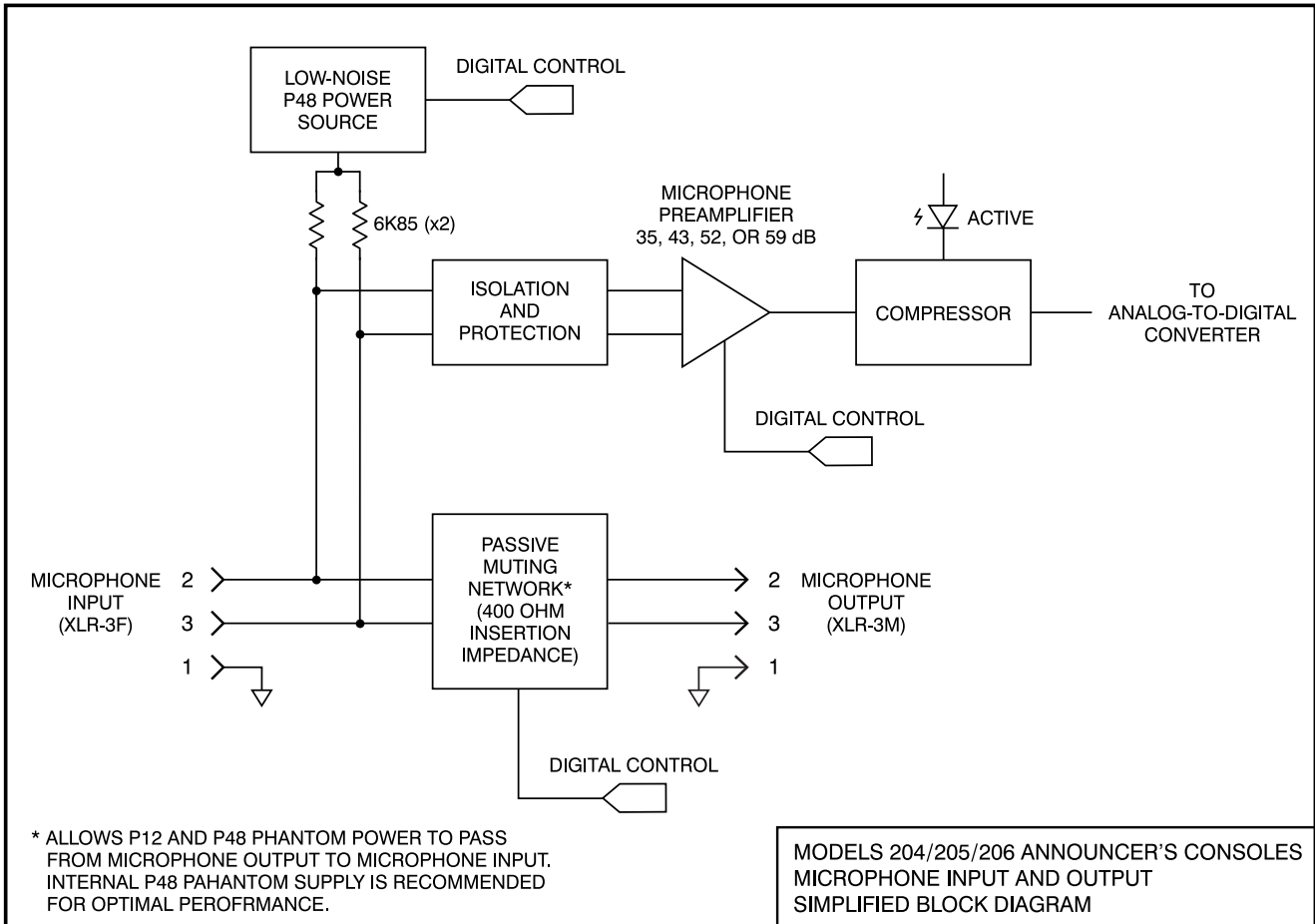

Appendix B – Model 204 STcontroller Default Configuration Values

Microphone Input – P48 Phantom: Off

Microphone Input – Gain: 35 dB

Headphone Output – Audio Sources and Routing: Mode 1

Headphone Output – Sidetone: Main and Talkback Buttons

Headphone Output – Gain Range: Low

Headphone Output – Minimum Level: –40 dB

Button Operation – Main: Push to Mute

Button Operation – Talkback: Push to Talk

System – Operating Mode: On-Air

System – Remote Control Input 1: Off

System – Remote Control Input 2: Off

System – Button Backlight Mode: Standard – High