



Model 206 Announcer's Console Featuring Dante® Technology

Key Features

- Dante audio-over-Ethernet technology
- Digital audio and direct-microphone outputs
- One main and three talkback output channels
- Highly-flexible 2-channel headphone output
- Compact unit supports one on-air location
- Excellent audio quality
- Uses STcontroller for configuration
- Power-over-Ethernet (PoE) powered

Introduction

The Model 206 Announcer's Console offers a unique combination of analog and digital audio resources for use in broadcast sports, eSports, live event, entertainment, and streaming broadcast applications. The unit is housed in a compact, rugged steel enclosure that's intended for tabletop use. Calling the Model 206 "cute" or "cool" would be accurate; its nicely proportioned but diminutive size makes it ideal for use in space-constrained locations. The Model 206 supports Dante audio-over-Ethernet digital media technology with AES67 compatibility for integration into contemporary applications. The unit is extremely simple to deploy, is "pro" quality throughout, and provides an intuitive user experience. The Model 206's audio quality is excellent, with low distortion, low noise, and ample headroom. Careful circuit design and rugged components ensure long, reliable operation.

The Model 206 integrates directly into both Dante audio-over-Ethernet and standard analog audio environments. With just a Power-over-Ethernet (PoE) connection, a microphone, and a pair of headphones or an earpiece, a complete broadcast on-air position can be created. And by using the Model 206's microphone output a direct connection to an analog microphone-level input on an associated camera, remote I/O interface, or audio console can be supported. Two remote control inputs allow external switches or contact closures to activate the main and talkback button functions. One of the inputs can also be configured to provide a low-voltage DC "tally" output that follows the state of the main output.

Model 206 operating features are configured using the STcontroller software application. An extensive set of parameters allows the unit's functions to be tailored to meet the needs of many applications. STcontroller is a fast and simple means of confirming and revising the unit's operating parameters.



Applications

The Model 206 on its own can provide an "all-Dante" solution for one on-air talent location. A wide range of applications can be supported, including sports and entertainment TV and radio events, streaming broadcasts, corporate and government AV installations, and post-production facilities. The unit's small size makes it ideal for live-sports applications, such as basketball, where physical space for personnel is very limited. Four Dante receiver (input) audio channels supply the user with their talent cue (IFB) signals. Should the cue signal be "mix-minus" an integrated sidetone function can provide the user with a microphone confidence signal. Four Dante transmitter (output) audio channels, one designated as main and three as talkback, are routed via an associated local-area network (LAN) to inputs on Dante-compatible devices. Four pushbutton switches, main and three talkback, provide the user with direct control over audio routing. The audio switching is performed in the digital domain and is virtually "click-free."

By providing the main audio signal in two forms, Dante digital audio and analog microphone level, the Model 206 makes integration into a wide range of on-air environments easy to accomplish. And with three talkback audio channels available as Dante transmitter (output) channels routing to inputs on a variety of devices, such as matrix intercom systems, audio consoles, and monitor loudspeaker systems, is simple and flexible.

Some applications may benefit from not utilizing the Model 206's Dante main output channel. This typically won't be an issue of inadequate audio quality but rather a need to match work-flow requirements. For example, for lip-sync or transmission purposes it may be optimal to have the on-air audio transported as an embedded signal along with the associated camera video. Alternately, all on-air audio sources may need to connect to inputs on an audio console or console-related I/O unit. Supporting these scenarios is not a problem as the Model 206 supplies a microphone output connection that's specifically intended for this purpose. Simply connect the unit's microphone output connection to the desired analog input, such as the mic/line input on an ENG-style camera—that's it!

The circuitry associated with the Model 206's analog microphone output is very simple, essentially a passive path that routes a signal connected to the microphone input connector directly to the microphone output connector. A solid-state circuit, in series with the mic in-to-mic out path, allows muting of the signal on the microphone output connector whenever the Dante main output channel is muted. Having both the Dante main output and the microphone outputs work in tandem can be a valuable resource, allowing one to serve as the primary on-air signal source while the other serves as the backup.

Setup and Operation

Set up, configuration, and operation of the Model 206 is simple. An etherCON® RJ45 jack is used to interconnect with a standard twisted-pair Ethernet port associated with a PoE-enabled network switch. This connection provides both power and bi-directional digital audio. A broadcast headset or handheld ("stick") microphone can be directly connected to the unit's 3-pin XLR mic input connector. The input is compatible with dynamic or condenser microphones. The integrated P48 phantom power source provides support for a wide range of condenser microphones. A 3-pin XLR microphone output connector provides a "direct mic out" function for integration with microphone inputs on related devices. Stereo headphones, the headphone connections from a stereo or monaural headset, or even a monaural earpiece can be connected to the phones output jack.

External switches or contact closures can be connected to the Model 206's remote control inputs to allow activation of the main and talkback button functions. For units with serial numbers 00501 and later, a low-voltage/low-current DC output can also be implemented providing a Main Out Tally function.

The STcontroller software application is used to configure the wide range of Model 206 operating parameters. This allows the unit's performance to be optimized to meet the needs of specific applications.

The user is presented with four pushbutton switches and three push-in/push-out rotary level potentiometers. This makes it easy to control the status of the main and talkback outputs as well as adjusting the signals that are sent to the headphone channels.

Ethernet Data and PoE

The Model 206 connects to a local area network (LAN) by way of a standard 100 Mb/s twisted-pair Ethernet interface. The physical 100BASE-TX interconnection is made by way of a Neutrik® etherCON RJ45 connector. While compatible with standard RJ45 plugs, etherCON allows a ruggedized and locking interconnection for harsh or high-reliability environments.

The Model 206's operating power is provided by way of the Ethernet interface using the 802.3af Power-over-Ethernet (PoE) standard. This allows fast and efficient interconnection with the associated data network. To support PoE power management, the Model 206's PoE interface enumerates (reports) to the power sourcing equipment (PSE) that it's a class 2 (low power) device.

Dante Audio-over-Ethernet

Audio data is sent to and received from the Model 206 using the Dante audio-over-Ethernet media networking technology. As a Dante-compliant device, the Model 206's four Dante transmitter (output) channels and four Dante receiver (input) channels can be assigned (routed or "subscribed") to other devices using the Dante Controller software application. The Dante transmitter (output) and receiver (input) channels are limited to supporting four Dante flows, two in each direction. The digital audio's bit depth is up to 24 with a sampling rate of 44.1 or 48 kHz. Two bi-color LEDs provide an indication of the Dante connection status. An additional LED displays the status of the associated Ethernet connection.

The Model 206 is compatible with the AES67 interoperability standard. In this mode, the two transmitter (output) channels will function in multicast; unicast is not supported. In addition, the unit is compatible with the Dante Domain Manager™ (DDM) software application.

Audio Quality

The Model 206's audio performance is completely "pro." A low-noise, wide dynamic-range microphone preamplifier and associated voltage-controlled-amplifier (VCA) dynamics controller (compressor) ensures that mic input audio quality is preserved while minimizing the chance of signal overload. The output of the microphone preamp and compressor is routed to an analog-to-digital conversion (ADC) section that supports

sampling rates of 44.1 and 48 kHz with a bit depth of up to 24. The audio signal, now in the digital domain, routes through a 32-bit microprocessor and on to the Dante interface section where it is packetized and prepared for transport over Ethernet.

Audio signals arrive via the four Dante receiver (input) channels and pass into the Model 206's microprocessor. The supported sampling rates are 44.1 and 48 kHz with a bit depth of up to 24. Channel routing, headphone level control, and sidetone creation are performed within the digital domain. This provides flexibility, allows precise control, and keeps the three level potentiometers from having to directly handle analog audio signals. The audio channels destined for the phones outputs are sent to a high-performance digital-to-analog converter and then on to robust driver circuitry. High signal levels can be provided to a variety of headsets, headphones, and earpieces.

Configuration Flexibility

The Model 206 can be configured to meet the needs of specific applications and user preferences. All configuration choices are performed using the STcontroller software application. There are no mechanical switch settings or button-press sequences required to configure how the unit functions. Selectable parameters include microphone preamplifier gain, P48 phantom power on/off, button operation, remote control inputs (including tally output), headphone output mode, sidetone operation, and overall unit operation. The gain of the microphone preamplifier can be selected from among four choices. This allows the Model 206 to match the output sensitivity of a range of handheld and headset-associated microphones. A low-noise source of P48 phantom power can be enabled if required to support condenser (capacitor) microphones.

The main and talkback pushbutton switches can be individually configured. The main button can be selected to operate from among five modes while the talkback button can be selected from among three. These choices allow the Model 206's operation to be tailored to meet the specific needs of many applications. As an example, for on-air sports applications the main button would typically be configured to provide a push to mute (cough) function. The microphone signal on the Dante main output channel and the microphone output connector would remain active unless the talent needs to momentarily disable it. The talkback buttons would most likely be set to the push to talk mode as its use would be intermittent.

Red and green LEDs are associated with the main and talkback pushbutton switches. A configuration choice allows selection of the manner in which the LEDs will light under various operating conditions. This capability was specifically provided to assist users who have trouble observing the differences between colors, typically issues with red and green. "Color blindness" is not infrequently found in men and can make effective use of some electronic equipment difficult. In addition, the Model 206's

ability to control the colors presented by the pushbuttons can be useful for international applications. Local preferences will often determine which color is associated with a function being "on" and which color is associated with a function being "off."

The Model 206 provides two remote control inputs. Configuration choices allow each input to be assigned to work in parallel with the main or one of the talkback pushbutton switches. In this way, activation of a remote control input will emulate a user pressing its associated pushbutton switch. For units with serial numbers 00501 and later, Remote Control Input 1 can also be configured to provide a Main Out Tally function.

The audio sources and the way in which they are assigned to the headphone output channels can be configured from among five choices. These unique choices allow almost any required headphone monitoring situation to be implemented. Whether for use in on-air sports, an awards show broadcast, or as a production support tool, the Model 206 should be able to achieve the desired configuration.

Following the mode number is an abbreviated description of what signal or signals are assigned to the three potentiometers (pots) and on to the two headphone output channels. The potentiometers are labeled A, B, and C. The format would equate to Mode x – pot A/pot B/pot C where x equals the mode number.

- Mode 1 – Ch1L/Ch2R/SidetoneLR: Provided for broadcast applications where two monaural channels of talent cueing audio ("IFB") need to be independently sent to the left and right headphone output channels. It would be common for program audio with director interrupt to enter the Model 206 by way of Dante receiver (input) channel 1 and be sent to the left headphone output. Program-only audio, entering the unit by way of Dante receiver (input) channel 2, would be sent to the right headphone output. Pots A and B are used to adjust the level of those signals. Pot C is used for the sidetone function where microphone audio is sent to both the left and right channels of the headphone output.
- Mode 2 – Ch1LCh2R/BalanceLR/SidetoneLR: Intended for applications where a stereo signal enters the Model 206 by way of Dante receiver (input) channels 1 and 2 and is routed to the left and right channels of the headphone output. In this mode pot A controls the overall level of this stereo signal and pot B controls its left/right level balance. Pot C is used by the sidetone function.
- Mode 3 – Ch1LCh2R/Ch3LCh4R/SidetoneLR: Allows two stereo signals to be routed as stereo pairs to the two headphone output channels. In this mode pot A adjusts the level of the stereo pair entering the unit by way of Dante receiver (input) channels 1 and 2 while pot B adjusts the level of the stereo pair entering on Dante receiver (input) channels 3 and 4. Pot C is used by the sidetone function.

- Mode 4 – Ch1L/Ch2R/Ch3LCh4R: Allows two monaural input signals to be independently routed to the left and right headphone output channels. These audio signals would enter the Model 206 by way of Dante receiver (input) channels 1 and 2. Pots A and B are used to control the levels of the signals as they are sent to the left and right headphone output channels. A stereo input signal, entering the unit by way of Dante receiver (input) channels 3 and 4, are routed to the left and right headphone outputs. This stereo pair has its level controlled by pot C.
- Mode 5 – Ch1LR/Ch2LR/Ch3LCh4R: Allows two monaural input audio channels to be sent to both the left and right headphone output channels. Dante receiver (input) channels 1 and 2 are used to bring these audio signals into the Model 206. Pots A and B are used to control the level of the signals as they are sent to the headphone output channels. Pot C is used to control the level of a stereo input signal as it is routed to the left and right channels of the headphone output. This stereo pair enters the unit by way of Dante receiver (input) channels 3 and 4.

The integrated sidetone function can be configured to operate from among four choices. This allows audio associated with the microphone input and microphone preamplifier to be returned to the headphone output. This is important as different applications may provide a “full mix” or a “mix-minus” talent cue signal. If a full mix cue signal is provided then sidetone audio will not be needed and the function can be disabled. In the case where a mix-minus signal is present, providing the user with sidetone at the appropriate time(s) can be an important means of confirming the signal that’s coming from the connected microphone.

The headphone gain range configuration helps to provide an optimized audio level to Model 206 users. The appropriate setting will depend on the specific audio sources provided to the unit as well as user preference.

Three system modes select the overall way in which the Model 206 functions. The on-air mode is optimized for applications where users will be on-air talent that must maintain strict separation between on-air and production audio channels. Other applications will benefit from the two available production modes.

Future Capabilities and Firmware Updating

The Model 206 was designed so that its capabilities and performance can be enhanced in the future. A USB connector, located on the unit’s main circuit board (underneath the unit’s cover), allows the application firmware (embedded software) to be updated using a USB flash drive.

The Model 206 uses the Audinate Ultimo™ integrated circuit to implement the Dante interface. The firmware in this integrated circuit can be updated via the Ethernet connection, helping to ensure that its capabilities remain up to date.

Model 206 Specifications

Power Source:

Power-over-Ethernet (PoE): class 2 (low power, ≤6.49 watts) per IEEE® 802.3af

Network Audio Technology:

Type: Dante audio-over-Ethernet
AES67-2018 Support: yes
Dante Domain Manager (DDM) Support: yes
Bit Depth: up to 24
Sample Rate: 44.1 and 48 kHz
Number of Transmitter (Output) Channels: 4
Number of Receiver (Input) Channels: 4
Dante Audio Flows: 4; 2 transmitter, 2 receiver

Network Interface:

Type: 100BASE-TX, twisted-pair Ethernet, Power-over-Ethernet (PoE) supported
Data Rate: 100 Mb/s (10 Mb/s and 1000 Mb/s GigE Ethernet not supported)

Microphone Input:

Compatibility: dynamic or phantom-powered microphones
Type: balanced, capacitive coupled
Impedance: 3.1 k ohms, nominal
Gain: 35, 43, 52, 59 dB, selectable
Frequency Response: 25 Hz to 20 kHz, -3 dB
Distortion (THD+N): <0.018%, measured at 35 dB of gain
Dynamic Range: 98 dB, A-weighted
Phantom Power: P48 per IEC 61938 standard, on/off selectable with status LED

Compressor:

Application: applies to Dante main and talkback transmitter (output) channels
Threshold: 1 dB above nominal level (-19 dBFS)
Slope: 2:1
Status LED: compressor active

Microphone Output:

Type: passive via two 200 ohm resistors from microphone input (will pass phantom power in either direction)
Muting: solid-state relay contacts, 60 dB attenuation @ 1 kHz

Headphone Output:

Type: 2-channel (stereo)
Compatibility: intended for connection to stereo (dual-channel) or monaural (single-channel) headphones, headsets, or earpieces with nominal impedance of 50 ohms or greater
Maximum Output Voltage: 3.0 Vrms, 1 kHz, 150 ohm load
Frequency Response: 20 Hz to 20 kHz, +0/-1 dB
Distortion (THD+N): <0.008%
Dynamic Range: >102 dB

Remote Control Inputs: 2

Function: configurable, can mimic the action of the main and talkback button functions
Type: active low, 1 mA maximum, input pulled up to 3.3 volts DC via 3.4 k (4300) ohm resistors
Limitation: Remote Control Input 1 shares hardware pin with Main Out Tally (only one function can be configured to be active at a time)

Main Out Tally (serial numbers 00501 and later):

Functions: follows the status of the main output
Type: active high, 3.3 volts DC in series with 142 ohm resistor (23 mA maximum)
Limitation: Main Out Tally shares hardware pin with Remote Control Input 1 (only one function can be configured to be active at a time)

Connectors:

Microphone Input: 3-pin female XLR
Microphone Output: 3-pin male XLR
Headphone Output: 3-conductor ¼-inch jack
Remote Control Inputs: 3-conductor 3.5 mm jack
Ethernet: Neutrik etherCON RJ45
USB: type A receptacle (located inside Model 206's enclosure and used only for updating firmware)

Configuration: uses Studio Technologies' STcontroller personal computer application

Dimensions (Overall):

4.3 inches wide (10.9 cm)
2.1 inches high (5.4 cm)
5.1 inches deep (13.0 cm)

Deployment: intended for tabletop applications

Weight: 1.2 pounds (0.55 kg)

Specifications subject to change without notice.

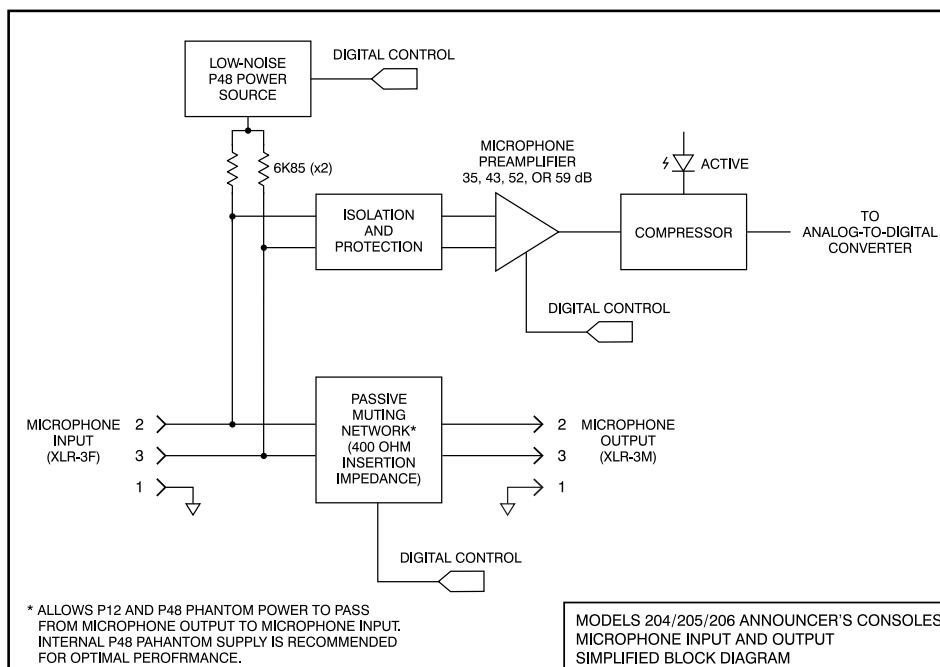

Studio Technologies, Inc.

Skokie, Illinois USA

© by Studio Technologies, Inc., April 2026

studio-tech.com