

Studio Tools

Model 85 AES/EBU Digital Audio Distribution Amplifier

User Guide

Issue 4, June 2011

This User Guide is applicable for serial numbers:

Model 85 M85-00151 and later

Copyright © 2011 by Studio Technologies, Inc., all rights reserved
www.studio-tech.com

This page intentionally left blank.

Table of Contents

Introduction.....	5
What This User Guide Covers.....	5
System Overview.....	5
Installation	6
Configuration	8
Operation.....	8
Troubleshooting.....	8
Specifications	10
Block Diagram	

This page intentionally left blank.

Introduction

The Model 85 AES/EBU Digital Audio Distribution Amplifier is designed by Studio Technologies as part of its Studio Tools group of audio support products.

Designed for a wide variety of recording, production, broadcast, and duplication applications, the Model 85 has two AES/EBU inputs and eight AES/EBU outputs. All Model 85 functions meet or exceed the performance of the most expensive “high end” audio equipment.

What This User Guide Covers

This User Guide is designed to assist you when installing, configuring, and using the Model 85 AES/EBU Digital Audio Distribution Amplifier.

System Overview

The Model 85 provides two AES/EBU digital audio inputs and eight AES/EBU outputs. Each of the eight outputs provides a fully isolated reproduction of either input. Output source selection is provided by front-panel DIP switches. The Model 85 allows AES/EBU signals to be distributed to multiple inputs (receivers) without incurring data transmission errors.

A typical application would use the Model 85 to distribute the AES/EBU output of a digital audio workstation (DAW) to devices such as DAT or CD recorders, audio/video storage systems, tie lines to other facilities, etc.

Single rack space mounting, standard XLR-type connectors, and status LEDs make installation of the Model 85 a simple job. The AC mains input power is factory configured for 100, 120, or 220/240 V

operation. Components and construction standards make the Model 85 suitable for continuous operation, even for on-air broadcast applications.

AES/EBU Inputs

Each of the two inputs have transformer coupling and DC voltage blocking. An LED status indicator is associated with each input, lighting whenever digital information is present.

AES/EBU Outputs

The Model 85 contains eight independent AES/EBU output sections. The rugged output circuits feature transformer coupling. For flexibility, each of the eight outputs can individually select input A or B as its source. This allows the Model 85 to act as a single 1x8 distribution amplifier (DA), or two fully independent DAs. Example configurations include creating a dual 1x4 DA, or a combination 1x3 DA and 1x5 DA.

Technical Background

The original AES/EBU specification (AES3-1985) called for a single transmitter to drive up to three receivers. In practice this proved to make data transmission susceptible to errors as an impedance mismatch is created whenever more than one receiver is driven. The revised edition of the specification (AES3-1992) advises that a single transmitter should drive only a single receiver. The Model 85 addresses this requirement in a simple, reliable manner. Up to eight identical, but fully isolated, “copies” of the original source are created.

No Data Manipulation

The Model 85 performs minimal processing to the AES/EBU digital audio data. The signal is received, converted to a standard

logic signal, then retransmitted using rugged driver circuits. No timing “correction” is performed. No data is manipulated, added, or changed. The Model 85 assumes that your digital signals have been carefully created and simply need to be distributed to multiple inputs. In an age when everyone wants to “fix” your digital signals the Model 85 takes a “hands off” approach. With a nominal 60 nanosecond input to output delay, the outputs are essentially identical to the inputs.

Installation

In this section you will be installing the Model 85 in an equipment rack. AES/EBU input and output connections will be made

using the ten XLR-type connectors located on the back panel. AC mains power will be connected to the Model 85.

System Components

The shipping carton contains a Model 85, User Guide, and warranty card. Units destined for North America are shipped with an AC mains cord. Your dealer or distributor will provide an AC mains cord for non-North American destinations.

Mounting the Model 85

The Model 85 requires one space in a standard 19-inch (48.3 cm) equipment rack. It is desirable to locate the Model 85 to allow easy access to both the front and the back panels. The back panel contains the input and output connectors. The front

Model 85 Front Panel

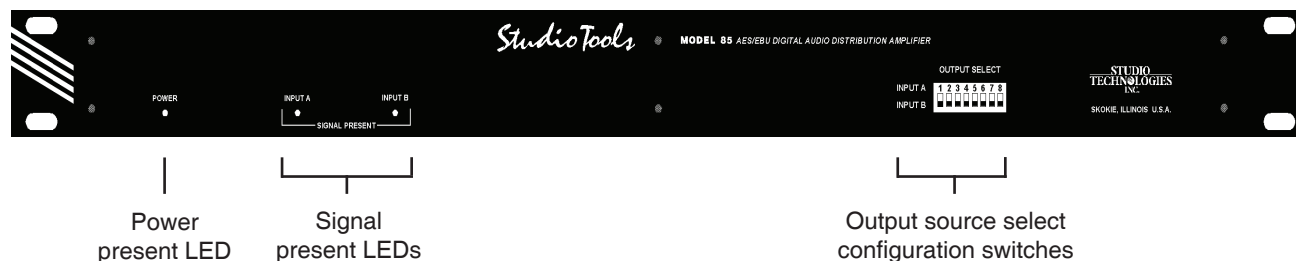

Model 85 Back Panel

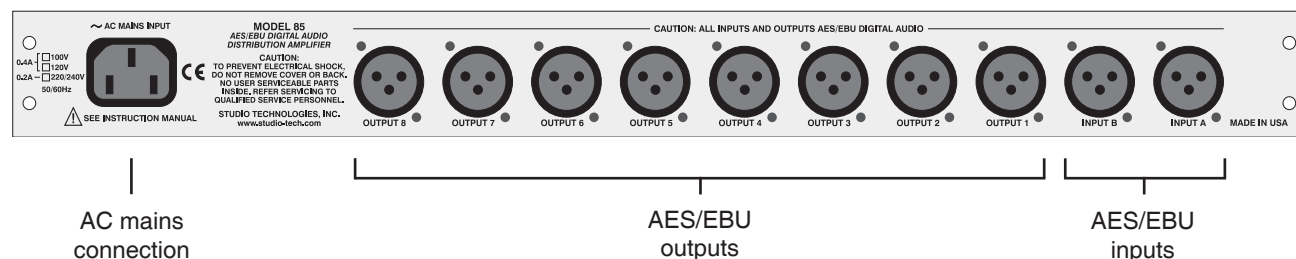

panel is used to access the output-select switches. The front panel also contains several LED indicators. The Model 85 is secured to the equipment rack using two mounting screws per side.

AES/EBU Inputs

The Model 85 provides two AES/EBU inputs. Physically the inputs are located on the back panel and use standard 3-pin XLR-type female connectors. The source signals will need to terminate on cables with XLR-type male plugs to connect with the inputs.

While it's a good idea to always maintain consistent cable polarity, the AES/EBU specification clearly states that signal polarity is not an issue. With this in mind understand that identifying one of the pins as "hot" or "high" is not really relevant. For consistency the Model 85 does maintain input-to-output polarity. A low-to-high transition on pin 2 of the input results in a low-to-high transition on an output.

For best performance you should consider AES/EBU signals to always be a balanced (differential) signal. Pins 2 and 3 of the XLR-type connectors should carry signal and pin 1 is appropriate for shield. Never strap pin 2 or pin 3 to pin 1—this might be appropriate for unbalanced analog signals but not for this fast-movin' digital cat!

Beyond containing a shield appropriate for digital signals, the exact cable choice is up to you. There is an inverse relationship between cable capacitance and maximum allowable cable length. The AES/EBU specification calls for a 100 meter maximum, but high performance cable should allow a longer run.

Part of the Model 85's flexibility is the fact that each of the eight outputs can select as its source either input A or input B. If you're using the unit strictly as a 1-input/8-output device, only a connection to input A is required. If some outputs have input A as their source, and others have input B as their source, then you'll need signals connected to both inputs.

AES/EBU Outputs

The Model 85 contains eight independent AES/EBU outputs. The signals are accessible on the back panel by means of eight 3-pin XLR-type male connectors. Your cables will need to terminate on XLR-type female connectors. The recommendations made for the inputs also apply for the outputs: maintain polarity, wire for balanced operation, and select, if appropriate, a low-capacitance cable.

AC Mains Power

The Model 85 is internally configured to operate from either 100, 120, or 220/240 V, 50/60 Hz. In most cases, units shipped to North America are factory selected for 120 V operation. Units bound for Japan are selected for 100 V, while our friends "down under" and in Europe receive units set for 220/240 V. Before connecting the Model 85 to AC mains power, check that it is configured to match the local mains voltage. Look on the back panel, adjacent to the power entry connector, for the configured voltage(s). Note that an incorrect configuration could seriously damage the unit. Should it be necessary to change the unit's operating voltage it must be performed only at the factory or by an authorized service technician.

The Model 85 uses an IEC standard connector to mate with the AC mains cord. The wire colors in the AC mains cord should conform to the internationally recognized CEE color code and must be wired accordingly:

<u>Connection</u>	<u>Wire Color</u>
Neutral (N)	Light Blue
Line (L)	Brown
Protective Earth (E)	Green/Yellow

Safety Warning: The Model 85 does not contain an AC mains disconnect switch. As such the mains cord plug serves as the disconnection device. Safety consideration requires that the plug and associated outlet be easily accessible to allow rapid disconnection of mains power should it prove necessary.

As soon as AC mains power is connected, the Model 85's power present LED will light. If a digital signal is active on an input its associated signal present LED will light. The unit is now ready for years of trusty service!

Configuration

Output Source Selection

Each of the eight AES/EBU outputs is individually configurable to have input A or input B as its source. Eight DIP-type switches, located on the right side of the front panel, are used to select the source for each output. The legend on the switches corresponds to the output channel numbers. A switch that is set to the up position

sets its associated output channel for a source of input A. A switch in the down position selects input B. A small flat-blade screwdriver may be of assistance when setting the switches.

Operation

Now that you've installed and configured the system, you're ready to go. You should find operation very easy; there is almost nothing to do on a day-to-day basis. For peace of mind, the signal present LEDs will give you a visual indication whenever signals are present on the Model 85's inputs. Note that the signal present LEDs are not intended to provide an indication that valid AES/EBU signals are present. They are provided as a handy macro method of determining if signals are active on the inputs.

Each of the eight outputs is fully independent. You can patch, reconnect, or even short out an interconnecting cable without effecting the other outputs. Using the front-panel DIP switches you can change the output source of any or all of the outputs whenever you wish.

Troubleshooting

If you're having problems getting the Model 85 up and running, this section can help. If you haven't read the other sections of this guide, you should do so before proceeding.

If the Model 85 Doesn't Work At All

A source of AC mains power must be connected to the Model 85. Depending on the version you have purchased, 100,

120, or 220/240 Vac, 50/60 Hz is required. Confirm what mains voltage is required by observing the selection boxes to the left of the AC mains connector on the back panel. Whenever mains power is connected the power present LED should be lit. If the LED is not lit confirm that the main power source is active (“hot”) and that the connector on the cord is securely mated with the plug on the back panel.

For safety in the event of a major internal failure or the connection of incorrect AC mains voltage, the Model 85 contains a fuse inside the cabinet. The fuse will open (“blow”) if the failure of an internal component causes excessive current to be drawn from the internal power supply. The fuse will also open should 220/240 Vac be connected to a Model 85 that is configured for 100 or 120 Vac operation. The fuse is intended to be replaced only by a qualified service technician. This person will have the training to safely access the “guts” of the Model 85 and identify where a problem is located.

If Signal Doesn’t Seem to Be Present on the Outputs

Valid outputs depend on a valid input source. Ensure that the signal present LEDs are lit in response to what you consider valid input signals. Should a signal present LED not be lit confirm that the source is operating and the cabling has been correctly prepared. On the front panel, check the output source selection switches to confirm the correct settings.

Specifications

AES/EBU Inputs: 2

Type: capacitor isolated, transformer coupled

Receiver Equalization: none

Impedance: 110 ohms, nominal

Amplitude Range: 0.3 to 7 Vp-p

AES/EBU Outputs: 8

Type: transformer coupled

Impedance: 110 ohms, nominal

Level: 3.0 Vp-p, terminated, nominal

Input-Output Time Delay: 60 nSec, nominal

AES/EBU Performance Compatibility: designed for compliance with AES3-1992 (ANSI S4.40-1992), AES Recommended practice for digital audio engineering—Serial transmission format for two-channel linearly represented digital audio data

LED Indicators: 3

Function: 1 power present, 2 signal present

Fusing: 1

Type: 5 x 20 mm time lag (Littelfuse 218-series or equivalent)

Rating: 0.400 A for 100 and 120 V mains power, 0.200 A for 220/240 V mains power

Connectors:

AES/EBU: 3-pin XLR-type, female (2), male (8)

AC Mains: standard 3-blade plug, meets IEC 320 specifications

AC Mains Requirement: 100, 120, or 220/240 V, $\pm 10\%$, factory configured, 50/60 Hz, 100-120 V 0.4 A maximum, 220/240 V 0.2 A maximum

Dimensions (Overall):

19.00 inches wide (48.3 cm)

1.72 inches high (4.4 cm)

6.65 inches deep (16.9 cm)

Mounting: one space (1U) in a standard 19-inch rack

Weight: 7.0 pounds (3.2 kg)

Specifications and information contained in this User Guide subject to change without notice.

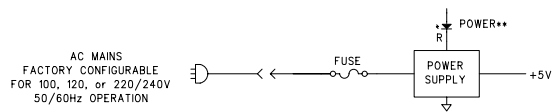
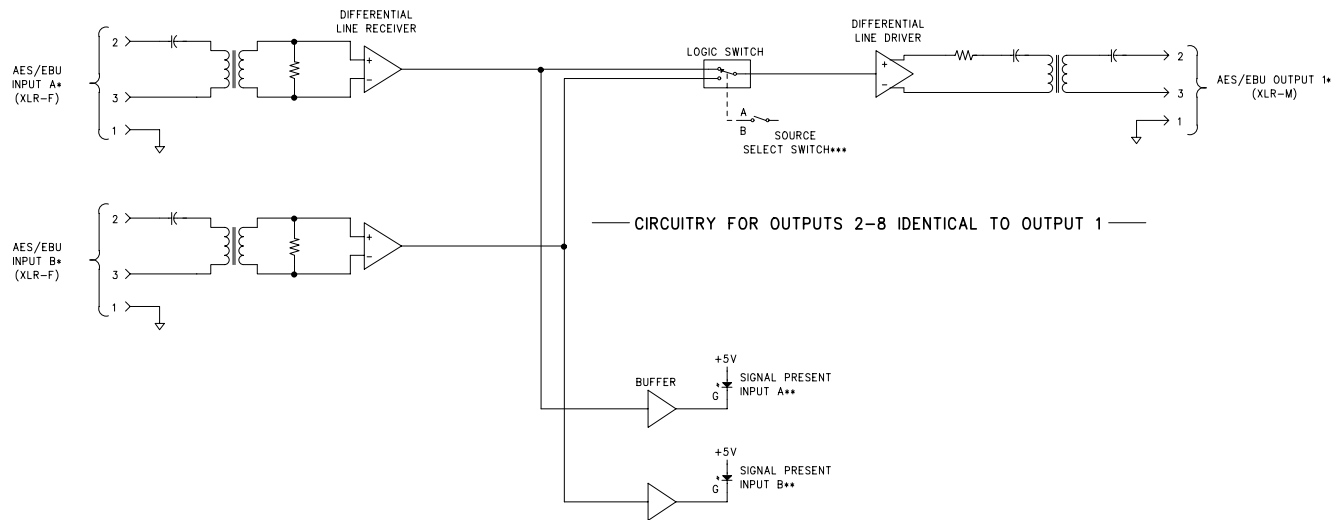

- * LOCATED ON BACK PANEL
- ** LOCATED ON FRONT PANEL
- *** DIP-TYPE SWITCH LOCATED ON FRONT PANEL

M85BD_C		
STUDIO TECHNOLOGIES, INC.		
MODEL 85 AES/EBU DIGITAL AUDIO DISTRIBUTION AMPLIFIER BLOCK DIAGRAM		
DRAWING NO.	DATE	PAGE
30476	06/01/94	01 OF 01