

# *StudioComm*

## **Model 55 Central Controller, Model 56 Control Console, and Related Components**

### **User Guide**

Issue 5, August 2005

This User Guide is applicable for serial numbers:

Model 55 M55-00280 and later

Model 56 M56-00280 and later

**© 2005 by Studio Technologies, Inc., all rights reserved**

[www.studio-tech.com](http://www.studio-tech.com)



# Table of Contents

Foreword	
Introduction.....	7
What This User Guide Covers.....	7
System Overview .....	7
System Features .....	7
Installation .....	11
Configuration .....	15
Model 56 Configuration Chart—Main Functions .....	18
Model 56 Configuration Chart— Alternate Functions .....	19
Operation.....	20
Troubleshooting.....	22
Technical Notes.....	24
Specifications .....	28
Appendix A .....	30
MIDI Messages .....	31
Block Diagrams	
Model 55 Central Controller	
Model 56 Control Console	
Model 35 Talent Amplifier	
Model 70 Interface	

This page intentionally left blank.

# Foreword

I am pleased to present the StudioComm series of products. As both president and owner of Studio Technologies, I take a very personal approach when designing products. Getting older has increased my appreciation of the more subtle things in life—be they a part of nature or the nuances contained in a well-designed piece of electronic equipment. Do the technical and operational aspects of a product work together to “feel” right? A Studio Technologies’ design is ready to go only when I am completely satisfied. My entire focus for the StudioComm series was to make a system that you’d really enjoy using, and one that would perform reliably for years. I hope you share my enthusiasm.

Many fine people worked toward making the StudioComm “happen.” Mitch Budniak (ace consulting engineer) designed many of the circuits. Jim Cunningham contributed to the analog design. Larry Leviton wrote the excellent micro-controller software. Al Lux designed the printed circuit boards. Carrie Loving designed the graphics. Fred Roeck performed the mechanical design. Joe Urbanczyk coordinated the safety testing and agency approvals.

Many thanks to Bob Tjarks, professional audio sales manager at Gand Music & Sound, Northfield, Illinois. Bob brought to my attention the need for a product to serve digital audio workstations. His product idea evolved into the StudioComm series. Additional thanks to Timothy Powell of Metro Mobile Recording, Glenview, Illinois, who provided his excellent ears when issues of sonic quality arose. His extensive field and studio experience was extremely helpful in keeping me on the audio “straight and narrow.”

Please contact me with your questions, comments, and suggestions. I can be reached by voice at (847) 676-9177, fax at (847) 982-0747, or via the Internet @ [www.studio-tech.com](http://www.studio-tech.com).

Sincerely,

Gordon K. Kapes  
President

This page intentionally left blank.

# Introduction

## What This User Guide Covers

This User Guide is designed to assist you when installing, configuring, and using the Model 55 Central Controller, Model 56 Control Console, Model 35 Talent Amplifier, and related components.

## System Overview

The Model 55 Central Controller, along with the companion Model 56 Control Console, are members of the StudioComm family of products. The Models 55 and 56 are specifically designed to work in conjunction with digital audio workstations to provide a full set of monitoring and communications functions. Features include control room monitoring, meter output, an integrated headphone system, dubbing, and communications functions that include talk to phones and slate. All StudioComm functions perform to a level that rivals even the largest recording consoles. Many of the functions are user configurable, allowing unmatched flexibility.

A complete StudioComm system consists of a rack-mounted central controller, a desktop control console, and one or more portable talent amplifier units. The Model 55 Central Controller and the Model 56 Control Console work together, interconnecting using a standard 5-pin MIDI-style cable.

Circuitry in the Model 55 routes any of four stereo inputs to the control room, meter, headphone, and dub outputs, with commands provided by the Model 56 Control Console. The Model 56 Control Console's built-in microphone lets you talk to the headphone output. It also allows you to talk to the dub output, or to the dub and headphone outputs using the slate function.

The Model 35 Talent Amplifier is a portable amplifier unit capable of driving one or two pairs of high-impedance stereo headphones. A single microphone-type cable links the Model 35 with the Model 55 Central Controller. The Central Controller provides power and left and right audio over just three wires.

## System Features

### Stereo Line Inputs

The Model 55 contains four stereo line-level inputs which are compatible with both balanced and unbalanced signals. Each input is independently software configurable for a nominal input level of  $-10$  dBV or  $+4$  dBu. This allows direct connection with virtually any audio source. Each input can also be configured to operate as a mono input. In this manner, a signal connected to the left input is routed to both the left and right outputs.

### Control Room Monitoring

The control room section provides a stereo line-level output for driving a power amplifier associated with monitor loudspeakers. Four buttons are used to select the input source to be monitored. Normally, only one of the four input sources is selected for monitoring. For special applications, the system can be configured to allow two input sources to be simultaneously monitored. The control room level is adjusted using a smooth-feeling rotary potentiometer. The Dim button allows the control room level to be temporarily reduced. The Mono button allows the sum (L+R) of the selected source to be sent as the control room output.

## Meter Output

The meter output provides a stereo output that “follows” the source(s) selected for the control room. The signal is not affected by the control room level circuitry, but is “post-mono.” The meter output is intended to be connected to VU- or PPM-type meter panels that contain series current-limiting resistors or input buffer amplifiers.

## Dub Output

A stereo line-level output is provided as a dub (copy) output. Any of the four inputs can be assigned to the dub output. The slate function allows communications (voice) audio to be sent out the dub output.

## Communications Functions

The Model 56 Control Console contains an internal microphone that is used in conjunction with the two communications

functions. The talk to phones function either interrupts the phones source or adds (sums or mixes) to the phones source. The slate function interrupts the dub source and, if configured, the headphone source and connects communications audio. The audio level of each communications function is individually adjustable.

## MIDI Control

All Model 55 Central Controller functions are controlled using system-exclusive MIDI messages. The Model 56 Control Console “speaks” this language, and in most applications a Model 56 will be utilized. In special applications the Model 55 Central Controller can be connected directly to a MIDI bus, allowing the creation of a fully automated recording or audio routing system. For more information on MIDI support, refer to Appendix A.

## Model 55 Front Panel

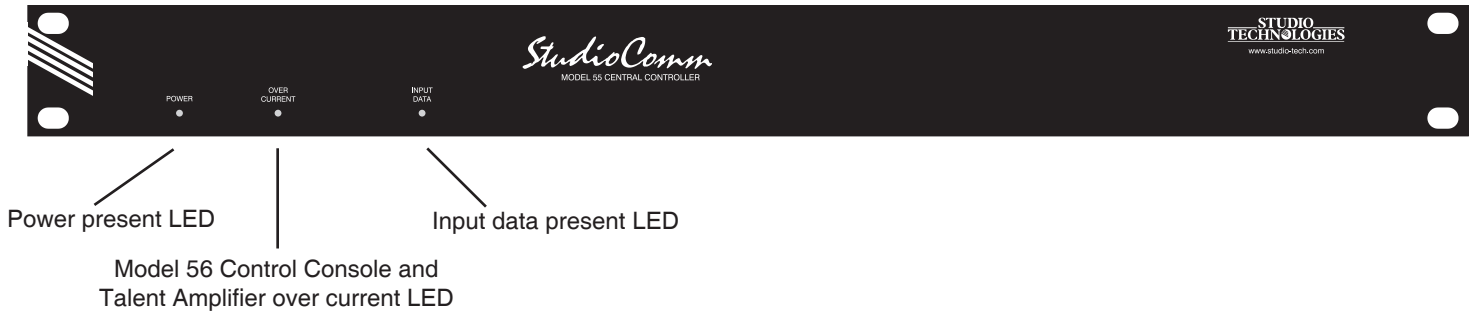

## Model 55 Back Panel

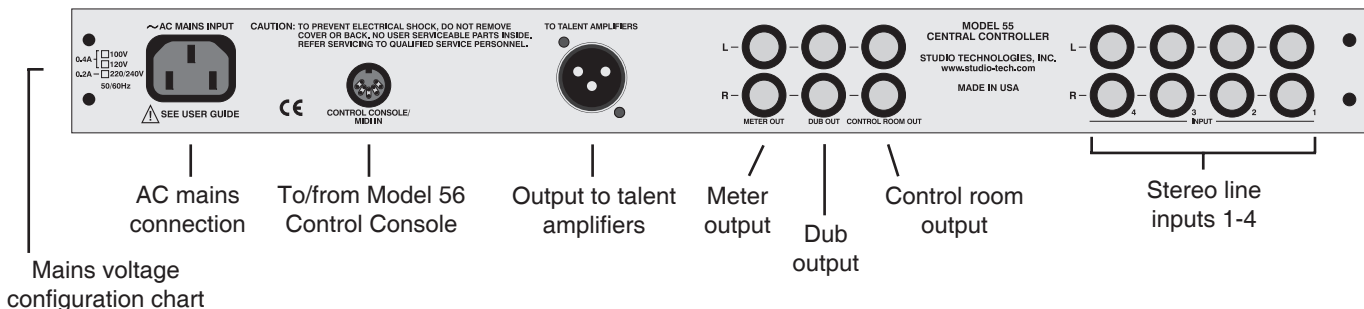



## Model 56 Front Panel

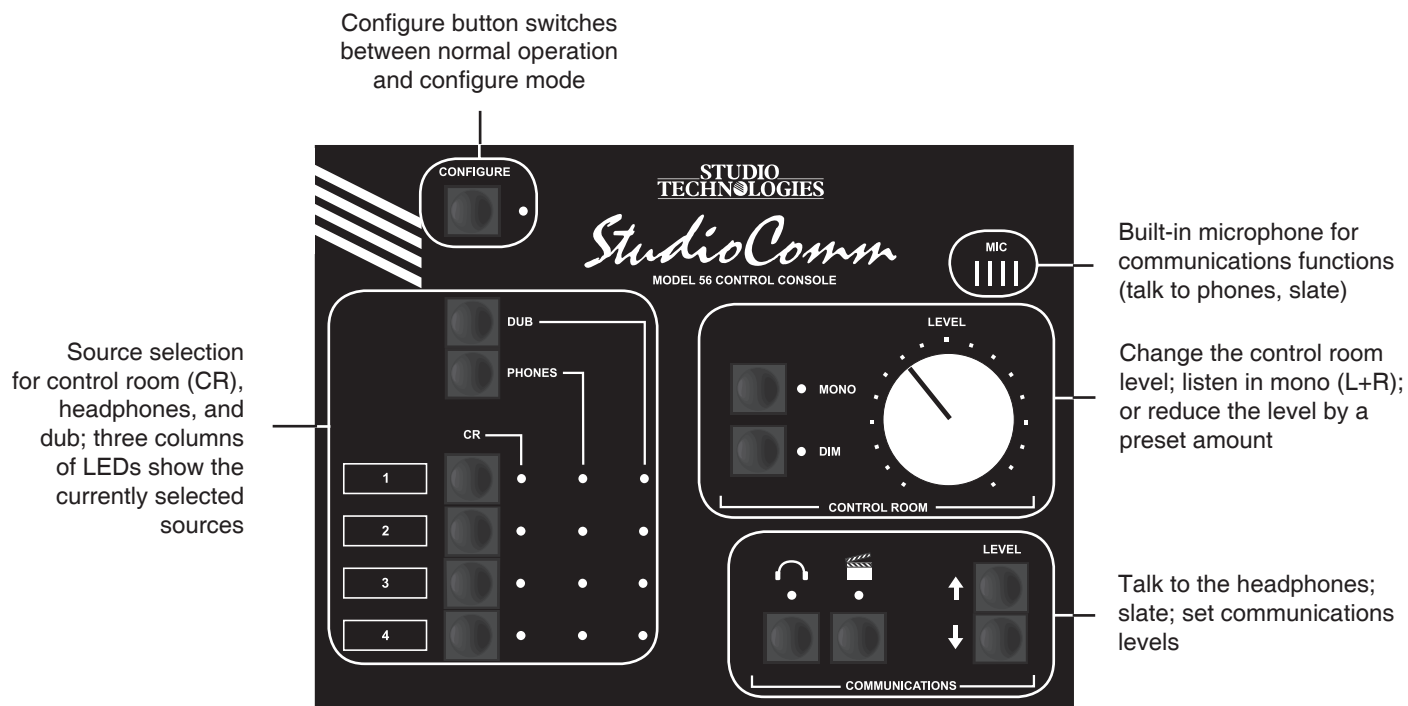

## Model 56 Back Panel



Connection to the Model 55 Central Controller

### Configuration

The Model 56 Control Console can be configured to make the system meet a user's exact operating environment. All configuration parameters, along with "power down" operation conditions, are stored in nonvolatile memory.

- Each of the four stereo line inputs can be independently set for  $-10$  dBV or  $+4$  dBu operating levels.

- Each input can be set for either mono or stereo operation. In the mono mode a signal connected to the left input is sent to the left and right outputs.
- The dub output level can be set for a nominal  $-10$  dBV or  $+4$  dBu output level.
- Unique to the system is the ability to configure the dim level to one of three values, allowing a 15, 20, or 25 dB reduction when dim is active.

- Three functions can be set for push-to-latch operation if desired: talk to phones, slate, and control room mono.
- The auto dim off function, when configured, allows any change in the control room level potentiometer to automatically turn off an active dim state.
- The slate function can be configured to talk to the dub output, or talk to both the dub and headphone outputs.
- The talk to phones function can be set to interrupt the normal phones source or add (sums) to the phones source.
- The system can be configured to allow only one input source, or one or two input sources to be selected as the control room source(s).

### Headphone Monitoring

The StudioComm system contains an integrated, full-featured headphone (cue) system. Up to four Model 35 Talent Amplifiers can be connected to the Model 55's talent amplifier output. A single 3-conductor microphone-type cable carries power and stereo audio.

Using the Model 56 Control Console, any of the four stereo inputs can be assigned to the talent amplifier output. The talk to phones and slate functions allow communications (voice) audio to be sent to the talent amps. The talent amplifier output is short circuit protected. Error conditions are displayed by the Over Current LED on the Model 55's front panel.

Each Model 35 Talent Amplifier can drive two sets of high-impedance headphones (>150 Ω). The audio output is loud, and very "clean." The units feature a built-in level control, a stereo/mono switch, and a power present LED.

### Model 35 Front Panel

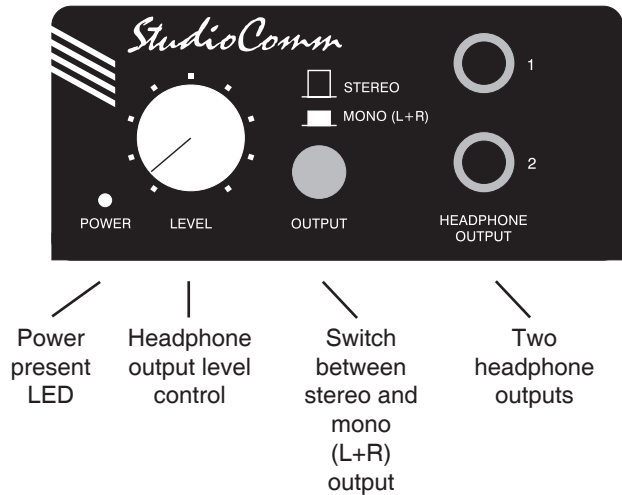

### Model 35 Back Panel

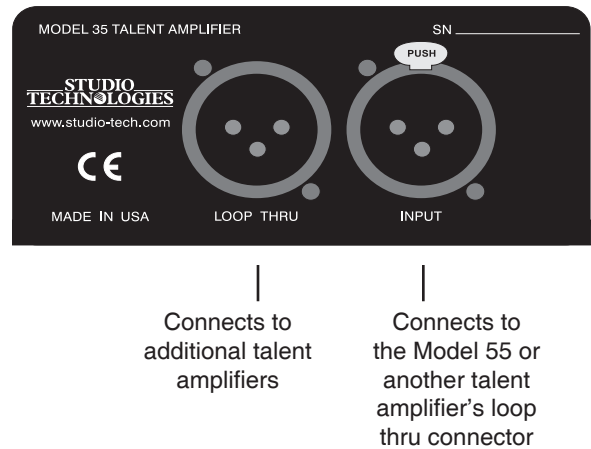

## Installation

In this section you will be installing the Model 55 Central Controller in an equipment rack. Audio input and output connections will be made using the Model 55's multitude of jacks. One or more Model 35 Talent Amplifiers may be connected. A location will be selected for the Model 56 Control Console, and it will be connected to the Model 55. AC mains power will be connected to the Model 55.

### System Components

The main StudioComm shipping carton contains a Model 55 Central Controller, Model 56 Control Console, 5-conductor MIDI-style cable, User Guide, and warranty card. Units destined for North America are shipped with an AC mains cord. Your dealer or distributor will provide an AC mains cord for non-North American destinations. Model 35 Talent Amplifiers, along with accessories, will be contained in separate cartons. Please check to ensure you have everything you need.

### Mounting the Model 55

The Model 55 requires one space in a standard 19-inch (48.3 cm) equipment rack. Select a location near where the Model 56 Control Console will be located. A cable is provided to connect the Model 55 to the Model 56. You can supply a longer cable, however 50 feet (15.3 m) is the recommended maximum length. It is desirable to locate the Model 55 to allow easy access to both the front and the back panels. The back panel contains all of the input and output connectors, while the front panel contains several LED indicators. The Model 55 is secured to the equipment rack using two mounting screws per side.

### Audio Inputs and Outputs

The Model 55's line-level audio input and output connections are made using ¼-inch 3-conductor phone jacks. For reliable audio interconnection, the plugs you use must comply with industry standard RS-453. Switchcraft No. 297, Neutrik NP3C, or equivalent will work correctly.

### Stereo Line Inputs

The Model 55 provides four stereo line-level inputs. Each input is electronically balanced, and can be configured for compatibility with -10 dBV or +4 dBu signal levels. The Model 56 Control Console gives you pushbutton control, so you can easily change input sensitivities at any time (refer to the Configuration section under Input Sensitivity). Monaural sources should be connected to the left (L) input and configured for mono operation (refer to the Configuration section under Stereo/Mono Input).

Prepare the mating connectors (plugs) so that tip is signal high (+ or hot), ring is low (- or cold), and sleeve is shield. With an unbalanced source connect the tip to high (+ or hot), and both the ring and sleeve to shield. If connecting to an unbalanced source in this manner results in hum or noise, connect tip to high (+ or hot) and ring to shield; leave the sleeve unterminated.

#### Balanced Input and Output Connections

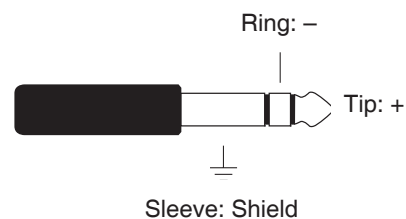

(Switchcraft No. 297, Neutrik NP3C, or equivalent)

### **Control Room Output**

The Model 55 contains a stereo line-level output for connection to an audio power amplifier. This audio amplifier serves a pair of loudspeakers that are located in the control room. (Of course the control room output can be connected to loudspeakers that contain integral power amplifiers, such as the products from Genelec.)

The output is electronically balanced and capable of driving loads of 600 ohms or greater. In most situations best performance will be obtained if the audio amplifier's input sensitivity is set to near maximum. Refer to the Technical Notes section for details on setting amplifier sensitivity.

The control room output utilizes two ¼-inch 3-conductor phone jacks for interconnection. Prepare the mating connectors (plugs) so that tip is signal high (+ or hot), ring is low (– or cold), and sleeve is shield. To connect to an unbalanced load connect the tip to high (+ or hot), and both the ring and sleeve to shield.

### **Meter Output**

The meter output is intended to be connected to a VU- or PPM-type meter panel that contains input buffer circuitry or series current-limiting resistors. Each output is unbalanced, has a nominal level of +4 dBu, and is capable of driving loads of 2 k ohms and greater.

The meter output utilizes two ¼-inch 3-conductor phone jacks for interconnection. Prepare the mating connectors (plugs) so that tip is signal high (+ or hot), sleeve is low (– or cold); ring is not connected.

### **Dub Output**

The Model 55 contains a stereo line-level output which is intended for connection to

a variety of analog audio devices. The dub output is electronically balanced and capable of driving 600 ohm loads or greater. With the input impedance of most audio devices at 10 k ohms or greater, the dub output can easily drive ten or more devices simultaneously.

The dub output can be configured for a nominal level of –10 dBV or +4 dBu, so you can connect to all line-level inputs with no hassle (refer to the Configuration section under Dub Output Level).

The dub output utilizes two ¼-inch 3-conductor phone jacks for interconnection. Prepare the mating connectors (plugs) so that tip is signal high (+ or hot), ring is low (– or cold), and sleeve is shield. To connect to an unbalanced load connect the tip to high (+ or hot), and both the ring and sleeve to shield.

### **Talent Amplifier Output**

Up to four Model 35 Talent Amplifiers can be connected in any combination to the Model 55's talent amplifier output. The output connector is a 3-pin male XLR-type. For best performance, use low-capacitance shielded microphone-type cable to distribute the talent amplifier signal. If you have a choice, select cables with the heaviest wire gauge commonly available. This will reduce voltage drop when using long cable runs. Refer to the Technical Notes section for additional information.

The simplest installation would use a microphone cable to connect the Model 55 to the first talent amplifier; the loop through connector on that talent amp sending the signal on to the next talent amp.

For convenience, you may want to wire your facility to allow easy access to the talent amplifier signal at all locations where talent amplifiers might be used. The talent amplifiers connect to the Model 55 in parallel, so the connectors on the distribution panels or mult boxes must be wired in parallel.

**Warning:** Do not connect the Model 55's talent amplifier output to anything but Studio Technologies' talent amplifiers. Some audio equipment may be damaged by the +23 Vdc contained on pin 2 of the talent amplifier output connector.

Several mounting options are available for the Model 35 Talent Amplifier. For details refer to Mounting Options in this section.

In special cases you may need to obtain a stereo, balanced line level output signal from the Model 55 talent amplifier output. The Model 70 Interface is available for this purpose. For details refer to the end of this section.

### **Locating the Model 56 Control Console**

The Model 56 was designed for desktop use, however provision has also been made for microphone-stand mounting. For details refer to Mounting Options in this section.

### **Connecting the Model 55 to the Model 56**

A standard 5-conductor MIDI-style cable is used to connect the Model 55 to the Model 56; a cable is included with your system. Just connect the cable between the female 5-pin DIN-type connectors on the back of the Model 55 and 56, and you're done.

**Note:** If you require a longer cable, be certain to buy a MIDI cable that has all five pins wired. If they aren't all connected, the Model 56 will not operate. This is because the Model 55 powers the Model 56 with the pins that aren't used for MIDI data.

For best performance, the cable that connects the Model 55 with the Model 56 should be limited to 50 feet (15.3 m). Should you need to exceed this length, refer to the Technical Notes section of this guide for details on the cable requirements.

For more information on MIDI, and using controllers other than the Model 56, please refer to Appendix A.

### **AC Mains Power**

The Model 55 is internally configured to operate from either 100, 120, or 220/240 V, 50/60 Hz. In most cases, units shipped to North America are factory selected for 120 V operation. Units bound for Japan are selected for 100 V, while our friends "down under" and in Europe receive units set for 220/240 V. Before connecting the Model 55 to mains power, check that it is configured to match the local mains voltage. Look on the back panel, adjacent to the power entry connector, for the configured voltage(s). Note that an incorrect configuration could seriously damage the unit. Should it be necessary to change the unit's operating voltage it must be performed only at the factory or by an authorized service technician.

The Model 55 uses an IEC standard connector to mate with the AC mains cord. The wire colors in the AC mains cord should conform to the internationally recognized CEE color code and must be wired accordingly:

<u>Connection</u>	<u>Wire Color</u>
Neutral (N)	Light Blue
Line (L)	Brown
Protective Earth (E)	Green/Yellow

**Safety Warning:** The Model 55 does not contain an AC mains disconnect switch. As such the mains cord plug serves as the disconnection device. Safety consideration requires that the plug and associated outlet be easily accessible to allow rapid disconnection of mains power should it prove necessary.

As soon as mains power is applied, the Model 55's power present LED will light. The Model 56 will go through its power-up sequence lighting each LED in a rapid sequence. The power present LEDs on the talent amplifiers will also light.

The Over Current LED located on the front panel of the Model 55 should not be lit. If it is flashing, immediately refer to the Troubleshooting section of this guide. If everything appears to be functioning properly you are now ready to configure the system.

### **Model 35 Stand Mounting**

Included with each Model 35 Talent Amplifier is a nifty mounting adapter that allows the unit to be conveniently attached to a microphone stand. Please refer to the Installation Guide provided in the Model 35's shipping carton for details.

### **Model 56 Mounting Options**

The Model 56 Control Console includes provisions for mounting to microphone stands, equipment consoles, etc. To avoid "reinventing the wheel," our products are compatible with the 25 Series components

from OmniMount Systems, a supplier of finely engineered mounting systems. This firm makes many versions of the 25 Series; one of which should fit your needs. If you desire microphone stand mounting the following components would be appropriate: 25RST-25H Straight Tube Reverse Mount with Quick Release, along with a 25MA Microphone Stand Adapter. (If quick adjustment is not required the 25RST Straight Tube Reverse Mount can be used in place of the first item.) When connecting to metric-thread stands please contact OmniMount for the correct part numbers.

The design of the Model 56 did not allow the inclusion of threaded inserts, so holes of adequate size to allow ¼-20 round head machine screws are provided. It is intended that screws of 5/8-inch length, along with lock washers and machine nuts, will securely attach a 25 Series mounting clamp assembly. The cover of the Model 56 will have to be removed to gain access to mounting holes. Be careful when selecting the mounting screws—exceeding the recommended 5/8-inch length will cause the mounting screws to damage the Model 56's internal components.

### **Model 70 Interface**

In most cases Model 35 Talent Amplifiers will be used to drive headphones associated with a StudioComm installation. In special cases a line level signal may be required to interface the Model 55 Central Controller's talent amplifier output with other audio equipment. An example would be to use the Model 55 with an existing headphone system. The Model 70 Interface is used to convert the talent amplifier signal to a stereo, balanced line level signal.

Installation is very simple. Connect the Model 70 to the Model 55 Central Controller's talent amplifier output using a standard 3-conductor microphone-type cable. For best performance, use low-capacitance shielded cable.

The Model 70 provides independent left and right balanced outputs. Pin 1 is shield, pin 2 is signal positive (+ or hot), and pin 3 is signal negative (– or cold). The electronically balanced outputs have a nominal signal level of +4 dBu and are capable of driving loads of 600 ohms or greater.

The Model 70 can be used by itself, or in conjunction with up to four Model 35 Talent Amplifiers. The loop through connector on the Model 70 can be used to connect to a Model 35 Talent Amplifier.

### Model 70 Front Panel

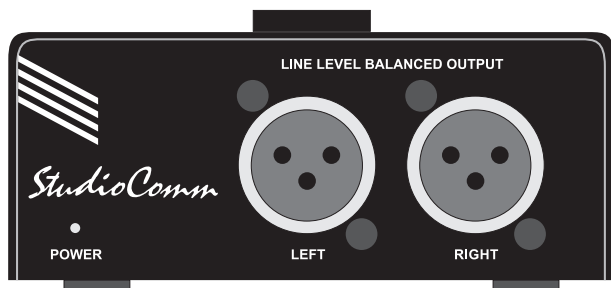

### Model 70 Back Panel

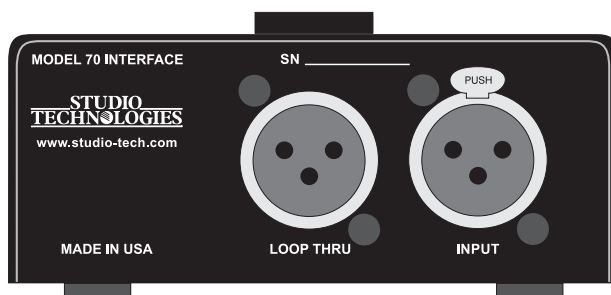

## Configuration

Many StudioComm functions can be configured to meet the exact needs of your installation. Here's an overview of what you can configure:

- –10 dBV or +4 dBu sensitivity for each input
- Stereo or mono for each input
- –10 dBV or +4 dBu level for the dub output
- Dim level
- Momentary or latching operation for mono, talk to phones, and slate buttons
- Auto dim off function
- Slate feed to phones
- Talk to phones interrupts or adds to phones source
- Allow simultaneous selection of two control room sources

The Configure button allows the Model 56 to go into the configure mode. While in the configure mode, all the Model 56's buttons and LEDs are associated with configure functions. Refer to the Model 56 Configuration Chart later in this section.

To enter the configure mode, press and hold the Configure button for two seconds. While in the configure mode, all audio outputs switch off and the orange LED beside the Configure button will flash. As you make changes, the Model 56 keeps track of the new settings and updates the system when you exit the configure mode. You must exit the configure mode before any changes take effect.

### **Input Sensitivity**

The CR column of four red LEDs shows you whether an input is set to be compatible with -10 dBV or +4 dBu signal levels. When a red LED in the CR column is off, it means the input is set to -10 dBV. When lit, the corresponding input is set to +4 dBu. Just press the CR buttons to toggle inputs 1 through 4 between -10 dBV and +4 dBu.

### **Stereo/Mono Input**

The Phones column of green LEDs indicates whether an input is configured for mono or stereo operation. When a green LED in this column is off, the input is set for stereo; the LED on means the corresponding input is set for mono. In mono mode, the left input is sent out both the left and right outputs. To toggle a channel between stereo and mono, press and hold the Phones button and press the CR buttons that correspond to inputs 1 through 4. After you leave the configure mode, inputs configured for a mono source will flash during normal operation.

### **Dub Output Level**

The Dub column of orange LEDs will help you configure two options: dub output level and dim level. The orange LED in the first row (number 1 at the top) tells you whether the dub output is set to -10 dBV or +4 dBu. When the LED is off, the dub output is set to -10 dBV; when it's on, the dub output is configured for +4 dBu.

### **Dim Level**

The dim function is used to reduce the control room output level a preset amount whenever you press the Dim button. You can take a quick phone call without using the level control to change the control room level. Also, any time you press the talk to

phones or slate buttons the dim function is activated.

In the configure mode, LEDs 2 through 4 in the Dub column indicate the selected dim level. Dim can only have a single setting, so only one of the orange LEDs is on at a time.

<u>Row Number</u>	<u>Dim Value (dB)</u>
2	25
3	20
4	15

When the orange LED is on in row two, dim is down 25 dB. Dim is down 20 dB in row three, and 15 dB in row four. To change the dim level, hold down the Dub button while pressing the CR button of your choice.

### **Mono Function**

The Mono function allows the control room output to be placed in the mono (L+R) mode. When you're in configure mode, the red LED labeled Mono tells you whether the Mono button works as a momentary or latching button. When the button is set to momentary, the LED will be off and mono mode will only be active while you press and hold the Mono button. When the LED is on, the button is set to latch. With this setting, you can press the Mono button once and it will remain in mono mode until you press it again.

### **Auto Dim Off**

The auto dim off function is unique to StudioComm products, making the dim function respond to real world operating conditions. When enabled the function automatically turns the dim function off if a change is made to the control room level potentiometer while the unit is already in dim mode. This prevents a heart-stopping



blast of audio when an engineer presses the dim button to turn dim on, but actually turns it off because the unit was already in the dim mode. While it's hard to explain unless you've used a console and experienced this in person, trust us, this situation does happen! Auto dim off is a wonderful "real-world" function and in most cases should be configured.

In the configure mode the Dim LED tells you if auto dim off is enabled. When the dim LED is off, the auto dim off function is off; when the Dim LED is lit, the auto dim off function is on.

### **Communications Functions**

There are two Communications buttons at the bottom center of the Model 56. Moving from left to right, the buttons are talk to headphones and slate. During configuration, LEDs above the Communications buttons tell you whether the buttons will latch when you press them. When an LED is off, the button below it won't latch. You would have to press and hold the button to activate the function. When an LED is on, it indicates that the button will latch. Pressing the button will activate the function until it's pressed again.

### **Alternate Configure Functions**

To allow additional functions to be configured, an alternate configure mode is utilized. By pressing and holding the Level Up button the alternate functions are accessed. This is like the ALT key on your personal-computer keyboard.

### **Slate to Phones**

When you press the slate button, the Model 56's microphone is fed to the dub output. This is how you can record your own voice for marking takes. But there

are times when it's convenient to have the slate provided in the headphone output as well.

While holding Level Up, the Phones LED is used to display whether the slate will go to the phones. When the LED is off, slate goes to the dub output only; when the LED is on, slate goes to both the dub and headphone outputs. While holding Level Up, press the button below the LED to toggle the setting.

### **Talk to Phones Interrupt or Add**

The talk to phones function can be configured to either interrupt the source selected for phones audio and connect communications audio, or to have the communications audio added (summed or mixed) with the phones audio.

While holding Level Up, the slate LED is used to display whether talk to phones will interrupt the phones source, or add to the phones source. When the LED is off, the selected phones source will be interrupted and the communications audio source will be connected; when the LED is on the communications audio source will be added (mixed) to the phones audio source. While holding Level Up, press the button below the LED to toggle the setting.

### **Allow Two Simultaneous Control Room Sources**

A feature has been added that allows any two of the four input channels to be simultaneously selected for monitoring over the control room output. This was added for applications where multiple "rough" or "scratch" audio signals need to be monitored at the same time. This feature can be enabled or disabled using the configuration procedure on the Model 56 Control Console.

### Reset Factory Defaults

Provision has been made to allow you to return all configurable parameters to the factory default values. With the Model 56 in the configure mode, press and hold both

the Dub and Phones buttons. After two seconds the factory defaults will be stored in memory, the configure mode will automatically end, and the Model 56 will return to normal operation.

## Model 56 Configuration Chart—Main Functions

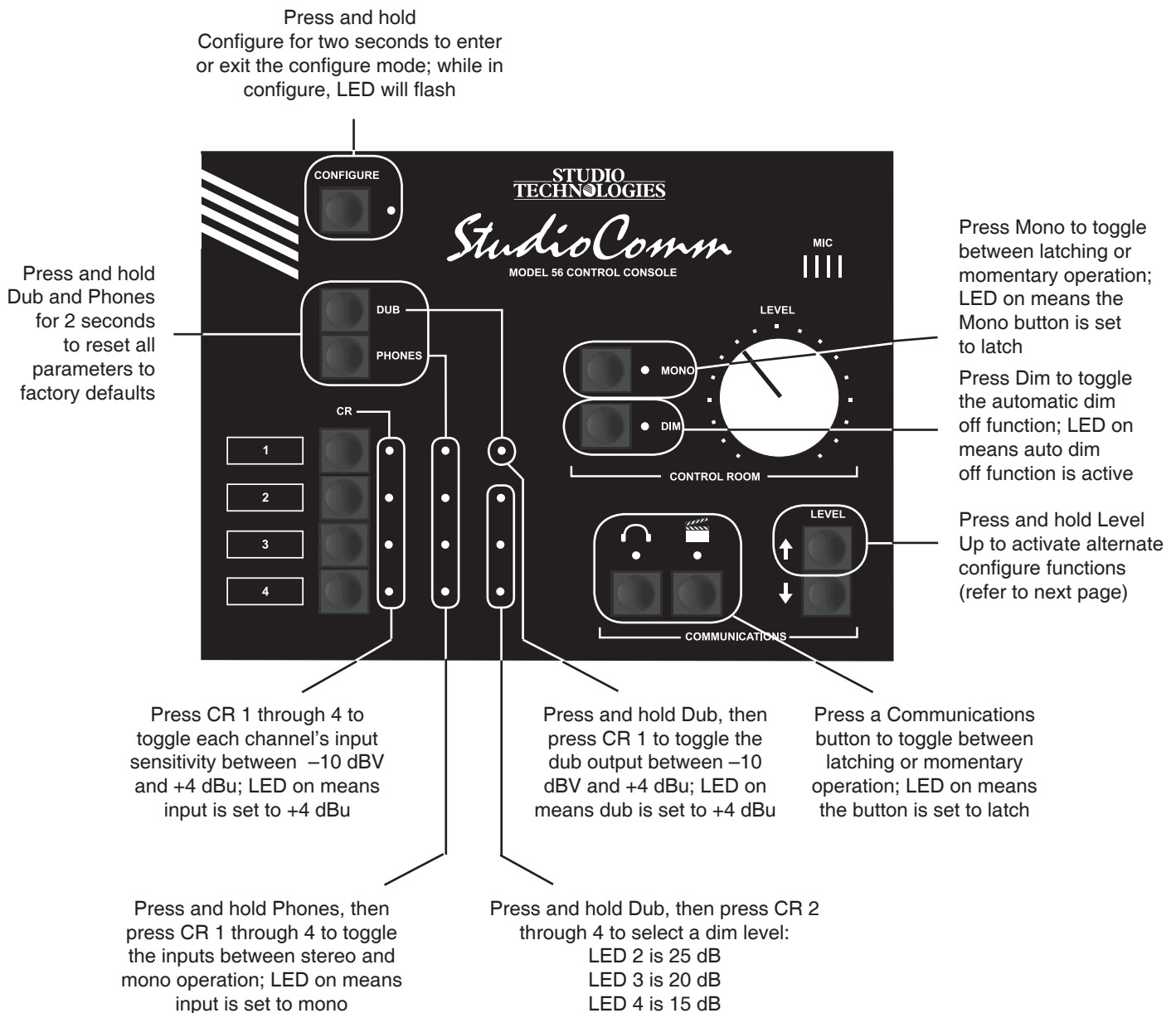

## Model 56 Configuration Chart—Alternate Functions

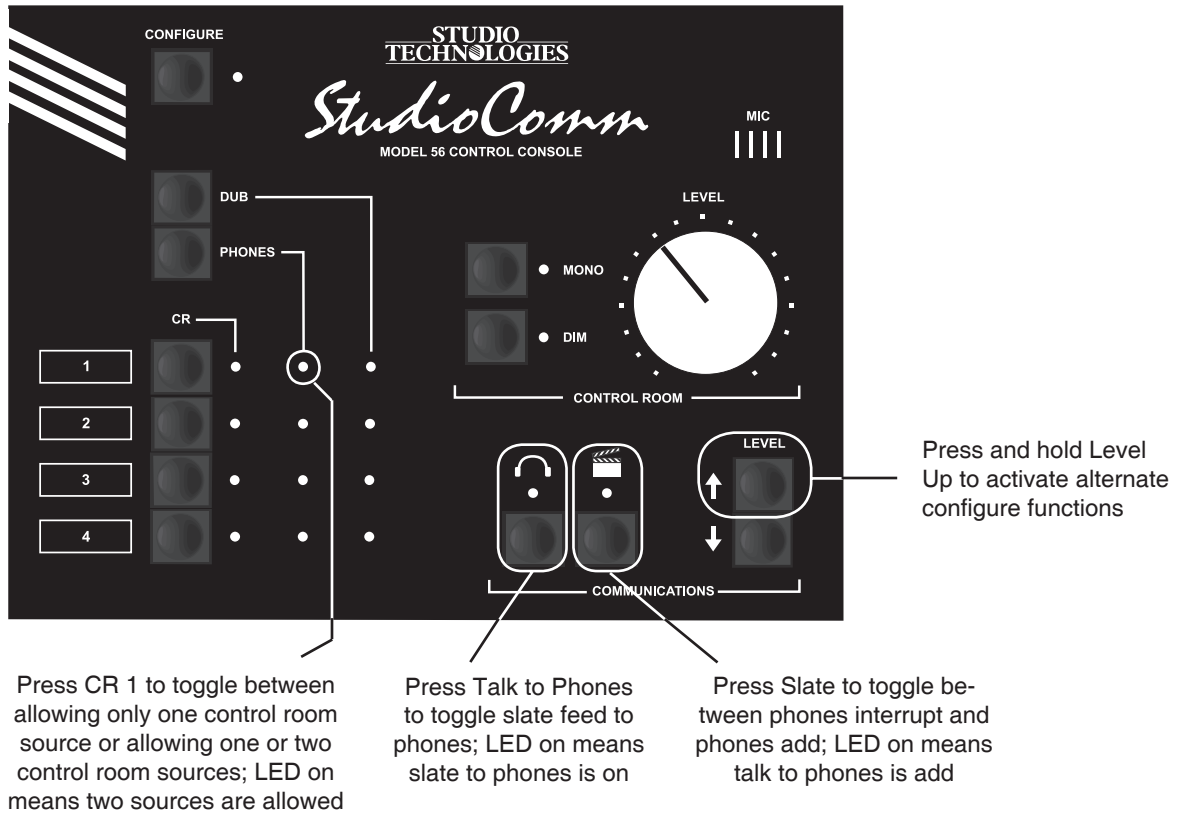

## Operation

Now that you've installed and configured the system, you're ready to go. You should find operation very easy.

### Model 55 Central Controller

The Model 55 front panel contains three LEDs. The power present LED should be lit whenever AC mains power is connected. During normal operation the Over Current LED will not be lit. It will flash only if there is a problem interfacing with the Model 56 Control Console or the talent amplifiers that you have connected. Refer to the Troubleshooting section if the Over Current LED lights.

The Input Data LED will light whenever a message is received. Refer to the Troubleshooting section if the LED does not flash in response to a message from the Model 56 Control Console.

### Model 56 Control Console

All StudioComm functions are controlled using the Model 56 Control Console. To make things easy, we've divided the StudioComm functions into three main groups: input-output selection, control room output, and communications functions.

#### Control Room/Meter Source Selection

To select an input for monitoring in the control room, press one of the four CR buttons. The corresponding LED in the CR column will light to let you know which input is selected. If the input is set for mono the LED will continually flash on and off as a warning. The same source will be connected to the meter output.

The system may have been configured to allow two control room sources to be selected simultaneously. If so, select the first source by pressing and holding one of the four CR buttons. Then, while keeping the first button pressed, select the second source by pressing one of the three other CR buttons. The two sources will be added (summed or mixed) together: L+L, R+R.

#### Headphone Source Selection

To select an input source for the headphone output, press and hold the Phones button and press one of the four CR buttons. In the Phones column, the LED for the input you select will light. If the input is set for mono the LED will continually flash on and off as a warning.

A special function allows you to select no input to be sent to the headphones. This ensures a quiet feed to the phones, but still allows the talk to phones function to be used. To select no input, simply press and hold the Phones button, then press both Communications Level buttons at the same time. The Level buttons are located to the right of the two Communications buttons. All LEDs in the Phones column will be off when no input is selected. To again select one of the four inputs, press and hold the Phones button, then press one of the four CR buttons.

#### Dub Source Selection

To select an input source for the dub output, press and hold the Dub button and press one of the four CR buttons. The appropriate LED in the Dub column will light. If the input is set for mono the LED will continually flash on and off as a warning. You can select no input just as you did for the headphones. Press and hold

the Dub button, then press both Level buttons at the same time.

### **Control Room Output**

Associated with the control room output are two buttons and one level control. In addition, the Communications Level buttons are used. Use the Control Room Level knob to set the control room output level. There is no on/off switch. Just select an input and turn the knob to the level you want.

The Dim button lets you lower the control room level by a fixed amount. The amount of attenuation depends on the dim level set in the configure mode (refer to the Configuration section for help). The Dim button is always set to latch the function on or off.

If the auto dim off function is enabled, whenever dim is on and the control room level is changed, dim will automatically return to the off state. Note that the auto dim off function is not active whenever dim is on due to one of the communications functions being active.

The Mono button lets you send L+R to both the left and right control room outputs. The Mono button can be configured for momentary or latching operation.

For diagnostic purposes, the control room left-only or right-only mode can be activated. To enter the mode you use the Communications Level buttons. Press and hold both Level buttons for two seconds. The control room will switch from stereo operation to the left-channel-only mode. Press and hold the Level buttons again, and the control room switches to right channel only. Press and hold the Level buttons a third time and the control room switches back to stereo operation. The

Level buttons continue to cycle through left, right, and stereo monitoring as you press them.

The Mono LED indicates when you are in left-only or right-only modes. During left-only operation the LED will flash once; in right-only operation the LED will flash twice.

Note that the mono function is disabled during single-channel operation. If mono is active when entering the single-channel mode, the system will terminate the mono mode.

### **Communications Functions**

Four buttons are associated with the communications functions. The two main buttons are called talk to phones and slate. They have symbols that represent (from left to right) a pair of headphones and a slate board (or “clapper”). Pressing each button activates the Model 56’s built-in microphone and sends its audio to the appropriate output(s). Press the button under the headphone symbol to talk to the headphones; press the button under the clapper to slate. Remember that during a slate, microphone audio goes to the dub output or, depending on the configuration, to the dub and phones output. When you press one of the communications buttons, the LED above it will come on to tell you the function is active. Note that only one communications function can be active at a time.

When you press the communication buttons, various things happen depending on the Model 56’s configuration. Either of these buttons may be configured to stay on (latch) when you press them. Also, if the headphones are configured to receive slate audio, both the phones and slate

LEDs will light when you press slate. The communications level to the headphones will be determined by the slate level setting (not the talk to phones level).

The talk to phones function is configured to interrupt or to add to the selected headphone source. If interrupt is selected, activating talk to phones disconnects the selected headphone source and connects communications audio. If add is selected, activating talk to phones leaves the headphone source connected and adds (sums or mixes) the communications audio.

You can independently set the output level for the two communications functions. To set the communications levels, press and hold either the talk to phones or slate button and press the Communications Level buttons. (If the talk to phones or slate buttons are set to latch, you won't have to hold them.) The LEDs above the buttons will flash each time the level is increased or decreased until you reach the top or bottom of the range. At this point, if you continue to press the same Level button, the LED won't flash, indicating you're at the top or bottom of the eight-step level range.

### **Headphone Level**

The headphone output level is controlled only at the Model 35 Talent Amplifier. There is no headphone level adjustment using the Model 56.

### **Configure Mode**

Refer to the Configuration section for an understanding of how to use the Configure button.

## **Model 35 Talent Amplifier**

**Warning:** protect your ears! The Model 35 talent amplifier is capable of driving headphones to extremely high sound pressure levels. Hearing experts advise against continuous extended play, especially at high levels.

The power present LED should be lit whenever the Model 35 is connected to an operating Model 55. The Model 35 has a Level control and a Stereo/Mono button. You can plug in one or two pairs of headphones with a total impedance of 75 ohms or greater. Turn the knob to the output level you want and select stereo or mono by pressing the button. Both headphone outputs are controlled by the one level control. The Mono button sends L+R to both the left and right output.

## **Troubleshooting**

If you're having problems getting the StudioComm system up and running, this section can help. If you haven't read the other sections of this guide, you should do so before proceeding.

### **If the Model 56 Doesn't Work At All**

Your StudioComm system was supplied with a 5-conductor DIN-type cable that is used to connect the Model 56 Control Console to the Model 55 Central Controller. This cable has an important characteristic; it implements all five conductors. This means that all five pins on each plug connect to each other using a length of 5-conductor cable. If you choose to use your own cable it's easy to get in trouble;

many MIDI cables only have three conductors! You **must** use a 5-conductor MIDI-style cable or the Model 56 will not power up and function. Five conductor MIDI cables are not hard to find, but you must ask for them and ensure that you get what you asked for. **Be warned!**

### **Over Current LED**

During normal operation the Over Current LED, located on the front panel of the Model 55, should not light. It will light, flashing on and off, in response to problems with the Model 56 Control Console and/or the Talent Amplifier output.

The Over Current LED will light if the power source that supplies the Model 56 Control Console is loaded to exceed its maximum output current. The most common reason for an over current condition would be a shorted 5-conductor MIDI-style interconnecting cable. A major fault in the Model 56 would also cause the LED to light.

The Over Current LED will also light if the talent amplifier output is loaded to exceed its maximum output current. The most common reason for an over current condition would be a shorted interconnecting cable. Also, connecting more than the specified maximum of four Model 35 Talent Amplifiers can also cause the LED to light. Possible, but not likely, would be a fault condition in a Model 35.

If the Over Current LED does light, troubleshooting should prove quite simple. Begin by disconnecting the cables that are plugged into the Control Console/MIDI In and the talent amplifier output connectors. Perform the disconnection directly on the Model 55's back panel. The LED should stop lighting. Now reconnect to Control

Console/MIDI In. If the LED again lights, follow this paragraph. If the LED does not light, skip to the next paragraph. Check the interconnecting cable that links the Model 55 with the Model 56 Control Console. You need to determine where the short circuit condition is located. The Model 55 will not be damaged if the Over Current LED is lighting so you should use it to help you locate the fault. In just a few minutes you should be able to isolate exactly if the cable or the Model 56 is causing the problem. Replace the cable if it proves to be bad—remember you'll need a MIDI-style cable with all five conductors connected. If the Model 56 appears to be at fault, it will need to be returned to the factory for repair.

If the LED did not light when you reconnected to Control Console/MIDI In, reconnect to the talent amplifier output. The LED should now light, identifying that the problem is with the talent amplifiers or associated cabling. In most cases you will find that a cable is at fault. If a talent amplifier is found to be at fault, it will need to be returned to the factory for repair.

### **Input Data LED**

The Input Data LED lights only when data is received that is valid for the Model 55. The Model 55 uses MIDI system-exclusive messages to perform all operations. When the Model 56 Control Console is connected to the Model 55, the LED will light any time the Model 56 generates data. This is because the Model 56 will only generate data that is compatible with the Model 55.

If you are not using the Model 56, and instead are supplying MIDI data using another device, the LED should prove extremely useful when troubleshooting. Only when the MIDI data conforms to the

Model 55's MIDI system-exclusive format will the LED light. Refer to Appendix A, located at the end of this guide, for details on how data must be sent to the Model 55.

### **Clicks in the Audio**

As covered in the Configuration section of the manual, the four stereo line inputs can be configured for  $-10$  dBV or  $+4$  dBu operation. Setting an input for  $-10$  dBV, while connecting an audio source with a  $+4$  dBu nominal level will lead to distortion ("clipping") of the signal. In this fault condition the user would hear a harsh "clicking" sounds in the audio, especially when peak levels occur in the program material. To remedy this problem simply use the Model 56 Control Console to configure the input for  $+4$  dBu operation. The distortion will go away and the gain structure of the StudioComm system will be correctly established.

## **Technical Notes**

### **Talent Amplifier Cable Length**

There are no hard and fast rules defining the maximum cable length when connecting Model 35 Talent Amplifiers to the Model 55 Central Controller. The maximum cable length is directly related to the amount of resistance in the connecting cable; the lower the resistance per foot (or meter), the longer the cable can be. (Although cable capacitance affects high frequency performance, resistance is the limiting factor in this case.)

To lay out the facts in grammar-school story-problem format: for correct operation, a Model 35 needs to see at least  $+20$  Vdc between pins 1 and 2 of their input connector. The Model 55's talent amplifier output voltage across pins 1 and 2 is  $+23$  Vdc,

with a maximum current draw of  $0.2$  A ( $200$  mA). This difference between the voltage supplied and the voltage required results in a maximum voltage drop of  $3$  V over the interconnecting cables. Since cable is rated in ohms per  $1000$  feet (or ohms per  $1000$  meters), you need to know what the maximum cable resistance is. This can be easily calculated by dividing the maximum voltage drop by the maximum current flow:  $3$  V divided by  $0.2$  A =  $15$  ohms. For example, a standard  $20$  AWG microphone cable is Belden 8412, which has  $10.9$  ohms resistance per conductor per  $1000$  feet. Since we're using two conductors to carry the signal (pins 1 and 2) you'd get  $21.8$  ohms per  $1000$  feet of microphone cable. With our  $15$  ohm maximum resistance you'd be able to use  $688$  feet ( $210$  m) of this cable.

By using the numbers provided you can select a cable, and its maximum length, for your application.

### **Model 55 to Model 56 Cable Length**

The Model 56 Control Console generates system-exclusive MIDI messages which are sent to the Model 55 Central Controller using a 5-conductor MIDI-style interconnecting cable. The MIDI signal is carried on two of the five conductors. The three remaining conductors are for common/shield, DC power, and communications audio. The limiting factor in the interconnecting cable's length is the transmission of the MIDI data, which has a rate of  $31,250$  bits-per-second. The inter-conductor capacitance of the cable attenuates the data, and as the cable length increases the data becomes unusable; the cable serves as a low-pass filter. The MIDI specification calls for a maximum cable length of  $50$  feet ( $15.3$  m), which will work fine connecting the Model 56 to the Model 55. There is



really no reason why this length can't be increased, as long as good low-capacitance, shielded cable is utilized. Runs of 100 to 250 feet (30.5 to 76.2 m) are possible using the latest sophisticated cable. Test to ensure that the StudioComm system works correctly with the desired cable length. There are too many variables to give a simple formula—good luck!

### **Definition of Level—dBu and dBV**

Whenever possible, Studio Technologies has opted to use the dBu designation as it seems to be quite rational. Using dBm was fine when all audio line outputs were terminated with 600 ohm loads. In this way it was easy to say that 0 dBm is 1 milliwatt dissipated in the known load (i.e., 0 dBm across 600 ohms will measure 0.775 V). In contemporary situations an output is rarely terminated with 600 ohms; generally 10 k ohms or higher. The dBu designation is better because it refers to dB referenced to 0.775 V, with no reference to load impedance. This takes into account today's audio scene where signals have a low source impedance, and a high input impedance. The dBu designation is becoming the standard for the professional audio industry.

StudioComm equipment is designed to interface with audio signals that have nominal signal levels of -10 dBV and +4 dBu. You might wonder why dBV came into the picture. Most people don't realize that equipment that utilizes "-10" levels usually mean -10 dBV—substantially different from -10 dBu (-10 dB V = -7.78 dBu). The dBV designation is simply a different way of measuring signal level and is often used when dealing with portable or consumer audio equip-

ment. The dBV designation refers to dB referenced to 1.0 V, rather than dBu which refers to 0.775 V.

### **“Hot” Disconnection of the Model 56 Control Console**

Should you need to relocate the Model 56 while your StudioComm system is operating, there is no reason why you can't disconnect the 5-conductor cable, move the unit, and then connect it again. If the Model 56 is disconnected while it is operating, the current operating parameters are saved in nonvolatile memory and the Model 55 Central Controller will continue to operate as it did when the link was broken. No clicks, pops, or other noises will occur when the Model 56 is again connected.

The Model 56 will go through its standard power-up sequence, send a message to reset power-up defaults, then send the operating parameters as stored in its memory. You may notice a brief interval of silence while the Model 55 responds to the reset defaults message.

### **Control Room Mono Function**

Many arguments were had while designing the control room monaural function. Was the function supposed to be a true mono function, sending the sum of left and right to a separate mono control room output? Was mono to be the sum of left and right sent to both left and right channels? What about level build up with phase coherent signals that are in both the left and right channels? After much head scratching it was realized that the mono function that most people are accustomed to is really a means of observing the character of a stereo mix, and not a “true” mono function. To observe the stereo image of a mix you need to sum the left

and right signals, drop the level, and send the result out the left and right outputs. In our application we drop the level by 6 dB. This is what many recording consoles implement, and is what the StudioComm does too!

### **Talent Amplifier Mono Function**

The Model 35 Talent Amplifiers contains a monaural switch. The mono function sums the left and right input signals, drops the level of the sum by 6 dB, and sends the sum to both the left and right outputs.

### **Input Level and the Talent Amplifiers**

Optimal performance of the Model 35 Talent Amplifier depends on the headphone source signal levels being at approximately the nominal input level, either -10 dBV or +4 dBu, depending on the configuration. The headphone volume is adjusted only by the level controls on the talent amplifiers. If the selected headphone source signal level is significantly less than nominal, the talent amplifier will simply not be able to create the maximum volume in the headphones. While there is some gain in the talent amplifiers, optimal performance still requires an input close to nominal.

### **Communication Switch Noise**

During field trials of the StudioComm components one item came up for discussion concerning “thumps” in the communications functions. A brief discussion may be useful. Electrically the Model 55 and Model 56 electronics that support the communications functions are quite quiet, not adding appreciable “clicks, pops, or thumps.” Software time delays are even added to minimize noise when a button is pressed. Mechanical noise being picked up by the Model 56’s microphone can be an issue.

If the talk to phones or slate buttons are pushed using a relatively light touch no objectionable noise will be generated; pressing the switches with “gusto” will cause mechanical noise to be transferred into the microphone. While the Model 56’s microphone is of good quality, shock mounting it was not possible using a cost-effective method. The fact that the Model 56 is physically small and the buttons must be relatively close to the microphone adds to the difficulty. (Note that most all recording consoles, both small and large, share this condition.) So in conclusion, use a light touch on the buttons and everyone should stay reasonably happy!

### **Power Amplifier Input Sensitivity**

Optimum StudioComm performance is obtained when the input sensitivity of the control room power amplifier is adjusted to match the Model 55’s output level. With normal, but loud, listening levels you should find the level potentiometer on the Model 56 to be set to about 11 or 12 o’clock. If you find that you don’t have to turn up the Model 56’s control that high, reduce the input sensitivity of the power amplifier. Most power amplifiers have controls on their inputs to allow easy adjustment of the input sensitivity.

### **Control Room Output Transient Protection**

Unique to the Model 55 Central Controller is a power up/power down transient protection feature. It limits the chance of damage to the control room loudspeakers during the time when AC mains voltage is connected, disconnected, or has significantly changed from nominal. A combination of hardware and software is used to monitor one of the power supply “rails.”

Until the rail voltage exceeds 81% of its nominal value, an electromechanical relay maintains a short circuit condition on the control room output. After a one-second delay the relay is released to function normally. Whenever the rail voltage drops below 79% of its nominal value, the relay immediately goes to its mute state. During testing it was found that upon power up the control room output remained very quiet; during power down a moderate “tick” was the worst that was heard.

# Specifications

## Model 55 Central Controller

**Audio Inputs:** 4, stereo

**Type:** electronically balanced, direct coupled, compatible with balanced or unbalanced signals

**Impedance:** 24 k ohms

**Nominal Input Level:** -10 dBV or +4 dBu, each input individually software configurable

**Common Mode Rejection:** 100 dB @ DC and 60 Hz, 70 dB @ 20 kHz, 62 dB @ 40 kHz (typical)

**Control Room Output:** 1, stereo

**Type:** electronically balanced, intended to drive loads of 600 ohms or greater, balanced or unbalanced

**Nominal Level:** unity gain, audio inputs to control room outputs

**Maximum Output Level:** +27 dBu into 10 k ohms, +26 dBu into 600 ohms

**Frequency Response:** 10 Hz-40 kHz +0/-0.5 dB (down 1 dB @ 80 kHz)

**Distortion (THD+N):** 0.03% (measured at +4 dBu input, +4 dBu output)

**S/N Ratio:** 87 dB (20 Hz-20 kHz)

**Dub Output:** 1, stereo

**Type:** electronically balanced, intended to drive loads of 600 ohms or greater, balanced or unbalanced

**Nominal Output Level:** -10 dBV or +4 dBu, software configurable

**Maximum Output Level:** +27 dBu into 10 k ohms, +26 dBu into 600 ohms

**Frequency Response:** 10 Hz-40 kHz +0/-0.5 dB (down 1 dB @ 70 kHz)

**Distortion (THD+N):** 0.004% (measured at +4 dBu input, +4 dBu output)

**S/N Ratio:** 92 dB (20 Hz-20 kHz)

**Meter Output:** 1, stereo

**Type:** unbalanced, intended to drive loads of 2 k ohms or greater

**Nominal Output Level:** +4 dBu

**Maximum Output Level:** +21 dBu into 10 k ohms

**Frequency Response:** 10 Hz-40 kHz +0/-0.5 dB (down 1 dB @ 70 kHz)

**Distortion (THD+N):** 0.004% (measured at +4 dBu input, +4 dBu output)

**S/N Ratio:** 92 dB (20 Hz-20 kHz)

**Talent Amplifier Output:**

**Application:** provides power and audio signals for up to four Model 35 Talent Amplifiers. The output connector (3-pin XLR-type, male) has common on pin 1, +23 Vdc modulated with left channel audio at -10 dBu on pin 2, and right channel audio at -10 dBu on pin 3. Maximum output current 200 mA (nominal).

**LED Indicators:** 3, power present, over current, and input data present

**Connectors:**

**Audio Inputs and Outputs:** ¼-inch, 3-conductor phone jacks.

**Talent Amplifier Output:** 3-pin XLR-type, male

**Control Console/MIDI In:** 5-pin DIN-type, female

**AC Mains:** 3-blade IEC-type

**AC Mains Requirement:** 100, 120, or 220/240 V, ±10%, factory configured, 50/60 Hz, 100-120 V 0.4 A maximum, 220/240 V 0.2 A maximum

**Dimensions (Overall):**

19.00 inches wide (48.3 cm)

1.72 inches high (4.4 cm)

8.75 inches deep (22.2 cm)

**Mounting:** one space in a standard 19-inch rack

**Weight:** 8.5 pounds (3.9 kg)

## Model 56 Control Console

**Power Requirements:** 15 Vdc filtered and regulated, 75 mA maximum, provided by Model 55 Central Controller

**Connectors:**

**To Model 55 Central Controller:** 5-pin DIN-type, female

**Internal Microphone:**

**Type:** electret condenser

**Frequency Response:** 3 dB roll off at 105 Hz

**Dimensions (Overall):**

7.2 inches wide (18.3 cm)  
2.2 inches high (5.6 cm)  
5.4 inches deep (13.7 cm)

**Mounting:** desktop; provision for stand mounting provided

**Weight:** 1.7 pounds (0.8 kg)

## Model 35 Talent Amplifier

**Power Requirements:** +20-32 Vdc (modulated with left channel audio), provided by Model 55 Central Controller

**Power Present LED:** red, indicates presence of operating power

**Connectors:**

**Input (from Model 55):** 3-pin XLR-type, female

**Loop Thru:** 3-pin XLR-type, male, connected in parallel with input connector

**Headphone Outputs:** 2, ¼-inch, 3-conductor (stereo) phone jacks

**Headphone Output:** 1, feeds two headphone jacks

**Load:** intended for connection to one or two pairs of headphones with total impedance of 75 ohms or greater

**Output Level:** user adjustable

**Maximum Output Voltage:** 16 V peak-to-peak into 150 ohms @ 1% THD+Noise, 400 Hz

**Distortion (THD+N):** 0.03%

**Frequency Response:** 20 Hz-20 kHz ±0.5 dB

**Dimensions (Overall):**

4.2 inches wide (10.7 cm)  
2.0 inches high (5.1 cm)  
5.3 inches deep (13.5 cm)

**Mounting:** desktop; provision for stand mounting available as option

**Weight:** 0.8 pounds (0.4 kg)

## Model 70 Interface

**Power Requirements:** +20-32 Vdc (modulated with left channel audio), provided by Model 55 Central Controller

**Power Present LED:** red, indicates presence of operating power

**Connectors:**

**Input (from Model 55):** 3-pin XLR-type, female

**Loop Thru:** 3-pin XLR-type, male, connected in parallel with input connector

**Left and Right Line Outputs:** 3-pin XLR-type, male

**Line Output:** 1, stereo

**Type:** electronically balanced, intended to drive loads of 600 ohms or greater, balanced or unbalanced

**Nominal Output Level:** +4 dBu

**Maximum Output Level:** +20 dBu into 10 k ohms, +19 dBu into 600 ohms

**Frequency Response:** 20 Hz-20 kHz +0/-0.5 dB

**Distortion (THD+N):** 0.02%

**Dimensions (Overall):**

4.2 inches wide (10.7 cm)  
2.0 inches high (5.1 cm)  
5.3 inches deep (13.5 cm)

**Weight:** 0.8 pounds (0.4 kg)

Specifications and information contained in this User Guide subject to change without notice.

# Appendix A

## Controlling the Model 55

The Model 55 Central Controller uses MIDI system-exclusive messages to control all functions. The Model 56 Control Console is programmed to generate a subset of what the Model 55 is capable of doing. By using standard MIDI messages, the Model 55 can be used for a wide range of special applications. Any device that can be programmed to send system-exclusive MIDI messages can be used to control the Model 55.

All MIDI messages to be acted upon are system-exclusive type (F0H). No channel mode, system common, or system real time messages are utilized. Studio Technologies, Inc. manufacturer's ID number is 00H 00H 56H. The Model 55's product device ID number is 02H.

Note that the 5-pin connector on the Model 55's back panel is wired somewhat differently from a standard MIDI input. While pins 4 and 5 meet the MIDI standard, the three remaining pins are implemented for use by the Model 56. Pin 1 supplies +15 Vdc power, pin 2 is shield (ground), and pin 3 is communications audio input.

If you're connecting your own controller, such as a computer's MIDI interface, you might be concerned about the DC power on pin 1. Because the MIDI standard doesn't use this pin, it is highly unlikely that it will be connected inside your controller, so there's little chance of the DC causing damage. To be safe, you can use a MIDI cable with only two or three wires implemented.

The following pages provide a detailed list of all Model 55 system-exclusive MIDI messages.

### Function: Reset to Power Up Default Configuration

Byte	Value	Description
1	F0H	System-Exclusive Message
2	00H	1st Byte of Studio Tech ID
3	00H	2nd Byte of Studio Tech ID
4	56H	3rd Byte of Studio Tech ID
5	02H	Product ID (Model 55)
6	00H	Function: Restore Power Up Default Configuration
7	F7H	EOX, End of System Exclusive

### Action taken after Model 55 receives MIDI message:

1. Set control room level to minimum.
2. Set control room source 1 to no input.
3. Set control room source 2 to no input.
4. Set headphone source to no input.
5. Set dub source to no input.
6. Set control room output to off.
7. Set mono to off (stereo mode).
8. Set all input levels to +4.
9. Set dub output level to +4.
10. Set dim to normal, non-dim
11. Set dim level to 20 dB.
12. Set talk to headphones to off.
13. Set slate to off.

### Function: Input Level

Byte	Value	Description
1	F0H	System-Exclusive Message
2	00H	1st Byte of Studio Tech ID
3	00H	2nd Byte of Studio Tech ID
4	56H	3rd Byte of Studio Tech ID
5	02H	Product ID (Model 55)
6	01H	Function: Input Level
7	0nH	Input Channel, range 1-4, 1=input 1, 2=input 2, etc.
8	0nH	Input Level, range 0-1, 0=-10, 1=+4
9	F7H	EOX, End of System Exclusive

### Function: Dub Output Level

Byte	Value	Description
1	F0H	System-Exclusive Message
2	00H	1st Byte of Studio Tech ID
3	00H	2nd Byte of Studio Tech ID
4	56H	3rd Byte of Studio Tech ID
5	02H	Product ID (Model 55)
6	02H	Function: Output Level
7	0nH	Output Channel, range 1, 1=dub out
8	0nH	Output Level, range 0-1, 0=-10, 1=+4
9	F7H	EOX, End of System Exclusive

**Function: Control Room Source 1**

Byte	Value	Description
1	F0H	System-Exclusive Message
2	00H	1st Byte of Studio Tech ID
3	00H	2nd Byte of Studio Tech ID
4	56H	3rd Byte of Studio Tech ID
5	02H	Product ID (Model 55)
6	03H	Function: Control Room Source 1
7	mnH	Source Selected, m range 0-2: 0=stereo, 1=left only, 2=right only; n range 0-4: 0=no input, 1=input 1, 2=input 2, etc.
8	F7H	EOX, End of System Exclusive

**Function: Control Room Source 2**

Byte	Value	Description
1	F0H	System-Exclusive Message
2	00H	1st Byte of Studio Tech ID
3	00H	2nd Byte of Studio Tech ID
4	56H	3rd Byte of Studio Tech ID
5	02H	Product ID (Model 55)
6	04H	Function: Control Room Source 2
7	mnH	Source Selected, m range 0-2: 0=stereo, 1=left only, 2=right only; n range 0-4: 0=no input, 1=input 1, 2=input 2, etc.
8	F7H	EOX, End of System Exclusive

**Function: Headphone Source**

Byte	Value	Description
1	F0H	System-Exclusive Message
2	00H	1st Byte of Studio Tech ID
3	00H	2nd Byte of Studio Tech ID
4	56H	3rd Byte of Studio Tech ID
5	02H	Product ID (Model 55)
6	05H	Function: Headphone Source
7	mnH	Source Selected, m range 0-2: 0=stereo, 1=left only, 2=right only; n range 0-4: 0=no input, 1=input 1, 2=input 2, etc.
8	F7H	EOX, End of System Exclusive

**Function: Dub Source**

Byte	Value	Description
1	F0H	System-Exclusive Message
2	00H	1st Byte of Studio Tech ID
3	00H	2nd Byte of Studio Tech ID
4	56H	3rd Byte of Studio Tech ID
5	02H	Product ID (Model 55)
6	06H	Function: Dub Source
7	mnH	Source Selected, m range 0-2: 0=stereo, 1=left only, 2=right only; n range 0-4: 0=no input, 1=input 1, 2=input 2, etc.
8	F7H	EOX, End of System Exclusive



### Function: Control Room Level

Byte	Value	Description
1	F0H	System-Exclusive Message
2	00H	1st Byte of Studio Tech ID
3	00H	2nd Byte of Studio Tech ID
4	56H	3rd Byte of Studio Tech ID
5	02H	Product ID (Model 55)
6	07H	Function: Control Room Level
7	0nH	Level, MSB, range 0-3, see notes
8	nnH	Level, LSB, range 00-7F, see notes
9	F7H	EOX, End of System Exclusive

#### Notes:

MSB=0 allows LSB to control lower 128 level steps, MSB=1 allows LSB field to control upper 128 level steps. During operation MSB=0/LSB=00 gives minimum output level (maximum attenuation), MSB=1/LSB=7F gives maximum output level.

MSB=2 places function in reduced precision mode, where LSB=00 gives minimum output level (maximum attenuation), LSB=7F is maximum output.

MSB=3 places function in reduced precision, reverse range mode, where LSB=7F gives minimum output level (maximum attenuation), LSB=00 is maximum output.

### Function: Control Room Output Select

Byte	Value	Description															
1	F0H	System-Exclusive Message															
2	00H	1st Byte of Studio Tech ID															
3	00H	2nd Byte of Studio Tech ID															
4	56H	3rd Byte of Studio Tech ID															
5	02H	Product ID (Model 55)															
6	09H	Function: Control Room Output Select															
7	nnH	Output Selected, Range 00-11: <table border="1" style="margin-left: 20px;"> <thead> <tr> <th><u>L Ch.</u></th> <th><u>R Ch.</u></th> <th><u>Action</u></th> </tr> </thead> <tbody> <tr> <td>0</td> <td>0</td> <td>No Output</td> </tr> <tr> <td>1</td> <td>0</td> <td>Left Only</td> </tr> <tr> <td>0</td> <td>1</td> <td>Right Only</td> </tr> <tr> <td>1</td> <td>1</td> <td>Left and Right</td> </tr> </tbody> </table>	<u>L Ch.</u>	<u>R Ch.</u>	<u>Action</u>	0	0	No Output	1	0	Left Only	0	1	Right Only	1	1	Left and Right
<u>L Ch.</u>	<u>R Ch.</u>	<u>Action</u>															
0	0	No Output															
1	0	Left Only															
0	1	Right Only															
1	1	Left and Right															
8	F7H	EOX, End of System Exclusive															

### Function: Control Room Mono/Stereo Select

Byte	Value	Description
1	F0H	System-Exclusive Message
2	00H	1st Byte of Studio Tech ID
3	00H	2nd Byte of Studio Tech ID
4	56H	3rd Byte of Studio Tech ID
5	02H	Product ID (Model 55)
6	0AH	Function: Control Room Mono
7	0nH	Output Selected, Range 0-1, 0=stereo, 1=mono
8	F7H	EOX, End of System Exclusive

### Function: Control Room Dim

Byte	Value	Description
1	F0H	System-Exclusive Message
2	00H	1st Byte of Studio Tech ID
3	00H	2nd Byte of Studio Tech ID
4	56H	3rd Byte of Studio Tech ID
5	02H	Product ID (Model 55)
6	0BH	Function: Control Room Dim
7	0nH	Status, Range 0-1, 0=No Dim, 1=Dim
8	F7H	EOX, End of System Exclusive

### Function: Talk to Headphones

Byte	Value	Description
1	F0H	System-Exclusive Message
2	00H	1st Byte of Studio Tech ID
3	00H	2nd Byte of Studio Tech ID
4	56H	3rd Byte of Studio Tech ID
5	02H	Product ID (Model 55)
6	0EH	Function: Talk to Headphones
7	0nH	Status, Range 0-2, 0=no talk to headphones, 1=talk to headphones (interrupt), 2=talk to headphones (add)
8	0nH	Level, range 1-8, 8 is loudest
9	F7H	EOX, End of System Exclusive

### Function: Slate

Byte	Value	Description
1	F0H	System-Exclusive Message
2	00H	1st Byte of Studio Tech ID
3	00H	2nd Byte of Studio Tech ID
4	56H	3rd Byte of Studio Tech ID
5	02H	Product ID (Model 55)
6	0FH	Function: Slate
7	0nH	Status, Valid Values 0, 1, and 3, 0=no slate, 1=slate to dub output, 3=slate to dub and headphone output
8	0nH	Level, range 1-8, 8 is loudest
9	F7H	EOX, End of System Exclusive

**Function: Set Dim Level**

Byte	Value	Description
1	F0H	System-Exclusive Message
2	00H	1st Byte of Studio Tech ID
3	00H	2nd Byte of Studio Tech ID
4	56H	3rd Byte of Studio Tech ID
5	02H	Product ID (Model 55)
6	10H	Function: Set Dim Level
7	0nH	Status, Range 0-5: 0=full mute (approx. 70 dB) 1=30 dB dim 2=25 dB dim 3=20 dB dim 4=15 dB dim 5=10 dB dim
8	F7H	EOX, End of System Exclusive

**Function: Control Room Mute**

Byte	Value	Description
1	F0H	System-Exclusive Message
2	00H	1st Byte of Studio Tech ID
3	00H	2nd Byte of Studio Tech ID
4	56H	3rd Byte of Studio Tech ID
5	02H	Product ID (Model 55)
6	11H	Function: Control Room Mute
7	0nH	Status, Range 0-1, 0=No Mute, 1=Mute
8	F7H	EOX, End of System Exclusive

This page intentionally left blank.

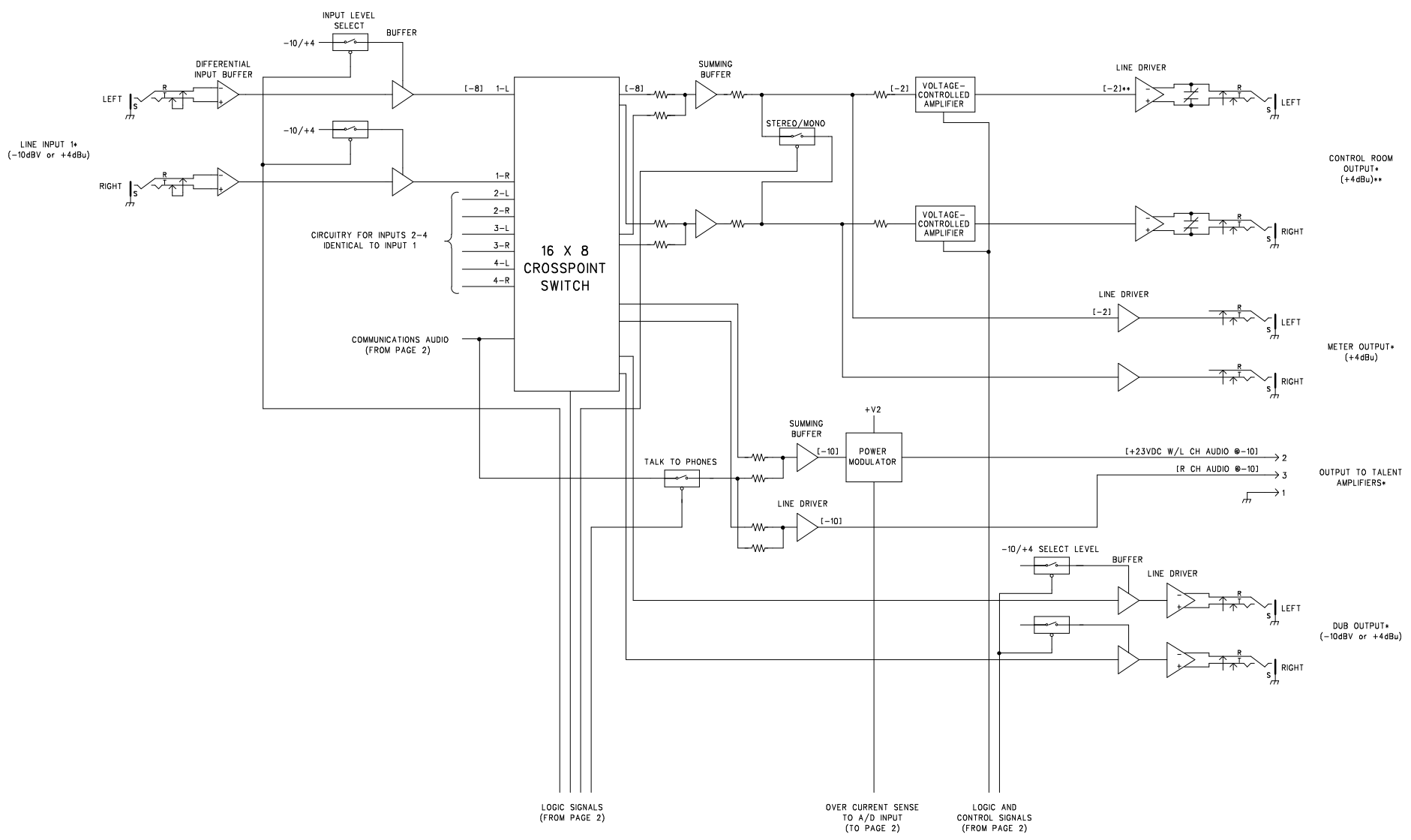

FOR SERIAL NUMBERS 00280 AND LATER

\* LOCATED ON BACK PANEL  
 \*\* W/LEVEL CONTROL AT MAXIMUM  
 (NOMINAL LEVEL IN dBu)

STUDIO TECHNOLOGIES, INC.		
MODEL 55 CENTRAL CONTROLLER BLOCK DIAGRAM		
DRAWING NO.	DATE	PAGE
30348	06/07/02	01 OF 02

M55BD\_C

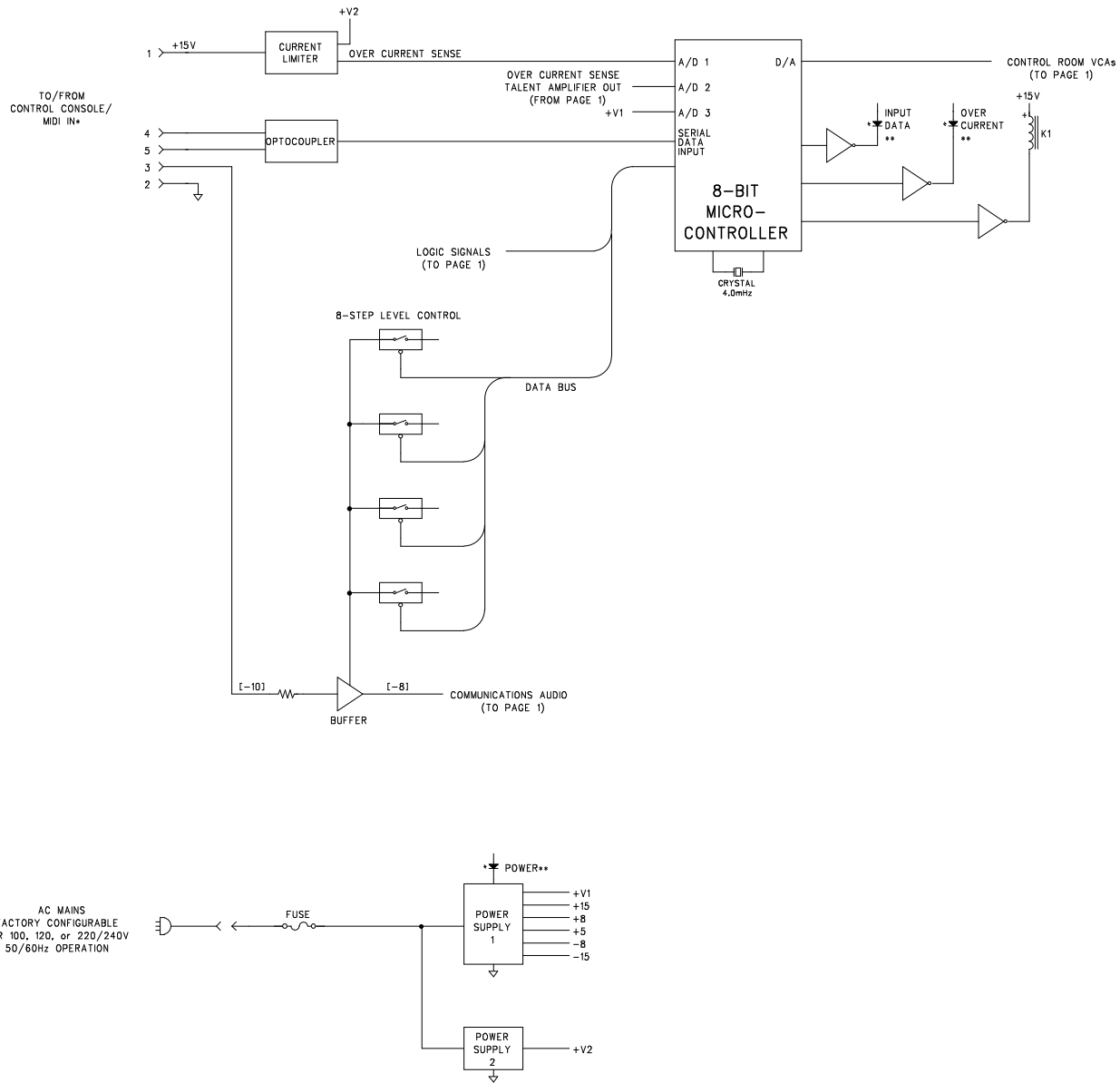

FOR SERIAL NUMBERS 00280 AND LATER

\* LOCATED ON BACK PANEL  
 \*\* LOCATED ON FRONT PANEL  
 (NOMINAL LEVEL IN dBu)

STUDIO TECHNOLOGIES, INC.		
MODEL 55 CENTRAL CONTROLLER BLOCK DIAGRAM		
DRAWING NO. 30348	DATE 06/07/02	PAGE 02 of 02

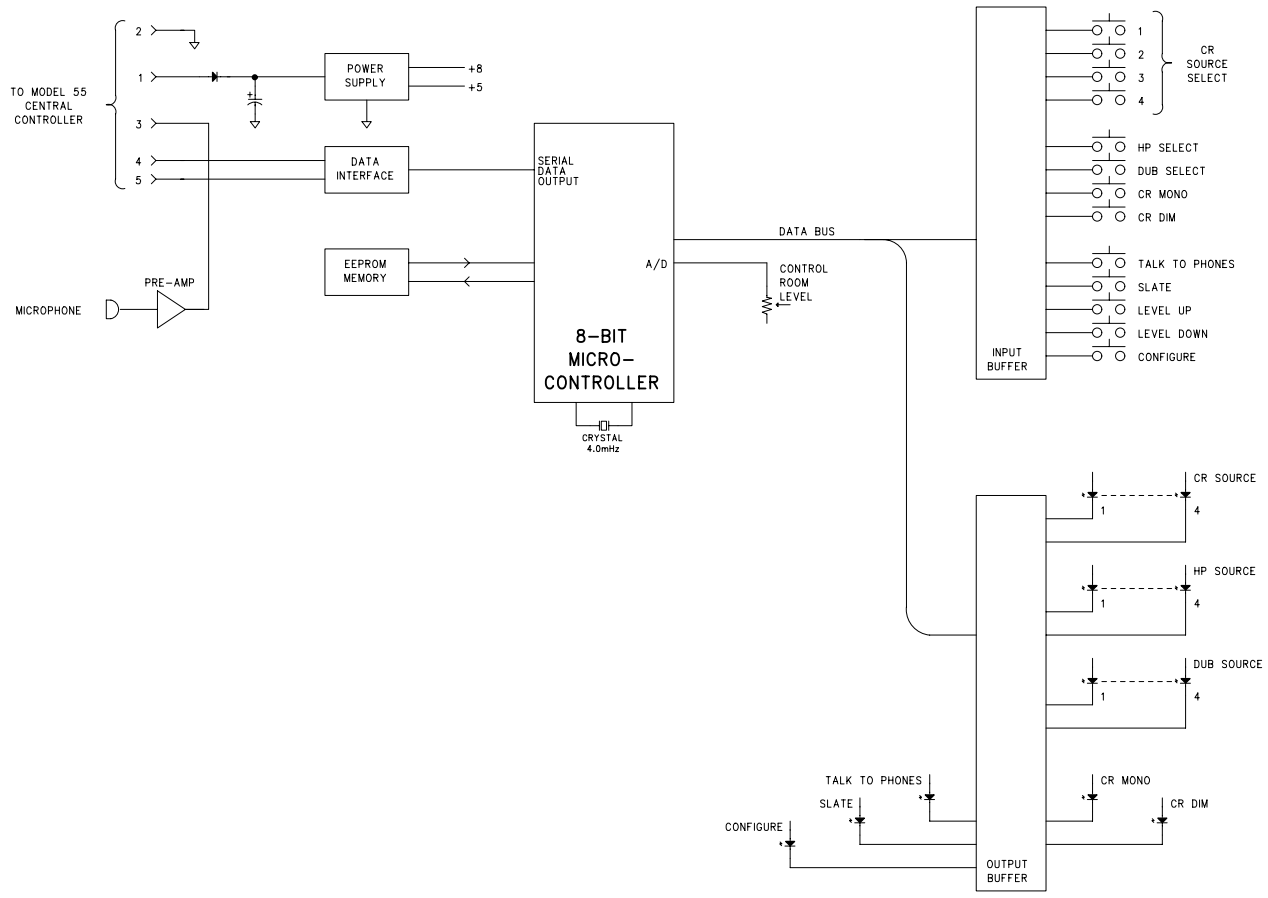

M56BD\_B

STUDIO TECHNOLOGIES, INC.		
MODEL 56 CONTROL CONSOLE BLOCK DIAGRAM		
DRAWING NO. 30351	DATE 12/03/96	PAGE 01 OF 01

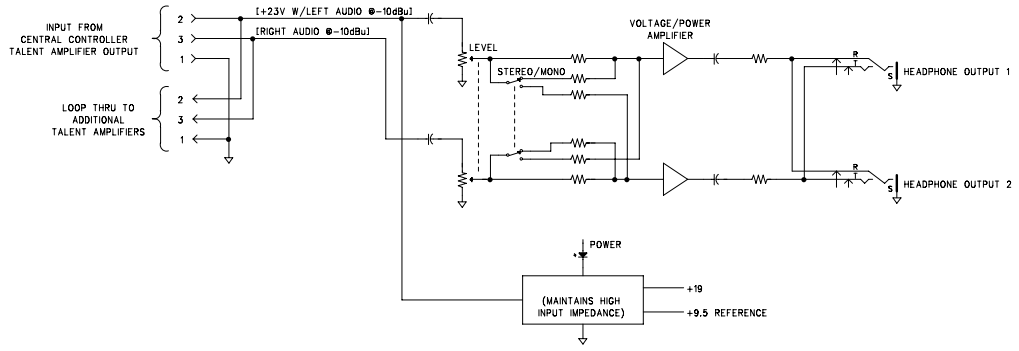

(NOMINAL LEVEL IN dBu)

M358D\_C

STUDIO TECHNOLOGIES, INC.		
MODEL 35 TALENT AMPLIFIER BLOCK DIAGRAM		
DRAWING NO.	DATE	PAGE
30312	08/12/05	01 OF 01



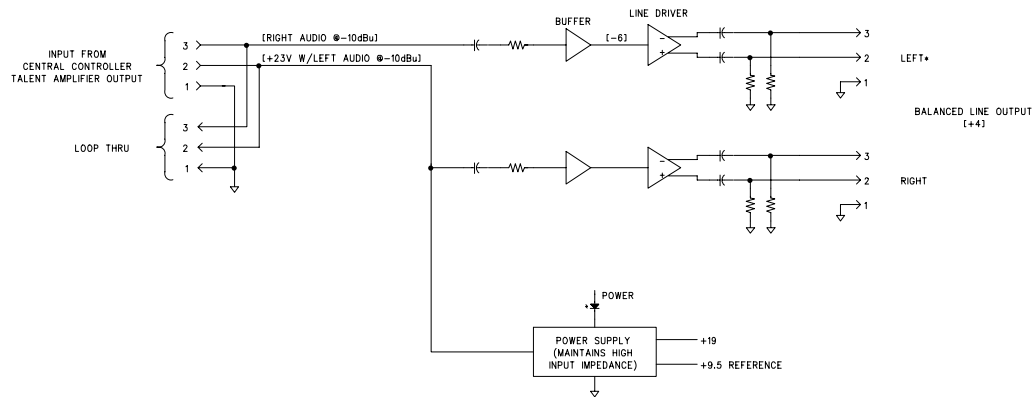

M70BD\_A

STUDIO TECHNOLOGIES, INC.

MODEL 70 INTERFACE  
BLOCK DIAGRAM

\* PIN 2 SIGNAL HIGH (+ OR HOT)  
(NOMINAL LEVEL IN dBu)

DRAWING NO.	DATE	PAGE
30458	12/09/03	01 OF 01