

# *StudioComm*

## **Model 50 Central Controller, Model 51 Control Console, and Related Components**

### **User Guide**

Issue 6, September 2004

This User Guide is applicable for systems consisting of:  
Model 50, serial number M50-00457 and later;  
Model 51, serial number M51-00457 and later

**© 2004 by Studio Technologies, Inc., all rights reserved**

[www.studio-tech.com](http://www.studio-tech.com)

This page intentionally left blank.

# Table of Contents

Foreword .....	5
Introduction .....	7
Installation .....	12
Advanced Installation Topics .....	17
Configuration .....	19
Model 51 Configuration Chart—Main Functions .....	22
Model 51 Configuration Chart— Alternate Functions .....	23
Operation .....	25
Troubleshooting .....	30
Technical Notes.....	32
Specifications.....	36
Appendix A.....	39
MIDI Messages .....	40
Block Diagrams	
Model 50 Central Controller	
Model 51 Control Console	
Model 35/Model 38 Talent Amplifiers	
Model 70 Interface	

This page intentionally left blank.

## Foreword

I am pleased to present the StudioComm series of products. As both president and owner of Studio Technologies, I take a very personal approach when designing products. Getting older has increased my appreciation of the more subtle things in life—be they a part of nature or the nuances contained in a well-designed piece of electronic equipment. Do the technical and operational aspects of a product work together to “feel” right? A Studio Technologies’ design is ready to go only when I am completely satisfied. My entire focus for the StudioComm series was to make a system that you’d really enjoy using, and one that would perform reliably for years. I hope you share my enthusiasm.

Many fine people worked toward making the StudioComm “happen.” Mitch Budniak (ace consulting engineer) designed many of the circuits. Jim Cunningham contributed to the analog design. Larry Leviton wrote the excellent micro-controller software. Al Lux designed the printed circuit boards. Carrie Loving designed the graphics. Fred Roeck performed the mechanical design. Joe Urbanczyk coordinated the safety testing and agency approvals.

Many thanks to Bob Tjarks, professional audio sales manager at Gand Music & Sound, Northfield, Illinois. Bob brought to my attention the need for a product to serve digital audio workstations. His product idea evolved into the StudioComm series. Additional thanks to Timothy Powell of Metro Mobile Recording, Glenview, Illinois, who provided his excellent ears when issues of sonic quality arose. His extensive field and studio experience was extremely helpful in keeping me on the audio “straight and narrow.”

Please contact me with your questions, comments, and suggestions. I can be reached by voice at (847) 676-9177, fax at (847) 982-0747, or via e-mail at [gkapes@studio-tech.com](mailto:gkapes@studio-tech.com).

Sincerely,

Gordon K. Kapes  
President

This page intentionally left blank.

# Introduction

## What This User Guide Covers

This User Guide is designed to assist you when installing, configuring, and using the Model 50 Central Controller, Model 51 Control Console, Model 35 Talent Amplifier, Model 38 Talent Amplifier, and related components.

## System Overview

The Model 50 Central Controller, along with the companion Model 51 Control Console, are members of the StudioComm family of products. The Models 50 and 51 are specifically designed to work in conjunction with digital audio workstations to provide a full set of monitoring and communications functions. Features include control room and studio monitoring, meter output, an integrated headphone system, dubbing, and communications functions that include talk to studio, talk to phones, and slate. All StudioComm functions perform to a level that rivals even the largest recording consoles. Many of the functions are user configurable, allowing unmatched flexibility.

The StudioComm system is designed to provide control over monitor and dub sources, communication from the control room to the studio, and a headphone monitoring (cue) system. A complete StudioComm system consists of a rack-mounted central controller, a desktop control console, and one or more portable talent amplifier units.

The Model 50 Central Controller and the Model 51 Control Console work together to provide performance and features for use in advanced applications. The

units interconnect using a standard 5-pin MIDI-style cable. Circuitry in the Model 50 separately routes any of seven stereo inputs to the control room, meter, studio, headphone, and dub outputs, with commands provided by the Model 51 Control Console. If you have MIDI software that supports the StudioComm system, you can even, in lieu of the Model 51, control the Model 50 with your computer.

The Model 51 Control Console's built-in microphone lets you talk to the studio or headphone outputs. It also allows you to talk to the dub output.

The Model 35 Talent Amplifier is a portable amplifier unit capable of driving one or two pairs of high-impedance stereo headphones. A single microphone-type cable links the Model 35 with the Model 50 Central Controller. The Central Controller provides power and left and right audio over just three wires.

The Model 38 Talent Amplifier takes the basics from the Model 35 and adds a unique stereo preamplifier section. This allows each Model 38 user to create an individual headphone mix, solving the classic problem of wanting "more me" in the phones! Like the Model 35, the Model 38 is linked to the Model 50 Central Controller by a single microphone-type cable.

## System Features

### Stereo Line Inputs

The Model 50 contains seven stereo line-level inputs which are compatible with both balanced and unbalanced signals. Each input is independently software configurable for a nominal input level of  $-10\text{dBV}$  or  $+4\text{dBu}$ . This allows direct connection with virtually any audio source.

Each input can also be configured to operate as a mono input. In this manner, a signal connected to the left input is routed to both the left and right outputs. For convenience, input 7 is located on the front panel of the Model 50; inputs 1 through 6 are located on the back panel.

### Control Room Monitoring

The control room section provides two stereo line-level outputs for driving two power amplifiers associated with monitor loudspeakers. Seven buttons are used to select the input source to be monitored. The control room level is adjusted using a smooth-feeling rotary potentiometer. The Dim button allows the control room level to be temporarily reduced. The Control

Room A/B button allows the control room A or B outputs to be activated. The Mono button allows the sum (L+R) of the selected source to be sent as the control room output.

### Meter Output

The meter output provides a stereo output that “follows” the source selected for the control room. The signal is not affected by the control room level circuitry, but is “post-mono.” The meter output is intended to be connected to VU- or PPM-type meters or meter panels that contain series current-limiting resistors or input buffer amplifiers. In addition, they must support meter calibration to ensure precision level reading.

## Model 50 Front Panel

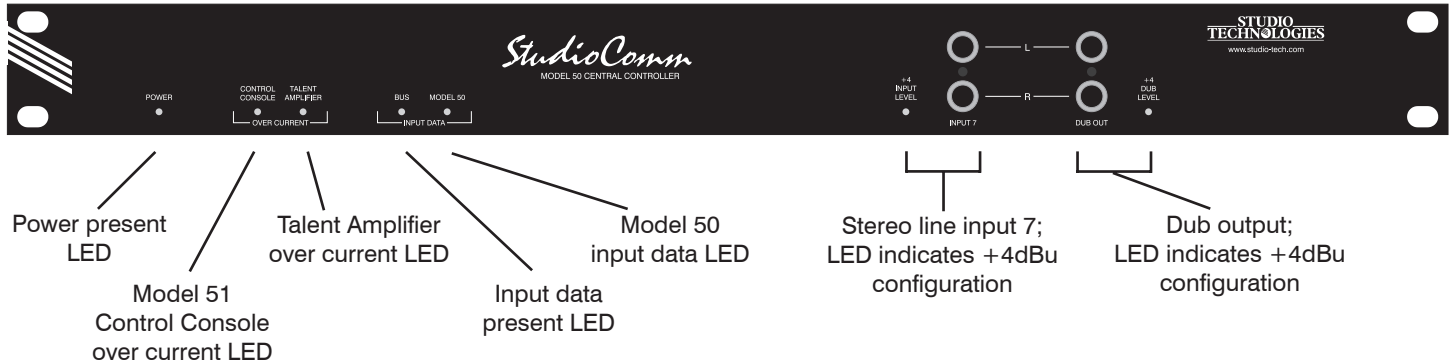

## Model 50 Back Panel

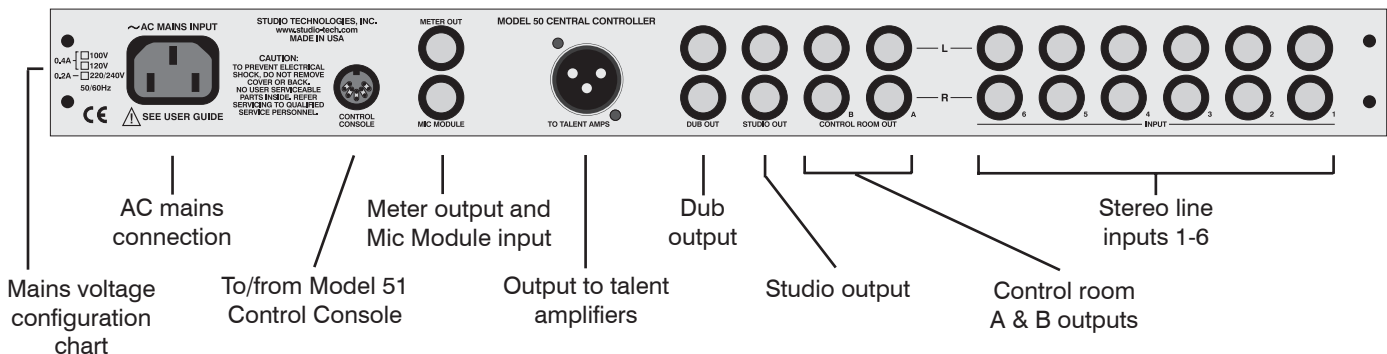



## **Studio Monitoring**

The studio monitoring source is configured to follow either the selected control room source or the headphone source. A push button, along with an associated LED, provides the studio on/off function. A rotary potentiometer is used to set the level.

## **Dub Output**

A stereo line-level output is provided as a dub (copy) output. Any of the seven inputs can be assigned to the dub output. The dub output can also be configured to follow the source selected for the control room output. The slate function allows communications (voice) audio to be sent out the dub output. For convenience, the dub output is available from both the front and back panels of the Model 50.

## **Communications Functions**

The Model 51 Control Console contains an internal microphone that is used in conjunction with the three communications functions. The talk to studio function interrupts the studio source and sends communications audio. The talk to phones function either interrupts the phones source or adds (sums or mixes) communications audio with the phones source. The slate function interrupts the dub source and connects communications audio. The slate function can be configured to send a 50Hz sine wave along with communications audio. The audio level of each communications function is individually adjustable.

## **MIDI Control**

All Model 50 Central Controller functions are controlled using system-exclusive MIDI messages. The Model 51 Control Console “speaks” this language, and in most

applications a Model 51 will be utilized. In special applications the Model 50 Central Controller can be connected directly to a MIDI bus, allowing the creation of a fully automated recording or audio routing system. (For more information on MIDI support, refer to Appendix A.)

## **Configuration**

The Model 51 Control Console can be configured to make the system meet a user’s exact operating environment. As previously discussed, each of the seven stereo line inputs can be independently set for  $-10\text{dBV}$  or  $+4\text{dBu}$  operating levels. They also can be set for either mono or stereo operation. In the mono mode a signal connected to the left input is sent to the left and right outputs. The dub output level can be set for a nominal  $-10\text{dBV}$  or  $+4\text{dBu}$  output level.

Unique to the system is the ability to configure the dim level to one of six values, ranging from full attenuation to a modest 10dB reduction. The auto dim off function, when configured, allows any change in the control room level potentiometer to automatically turn off an active dim state.

The talk to phones function can be configured to either interrupt the source selected for headphone audio and connect communications audio, or to have the communications audio added (summed or mixed) with the headphone audio.

The slate function can be configured to generate a 50Hz sine wave when activated. This provides an audible “marker” for analog tapes, and a visual indication on a wave form display screen.

Four functions can be set for push-to-latch operation if desired: talk to studio, talk to phones, slate, and control room mono.

**Model 51 Front Panel**

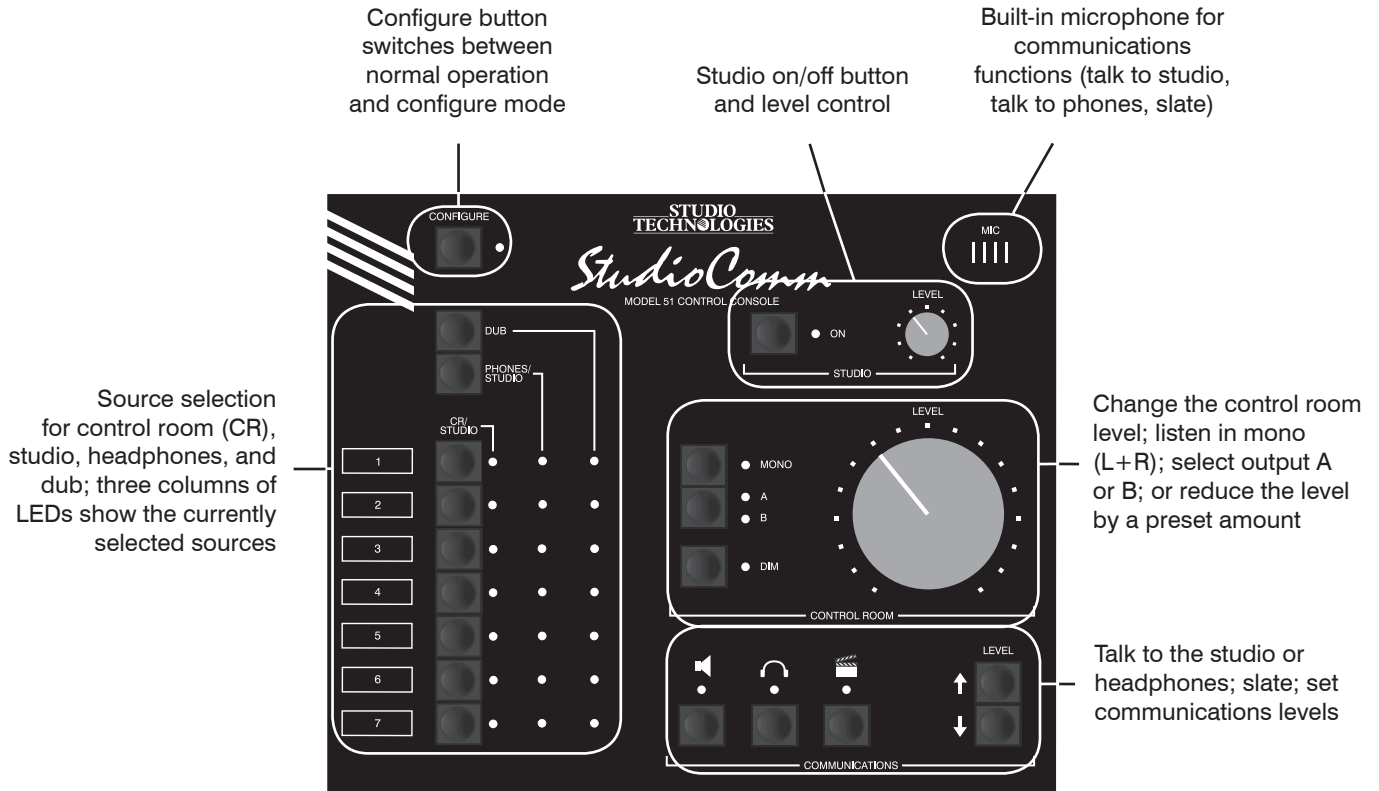

**Model 51 Back Panel**

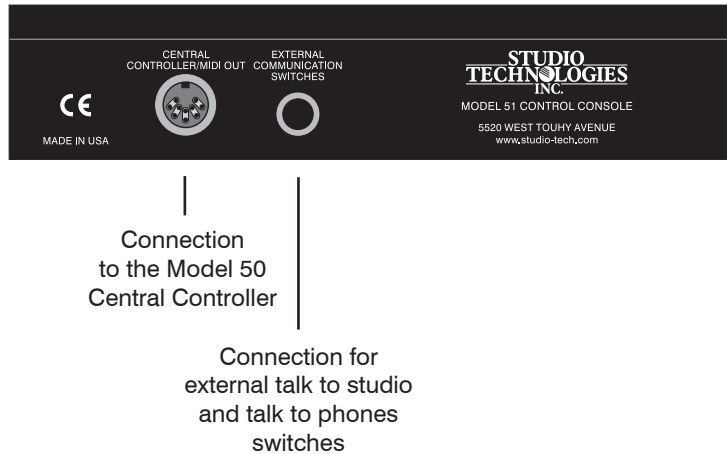

The studio output is set to follow the control room source or the headphone source. The headphone source is set for independent selection or to follow the control room source. The dub source is set for independent selection or to follow the control room source.

All configuration parameters, along with “power down” operation conditions, are stored in nonvolatile memory.

## Headphone Monitoring

The StudioComm system contains an integrated, full-featured headphone (cue) system. Up to four Model 35 or Model 38 Talent Amplifiers can be connected to the Model 50’s talent amplifier output. A single 3-conductor microphone-type cable carries power and stereo audio.

Using the Model 51 Control Console, any of the seven stereo inputs can be assigned to the talent amplifier output. The talk to phones function allows communications (voice) audio to be sent to the talent amps. The talent amplifier output is short circuit protected. Error conditions are displayed by the Talent Amplifier Over Current LED on the Model 50’s front panel.

Each Model 35 and Model 38 Talent Amplifier can drive two sets of high-impedance headphones ( $>150\Omega$ ). The audio output is loud, and very “clean.” The units feature a built-in level control, a stereo/mono switch, and a power present LED.

The Model 38 Talent Amplifier takes the basics from the Model 35 and adds a unique stereo preamplifier section. This

## Model 35 Front Panel

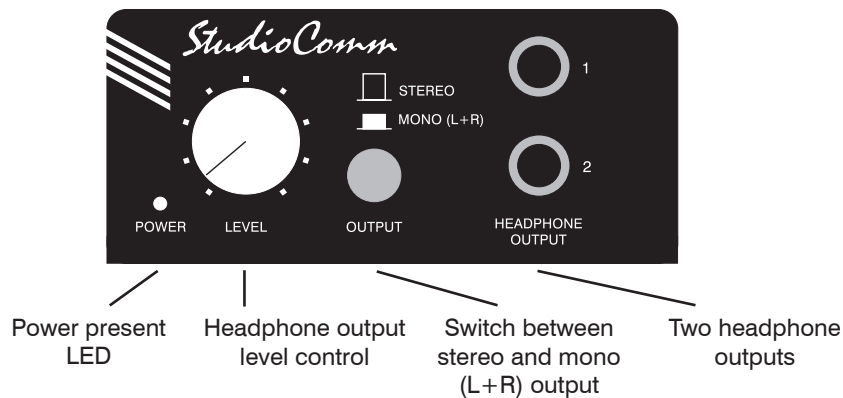

## Model 35 Back Panel

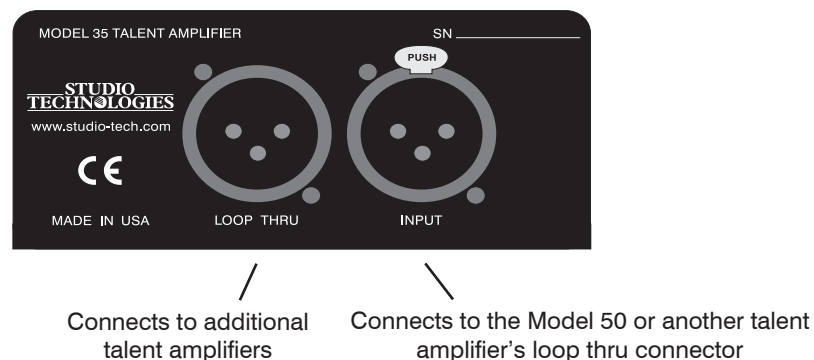

allows a musician's microphone or line-level signal to be "looped" through the Model 38, boosted by its preamp, and then combined with the stereo cue mix supplied by the Model 50. This provides each Model 38 with an individual headphone mix, solving the classic problem of wanting "more me" in the phones! Like the Model 35, the Model 38 is linked with a Model 50 Central Controller by a single cable.

## Installation

In this section you will be installing the Model 50 Central Controller in an equipment rack. Audio input and output connections will be made using the Model 50's multitude of 1/4-inch phone jacks. One or more Model 35 or Model 38 Talent Amplifiers will be connected. A location will be selected for the Model 51 Control Console, and it will be connected to the Model 50. AC mains power will be connected to the Model 50.

### Model 38 Front Panel

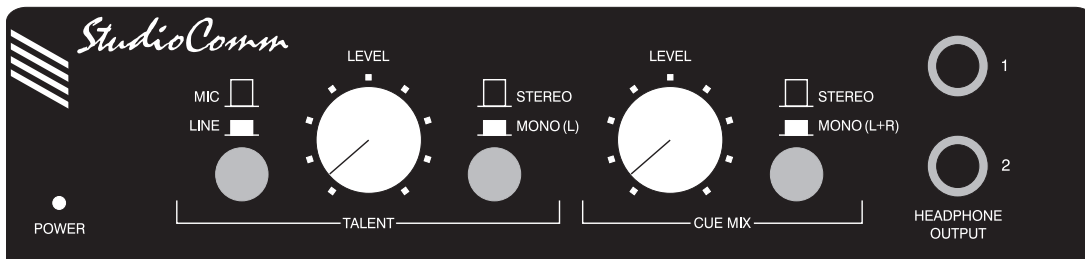

- Power present LED
- Mic/Line button switches the talent input between microphone and line level
- Talent level to phones
- Switch between stereo and mono (L only) for the talent input
- Cue mix level to phones
- Switch between stereo and mono (L+R) for the cue mix
- Two headphone outputs

### Model 38 Back Panel

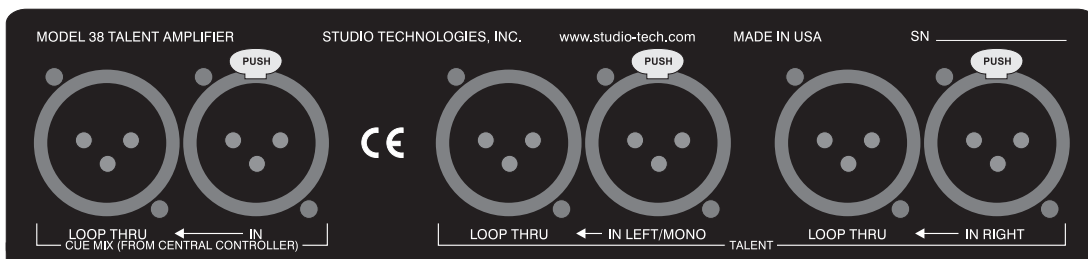

- Connects to additional talent amplifiers
- Connects to the Model 50 or another talent amplifier's loop thru connector
- Loop thru connectors parallel the talent inputs for routing to a digital audio workstation, effects device, microphone preamp, etc.
- Connects to talent sources such as keyboards or microphones

## System Components

The main StudioComm shipping carton contains a Model 50 Central Controller, Model 51 Control Console, 5-conductor MIDI-style cable, and User Guide. Units destined for North America are shipped with an AC mains cord. Your dealer or distributor will provide an AC mains cord for non-North American destinations. Model 35 and Model 38 Talent Amplifiers, along with accessories, will be contained in separate cartons. Please check to ensure you have everything you need.

## Mounting the Model 50

The Model 50 requires one space in a standard 19-inch (48.3cm) equipment rack. Select a location near where the Model 51 Control Console will be located. A cable is provided to connect the Model 50 to the Model 51. If required, you can supply a longer cable, however 50 feet (15.3m) is the recommended maximum length. It is desirable to locate the Model 50 to allow easy access to both the front and the back panels. The back panel contains most of the input and output connectors, while the front panel is used to access line input 7 and a multiple (mult) of the dub output. In addition, the front panel also contains several LED indicators. The Model 50 is secured to the equipment rack using two mounting screws per side.

## Audio Inputs and Outputs

The Model 50's line-level audio input and output connections are made using ¼-inch 3-conductor phone jacks. The choice of phone jacks was simply a matter of real estate—21 XLR connectors don't quite fit on the back of a one rack-space unit!

### Balanced Input and Output Connections

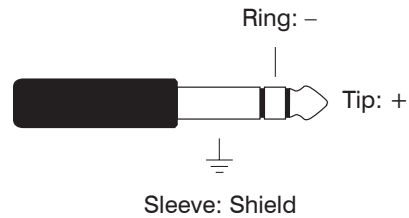

(Switchcraft No. 297, Neutrik NP3C, or equivalent)

### Unbalanced Input and Output Connections

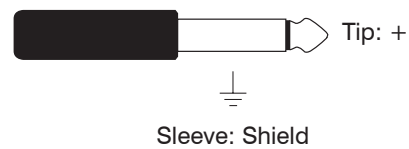

(Switchcraft No. 280, Neutrik NP2C, or equivalent)

For connection of balanced input and output signals, ¼-inch 3-conductor phone plugs should be used. The plugs should be wired with tip positive (+ or hot), ring negative (– or cold), and sleeve shield. With unbalanced input and output signals, either ¼-inch 2- or 3-conductor plugs can be used. With 2-conductor plugs tip should be wired as positive (+ or hot) and sleeve as shield. With 3-conductor plugs tip should be wired as positive (+ or hot) and both ring and sleeve as shield.

## Stereo Line Inputs

The Model 50 provides seven stereo line-level inputs. Inputs 1 through 6 are located on the back panel; input 7 is on the front. Each input is electronically balanced, and can be configured for compatibility with –10dBV or +4dBu signal levels. The Model 51 Control Console gives you push-button control, so you can easily change input sensitivities at any time (refer to the Configuration section under Input Sensitivity). Monaural sources

should be connected to the left (L) input and configured for mono operation (refer to the Configuration section under Stereo/Mono Input).

### **Control Room Outputs**

The Model 50 contains two stereo line-level outputs for connection to two audio power amplifiers. These audio amps serve two pairs of loudspeakers that are located in the control room. (Of course the control room outputs can be connected to loudspeakers that contain integral power amplifiers, such as the products from Genelec.)

The outputs, labeled A and B, are electronically balanced and capable of driving loads of 600 ohms or greater. In most situations best performance will be obtained if the audio amplifier's input sensitivity is set to near maximum. Refer to the Technical Notes section for details on setting amplifier sensitivity.

### **Studio Output**

The Model 50 contains a stereo line-level output for connection to an audio power amplifier. This audio amplifier serves the pair of loudspeakers that is located in the studio area. (Of course the studio output can be connected to loudspeakers that contain integral power amplifiers.)

The output is electronically balanced and capable of driving loads of 600 ohms or greater. In most situations best performance will be obtained if the audio amplifier's input sensitivity is set to near maximum. Refer to the Technical Notes section for details on setting amplifier sensitivity.

### **Dub Output**

The Model 50 contains a stereo line-level output which is intended for connection to a variety of analog audio devices. The dub output is electronically balanced and capable of driving 600 ohm loads or greater. With the input impedance of most audio devices at 10k ohms or greater, the dub output can easily drive 10 or more devices simultaneously. The dub output can be configured for a nominal level of  $-10\text{dBV}$  or  $+4\text{dBu}$ , so you can connect to all line-level inputs with no hassle (refer to the Configuration section under Dub Output Level).

The dub output is available on phone jacks located on both the front and back panels of the Model 50. The phone jacks are connected in parallel, being a multiple or mult of each other; one set of dub output circuits drive both outputs. The design intention was that permanent connections would be made to the back panel dub output, while the front panel dub output would remain available for "on the spot" use.

### **Meter Output**

The meter output is intended for connection to VU- or PPM-style meters or meter panels that contains input buffer circuitry or series current-limiting resistors. The meter output channels have a nominal level of  $+4\text{dBu}$ , but are not precisely calibrated by Model 50 circuitry. While 1%-tolerance resistors are used in the Model 50, the meters or meter panels should include calibration trim pots to ensure the most accurate level reading.

A single 1/4-inch 3-conductor jack is used to connect to the stereo meter output. Each output channel is unbalanced, has

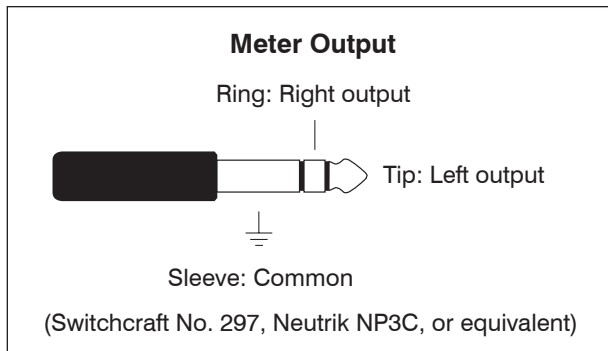

a nominal level of +4dBu, and is capable of driving loads of 2k ohms and greater. A 1/4-inch 3-conductor plug should be wired with tip for the left output, ring for the right output, and sleeve for common.

### Mic Module Input

A 1/4-inch 3-conductor phone jack, labeled Mic Module, is located on the back panel. In most cases the Mic Module input will not be used, and no plug should be inserted. For details on using the Mic Module input, refer to the Advanced Installation Topics section later in this guide.

### Talent Amplifier Output

Up to four Model 35 or Model 38 Talent Amplifiers can be connected in any combination to the Model 50's talent amplifier output. The output connector is a 3-pin male XLR-type. For best performance, use low-capacitance shielded microphone-type cable to distribute the talent amplifier signal. If you have a choice, select cables with the heaviest wire gauge commonly available. This will reduce voltage drop when using long cable runs. Refer to the Technical Notes section for additional information.

The simplest installation would use a microphone cable to connect the Model 50 to the first talent amplifier; the loop

through connector on that talent amp sending the signal on to the next talent amp.

For convenience, you may want to wire your facility to allow easy access to the talent amplifier signal at all locations where talent amplifiers might be used. The talent amplifiers connect to the Model 50 in parallel, so the connectors on the distribution panels or mult boxes must be wired in parallel.

**Warning:** Do not connect the Model 50's talent amplifier output to anything but Studio Technologies' talent amplifiers. Some audio equipment may be damaged by the +23Vdc contained on pin 2 of the talent amplifier output connector.

Several mounting options are available for the Model 35 and 38 Talent Amplifiers. For details refer to the Mounting Options sections in the Advanced Installation Topics section of this user guide.

In special cases you may need to obtain a stereo, balanced line level output signal from the Model 50 talent amplifier output. The Model 70 Interface is available for this purpose. For details refer to the Advanced Installation Topics section later in this guide.

### Locating the Model 51 Control Console

The Model 51 was designed for desktop use, however provision has also been made for microphone-stand mounting. For details refer to Mounting Options in this section.

### Connecting the Model 50 to the Model 51

A standard 5-conductor MIDI-style cable is used to connect the Model 50 to the Model 51; a cable is included with your system. Just connect the cable between

the female 5-pin DIN-type connectors on the back of the Model 50 and 51, and you're done.

**Note:** If you require a longer cable, be certain to buy a MIDI cable that has all five pins wired. If they aren't all connected, the Model 51 will not operate. This is because the Model 50 powers the Model 51 with the pins that aren't used for MIDI data.

For best performance, the cable that connects the Model 50 with the Model 51 should be limited to 50 feet (15.3m). Should you need to exceed this length, refer to the Technical Notes section of this guide for details on the cable requirements.

For more information on MIDI, and using controllers other than the Model 51, please refer to Appendix A.

### Remote Control Inputs

The Model 51 allows the connection of two external switches or contact closures. Refer to the Advanced Installation Topics section of this guide for details.

### AC Mains Power

The Model 50 is internally configured to operate from either 100, 120, or 220/240V, 50/60Hz. In most cases, units shipped to North America are factory selected for 120V operation. Units bound for Japan are selected for 100V, while our friends "down under" and in Europe receive units set for 220/240V. Before connecting the Model 50 to mains power, check that it is configured to match the local mains voltage. Look on the back panel, adjacent to the power entry connector, for the configured voltage(s). Note that an incorrect configuration could seriously damage the unit.

Should it be necessary to change the unit's operating voltage it must be performed only at the factory or by an authorized service technician.

The Model 50 uses an IEC standard connector to mate with the AC mains cord. The wire colors in the AC mains cord should conform to the internationally recognized CEE color code and must be wired accordingly:

<u>Connection</u>	<u>Wire Color</u>
Neutral (N)	Light Blue
Line (L)	Brown
Protective Earth (E)	Green/Yellow

**Safety Warning:** The Model 50 does not contain an AC mains disconnect switch. As such the mains cord plug serves as the disconnection device. Safety consideration requires that the plug and associated outlet be easily accessible to allow rapid disconnection of mains power should it prove necessary.

As soon as mains power is applied, the Model 50's power present LED will light. The Model 51 will go through its power-up sequence lighting each LED in a rapid sequence. The power present LEDs on the talent amplifiers will also light.

The two Over Current LEDs located on the front panel of the Model 50 should not be lit. If either or both are flashing, immediately refer to the Troubleshooting section of this guide. If everything appears to be functioning properly you are now ready to configure the system.



# Advanced Installation Topics

## Model 35 Stand Mounting

Included with each Model 35 Talent Amplifier is a nifty mounting adapter that allows the unit to be conveniently attached to a microphone stand. Please refer to the Installation Guide provided in the Model 35's shipping carton for details.

## Model 38 and Model 51 Mounting Options

The Model 38 Talent Amplifier and the Model 51 Control Console include provisions for mounting to microphone stands, equipment consoles, etc. To avoid "reinventing the wheel," our products are compatible with the 25 Series components from OmniMount Systems, a supplier of finely engineered mounting systems. This firm makes many versions of the 25 Series; one of which should fit your needs. If you desire microphone stand mounting the following components would be appropriate for English-thread applications: 25RST-25H Straight Tube Reverse Mount with Quick Release, along with a 25MA Microphone Stand Adapter. (If quick adjustment is not required the 25RST Straight Tube Reverse Mount can be used in place of the first item.) When connecting to metric-thread stands please contact OmniMount for the correct part numbers.

The bottom surface of the Model 38 Talent Amplifier contains two threaded inserts that will accept English-standard 1/4-20 screws. Using two, 5/8-inch long, round-head machine screws, the 25 Series clamp assembly can be directly attached. The cover of the Model 38 does not have to be removed.

The design of the Model 51 did not allow the inclusion of threaded inserts, so holes of adequate size to allow 1/4-20 round head machine screws are provided. It is intended that screws of 5/8-inch length, along with lock washers and machine nuts, will securely attach a 25 Series mounting clamp assembly. The cover of the Model 51 will have to be removed to gain access to mounting holes. Be careful when selecting the mounting screws—exceeding the recommended 5/8-inch length will cause the mounting screws to damage the Model 51's internal components.

## Remote Control Inputs

The Model 51 allows you to connect two external switches or contact closures to enable system functions. Input 1 allows either a remote talk to studio or a remote control room source select function to be implemented. Input 2 allows a remote talk to phones function to be implemented. Using the remote "talk to" functions, it may be useful to install switches at a producer or director location. The Model 51 continues to provide local talk to studio and talk to phones access even when external switches are connected.

The required connector is a 1/4-inch 3-conductor phone plug. Tip is talk to studio or control room source select, ring is talk to phones, and sleeve is common.

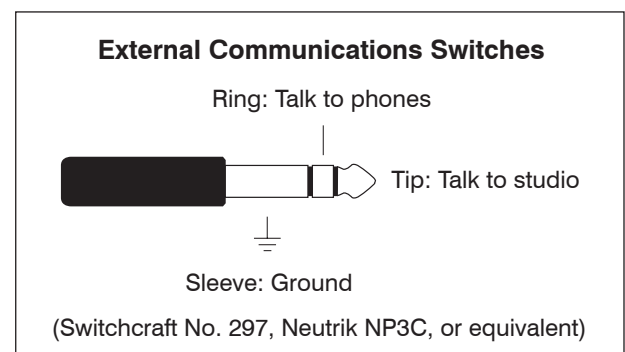

Switchcraft No. 297, Neutrik NP3C, or equivalent will work correctly. Use a momentary, single-pole, single-throw switch for each remote function. The respective function is activated when the tip or ring get shorted to the sleeve.

While the Model 51's talk to studio and talk to phones buttons can be configured to latch, the remote control inputs are always push to activate. This is provided as a safety feature preventing an external user from "latching" one of the functions to the on state.

### Mic Module Input

The Model 51 Control Console contains a microphone which provides the audio source for the Model 50's communications functions. In special applications the Model 51 may not be used, and a separate source of communications audio will be necessary. The Mic Module input on the back panel of the Model 50 allows this to be easily accomplished.

Even if you are using the Model 51 Control Console you may want to provide an alternate source of communications audio. To use your own microphone and preamp, directly connect it using the Mic Module input jack. The Mic Module input is a 1/4-inch 3-conductor phone jack with +12Vdc on tip, audio input on ring, and

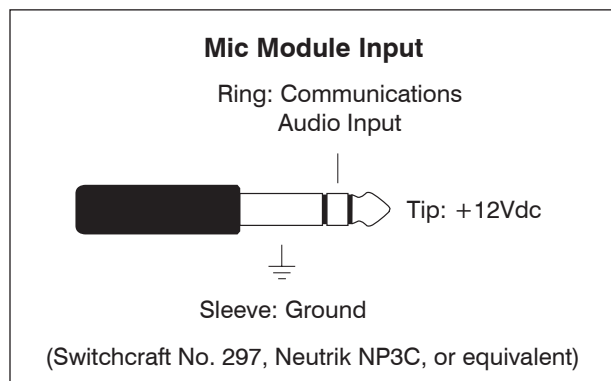

ground on sleeve. The audio input requires a nominal -10dBu signal (-10dBu, not -10dBV!). The +12Vdc on the tip is from the same source that powers the Model 51, and is provided to power an external preamp. If you feel the urge to use this power source, be aware that it only provides 110 milliamps of current of which the Model 51 needs about 100mA. So go ahead and use all the current you need, as long as it doesn't exceed 10mA!

**Note:** Communications audio from the Model 51 is routed into the Model 50's circuitry through the normal connection on the ring contact of the Mic Module input jack. When a phone plug is inserted into the Mic Module input, the audio path from the Model 51 to the Model 50 is broken. This means you can't use the Model 51's microphone and the Mic Module input at the same time.

### Model 70 Interface

In most cases Model 35 and/or Model 38 Talents Amplifiers will be used to drive headphones associated with a StudioComm installation. In special cases a line level signal may be required to interface the Model 50 Central Controller's talent amplifier output with other audio equipment. An example would be to use the Model 50 with an existing headphone system. The Model 70 Interface is used to convert the talent amplifier signal to a stereo, balanced line level signal.

Installation is very simple. Connect the Model 70 to the Model 50 Central Controller's talent amplifier output using a standard 3-conductor microphone-type cable. For best performance, use low-capacitance shielded cable.

The Model 70 provides independent left and right balanced outputs. Pin 1 is shield, pin 2 is signal positive (+ or hot), and pin 3 is signal negative (– or cold). The electronically balanced outputs have a nominal signal level of +4dBu and are capable of driving loads of 600 ohms or greater.

The Model 70 can be used by itself, or in conjunction with up to four Model 35 or Model 38 Talent Amplifiers. The loop through connector on the Model 70 can be used to connect to a Model 35 or 38 Talent Amplifier.

## Configuration

Many StudioComm functions can be configured to meet the exact needs of your installation. Here's an overview of what you can configure:

- –10dBV or +4dBu level for each input
- Stereo or mono for each input
- –10dBV or +4dBu level for the dub output
- Dim level
- Auto dim off function
- Studio source follows control room or headphone source

### Model 70 Front Panel

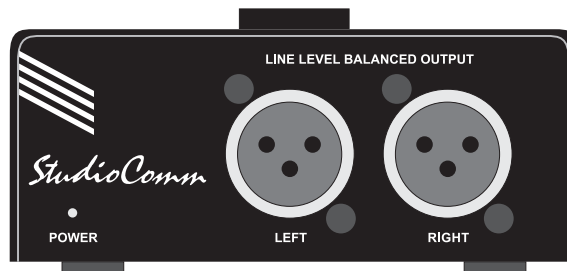

### Model 70 Back Panel

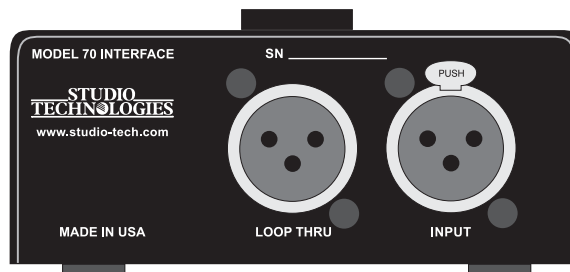

- Headphone source is independently selected or follows control room source
- Momentary or latching operation for mono, talk to studio, talk to phones, and slate buttons
- Talk to phones interrupts or adds to phones source
- 50Hz slate tone on or off
- Dub source is independently selected or follows control room source
- Remote control room source select parameters
- Level control auto mute

The Configure button allows the Model 51 to go into the configure mode. While in the configure mode, all the Model 51's buttons and LEDs are associated with configure functions. Refer to the Model 51 Configuration Chart later in this section.

To enter the configure mode, press and hold the Configure button for two seconds. While in the configure mode, all audio outputs switch off and the orange LED beside the Configure button will flash. As you make changes, the Model 51 keeps track of the new settings and updates the system when you exit the configure mode. You must exit the configure mode before any changes take effect.

### **Input Sensitivity**

The CR/Studio column of seven red LEDs shows you whether an input is set to be compatible with  $-10\text{dBV}$  or  $+4\text{dBu}$  signal levels. When a red LED in the CR/Studio column is off, it means the input is set to  $-10\text{dBV}$ . When lit, the corresponding input is set to  $+4\text{dBu}$ . Just press the CR/Studio buttons to toggle inputs 1 through 7 between  $-10\text{dBV}$  and  $+4\text{dBu}$ .

For convenience, Input 7 is located on the front panel of the Model 50. It has a green LED beside it labeled  $+4$  Input Level. When lit, it tells you that Input 7 is set for  $+4\text{dBu}$ . This means each time you connect a new signal to Input 7, you don't have to go into the configure mode to determine the input sensitivity. You should note, however, that configure settings aren't updated until you leave the configure mode, so the  $+4$  Input Level LED won't reflect a change until you exit.

### **Stereo/Mono Input**

The Phones/Studio column of seven green LEDs indicates whether an input is configured for mono or stereo operation. When an LED in this column is off, the input is set for stereo; the LED on means the corresponding input is set for mono. In mono mode, the left input is sent out both the left and right outputs. To toggle a channel between stereo and mono, press and hold the Phones/Studio button and press the CR/Studio buttons that correspond to inputs 1 through 7. After you leave the configure mode, inputs configured for a mono source will flash during normal operation.

### **Dub Output Level**

The Dub column of orange LEDs will help you configure two options: dub output level and dim level. The orange LED in the first row (number 1 at the top) tells you whether the dub output is set to  $-10\text{dBV}$  or  $+4\text{dBu}$ . When the LED is off, the dub output is set to  $-10\text{dBV}$ ; when it's on, the dub output is configured for  $+4\text{dBu}$ . The dub output on the front panel is in parallel with the dub output on the back panel, so one configure setting controls both. For convenience, a green LED on the front panel is provided that lights when the dub output level is set to  $+4\text{dBu}$ . This means

you don't have to use the configure mode to determine the dub output level. And just like the +4 Input Level LED for Input 7, the +4 Dub Level LED does not reflect a change until you exit the configure mode.

### **Dim Level**

The dim function is used to reduce the control room output level a preset amount whenever you press the Dim button. You can take a quick phone call without using the level control to change the control room level. Also, any time you press the talk to studio, talk to phones, or slate buttons the dim function is activated.

In the configure mode, LEDs 2 through 7 in the Dub column indicate the selected dim level. Dim can only have a single setting, so only one of the orange LEDs is on at a time.

<u>Row Number</u>	<u>Dim Value (dB)</u>
2	Max. attenuation (approx. 72dB)
3	30
4	25
5	20
6	15
7	10

When the orange LED is on in row two, dim will cause an approximately full mute (no output). Dim is down 30dB in row three, 25dB in row four, and so forth. To change the dim level, hold down the Dub button while pressing the CR/Studio button of your choice.

### **Studio Source Selection**

For space considerations, a separate push button and column of LEDs is not provided for studio source selection. The Model 51 is configured for either the studio source to follow the control room

source, or the studio source to follow the headphone source.

In configure mode, the red Studio On LED tells you which function the studio source will follow. When the LED is off, the studio will follow the control room source; when it's on, the studio will follow the headphone source. Press the Studio On button to toggle the setting.

### **Mono Function**

The Mono function allows the control room output to be placed in the mono (L+R) mode. When you're in configure mode, the red LED labeled Mono tells you whether the Mono button works as a momentary or latching button. When the button is set to momentary, the LED will be off and mono mode will only be active while you press and hold the Mono button. When the LED is on, the button is set to latch. With this setting, you can press the Mono button once and it will remain in mono mode until you press it again.

### **Auto Dim Off**

The auto dim off function is unique to StudioComm products, making the dim function respond to real world operating conditions. When enabled, the function automatically turns the dim function off if a change is made to the control room level potentiometer while the unit is already in dim mode. This prevents a heart-stopping blast of audio when an engineer presses the dim button to turn dim on, but actually turns it off because the unit was already in the dim mode. While it's hard to explain unless you've used a console and experienced this in person, trust us, this situation does happen! Auto dim off is a wonderful "real-world" function and in most cases should be configured.

## Model 51 Configuration Chart—Main Functions

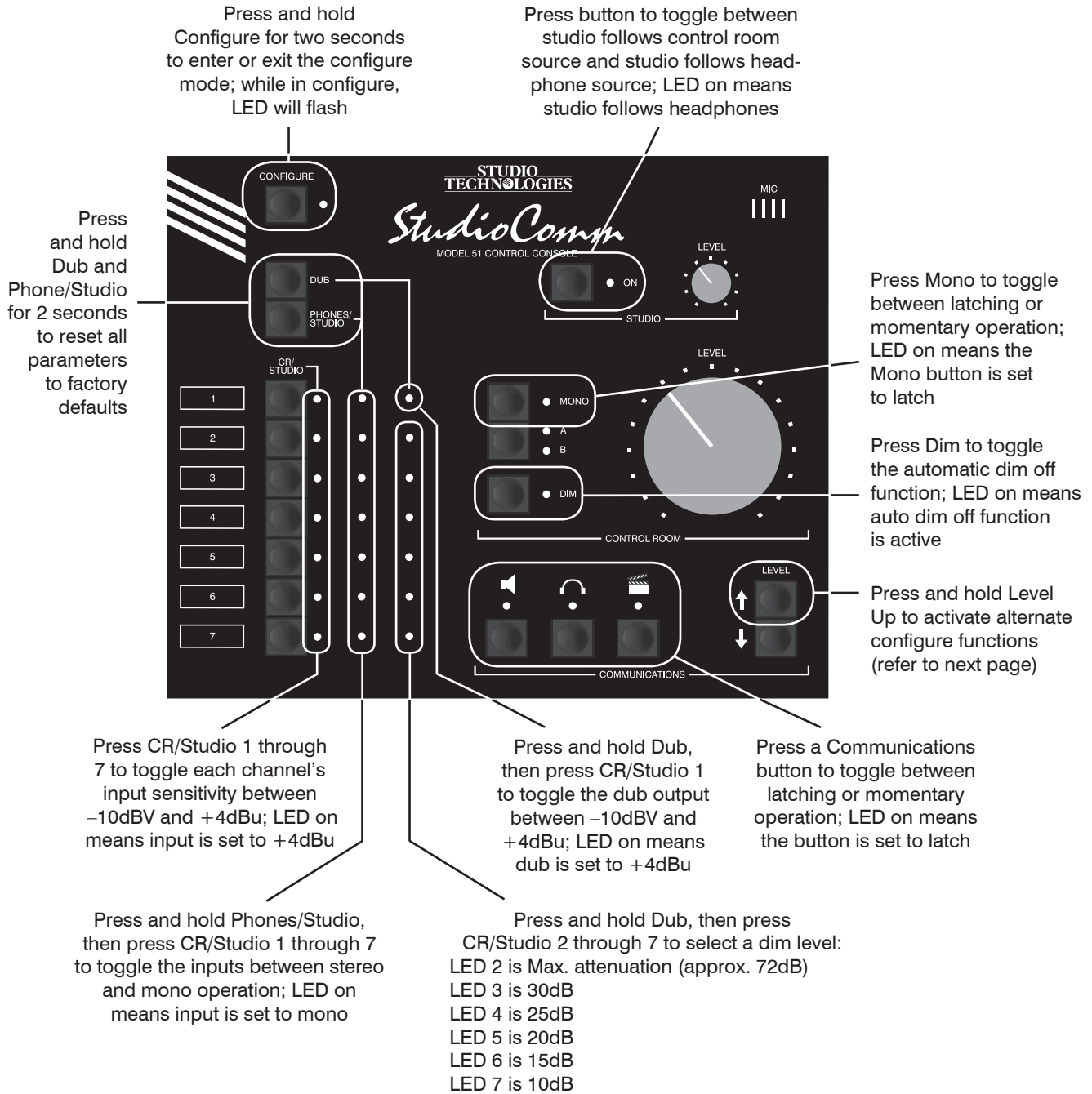

## Model 51 Configuration Chart—Alternate Functions

Press and hold Phones/Studio, then press CR/Studio 1 to toggle between normal headphone source and headphones follow control room source; LED on means headphones follow control room

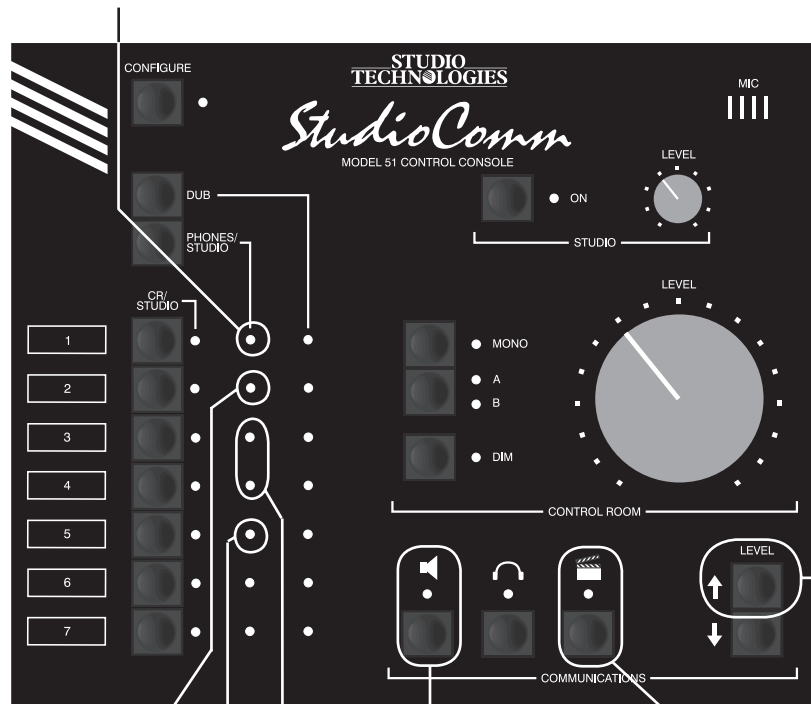

Press and hold Level Up to activate alternate configure functions

Press and hold Phones/Studio, then press CR/Studio 2 to toggle between normal dub source and dub follows control room source; LED on means dub follows control room

Press Talk to Studio to toggle phones interrupt and phones add; LED on means talk to phones is add

Press Slate to toggle to 50Hz slate tone; LED on means 50Hz tone is on

Press and hold Phones/Studio, then press CR/Studio 5 to toggle the state of the level control auto mute function; when the LED is lit the function is enabled

Press and hold Phones/Studio, then press CR/Studio 3 to configure remote control room source select; LED on means function enabled

Press and hold Phones/Studio, then press CR/Studio 4 to configure channel associated with remote control room source select; LED off means channel 6 selected; LED on means channel 7

In the configure mode the Dim LED tells you if auto dim off is enabled. When the dim LED is off, the auto dim off function is off; when the Dim LED is lit, the auto dim off function is on.

### **Communications Functions**

There are three Communications buttons at the bottom center of the Model 51. Moving from left to right, the buttons are talk to studio, talk to headphones, and slate. During configuration, LEDs above the Communications buttons tell you whether the buttons will latch when you press them. When an LED is off, the button below it won't latch. You would have to press and hold the button to activate the function. When an LED is on, it indicates that the button will latch. Pressing the button will activate the function until it's pressed again.

Note that the Model 51's external communications switch inputs are always configured for momentary operation. They cannot be set for push-to-latch operation.

### **Reset Factory Defaults**

Provision has been made to allow you to return all configurable parameters to the factory default values. With the Model 51 in the configure mode, press and hold both the Dub and Phones/Studio buttons. After two seconds the factory defaults will be stored in memory, the configure mode will automatically end, and the Model 51 will return to normal operation.

### **Alternate Configure Functions**

To allow additional functions to be configured, an alternate configure mode is utilized. By pressing and holding the Level Up button the alternate functions are accessed. This is like the ALT key on your personal-computer keyboard.

### **Talk to Phones Interrupt or Add**

The talk to phones function can be configured to either interrupt the source selected for phones audio and connect communications audio, or to have the communications audio added (summed or mixed) with the phones audio.

While holding Level Up, the talk to studio LED is used to display whether talk to phones will interrupt the phones source, or add to the phones source. When the LED is off, the selected phones source will be interrupted and the communications audio source will be connected; when the LED is on the communications audio source will be added (mixed) with the phones audio source. While holding Level Up, press the button below the LED to toggle the setting.

### **50Hz Slate Tone**

A 50Hz slate tone can be generated whenever slate is active. While holding Level Up, the Slate LED is used to display whether the 50Hz tone is selected. When the LED is off, the 50Hz slate tone is off; when the LED is on, the slate tone is active whenever slate is active. While holding Level Up, press the button below the LED to toggle the setting.

### **Headphone Source Selection**

The default configuration makes the selection of the headphone source independent of the control room or dub selections. While this is most flexible there are operating scenarios where it would be convenient for the headphone source to follow whatever is selected for the control room source.

While holding Level Up, the first (top) LED associated with the Phones/Studio column



of LEDs displays the headphone source mode. When the LED is off the headphone source is selected independently of the control room source. When the LED is lit the headphone source follows the control room source. To make a change you hold Level Up, hold the Phones/Studio button and press the input 1 button. If you can make this change using only one hand, pat yourself on the back with the other one!

### **Level Control Auto Mute**

The level control auto mute function automatically mutes the monitor output channels whenever the rotary level control knob is in its fully counterclockwise position. In some applications it may be desirable to enable this function. When disabled, the rotary level control adjusts the monitor output level over an approximately 72dB range; no automatic muting takes place.

### **Dub Source Selection**

The default configuration makes the selection of the dub source independent of the control room or headphone selections. While this most flexible there are operational scenarios where it would be convenient for the dub source to follow whatever is selected for the control room source.

While holding Level Up, the second LED associated with the Phones/Studio column of LEDs displays the dub source mode. When the LED is off the dub source is selected independently of the control room source. When the LED is lit the dub source follows the control room source. To make a change you hold Level Up, hold the Phones/Studio button and press the CR/Studio button 2.

### **Remote Control Room Source Select**

The Remote Control Room Source Select function allows a contact closure to automatically select input 6 or 7 as the control room source. The remote control input connection that is, by default, associated with the remote talk to studio function is used to activate Remote Control Room Source Select.

While holding Level Up, the third and four LEDs associated with the Phones/Studio column of LEDs display the status of the Remote Control Room Source Select function. When the third LED is off the function is not active. When the third LED is on the function is active. The fourth LED displays the input channel associated with the function. When the LED is off channel 6 is selected. When the LED is on channel 7 is selected.

## **Operation**

Now that you've installed and configured the system, you're ready to go. You should find operation very easy.

### **Model 50 Central Controller**

The Model 50 front panel contains seven LEDs, one stereo line input, and one stereo line output.

The power present LED should be lit whenever AC mains power is connected. During normal operation the two Over Current LEDs will not be lit. They will flash only if there is a problem interfacing with the Model 51 Control Console or the talent amplifiers that you have connected. Refer to Troubleshooting section if either Over Current LED lights.

When used with the Model 51 Control Console, both Input Data LEDs will light whenever a message is received. Why are there two LEDs? They are provided for diagnostic use in those special cases where the Model 51 is not used, and another source is providing the messages. The Bus LED lights whenever any data is received, whether the messages are intended for the Model 50 or not. The Model 50 Input Data LED will light only when a MIDI-exclusive message that matches the Model 50's format is received. Refer to the Troubleshooting section if neither LED flashes during operation with the Model 51 Control Console.

Input 7 is located on the front panel for easy access; connecting a temporary source to your system doesn't require getting at the back of the Model 50. The LED associated with input 7 will light whenever the input is configured for +4dBu operation. If you require a change in input level refer to the Configuration section for details.

Again as a convenience function, dub output is available on the front panel. The LED associated with the dub output is lit whenever the output is set for +4dBu operation. Refer to the Configuration section if you require a change in dub configuration.

## **Model 51 Control Console**

All StudioComm functions are controlled using the Model 51 Control Console. To make things easy, we've divided the StudioComm functions into four main groups: input-output selection, control room outputs, studio output, and communications functions.

### **Input-Output Selection**

Input-output selection is simple. To select an input for monitoring in the control room, press one of the seven CR/Studio buttons.

The corresponding LED in the CR/Studio column will light to let you know which input is selected. If the input is set for mono the LED will continually flash on and off as a warning.

If the remote control room source select function is enabled, the select button associated with either input 6 or input 7 will not be usable. A remote signal will cause this input to be selected. Whenever the remote signal is activated, the control room source will automatically change to the designated input (6 or 7). When the remote signal is no longer active, the control room input source will return to the previous selection.

The source selected for control room monitoring will automatically be connected to the meter output. There is no independent selection of the meter output.

If the studio source is configured to follow the control room source, it will automatically switch to the input you select. You can easily tell if the studio is following the control room because whenever the studio output is on, the studio On LED will flash each time you select a new input.

Selection of the headphone source depends on how the Model 51 has been configured. In the default operating mode, to select an input for the headphones, press and hold the Phones/Studio button and press one of the seven CR/Studio buttons. In the Phones/Studio column, the LED for the input you select will light. If the input is set for mono the LED will continually flash on and off as a warning. If the studio source is configured to follow the headphone source, the studio source will automatically switch to the same input, and, whenever the studio output is on, the studio On LED will flash once.

If the headphone source has been configured to follow the control room source, each time one of the CR/Studio buttons is pressed, the headphone source will follow. You may still independently change the headphone source by pressing the Phones/Studio button and pressing one of the seven CR/Studio buttons. However, the headphone source will still follow any changes made to the control room source. If the studio source is configured to follow the headphone source it will continue to do so, even if the headphones are following the control room; whatever source is active for the headphones will be active for the studio.

A special function allows you to select no input to be sent to the headphones. This ensures a quiet feed to the phones, but still allows the talk to phones communications function to be used. To select no input, simply press and hold the Phones/Studio button, then press both Communications Level buttons at the same time. The Level buttons are located to the right of the three Communications buttons. All LEDs in the Phones/Studio column will be off when no input is selected. To again select one of the seven inputs, press and hold the Phones/Studio button, then press one of the seven CR/Studio buttons.

Selection of the dub source depends on how the Model 51 has been configured. In the default operating mode, to select an input for dub output, press and hold the Dub button and press one of the seven CR/Studio buttons. The appropriate LED in the Dub column will light. If the input is set for mono the LED will continually flash on and off as a warning. You can select no input just as you did for the headphones. Press and hold the Dub button, then press both Level buttons at the same time.

If the dub source has been configured to follow the control room source, each time one of the CR/Studio buttons is pressed, the dub source will follow. In this mode, the Dub button is no longer active.

### **Control Room Outputs**

Associated with the control room outputs are three buttons and one level control. In addition, the Communications Level buttons are used.

Use the Control Room Level knob to set the control room output level. By default, the knob adjusts the monitor output level over approximately 72dB of range. When the knob is in its fully counterclockwise position, low level audio signals will be present on the monitor outputs.

A Model 51 configuration parameter allows the level knob's automatic mute function to be enabled. When this mode is enabled and the knob is set to its fully counterclockwise position, the selected control room output automatically mutes. This feature is provided for those users accustomed to having a completely quiet output when the level knob is set to its minimum position.

The A/B button switches between the control room A and B outputs. If you only have only one set of control room monitors, be sure the proper LED is on.

The Dim button lets you lower the control room level by a fixed amount. The amount of attenuation depends on the dim level set in the configure mode (refer to the Configuration section for help). If the Dim LED is on and dim is configured to fully mute, there will be no control room output. The Dim button is always set to latch the function on or off.

If the auto dim off function is enabled, whenever dim is on and the control room level is changed, dim will automatically return to the off state. Note that the auto dim off function is not active whenever dim is on due to one of the communications functions being active.

The Mono button lets you send L+R to both the left and right control room outputs, as well as the meter output. The Mono button can be configured for momentary or latching operation.

For diagnostic purposes the control room left-only or right-only mode can be activated. To enter the mode you'll use the Communications Level buttons. Press and hold both Level buttons for about two seconds. The control room will switch from stereo operation to the left-channel-only mode. Press and hold the Level buttons again, and the control room switches to right channel only. Press and hold the Level buttons a third time and the control room switches back to stereo operation. The Level buttons continue to cycle through left, right, and stereo monitoring as you press them. You can even switch between the control room A and B outputs at any time during single-channel operation.

The control room A/B output LEDs indicate when you are in left-only or right-only modes. During normal operation either the A or B LED is lit steadily. During left-only operation the LED will flash once; in right-only operation the LED will flash twice.

### **Studio Output**

Associated with the studio output is one button and one level control. As you'd expect, use the level control to set the studio output level. The button is used to turn the studio output on or off. When the LED is

off, the feed to the studio is off. When the LED beside the button is lit, the feed to the studio is on. Note that the talk to studio communications function is active whether the studio output is on or off. As previously discussed, when the studio output is on the LED will flash each time a new studio source is selected.

### **Communications Functions**

Five buttons are associated with the communications functions. The three main buttons are called talk to studio, talk to phones, and slate. They have symbols that represent (from left to right) a loudspeaker, a pair of headphones, and a slate board (or "clapper"). Pressing each button activates the Model 51's built-in microphone and sends its audio to the respective output. Press the far left button (under the loudspeaker symbol) when you want to talk to the studio; press the button under the headphone symbol to talk to the headphones; and press the button under the clapper to slate. Remember that during a slate, microphone audio goes to the dub output. When you press one of the communications buttons, the LED above it will come on to tell you the function is active. Note that all three of the communications functions can be active at a time.

When you press the communications buttons, various things happen depending on the Model 51's configuration. For example, pressing the slate button may also generate a 50Hz tone on the dub output. Any of these buttons may be configured to stay on (latch) when you press them.

The talk to phones function is configured to interrupt or to add to the selected headphone source. If interrupt is selected, activating talk to phones disconnects the selected headphone source and connects communications audio. If add is selected, activating talk to phones leaves the headphone source connected and adds (sums or mixes) the communications audio.

You can independently set the output level for the three communications functions. To set the communications levels, press and hold any one of the three buttons and press the Communications Level buttons. (If the talk to studio, talk to phones, or slate buttons are set to latch, you won't have to hold them.) The LEDs above the buttons will flash each time the level is increased or decreased until you reach the top or bottom of the range. At this point, if you continue to press the Level button, the LED won't flash, indicating you're at the top or bottom of the eight-step level range. Note that the 50Hz tone will always be 10dB below the slate level.

Note that whenever the talk to headphones button is pressed its level is always selected, even if either or both of the other talkback buttons are also pressed. The talkback to headphones level always takes priority. If the talk to studio and slate buttons are pressed at the same time, the talk to studio level will have priority.

### **Headphone Level**

The headphone output level is adjusted directly at the Model 35 and/or Model 38 Talent Amplifiers. There is no headphone level adjustment available on the Model 51.

### **Configure Mode**

Refer to the Configuration section for an understanding of how to use the Configure button.

## **Talent Amplifiers**

**Warning:** Protect your ears! The StudioComm talent amplifiers are capable of driving headphones to extremely high sound pressure levels. Hearing experts advise against continuous extended play, especially at high levels.

### **Model 35 Talent Amplifier**

The power present LED should be lit whenever the Model 35 is connected to an operating Model 50. The Model 35 has a Level control and a Stereo/Mono button. You can plug in one or two pairs of headphones with a total impedance of 75 ohms or greater. Turn the knob to the output level you want and select stereo or mono by pressing the button. Both headphone outputs are controlled by the one level control. The Mono button sends L+R to both the left and right output.

### **Model 38 Talent Amplifier**

The Model 38 has the unique ability to provide a personalized headphone mix for the in-studio talent. The performer's audio can be connected to the talent inputs and passively looped through to the control room. This lets performers increase their level in the headphone mix without an engineer getting involved. The Model 38's circuitry was carefully designed to not interfere with the talent audio as it passes through.

The Model 38 has all the functions of the Model 35, plus it provides personal mix controls. The power present LED should

be lit whenever the Model 38 is connected to an operating Model 50. You can plug in one or two pairs of headphones with a total impedance of 75 ohms or greater. The Cue Mix Level control sets the headphone output level for the signal coming from the Model 50. The Cue Mix Stereo/Mono button switches both headphone outputs between a stereo and mono (L+R) feed of the cue mix.

The Model 38 allows connection of a Stereo or Mono talent signal at microphone or line level. If your talent source is stereo, connect it to the In Left/Mono and In Right connectors and set the Talent Stereo/Mono button for stereo operation. With a mono source, use only the In Left/Mono connector and set the Stereo/Mono button for mono operation. This will feed the mono talent source to both left and right headphone channels. Connect loop through cables as needed for feeds to the control room.

The Talent Mic/Line button is used to select an input sensitivity level for the talent source. When you connect a microphone or direct box, select Mic. When keyboards or other preamplified sources are connected, select Line. The expected signal level in the Mic position is -40 to -60dBu. In the Line position it's -10 to +10dBu. If you are unsure of your signal level, start with input sensitivity set for Line. If the output level is not sufficient, turn down the level control, switch to Mic, then listen as again you raise the level control.

The Talent Level control works just like you would guess: turn it up for more talent signal in the headphone mix, and turn it down for less. The Talent and Cue Mix level controls work like a mixer for the headphone outputs, so you can have

any level you want of either source in the headphone mix.

## Troubleshooting

If you're having problems getting the StudioComm system up and running, this section can help. If you haven't read the other sections of this guide, you should do so before proceeding.

### If the Model 51 Doesn't Work At All

Your StudioComm system was supplied with a 5-conductor DIN-type cable that is used to connect the Model 51 Control Console to the Model 50 Central Controller. This cable has an important characteristic; it implements all five conductors. This means that all five pins on each plug connect to each other using a length of 5-conductor cable. If you choose to use your own cable it's easy to get in trouble; many MIDI cables only have three conductors! You **must** use a 5-conductor MIDI-style cable or the Model 51 will not power up and function. Five conductor MIDI cables are not hard to find, but you must ask for them and ensure that you get what you asked for. **Be warned!**

### Talent Amplifier Over Current LED

During normal operation the talent amplifier Over Current LED should not light. It will flash on and off if the talent amplifier output is loaded to exceed its maximum output current. The most common reason for an over current condition would be a shorted interconnecting cable. Also, connecting more than the specified maximum of four Model 35 or Model 38 Talent Amplifiers can also cause the LED to light. Possible, but not likely, would be a fault condition in a Model 35 or Model 38.

If the LED does light, troubleshooting should prove quite simple. Begin by disconnecting the cable that is plugged into the talent amplifier output connector. Perform the disconnection directly on the Model 50's back panel. The LED should stop lighting. Now check through all the wiring to determine where the short circuit condition is located. The Model 50 will not be damaged if the Over Current LED is lighting so you should use it to help you locate the fault in your system. In just a few minutes you should be able to isolate exactly what cable or talent amplifier is causing the problem.

### **Control Console Over Current LED**

During normal operation the control console Over Current LED should not be lit. It will flash on and off if the power source that supplies the Model 51 Control Console is loaded to exceed its maximum output current. The most common reason for an over current condition would be a shorted 5-conductor MIDI-style interconnecting cable. A major fault in the Model 51 would also cause the LED to light.

If the LED does light, you should find troubleshooting very easy. Begin by disconnecting the cable that is plugged into the Control Console/MIDI In connector on the Model 50's back panel. The LED should stop lighting. Reconnect the cable to the Model 50 and disconnect the cable's other end from the Model 51. If the LED still lights you have a bad cable. If the LED does not light there is a problem with the Model 51. Replace the cable if it proves to be bad—remember you'll need a MIDI-style cable with all five conductors connected. If the Model 51 appears to be at fault it will need to be returned to the factory for repair.

### **Input Data LEDs**

The Model 50 Central Controller's front panel contains two LEDs that represent incoming data. The Bus LED lights any time valid MIDI-compatible data enters the unit. The Model 50 LED lights only when data is received that is valid for the Model 50. The Model 50 uses MIDI system-exclusive messages to perform all operations. When the Model 51 Control Console is connected to the Model 50, both data LEDs will light any time the Model 51 generates data. This is because the Model 51 will only generate data that is compatible with the Model 50.

If you are not using the Model 51, and instead are supplying MIDI data using another device, the LEDs should prove extremely useful when troubleshooting. Once the Model 50 is connected to a data bus that is carrying MIDI data, the Bus LED will light whenever **any** MIDI data is received. Only when the MIDI data conforms to the Model 50's MIDI system-exclusive format will both the data LED's light. If the Bus LED lights, but the Model 50 LED does not, this indicates that the data is not configured correctly for the Model 50. Refer to Appendix A, located at the end of this guide, for details on how data must be sent to the Model 50.

### **Clicks in the Audio**

As covered in the Configuration section of the guide, the seven stereo line inputs can be configured for  $-10\text{dBV}$  or  $+4\text{dBu}$  operation. Setting an input for  $-10\text{dBV}$ , while connecting an audio source with a  $+4\text{dBu}$  nominal level will lead to distortion ("clipping") of the signal. In this fault condition the user would hear a harsh "clicking" sounds in the audio, especially when peak levels occur in the program material.

To remedy this problem simply use the Model 51 Control Console to configure the input for +4dBu operation. The distortion will go away and the gain structure of the StudioComm system will be correctly established.

## Technical Notes

### Talent Amplifier Cable Length

There are no hard and fast rules defining the maximum cable length when connecting Model 35 or Model 38 Talent Amplifiers to the Model 50 Central Controller. The maximum cable length is directly related to the amount of resistance in the connecting cable; the lower the resistance per foot (or meter), the longer the cable can be. (Although cable capacitance affects high frequency performance, resistance is the limiting factor in this case.)

To lay out the facts in grammar-school story problem format: for correct operation, a Model 35 or Model 38 needs to see at least +20Vdc between pins 1 and 2 of their input connector. The Model 50's talent amplifier output voltage across pins 1 and 2 is +23Vdc, with a maximum current draw of 0.2A (200mA). This difference between the voltage supplied and the voltage required results in a maximum voltage drop of 3V over the interconnecting cables. Since cable is rated in ohms per 1000 feet (or ohms per 1000 meters), you need to know what the maximum cable resistance is. This can be easily calculated by dividing the maximum voltage drop by the maximum current flow:  $3V$  divided by  $0.2A = 15$  ohms. For example, a standard 20 AWG microphone cable is Belden 8412, which has 10.9 ohms resistance per conductor per 1000 feet. Since we're using two conductors to carry the

signal (pins 1 and 2) you'd get 21.8 ohms per 1000 feet of microphone cable. With our 15 ohm maximum resistance you'd be able to use 688 feet (210m) of this cable.

By using the numbers provided you can select a cable, and its maximum length, for your application.

### Model 50 to Model 51 Cable Length

The Model 51 Control Console generates system-exclusive MIDI messages which are sent to the Model 50 Central Controller using a 5-conductor MIDI-style interconnecting cable. The MIDI signal is carried on two of the five conductors. The three remaining conductors are for common/shield, DC power, and communications audio. The limiting factor in the interconnecting cable's length is the transmission of the MIDI data, which has a rate of 31,250 bits-per-second. The interconductor capacitance of the cable attenuates the data, and as the cable length increases the data becomes unusable; the cable serves as a low-pass filter. The MIDI specification calls for a maximum cable length of 50 feet (15.3m), which will work fine connecting the Model 51 to the Model 50. There is really no reason why this length can't be increased, as long as good low-capacitance, shielded cable is utilized. Runs of 100 to 250 feet (30.5 to 76.2m) are possible using the latest sophisticated cable. Test to ensure that the StudioComm system works correctly with the desired cable length. There are too many variables to give a simple formula—good luck!

### Definition of Level—dBu and dBV

Whenever possible, Studio Technologies has opted to use the dBu designation as it seems to be quite rational. Using dBm was fine when all audio line outputs were



terminated with 600 ohm loads. In this way it was easy to say that 0dBm is 1 milliwatt dissipated in the known load (i.e., 0dBm across 600 ohms will measure 0.775V). In contemporary situations an output is rarely terminated with 600 ohms; generally 10k ohms or higher. The dBu designation is better because it refers to dB referenced to 0.775V, with no reference to load impedance. This takes into account today's audio scene where signals have a low source impedance, and a high input impedance. The dBu designation is becoming the standard for the professional audio industry.

StudioComm equipment is designed to interface with audio signals that have nominal signal levels of  $-10\text{dBV}$  and  $+4\text{dBu}$ . You might wonder why dBV came into the picture. Most people don't realize that equipment that utilizes " $-10$ " levels usually mean  $-10\text{dBV}$ —substantially different from  $-10\text{dBu}$  ( $-10\text{dBV} = -7.78\text{dBu}$ ). The dBV designation is simply a different way of measuring signal level and is often used when dealing with portable or consumer audio equipment. The dBV designation refers to dB referenced to 1.0V, rather than dBu which refers to 0.775V.

### **“Hot” Disconnection of the Model 51 Control Console**

Should you need to relocate the Model 51 while your StudioComm system is operating, there is no reason why you can't disconnect the 5-conductor cable, move the unit, and then connect it again. If the Model 51 is disconnected while it is operating, the current operating parameters are saved in nonvolatile memory and the Model 50 Central Controller will continue to operate as it did when the link was broken. No clicks, pops, or other noises

will occur when the Model 51 is again connected. The Model 51 will go through its standard power-up sequence, send a message to reset power-up defaults, then send the operating parameters as stored in its memory. You may notice a brief interval of silence while the Model 50 responds to the reset defaults message.

### **Control Room Mono Function**

Many arguments were had while designing the control room monaural function. Was the function supposed to be a true mono function, sending the sum of left and right to a separate mono control room output? Was mono to be the sum of left and right sent to both left and right channels? What about level build up with phase coherent signals that are in both the left and right channels? After much head scratching it was realized that the mono function that most people are accustomed to is really a means of observing the character of a stereo mix, and not a “true” mono function. To observe the stereo image of a mix you need to sum the left and right signals, drop the level of the sum, and send the result out the left and right outputs. In our implementation, we drop the level by 6dB. This is what many recording consoles implement, and is what the StudioComm does too! We understand that specialized applications such as mastering and film mixing may require a more exotic mono function. Sorry, our hardware simply can't support it!

### **Talent Amplifier Mono Function**

The Model 35 and Model 38 Talent Amplifiers each contain a monaural switch. The mono function sums the left and right input signals, drops the level of the sum by 6dB, and sends the sum to both the left and right outputs.

### **Input Level and the Talent Amplifiers**

Optimal performance of the Model 35 and Model 38 Talent Amplifiers depend on the headphone source signal levels being at approximately the nominal input level, either  $-10\text{dBV}$  or  $+4\text{dBu}$ , depending on the configuration. The headphone volume is adjusted only by the level controls on the talent amplifiers. If the selected headphone source signal level is significantly less than nominal, the talent amplifier will simply not be able to create the maximum volume in the headphones. While there is some gain in the talent amplifiers, optimal performance still requires an input close to nominal.

The Model 38 Talent Amplifier can also exhibit reduced performance if the level of the headphone source is significantly “hotter” than nominal. The entire system has plenty of headroom, but maintaining proper signal levels, as usual, is important. If the source selected for headphones has an average level that is excessive, a small amount of bleed-through can be heard with the Model 38’s cue mix level control set fully counterclockwise. Instead of having no sound in the phones, a bit of sound can be heard. This is not a design problem; the Model 38 has a sensitive preamplifier section which doesn’t like excessive excursions in the left channel modulation of the  $+23\text{Vdc}$  signal. The Model 38’s power supply can reject the left channel modulation within the design parameters, creating a clean reference voltage for the stereo preamplifier. Modulation levels outside the design parameters show up in the reference voltage!

### **Communication Switch Noise**

During field trials of the StudioComm components one item came up for

discussion concerning “thumps” in the communications functions. A brief discussion may be useful. Electrically the Model 50 and Model 51 electronics that support the communications functions are quite quiet, not adding appreciable “clicks, pops, or thumps.” Software time delays are even added to minimize noise when the buttons are pushed. Mechanical noise being picked up by the Model 51’s microphone can be an issue. If the talk to studio, talk to phones, or slate buttons are pushed using a relatively light touch no objectionable noise will be generated; pressing the switches with “gusto” will cause mechanical noise to be transferred into the microphone. While the Model 51’s microphone is of good quality, shock mounting it was not possible using a cost-effective method. The fact that the Model 51 is physically small and the buttons must be relatively close to the microphone adds to the difficulty. (Note that most all recording consoles, both small and large, share this condition.)

What are the options if the operator(s) of your Model 51 choose to use a “heavy” hand on the switches? Two are readily available: external communications switches and an external source of communications audio. A connector on the back of the Model 51 allows the connection of external talk to studio and talk to phones switches. Using external switches can eliminate the transfer of noise into the Model 51’s microphone. The Mic Module connector on the back of the Model 50 allows an external source of communications audio to be substituted for the signal provided by the Model 51’s microphone. Using a microphone and simple preamplifier (or microphones and an inexpensive mixer) you can optimize

the sound quality and location of the communications mic(s). With the Model 51's microphone no longer in use, the switches can be "beaten on" with no impact on communications audio. For details on how to implement external communication switches or to use the Mic Module input refer to other sections in the Advanced Installation Topics section of this user guide.

### **Power Amplifier Input Sensitivity**

Optimum StudioComm performance is obtained when the input sensitivity of the control room and studio power amplifiers are adjusted to match the Model 50's output level. With normal, but loud, listening levels you should find the level potentiometers on the Model 51 to be set to about 11 or 12 o'clock. If you find that you don't have to turn up the Model 51's controls that high, reduce the input sensitivity of the power amplifiers. Most power amplifiers have controls on their inputs to allow easy adjustment of the input sensitivity.

### **Control Room and Studio Output Transient Protection**

Unique to the Model 50 Central Controller is a power up/power down transient protection feature. This limits the chance of damage to the control room and studio loudspeakers during the time when AC mains voltage is connected, disconnected, or has significantly changed from nominal. A combination of hardware and software are used to monitor one of the power supply "rails." Until the power supply exceeds 81% of its nominal voltage, electromechanical relays maintain a short circuit condition on the control room A and B outputs and the studio outputs. After a one-second delay the relays are

released to function normally. Whenever the power supply drops below 79% of its nominal voltage, the relays immediately go to their mute state. During testing it was found that upon power up the outputs remained very quiet; during power down a moderate "tick" was the worst that was heard.

# Specifications

## Model 50 Central Controller

**Audio Inputs:** 7, stereo

**Type:** electronically balanced, direct coupled, compatible with balanced or unbalanced signals

**Impedance:** 24k ohms

**Nominal Input Level:** -10dBV or +4dBu, each stereo input individually software configurable

**Common Mode Rejection:** 100dB @ DC and 60Hz, 70dB @ 20kHz, 62dB @ 40kHz (typical)

**Control Room Outputs:** 2, stereo

**Type:** electronically balanced, intended to drive loads of 600 ohms or greater, balanced or unbalanced

**Nominal Level:** unity gain, audio inputs to control room outputs

**Maximum Output Level:** +27dBu into 10k ohms, +26dBu into 600 ohms

**Frequency Response:** 10Hz-40kHz +0/-0.5dB (down 1dB @ 80kHz)

**Distortion (THD+N):** 0.03% (measured at +4dBu input, +4dBu output)

**S/N Ratio:** 87dB (20Hz-20kHz)

**Studio Output:** 1, stereo

All other specifications identical to control room outputs

**Meter Output:** 1, stereo

**Type:** unbalanced, intended to drive loads of 2k ohms or greater

**Nominal Output Level:** +4dBu

**Maximum Output Level:** +21dBu into 10k ohms

**Frequency Response:** 10Hz-40kHz, +0/-0.5dB (down 1dB @ 70kHz)

**Distortion (THD+N):** 0.004% (measured at +4dBu input, +4dBu output)

**S/N Ratio:** 92dB (20Hz-20kHz)

**Talent Amplifier Output:**

**Application:** provides power and audio signals for up to four Model 35 or Model 38 Talent Amplifiers. The output connector (3-pin XLR-type, male) has common on pin 1, +23Vdc modulated with left channel audio at -10dBu on pin 2, and right channel audio at -10dBu on pin 3. Maximum output current 200mA (nominal).

**Dub Output:** 1, stereo, located on both the front and back panels

**Type:** electronically balanced, direct coupled, intended to drive loads of 600 ohms or greater, balanced or unbalanced

**Nominal Output Level:** -10dBV or +4dBu, software configurable

**Maximum Output Level:** +27dBu into 10k ohms, +26dBu into 600 ohms

**Frequency Response:** 10Hz-40kHz +0/-0.5dB (down 1dB @ 80kHz)

**Distortion (THD+N):** 0.004% (measured at +4dBu input, +4dBu output)

**S/N Ratio:** 92dB (20Hz-20kHz)

**Slate Tone:**

**Type:** 50Hz sine wave

**Level:** 10dB below slate communications audio level (nominal)

**LED Indicators:** 7, power present, control console over current, talent amp over current, input data present, Model 50 input data present, input 7 +4dBu, dub output +4dBu

**Connectors:**

**Audio Inputs and Outputs and Mic Module:** ¼-inch, 3-conductor phone jacks. Mates with all plugs specified by EIA RS-453.

**Talent Amplifier Output:** 3-pin XLR-type, male

**Control Console/MIDI In:** 5-pin DIN-type, female

**AC Mains:** 3-blade IEC-type

**AC Mains Requirement:**

100, 120, or 220/240V, ±10%, factory configured, 50/60Hz, 100-120V 0.4A maximum, 220/240V 0.2A maximum

**Dimensions (Overall):**

19.0 inches wide (48.3cm)  
1.72 inches high (4.4cm)  
8.75 inches deep (22.2cm)  
(1 standard rack space)

**Mounting:**

One space in a standard 19-inch-type rack

**Weight:**

8.9 pounds (4.1kg)

**Model 51 Control Console**

**Power Requirements:**

15Vdc filtered and regulated, 90mA maximum, provided by Model 50 Central Controller

**Connectors:**

**To Model 50 Central Controller:** 5-pin DIN-type, female

**Remote Control:** ¼-inch, 3-conductor phone jack

**Internal Microphone:**

**Type:** electret condenser

**Frequency Response:** 3dB roll off at 105Hz

**Remote Control Contacts:**

Connect normally open contacts to allow operation of remote talk to studio, remote control room source select, and remote talk to headphones functions

**Dimensions (Overall):**

7.4 inches wide (18.8cm)  
2.6 inches high (6.6cm)  
7.3 inches deep (18.5cm)

**Mounting:**

Desktop. Provision for stand mounting provided.

**Weight:**

2.5 pounds (1.1kg)

**Model 35 Talent Amplifier**

**Power Requirements:**

+20-32Vdc (modulated with left channel audio), provided by Model 50 Central Controller

**Power Present LED:** red, indicates presence of operating power

**Connectors:**

**Input (from Model 50):** 3-pin XLR-type, female

**Loop Thru:** 3-pin XLR-type, male, connected in parallel with input connector

**Headphone Outputs:** 2, ¼-inch, 3-conductor (stereo) phone jacks

**Headphone Output:** 1, feeds two headphone jacks

**Load:** intended for connection to one or two pairs of headphones with total impedance of 75 ohms or greater

**Output Level:** user adjustable

**Maximum Output Voltage:** 16V peak-to-peak into 150 ohms @ 1% THD+Noise, 400Hz

**Distortion (THD+N):** 0.03%

**Frequency Response:** 20Hz-20kHz ±0.5dB

**Dimensions (Overall):**

4.2 inches wide (10.7cm)  
2.0 inches high (5.1cm)  
5.3 inches deep (13.5cm)

**Mounting:**

Desktop. Provision for stand mounting available as option.

**Weight:**

0.8 pounds (0.4kg)

**Model 38 Talent Amplifier**

**Power Requirements:**

+20-32Vdc (modulated with left channel audio), provided by Model 50 Central Controller

**Power Present LED:** red, indicates presence of operating power

**Connectors:**

**Cue Mix Input (from Model 50):** 3-pin XLR-type, female

**Cue Mix Input Loop Thru:** 3-pin XLR-type male, connected in parallel with input connector

**Talent Input (Left In/Mono and Right In):** 3-pin XLR-type, female

**Talent Input Loop Thru:** 3-pin XLR-type male, connected in parallel with input connectors

**Headphone Outputs:** 2, 1/4-inch, 3-conductor (stereo) phone jacks

**Cue Mix Input:** intended for connection only with Model 50 Central Controller

**Talent Input:** 1, stereo or mono, switch selectable

**Type:** electronically balanced, capacitor coupled, input impedance 20k ohms

**Input Level:** switch selectable for microphone or line-level signals. Expected signal level: Mic position -40 to -60dBu, Line position -10 to +10dBu.

**Headphone Output:** 1, feeds two headphone jacks

**Load:** intended for connection to one or two pairs of headphones with total impedance of 75 ohms or greater

**Output Level:** user adjustable

**Maximum Output Voltage:** 16V peak-to-peak into 150 ohms @ 1% THD+Noise, 400Hz

**Distortion (THD+N):** 0.1%

**Frequency Response:** 20Hz-20kHz  $\pm$ 0.5dB

**Dimensions (Overall):**

8.0 inches wide (20.3cm)

2.0 inches high (5.1cm)

5.3 inches deep (13.5cm)

**Mounting:**

Desktop. Provision for stand mounting provided.

**Weight:**

1.5 pounds (0.7kg)

## **Model 70 Interface**

**Power Requirements:**

+20-32Vdc (modulated with left channel audio), provided by Model 50 Central Controller

**Power Present LED:** red, indicates presence of operating power

**Connectors:**

**Input (from Model 50):** 3-pin XLR-type, female

**Loop Thru:** 3-pin XLR-type, male, connected in parallel with input connector

**Left and Right Line Outputs:** 3-pin XLR-type, male

**Line Output:** 1, stereo

**Type:** electronically balanced, intended to drive loads of 600 ohms or greater, balanced or unbalanced

**Nominal Output Level:** +4dBu

**Maximum Output Level:** +20dBu into 10k ohms, +19dBu into 600 ohms

**Frequency Response:** 20Hz-20kHz +0/-0.5dB

**Distortion (THD+N):** 0.02%

**Dimensions (Overall):**

4.2 inches wide (10.7cm)

2.0 inches high (5.1cm)

4.7 inches deep (11.1cm)

**Weight:**

0.8 pounds (0.4kg)

Specifications and information contained in this User Guide subject to change without notice.

# Appendix A

## Controlling the Model 50

The Model 50 Central Controller uses MIDI system-exclusive messages to control all functions. The Model 51 Control Console is programmed to generate a subset of what the Model 50 is capable of doing. By using standard MIDI messages, the Model 50 can be used for a wide range of special applications. Any device that can be programmed to send system-exclusive MIDI messages can be used to control the Model 50.

All MIDI messages to be acted upon are system-exclusive type (F0H). No channel mode, system common, or system real time messages are utilized. Studio Technologies, Inc. manufacturer's ID number is 00H 00H 56H. The Model 50's product device ID number is 01H.

Note that the 5-pin connector on the Model 50's back panel is wired somewhat differently from a standard MIDI input. While pins 4 and 5 meet the MIDI standard, the three remaining pins are implemented for use by the Model 51. Pin 1 supplies +15Vdc power, pin 2 is shield (ground), and pin 3 is communications audio input.

If you're connecting your own controller, such as a computer's MIDI interface, you might be concerned about the DC power on pin 1. Because the MIDI standard doesn't use this pin, it is highly unlikely that it will be connected inside your controller, so there's little chance of the DC causing damage. To be safe, you can use a MIDI cable with only two or three wires implemented.

The following pages provide a detailed list of all Model 50 system-exclusive MIDI messages.

**Function: Reset to Power Up Default Configuration**

Byte	Value	Description
1	F0H	System-Exclusive Message
2	00H	1st Byte of Studio Tech ID
3	00H	2nd Byte of Studio Tech ID
4	56H	3rd Byte of Studio Tech ID
5	01H	Product ID (Model 50)
6	00H	Function: Restore Power Up Default Configuration
7	F7H	EOX, End of System Exclusive

**Action taken after Model 50 receives MIDI message:**

1. Set control room level to off.
2. Set studio level to off.
3. Set control room source to no input.
4. Set studio source to no input.
5. Set headphone source to no input.
6. Set dub source to no input.
7. Set control room outputs to off.
8. Set mono to off (stereo mode).
9. Set studio output to off.
10. Set all input levels to +4.
11. Set dub output level to +4.
12. Set dim to normal, non-dim
13. Set dim level to 20dB.
14. Set talk to studio to off.
15. Set talk to headphones to off.
16. Set slate to off.

**Function: Input Level**

Byte	Value	Description
1	F0H	System-Exclusive Message
2	00H	1st Byte of Studio Tech ID
3	00H	2nd Byte of Studio Tech ID
4	56H	3rd Byte of Studio Tech ID
5	01H	Product ID (Model 50)
6	01H	Function: Input Level
7	0nH	Input Channel, range 1-7, 1=input 1, 2=input 2, etc.
8	0nH	Input Level, range 0-1, 0=-10, 1=+4
9	F7H	EOX, End of System Exclusive

**Function: Dub Output Level**

Byte	Value	Description
1	F0H	System-Exclusive Message
2	00H	1st Byte of Studio Tech ID
3	00H	2nd Byte of Studio Tech ID
4	56H	3rd Byte of Studio Tech ID
5	01H	Product ID (Model 50)
6	02H	Function: Output Level
7	0nH	Output Channel, range 1, 1=dub out
8	0nH	Output Level, range 0-1, 0=-10, 1=+4
9	F7H	EOX, End of System Exclusive



**Function: Control Room Source**

Byte	Value	Description
1	F0H	System-Exclusive Message
2	00H	1st Byte of Studio Tech ID
3	00H	2nd Byte of Studio Tech ID
4	56H	3rd Byte of Studio Tech ID
5	01H	Product ID (Model 50)
6	03H	Function: Control Room Source
7	mnH	Source Selected, m range 0-2: 0=stereo, 1=left only, 2=right only; n range 0-7: 0=no input, 1=input 1, 2=input 2, etc.
8	F7H	EOX, End of System Exclusive

**Function: Studio Source**

Byte	Value	Description
1	F0H	System-Exclusive Message
2	00H	1st Byte of Studio Tech ID
3	00H	2nd Byte of Studio Tech ID
4	56H	3rd Byte of Studio Tech ID
5	01H	Product ID (Model 50)
6	04H	Function: Studio Source
7	mnH	Source Selected, m range 0-2: 0=stereo, 1=left only, 2=right only; n range 0-7: 0=no input, 1=input 1, 2=input 2, etc.
8	F7H	EOX, End of System Exclusive

**Function: Headphone Source**

Byte	Value	Description
1	F0H	System-Exclusive Message
2	00H	1st Byte of Studio Tech ID
3	00H	2nd Byte of Studio Tech ID
4	56H	3rd Byte of Studio Tech ID
5	01H	Product ID (Model 50)
6	05H	Function: Headphone Source
7	mnH	Source Selected, m range 0-2: 0=stereo, 1=left only, 2=right only; n range 0-7: 0=no input, 1=input 1, 2=input 2, etc.
8	F7H	EOX, End of System Exclusive

**Function: Dub Source**

Byte	Value	Description
1	F0H	System-Exclusive Message
2	00H	1st Byte of Studio Tech ID
3	00H	2nd Byte of Studio Tech ID
4	56H	3rd Byte of Studio Tech ID
5	01H	Product ID (Model 50)
6	06H	Function: Dub Source
7	mnH	Source Selected, m range 0-2: 0=stereo, 1=left only, 2=right only; n range 0-7: 0=no input, 1=input 1, 2=input 2, etc.
8	F7H	EOX, End of System Exclusive

### Function: Control Room Level

Byte	Value	Description
1	F0H	System-Exclusive Message
2	00H	1st Byte of Studio Tech ID
3	00H	2nd Byte of Studio Tech ID
4	56H	3rd Byte of Studio Tech ID
5	01H	Product ID (Model 50)
6	07H	Function: Control Room Level
7	0nH	Level, MSB, range 0-3, see note 1
8	nnH	Level, LSB, range 00-7F, see note 1
9	F7H	EOX, End of System Exclusive

**Note 1:** MSB=0 allows LSB to control lower 128 level steps, MSB=1 allows LSB field to control upper 128 level steps. (In operation MSB=0/LSB=00 gives full mute, MSB=1/LSB=7F gives maximum output level.)

MSB=2 places function in reduced precision mode, where LSB=00 is full mute, LSB=7F is maximum output.

MSB=3 places function in reduced precision, reverse range mode, where LSB=7F is full mute, LSB=00 is maximum output.

### Function: Studio Level

Byte	Value	Description
1	F0H	System-Exclusive Message
2	00H	1st Byte of Studio Tech ID
3	00H	2nd Byte of Studio Tech ID
4	56H	3rd Byte of Studio Tech ID
5	01H	Product ID (Model 50)
6	08H	Function: Studio Level
7	0nH	Level, MSB, range 0-3, see note 1
8	nnH	Level, LSB, range 00-7F, see note 1
9	F7H	EOX, End of System Exclusive

**Note 1:** MSB=0 allows LSB to control lower 128 level steps, MSB=1 allows LSB field to control upper 128 level steps. (In operation MSB=0/LSB=00 gives full mute, MSB=1/LSB=7F gives maximum output level.)

MSB=2 places function in reduced precision mode, where LSB=00 is full mute, LSB=7F is maximum output.

MSB=3 places function in reduced precision, reverse range mode, where LSB=7F is full mute, LSB=00 is maximum output.

**Function: Control Room Output Select**

Byte	Value	Description																																	
1	F0H	System-Exclusive Message																																	
2	00H	1st Byte of Studio Tech ID																																	
3	00H	2nd Byte of Studio Tech ID																																	
4	56H	3rd Byte of Studio Tech ID																																	
5	01H	Product ID (Model 50)																																	
6	09H	Function: Control Room Output Select																																	
7	nnH	Output Selected, Range 00-33: <table><thead><tr><th>L Ch.</th><th>R Ch.</th><th>Action</th></tr></thead><tbody><tr><td>0</td><td>0</td><td>No Output</td></tr><tr><td>1</td><td>0</td><td>Left Only, Output A On</td></tr><tr><td>2</td><td>0</td><td>Left Only, Output B On</td></tr><tr><td>3</td><td>0</td><td>Left Only, Outputs A &amp; B On</td></tr><tr><td>0</td><td>1</td><td>Right Only, Output A On</td></tr><tr><td>0</td><td>2</td><td>Right Only, Output B On</td></tr><tr><td>0</td><td>3</td><td>Right Only, Outputs A &amp; B On</td></tr><tr><td>1</td><td>1</td><td>Left and Right, Output A On</td></tr><tr><td>2</td><td>2</td><td>Left and Right, Output B On</td></tr><tr><td>3</td><td>3</td><td>Left and Right, Outputs A &amp; B On</td></tr></tbody></table>	L Ch.	R Ch.	Action	0	0	No Output	1	0	Left Only, Output A On	2	0	Left Only, Output B On	3	0	Left Only, Outputs A & B On	0	1	Right Only, Output A On	0	2	Right Only, Output B On	0	3	Right Only, Outputs A & B On	1	1	Left and Right, Output A On	2	2	Left and Right, Output B On	3	3	Left and Right, Outputs A & B On
L Ch.	R Ch.	Action																																	
0	0	No Output																																	
1	0	Left Only, Output A On																																	
2	0	Left Only, Output B On																																	
3	0	Left Only, Outputs A & B On																																	
0	1	Right Only, Output A On																																	
0	2	Right Only, Output B On																																	
0	3	Right Only, Outputs A & B On																																	
1	1	Left and Right, Output A On																																	
2	2	Left and Right, Output B On																																	
3	3	Left and Right, Outputs A & B On																																	
8	F7H	EOX, End of System Exclusive																																	

**Function: Control Room Mono/Stereo Select**

Byte	Value	Description
1	F0H	System-Exclusive Message
2	00H	1st Byte of Studio Tech ID
3	00H	2nd Byte of Studio Tech ID
4	56H	3rd Byte of Studio Tech ID
5	01H	Product ID (Model 50)
6	0AH	Function: Control Room Mono
7	0nH	Output Selected, Range 0-1, 0=stereo, 1=mono
8	F7H	EOX, End of System Exclusive

**Function: Control Room Dim**

Byte	Value	Description
1	F0H	System-Exclusive Message
2	00H	1st Byte of Studio Tech ID
3	00H	2nd Byte of Studio Tech ID
4	56H	3rd Byte of Studio Tech ID
5	01H	Product ID (Model 50)
6	0BH	Function: Control Room Dim
7	0nH	Status, Range 0-1, 0=No Dim, 1=Dim
8	F7H	EOX, End of System Exclusive

**Function: Studio On/Off Status**

Byte	Value	Description
1	F0H	System-Exclusive Message
2	00H	1st Byte of Studio Tech ID
3	00H	2nd Byte of Studio Tech ID
4	56H	3rd Byte of Studio Tech ID
5	01H	Product ID (Model 50)
6	0CH	Function: Studio Output Status
7	0nH	Status, Range 0-1, 0=Off, 1=On
8	F7H	EOX, End of System Exclusive

**Function: Talk to Studio**

Byte	Value	Description
1	F0H	System-Exclusive Message
2	00H	1st Byte of Studio Tech ID
3	00H	2nd Byte of Studio Tech ID
4	56H	3rd Byte of Studio Tech ID
5	01H	Product ID (Model 50)
6	0DH	Function: Talk to Studio
7	0nH	Status, Range 0-1, 0=no talk to studio, 1=talk to studio
8	0nH	Level, range 1-8, 8 is loudest
9	F7H	EOX, End of System Exclusive

**Function: Talk to Headphones**

Byte	Value	Description
1	F0H	System-Exclusive Message
2	00H	1st Byte of Studio Tech ID
3	00H	2nd Byte of Studio Tech ID
4	56H	3rd Byte of Studio Tech ID
5	01H	Product ID (Model 50)
6	0EH	Function: Talk to Headphones
7	0nH	Status, Range 0-2, 0=no talk to headphones, 1=talk to headphones (interrupt), 2=talk to headphones (add)
8	0nH	Level, range 1-8, 8 is loudest
9	F7H	EOX, End of System Exclusive

**Function: Slate**

Byte	Value	Description
1	F0H	System-Exclusive Message
2	00H	1st Byte of Studio Tech ID
3	00H	2nd Byte of Studio Tech ID
4	56H	3rd Byte of Studio Tech ID
5	01H	Product ID (Model 50)
6	0FH	Function: Slate
7	0nH	Status, Range 0-6, 0=no slate, 1=slate to dub output with no tone, 2=slate to dub output with tone, 3=slate to dub and headphones output (interrupt) with no tone, 4=slate to dub and headphones output (interrupt) with tone, 5=slate to dub and headphones output (add) with no tone, 6=slate to dub and headphones output (add) with tone
8	0nH	Level, range 1-8, 8 is loudest
9	F7H	EOX, End of System Exclusive

**Function: Set Dim Level**

Byte	Value	Description
1	F0H	System-Exclusive Message
2	00H	1st Byte of Studio Tech ID
3	00H	2nd Byte of Studio Tech ID
4	56H	3rd Byte of Studio Tech ID
5	01H	Product ID (Model 50)
6	10H	Function: Set Dim Level
7	0nH	Status, Range 0-5: 0=full mute (approx. 70dB) 1=30dB dim 2=25dB dim 3=20dB dim 4=15dB dim 5=10dB dim
8	F7H	EOX, End of System Exclusive

This page intentionally left blank.

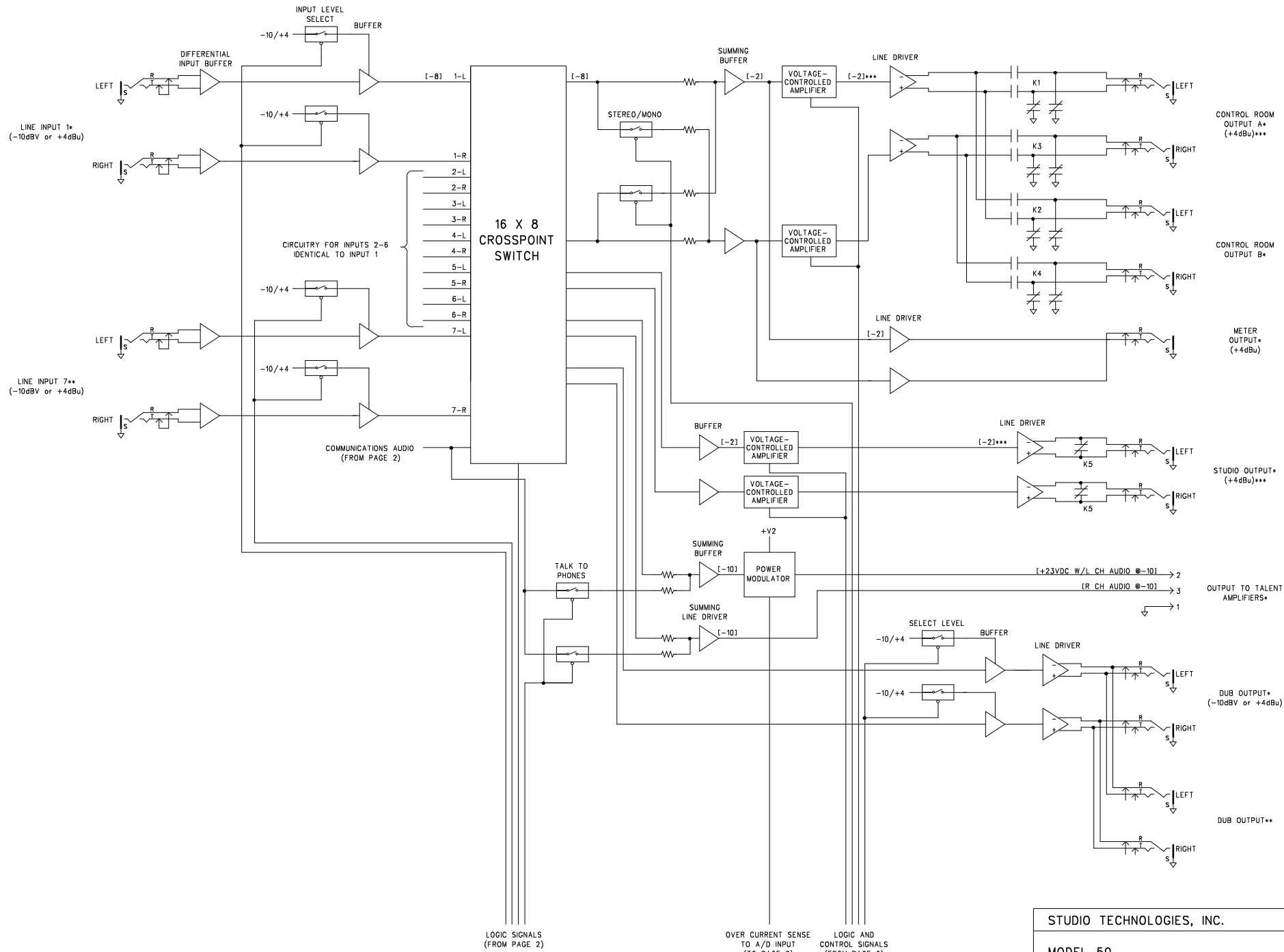

M50BD\_F

STUDIO TECHNOLOGIES, INC.		
MODEL 50 CENTRAL CONTROLLER BLOCK DIAGRAM		
DRAWING NO.	DATE	PAGE
30323	06/05/02	01 of 02

FOR SERIAL NUMBERS 00385 AND LATER

\* LOCATED ON BACK PANEL  
 \*\* LOCATED ON FRONT PANEL  
 \*\*\* W/LEVEL CONTROL AT MAXIMUM  
 (NOMINAL LEVEL IN dBu)

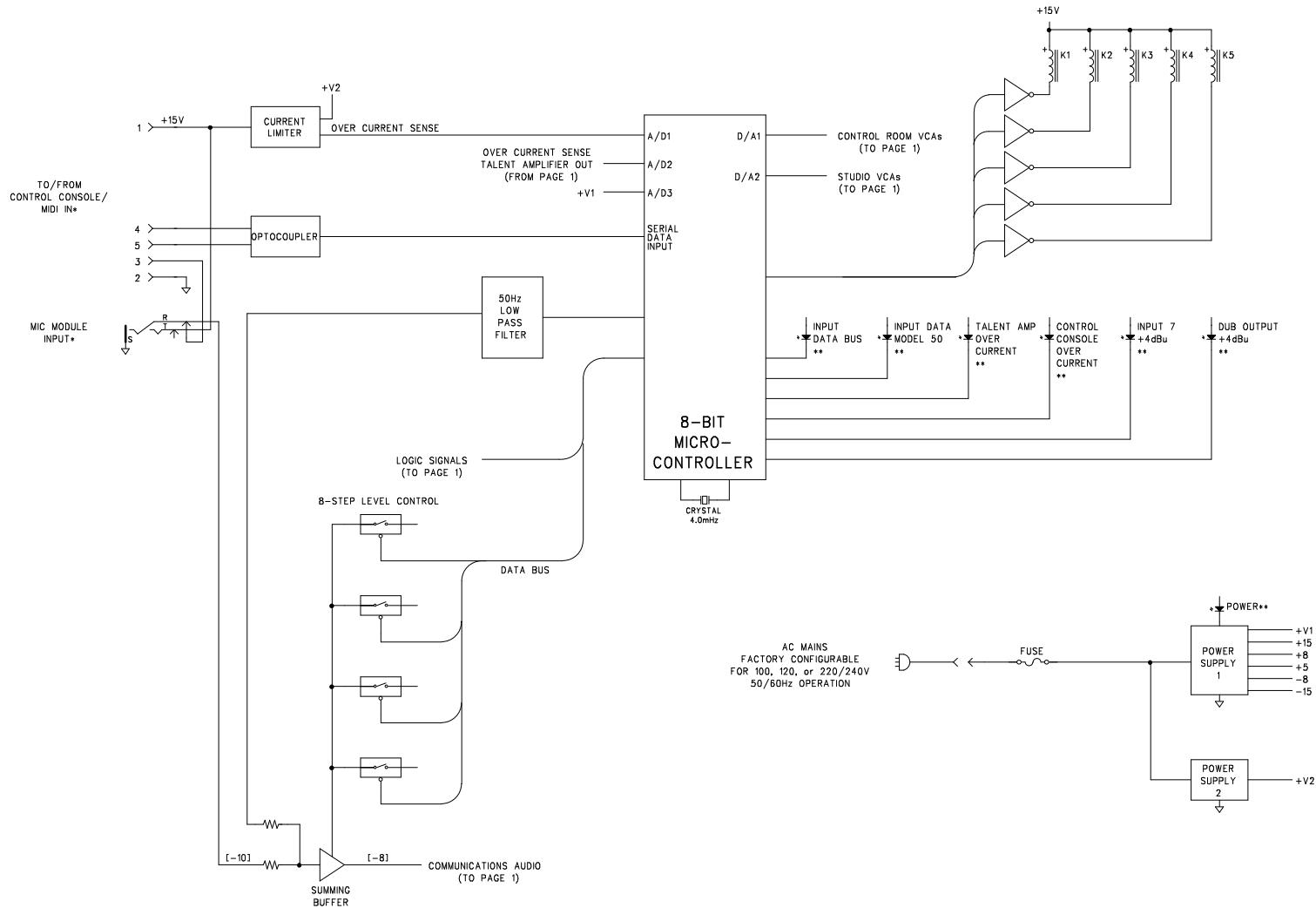

FOR SERIAL NUMBERS 00385 AND LATER

• LOCATED ON BACK PANEL  
 \*\* LOCATED ON FRONT PANEL  
 [NOMINAL LEVEL IN dBu]

STUDIO TECHNOLOGIES, INC.		
MODEL 50 CENTRAL CONTROLLER BLOCK DIAGRAM		
DRAWING NO.	DATE	PAGE
30323	06/05/02	02 of 02



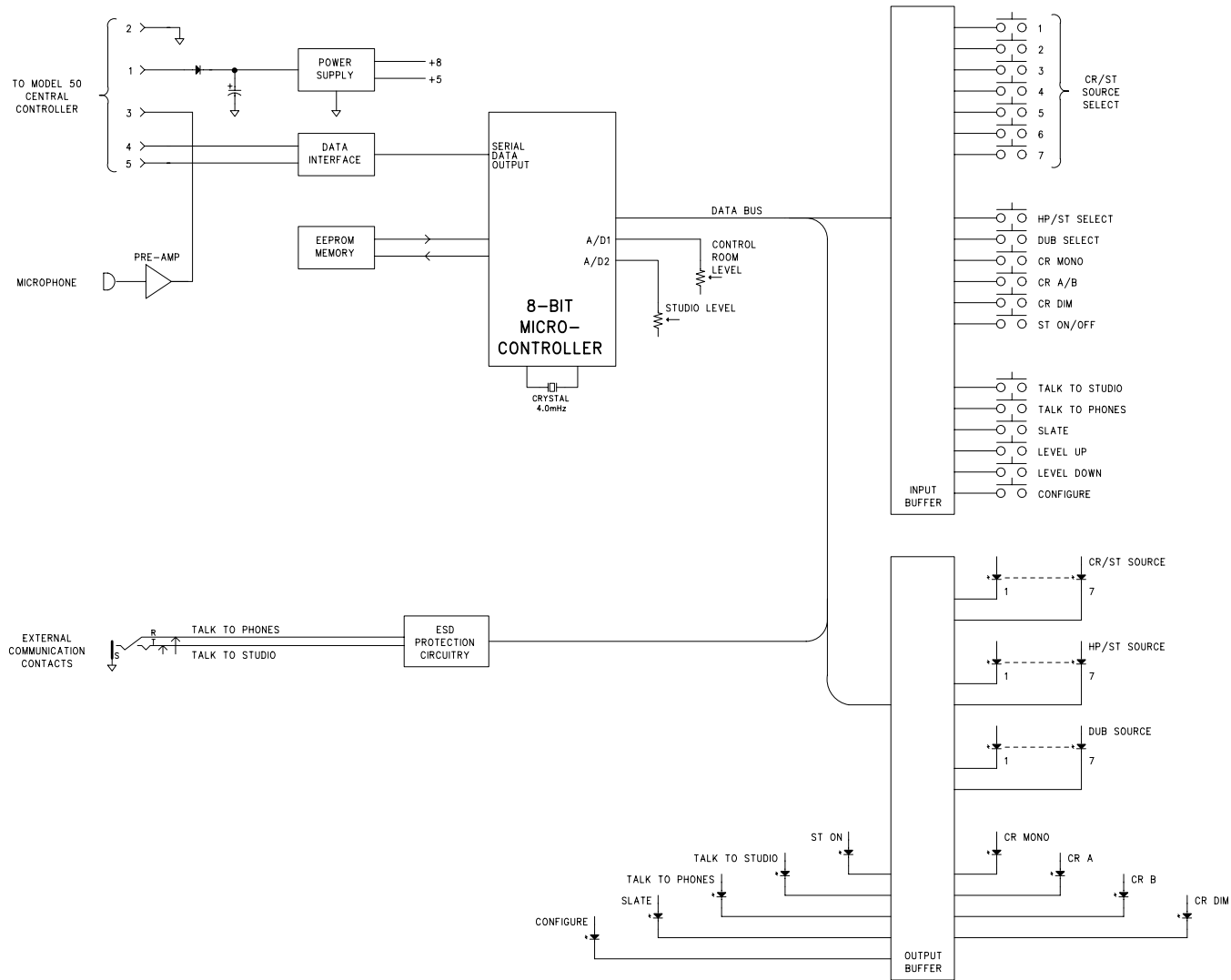

M51BD\_A1

STUDIO TECHNOLOGIES, INC.		
MODEL 51 CONTROL CONSOLE BLOCK DIAGRAM		
DRAWING NO. 30329	DATE 12/29/94	PAGE 01 OF 01

MODEL 35 TALENT AMPLIFIER

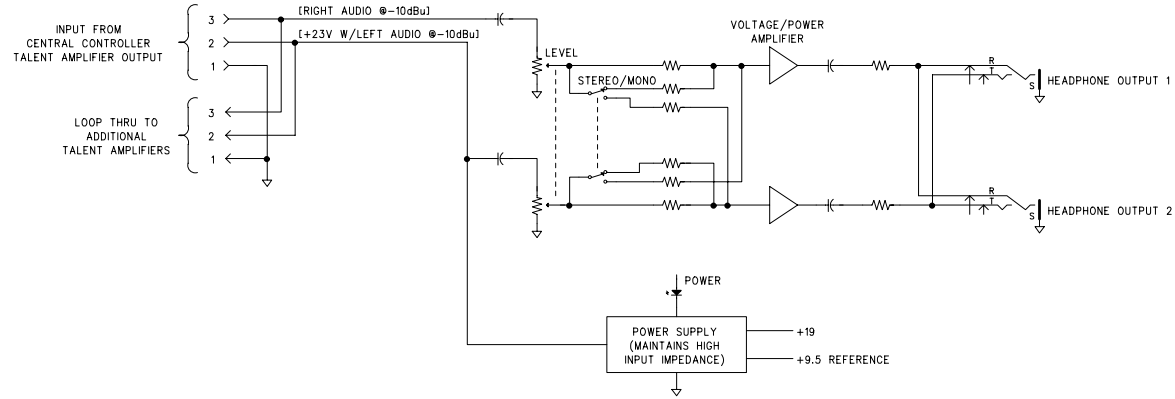

MODEL 38 TALENT AMPLIFIER

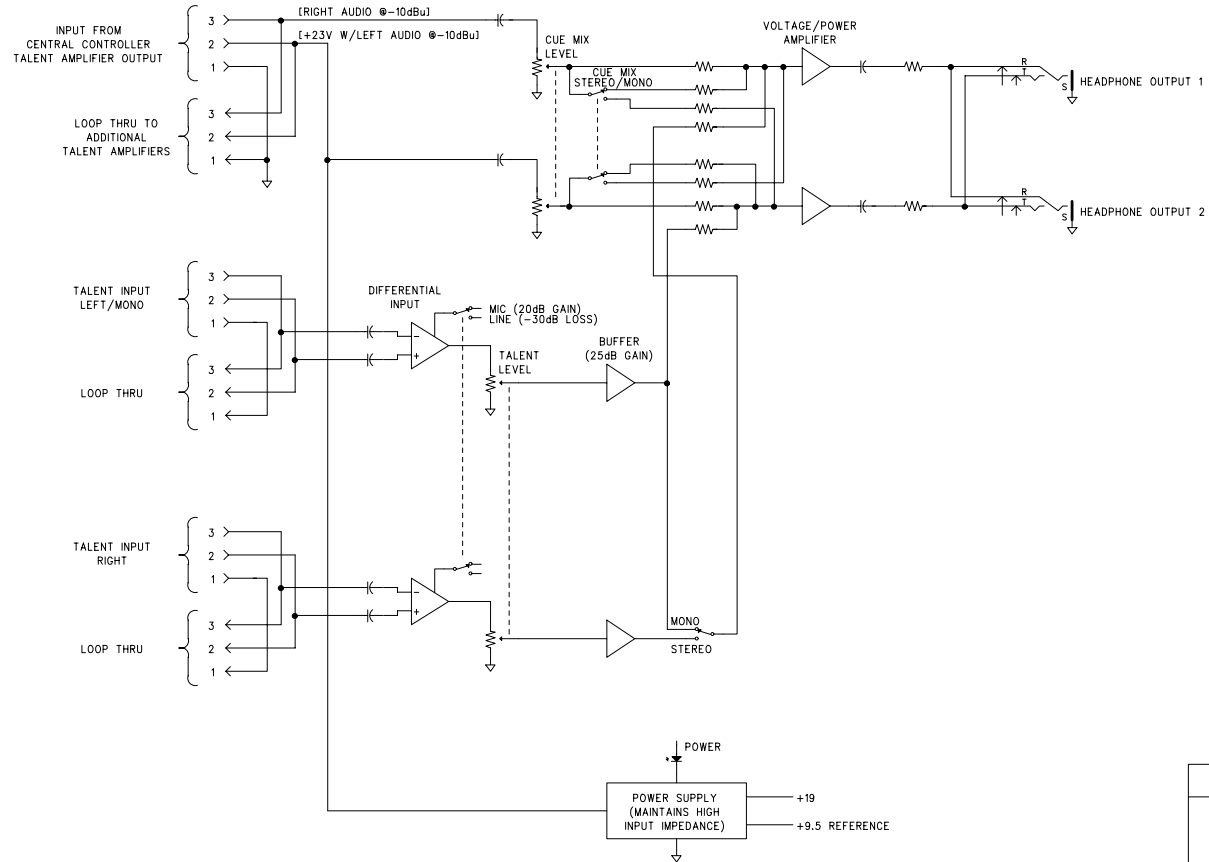

M3538BDB

STUDIO TECHNOLOGIES, INC.

MODEL 35 AND MODEL 38  
TALENT AMPLIFIERS  
BLOCK DIAGRAM

DRAWING NO.	DATE	PAGE
30312	07/27/93	01 OF 01

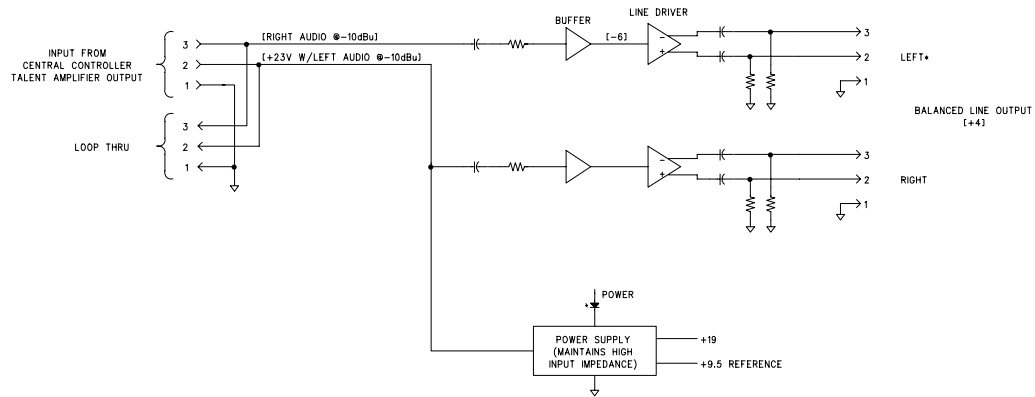

M70BD\_A

STUDIO TECHNOLOGIES, INC.		
MODEL 70 INTERFACE BLOCK DIAGRAM		
DRAWING NO. 30458	DATE 12/09/03	PAGE 01 OF 01

\* PIN 2 SIGNAL HIGH (+ OR HOT)  
(NOMINAL LEVEL IN dBu)