

# **Model 212**

Announcer's Console

## **User Guide**

Issue 2, June 2006

This User Guide is applicable for serial numbers:

M212-00151 and later

**Copyright © 2006 by Studio Technologies, Inc., all rights reserved**

[www.studio-tech.com](http://www.studio-tech.com)

# Table of Contents

Introduction .....	5
System Features .....	6
Installation and Setup .....	10
Configuration .....	15
Operation .....	24
Technical Notes.....	27
Specifications.....	34
Appendix A.....	35
Block Diagram	

This page intentionally left blank.

# Introduction

## What This User Guide Covers

This User Guide is designed to assist you when installing, configuring, and using the Model 212 Announcer's Console. Additional background technical information is also provided. A product block diagram is included at the end of this guide.

## System Overview

The Model 212 Announcer's Console is designed to serve as the audio control center for announcers, commentators, and production talent. With its digital audio input and output resources the tabletop unit is well suited for numerous applications including on-air television sports broadcasting. The broadcast-standard interfaces allow direct integration into contemporary "all digital" environments. The Model 212 integrates all on-air, talkback, and cue audio signal routing into one compact system. Some of the unit's highlights include ease of use, configuration flexibility, and sonic excellence.

Whether it's microphone preamplification, switching of main and talkback audio signals, or the headphone output, superior audio quality is maintained throughout. A microprocessor provides the Model 212's logic power, allowing precise control of the unit's operation. A range of choices allows the desired operating configuration to be easily selected. While flexible, the user is presented with an easy-to-use set of controls and indicators. The digital audio interfaces are directly compatible with system environments that use AES digital audio signals as their preferred transmission method. Unbalanced, 75 ohm interfaces are standard with balanced 110 ohm support also available.



Figure 1. Model 212 front panel



Figure 2. Model 212 back panel

A truly next-generation product, extensive research into the needs and desires of field production personnel was integral to the Model 212's creation. While primarily targeted for on-air television applications, specialized features are included to allow the Model 212 to be used in a variety of other audio applications. These include on-air radio broadcasting, stadium announcement, and voice-over/narration booths.

# System Features

## Microphone Input

A high-performance microphone pre-amplifier circuit provides low-noise/low-distortion amplification over a 10 to 50 dB gain range. The gain is adjustable in 10 dB steps. The input is compatible with balanced dynamic or condenser microphones. The microphone power source is 48 volts nominal and meets the worldwide P48 phantom standard. An LED indicator serves as an aid for optimizing the setting of the preamplifier's gain. The output of the microphone preamplifier is routed to the compressor circuit that supports the main and talkback audio channels.

## Dynamic Range Control

A studio-quality compressor circuit is provided to control the dynamic range of the analog signal coming from the microphone preamplifier. Far from a simple "clipper," the circuit utilizes a sophisticated laser-trimmed voltage-controlled-amplifier (VCA) integrated circuit for quiet, low-distortion level control. The output of the compressor is used by the main and talkback channels, being routed to the inputs of their respective analog-to-digital converter circuits. The threshold of the compressor can be configured from among two values. When configured for -4 dBFS dynamic range control will only take place as the signal approaches the level limit of the digital signal. During normal operation the compressor would not be active. With the compressor configured to -14 dBFS some dynamic range control would be expected during normal operation. While not appropriate for major on-air situations, having

dynamic range control of the signal can offer increased performance for many applications. This would be appropriate for applications such as stadium announcement positions, sports events using nonprofessional on-air talent, as well as situations where the risk of digital "clipping" is present.

## Main and Talkback Audio Channels

Internally, the Model 212 creates analog main and talkback audio channels. The main audio channel is designed to serve as the on-air, stadium announcement, or other primary audio feed. The talkback audio channel is intended to provide production trucks, control rooms, or support personnel with a talent-originated cue signal. The two analog channels are converted to 24-bit PCM digital audio and multiplexed and formatted into an AES digital audio "stream." The A/D converters and digital transmitter circuitry is synchronized ("locked") to the selected digital input signal. The system will automatically revert to the internal clock, which provides a 48 kHz sampling rate. The main audio channel is assigned to digital channel 1 with talkback audio on digital channel 2. The composite digital audio signal is routed to two physical interfaces. One output is AES3id compliant (unbalanced, 75 ohms) with a BNC connector for interfacing. This professional interface is transformer-coupled and capable of driving long broadcast cable runs.

The digital audio output signal is also routed to a unique bidirectional digital interface. Similar to AES3id, it uses a BNC connector and supports two channels of audio in each direction over a single 75 ohm cable. The bidirectional

audio interface will find use in specialized applications, including direct integration with Riedel® intercom systems. Note that audio signals received from the bidirectional interface are described in the Cue Sources section of this document.

For enhanced flexibility, the Model 212 includes the resources to support a third digital output. Circuitry, located on the printed circuit board assembly, creates an AES3 compliant, 110 ohm nominal, transformer-balanced digital output. Gaining access to this output simply requires adding a 3-pin male XLR-type connector to one of the two spare connector locations on the Model 212's back panel. Connector kits, available from Studio Technologies, make this a simple task.

For specialized applications an optional direct microphone output card is available. This allows the Model 212 to support an analog signal chain for the main output channel. Of course this output also provides "click-free" microphone on/off ("muting") control.

The Model 212 isn't limited for use in "on-air" applications. A special feature can be enabled, placing the unit in a "production" mode. When this mode is active enabling the talkback audio channel will no longer force the main audio channel to mute. This allows the main audio channel to be used as a second talkback output. In this configuration the unit can be even more powerful when used in a live event application, such as serving as a master console for a production director.

## User Controls and Status Indicators

Two pushbutton switches, three LED indicators, and two rotary controls provide

the user with a clear, easy-to-use interface. One pushbutton switch controls the status of the main audio channel. This is the audio signal intended for on-air, announcement, or other primary uses. Two LEDs display the on/off status of the main audio channel. A second pushbutton switch controls the status of the talkback audio channel. This is the audio signal used to communicate with producers, directors, spotters, or other behind-the-scenes production personnel. A status LED is associated with the talkback button. Two rotary controls allow the user to adjust the level of the stereo headphone output.

## Operational Flexibility

Much of the Model 212's unique capabilities derive from the ability to configure the on/off control of the main and talkback audio channels. To meet the needs of the many specific broadcast and production applications, a variety of button operating modes are available. The main button, located on the left side of the front panel, can be selected to operate from among four modes. In the "push-to-mute" mode the button performs a momentary mute of the main audio channel. In this way a "cough" button function is created, something typically required for television sports broadcasting. In the "push-to-talk" mode the button provides a momentary active function for the main audio channel. This mode would be appropriate for applications such as stadium announcement. An alternate action "latching" configuration allows the button to enable or disable the main audio channel as desired. This is useful in radio broadcasting, announcement, or voice-over applications. The fourth mode provides a hybrid function, supporting both push-to-talk and tap-to-enable/tap-to-disable operation. This

operation is similar to that found in many broadcast intercom system user stations.

The button associated with the talkback function can be configured to operate from either of two modes. One of the modes supports a “push-to-talk” function. This is typically used for on-air broadcast applications. The other mode provides a hybrid function, the operation of which is discussed in the previous paragraph. The hybrid mode is especially useful when the Model 212 is used in a production-support application.

## Cue Sources

The Model 212 allows two audio channels from one of three digital audio sources to be routed to the stereo headphone output. Configuration switches select which digital input is active. The available sources are the AES3id input, the previously discussed bidirectional digital interface, and the optionally implemented AES3 input. The AES3id input is an unbalanced, 75 ohm interface that uses a BNC connector. Transformer-coupled, it is compatible with standard unbalanced digital audio signals. The bidirectional digital interface is similar to AES3id but carries two audio channels in each direction. It is intended for use in special applications. The AES3 input is balanced, 110 ohms, and to use requires the addition of a connector on the unit's back panel. No matter which of the digital inputs is selected, the receiver circuitry can accept bit depths of 16 to 24. While the nominal sample rate is 48 kHz, any signal in the range of 32 to 96 kHz is acceptable. Note that the received clock signal is used for two purposes; it allows correct receiver synchronization as well as serving as the transmitter clock source for the digital outputs.

Digital-to-analog conversion circuitry creates two analog “cue” audio signals from the selected digital interface. In on-air broadcast applications these cue signals, originating in production trailers, control rooms, or remote locations, supply program-with-interrupt audio on one channel and program-only audio on the other. Each source can be individually assigned to the left channel, right channel, or both left and right. This allows a wide variety of stereo and mono headphone mixes to be created.

Some applications may benefit by being able to connect standard line-level audio signals to the Model 212. To meet this need one or two optional line input cards can be installed in the Model 212's back panel. Each card provides a female XLR-type connector and transformer-isolated +4 dBu nominal input circuit. Each source can be individually assigned to the left channel, right channel, or both left and right.

## Headphone Output

Two rotary controls are provided for user adjustment of the headphone output levels. For application flexibility the actual function of the two “pots” is configurable. For traditional on-air sports applications they can be selected to the dual-channel (“level/level”) mode which provides independent control of the left- and right-channel volume. For use with dual-channel cue signals, or to support user preference, the stereo (“level/balance”) mode can be selected. In this mode one control adjusts the overall level of both the left and right channels, while the other allows adjustment of the left/right level balance. To help minimize the chance of broadcast cues being missed, both level

control modes can be configured so that a minimum headphone output level is maintained. Alternately, the headphone output can be set to fully mute when the controls are at their minimum position. The rotary controls can also be set for a reverse left/right mode. This is provided for cases where a user needs to wear their headset “reversed” to support alternate camera angles. By using this special mode intuitive operation will be maintained and a comfortable work environment assured.

Provision has been made to support applications where a monaural cue feed is desired. A configuration switch allows the summing (combining) of the selected left and right headphone sources. In addition to creating a dual-channel mono output it also allows the level controls to be configured as a simple 2-channel mixer.

The headphone output was designed to meet the needs of contemporary headphones and headsets. Specifically, the output circuits act as voltage, rather than power, drivers. In this configuration they can provide high output levels with very low distortion and noise, along with minimal current consumption. The output circuits are configured to safely drive stereo or mono loads. This ensures that all types of headphones, headsets, and earpieces can be directly connected.

## **Audio Quality and Protection**

The Model 212’s circuitry was carefully tailored to provide excellent audio performance. Professional-quality components are featured throughout. For reliability all audio routing is performed using solid-state devices. In all critical audio paths, “clickless” performance is provided. All audio inputs and outputs make extensive

use of protection components. This limits the chance of damage from ESD and other undesirable, yet real-world, hazards.

## **Power Sources**

The Model 212 requires an external source of nominal 24 volt DC, 150 milliamperes maximum, for operation. An external power supply is included with each unit. Inside the Model 212, an internal switch-mode power supply creates the various voltage “rails” required by the internal circuitry.

As an alternative, the Model 44 Interface can be used to power the Model 212. Available from Studio Technologies, it serves as an interconnection “hub,” providing power and signal routing for up to six Model 212 Announcer’s Consoles. Refer to the Technical Notes section for details.

## **Auxiliary Relay**

Model 212 resources include a general-purpose relay, allowing specialized configurations to be created. Under software control, the relay can be configured to follow the state of the main and talkback audio channels. Taking advantage of the back-panel locations provided for additional XLR-type connectors, a technician may easily implement a variety of functions such as providing an “on-air” indicator or performing loudspeaker muting during talkback. The auxiliary relay is also used by the optional direct microphone output card.

## **Configuration**

Model 212 configurations are made using a number of DIP-type switches. One 8-position switch array is used to set the gain of the microphone preamplifier, the



on/off status of phantom power, the compressor threshold, and the headphone stereo/mono mode. Another 8-position switch array configures which of the audio sources is routed to the headphone output. A 12-position switch array communicates the desired operating modes to the microprocessor. All switches are accessible via the bottom of the Model 212's enclosure; the unit does not have to be disassembled. Changes made to any of the configuration parameters become active immediately. To prevent access to the configuration switches a security panel, included with each unit, is attached to the bottom of the enclosure.

## Connectors

The Model 212 uses standard connectors throughout. The microphone input uses a 3-pin female XLR-type connector. The digital audio inputs and outputs use BNC connectors. A ¼-inch 3-conductor jack is used for the headphone output. The external source of 24 volt DC power is connected by way of a 2.1 x 5.0 mm "locking" coaxial power jack.

In the world of broadcast and production audio it's fair to say that applications vary widely. To this end, one or two additional XLR-type connectors can easily be mounted into the Model 212's back panel. Multiple 3-position "headers" located on the Model 212's circuit board provide technician-access to all input and output connections. Using a factory-available interface cable kit allows a Model 212 to be optimized to meet the exact needs of specific applications. For example, some applications may prefer to use a multi-pin XLR-type connector to interface with a headset. This can easily be accomplished

by adding the appropriate 5-, 6-, or 7-pin XLR-type connector and making a few simple connections. Other applications may benefit from having "mult" or "loop-through" connections, something easily incorporated into a Model 212. One or two optional line input cards, as previously discussed, can also be mounted in the spare XLR positions.

## Installation and Setup

In this section interconnections will be made using the input and output connectors located on the Model 212's back panel. A microphone signal is interfaced by way of a 3-pin XLR-type connector. A ¼-inch 3-conductor phone jack is provided for the headphone output. Digital audio input and output connections are made using BNC jacks. A 2.1 x 5.0 mm coaxial jack allows connection of the external 24 volt DC power source. Depending on installed options, other connectors may be used to connect analog, digital and power signals.

## System Components

The following are included in the shipping carton: Model 212 Announcer's Console, user guide, button label sheet, and 24 volt DC power supply. For units shipped to destinations in Japan and North America the power supply will have a nominal AC mains input of 120 volts. For all other destinations a power supply compatible with 100 to 240 volts AC mains will be included.

## Microphone Input

The Model 212 is compatible with balanced dynamic and condenser microphones. Depending on the application, the microphone may be part of a headset, or be an independent handheld or stand-mounted model. The Model 212's 48 volt nominal power source will support essentially all phantom-powered microphones. The quality of the Model 212's microphone preamplifier and associated circuitry is such that special applications may benefit from using "high-end" microphones. If selected appropriately, models from manufacturers such as AKG, Beyer, DPA, Neumann, Sennheiser, and Shure will perform very well in Model 212 applications.

Microphone interconnection is made by way of a 3-pin female XLR-type connector which is located on the Model 212's back panel. The mating connector (male) should be wired so that pin 2 is signal high (+ or hot), pin 3 is signal low (- or cold), and pin 1 is shield. It's possible that an unbalanced microphone will also work correctly. In this case, the mating connector (male) should be wired so that pin 2 is signal high (+ or hot), and signal common/shield is connected to both pins 1 and 3.

The Model 212 is not compatible with unbalanced "electret"-type microphones that require a source of low-voltage DC for operation. These microphones, sometimes found in low-cost headsets, are not generally suitable for on-air or other demanding applications.

As of the writing date of this user guide, the Sennheiser HMD25 headset is very popular for on-air sports broadcasting use. A fine product, it works very well with the Model 212. Note that adding the

suffix "-XQ" to the headset's part number (HMD25-XQ) specifies a 3-pin male XLR-type connector for the dynamic microphone and a 1/4-inch 3-conductor plug for the stereo headphones. This configuration is very useful, allowing the headset to work directly "out of the box" with the Model 212.

If the writer may digress for a moment to recount a story... an audio dealer once shared a secret with me concerning headsets. He loved selling the "lower-end" (less expensive) models of name-brand headsets, which he did by the veritable "boat-load." Why? Because these usually broke soon after going into service! He knew that on a regular basis he'd receive orders for more of them. Had these users, from the beginning, purchased only premium-quality headsets, their total cost of ownership would have been much less. Enough said...

## Headphone Output

The Model 212's headphone output is compatible with stereo or mono headphones, headsets, or earpieces. Connecting devices with a nominal impedance of 100 ohms or greater is preferred. This shouldn't prove to be an issue as essentially all contemporary devices already meet this condition.

Devices are connected to the headphone output by way of a 1/4-inch 3-conductor phone jack located on the Model 212's back panel. As is standard for stereo headphones, the left channel is connected to the "tip" lead of the 1/4-inch headphone jack. The right channel is connected to the "ring" lead of the jack. Common for both channels is connected to the "sleeve" lead.

Devices with ¼-inch 2-conductor “mono” plugs can also be used with the Model 212’s headphone output. In this arrangement only the tip lead (left channel) will be active. The 2-conductor plug will physically connect (“short”) the ring lead (right channel) to the sleeve lead (common). Technically this won’t damage the circuitry associated with the right-channel headphone output. (51 ohm protection resistors are electrically in series with the headphone output circuits.) However energy will be wasted if an audio signal coming out of the right channel goes into a “dead short.” There is a simple solution to this issue. No cue audio source should be assigned to the right-channel headphone output. Refer to the Configuration section of this user guide for details.

## AES3id Output

The main and talkback audio channels are accessible by way of an AES3id digital audio output. A BNC connector, located on the back panel of the Model 212, provides access to the transformer-coupled interface. This type of digital audio interface is commonly used for broadcast applications, providing a 75 ohm unbalanced implementation of the AES 2-channel digital audio standard. The Model 212’s interface provides 24 bit audio signals with a default sample rate of 48 kHz. The main output audio signal will be present on channel 1 of the digital audio signal; talkback audio will be present on channel 2.

Note that the clock source for the digital audio output is derived from the selected digital audio input. Should the input source not be present the Model 212’s internal clock source will automatically be selected. The exception is when the bidirectional digital interface is selected

as the input source. In this case a valid signal must be connected to the bidirectional digital interface for proper digital audio output signals to be created; the Model 212 is not be able use its internal clock source.

The main output channel is intended to be the “on-air” signal that connects to an input channel of an audio console. The talkback output channel is intended for connection to control rooms, production trailers, or other locations where talent-originated voice cues are required. The nominal level of the digital audio signals is –20 dBFS. The actual levels will depend on the gain setting of the microphone preamplifier, sensitivity of the microphone, how loudly the talent speaks into the microphone, and the configuration setting of the compressor threshold.

Talkback audio is also “on-air” quality, which makes sense as the audio path is shared by the talkback and main output channels. Devices connected to the talkback output channel can range from amplifiers associated with loudspeakers to inputs on digital matrix intercom systems. Connecting the talkback output channel to devices that allow easy control of the signal level can be helpful. For example, connecting to a spare input channel on a digital audio console will provide the resources to add gain or attenuation as required. A talkback-associated output path on the audio console can then connect to the final destination(s).

## Optional AES3 Output

Circuitry contained within the Model 212 allows a technician to add support for an AES3 output. This type of interface allows two channels of digital audio to be carried over a balanced 110 ohm circuit. In

some Model 212 applications the AES3 output will be implemented using a 3-pin male XLR-type connector installed in the back panel. Other applications may use a multi-pin connector, such as the Neutrik® EtherCon® version of the 8-pin RJ45 jack.

Note that the signal coming out of the AES3 output will be identical to that coming out the Model 212's AES3id output. The same content will be transmitted at the same bit depth and clock rate. For full isolation separate circuitry, including matching transformers, is provided for the two outputs.

## AES3id Input

The AES3id input can be used to connect digital audio signals to the Model 212. The two audio channels associated with the interface will serve as cue sources for the stereo headphone output. The input, physically a BNC connector located on the Model 212's back panel, allows a depth of up to 24 bits to be supported; however anything in the range of 16 to 24 bits will work correctly. The input is "self-clocking" so that compatibility with virtually any AES3id source should be possible. It's expected that in most cases the Model 212 will be used in professional audio environments where the sample rate will be 48 kHz. However, any source with a sample rate from 32 to 96 kHz will also work correctly.

For the AES3id input to be active a configuration setting must be correctly made. This topic is discussed in detail in the configuration section of this user guide. It's also important to note that the selected digital input source will also serve as the clock source for the Model 212's digital outputs.

## Optional AES3 Input

Circuitry contained within the Model 212 allows a technician to add support for a standard AES3 input. This type of interface allows two channels of digital audio to be received over a balanced, transformer-coupled, 110 ohm circuit. In some Model 212 applications the AES3 input will be implemented using a 3-pin female XLR-type connector installed in the back panel. Other applications may use a multi-pin connector, such as the Neutrik EtherCon version of the 8-pin RJ45 jack.

As with the AES3id input, for the AES3 input to be active the appropriate configuration DIP switches must be set. And as with the AES3id input, in addition to providing cue audio sources for the stereo headphone output, the AES3 input will also serve as the clock source for the Model 212's digital outputs.

## Bidirectional Digital Interface

The Model 212 includes a bidirectional digital interface for use in special applications. Using a single 75 ohm, unbalanced connection, two channels of digital audio can be both sent and received. The two channels of receive audio can be used as cue sources for the stereo headphone output. Bit depths of up to 24 and sample rates of 32 to 96 kHz are supported. For the bidirectional digital interface to be active the appropriate configuration DIP switches must be set.

The ability of the bidirectional digital interface to send and receive digital audio signals over one cable makes interconnecting the Model 212 with other equipment incredibly simple. For example, the bidirectional digital interface is directly compatible with the Riedel Artist® digital

matrix intercom system. A single cable is all that is required to interface an Artist digital port with the Model 212.

## Optional Analog Line Inputs

While the Model 212's headphone sources were designed primarily to be supplied using one of the digital audio inputs, it's also possible to connect one or two analog line-level audio sources. Please refer to the Technical Notes section of this user guide for details.

## External Power Input

The Model 212 requires an external source of 24 volt DC power for operation. It is connected by way of a 2.1 x 5.0 mm coaxial power jack which is located on the back panel of the unit. The center pin of the jack is the positive (+) connection. While the requirement for the external source is nominally 24 volts, correct operation will take place with any source within the range of 20 to 30 volts. A maximum current of 150 milliamperes at 24 volts DC is required. Included with each Model 212 is a 24 volt DC external power supply. The power supply's DC output cable has been terminated with a Switchcraft® S760K coaxial power plug. This "locking" type of plug correctly mates with the Model 212's 24 Vdc input jack. The locking feature is important, allowing the external power source to be securely attached to the Model 212.

## Pushbutton Labeling

The two pushbutton switches used in the Model 212 were selected for several reasons. Foremost was the fact that they are highly reliable, using gold-plated contacts for long life in less-than-ideal environments. A second reason was that applying

customized labels to the button caps would be very simple. The labels, text printed on clear material, are placed under the clear caps on the top of the buttons.

From the factory the left button is labeled COUGH and the right button is labeled TALKBACK. This was selected to be appropriate for many on-air applications in English-speaking locations. But it's expected that these may need to be changed to meet the needs of specific applications.

As a "head start" for some applications, a clear sheet with a number of commonly used button designations printed on it is included in the shipping carton. These were created at the factory using a standard personal computer graphics program and laser printed onto 3M CG3300 transparency film. The desired button labels can be cut out with a pair of scissors, following the printed guide lines that indicate the required size.

The clear lens on top of each button cap can be removed with a fingernail or small screwdriver. Be certain not to scratch the button if a screwdriver or other small tool is used. The clear label can be removed and replaced. The button cap is then snapped back into the top of the button housing using finger-pressure only. No tool is required to replace the button cap.

If you need to make your own labels the process is quite simple. Use a personal computer to create the desired text. The finished label size should be 0.625-inches (15.8 mm) square. The completed artwork can then be printed on transparency film sheets using a laser or inkjet printer. These sheets are readily available from most office supply stores. A pair of scissors or an X-ACTO® knife will complete the task.

# Configuration

For the Model 212 to support the needs of specific applications a number of operating parameters must be configured. These include microphone preamplifier gain, phantom power on/off, headphone cue source selection, headphone mono/stereo mode, and a number of operating modes. Two 8-position and one 12-position DIP-type switch assemblies are used to establish the desired configuration. These switch assemblies are referred to as Switch 1, Switch 2, and Switch 3, with individual switches designated as SW1-1, SW1-2, etc. The switch assemblies are

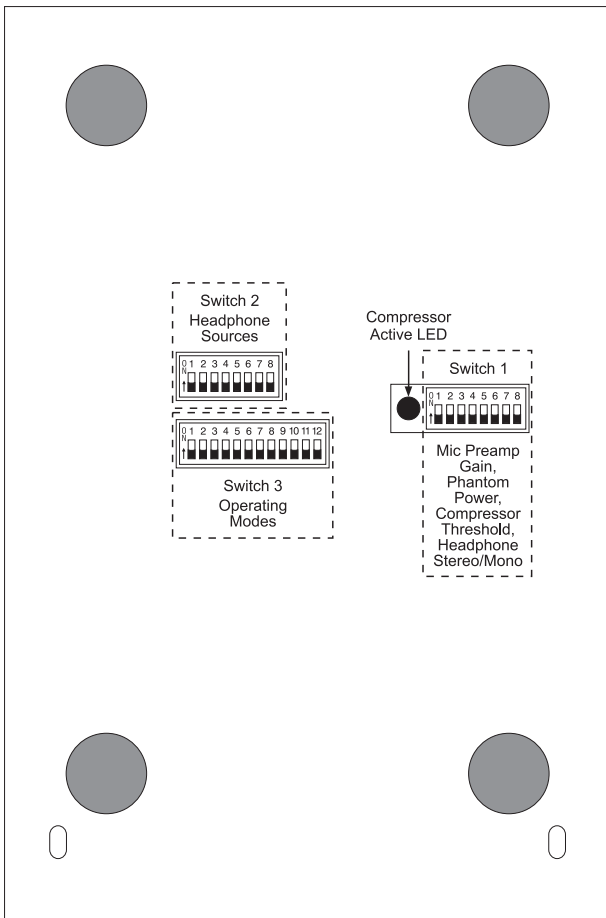

**Figure 3. Bottom view of Model 212 showing configuration switches and compressor active LED**

accessed through openings in the bottom of the Model 212's enclosure. The enclosure does not have to be disassembled to gain access to the switches.

To prevent unauthorized personnel from changing the configuration settings, a security plate is attached to the bottom of the Model 212's enclosure. For convenience, a configuration settings label is attached to the security plate. It provides a summary of the configurable parameters and related information. Refer to Appendix A for a representative view of the label. The security plate is held in place by means of four rubber bumpers ("feet") that have built-in screws. Using your fingers, remove the four bumpers so that the plate can be removed. Refer to Figure 3 for a detailed view of the configuration switch assemblies.

## Microphone Preamplifier Gain and Phantom Power

Five switches are used to set the gain of the microphone preamplifier. One switch is used to select the on/off status of the phantom power supply.

### Microphone Preamplifier Gain

Switches SW1-1 through SW1-5 are used to select the gain of the microphone preamplifier. The choices are 10, 20, 30, 40, and 50 dB. Only one switch should be enabled at a time. There's no problem changing the gain setting while the unit is operating. Audio clicks or pops might occur during gain transitions, but this shouldn't be a major issue as long as associated monitor loudspeakers are temporarily attenuated or muted.

Selecting the correct amount of gain for an application might take a little experimentation. The goal is to bring the mic's signal

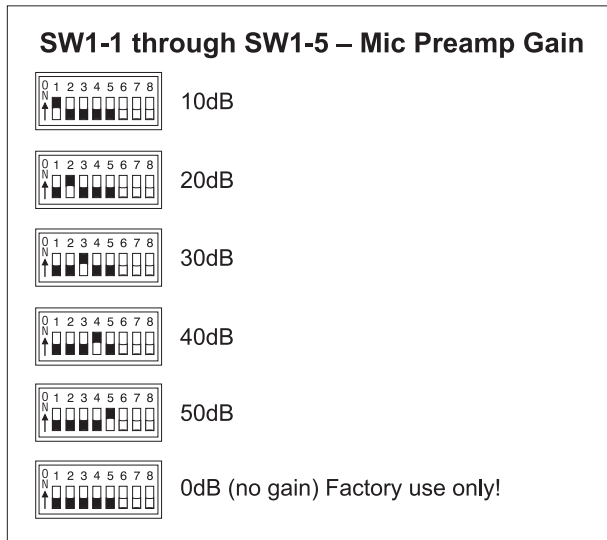

**Figure 4. Microphone preamplifier gain switch settings**

level up such that the main and talkback output levels will match the Model 212's nominal digital output level which is  $-20$  dBFS. Operating at this signal level will help to ensure the delivery of "clean" audio with adequate level "headroom." The output of the Model 212's microphone preamplifier is routed to the input of the compressor circuit.

Unfortunately, there's no "perfect" gain setting that this guide can recommend. The two issues that impact the setting are output sensitivity of the connected microphone and the acoustical output level of the microphone's user. With some headset microphones, such as the Sennheiser HMD25, selecting an initial setting of 30 dB is appropriate. Users who speak loudly might need to have the gain reduced to 20 dB. Quiet users might need 40 dB of gain.

An LED indicator is provided as an aid in correctly setting the gain of the microphone preamplifier. Red in color, this LED

is located adjacent to switch assembly 1. It is visible by observing the bottom of the Model 212's enclosure when the security plate has been removed. Technically, this red LED lights whenever the compressor circuitry is controlling the dynamic range of the signal coming from the microphone preamplifier. Using configuration DIP switch SW1-7, the compressor's threshold will be set to either  $-14$  or  $-4$  dBFS. (Details concerning setting the compress threshold are discussed later in this user guide.) If the threshold is set for  $-14$  dBFS a good "rule of thumb" is to adjust the gain of the microphone preamplifier such that the compressor active LED will light ("flash") only when the connected microphone is sending signal peaks. During normal operation the LED should never remain fully lit when audio of typical signal level is present on the mic input.

If the threshold is set for  $-4$  dBFS the LED should light only on extreme signal peaks, or possibly never. This is because with a  $-4$  dBFS threshold the compressor is intended only to prevent signals from ever causing the maximum digital level of 0 dBFS to be reached. It's not supposed to reduce the dynamic range of normal program material. As an aid in setting the microphone preamplifier's gain, it might be useful to temporarily set the compressor's threshold to  $-14$  dBFS. Once the gain has been set so that the LED lights only on peaks the threshold can be returned to the  $-4$  dBFS setting.

It's expected that the 10 and 50 dB gain settings will not be used often. But there are always exceptions and that's why they are included. It's possible that with a very "hot" microphone, such as a phantom-powered condenser-type, 10 dB of gain

could be correct. It's also possible that a microphone with a very low-level output, such as a ribbon-type, would need 50 dB of gain. But in general, the 20, 30, and 40 dB gain settings will serve most applications.

Note that if no gain switch is set to its active (on) position the preamplifier will operate at unity (0 dB) gain. In this mode the pre-amplifier will remain stable, but is intended for use only during factory testing. A valid exception would be where a line-level signal is connected to the microphone input. This could occur with a special Model 212 application. But with a microphone connected as the input source one should never use the 0 dB setting. The issue is that with no gain added to the microphone input signal, the relative noise floor on the main and talkback output channels will be much too high. In conclusion, the 0 dB gain setting doesn't highlight a problem, but simply reflects the unit's gain structure.

### Phantom Power

The Model 212 can provide 48 volt phantom power to the microphone input. Switch SW1-8 controls whether or not phantom power is active. By phantom power's very nature it could be left applied to the microphone input at all times. But generally people prefer to turn it off unless it is required for a specific microphone.

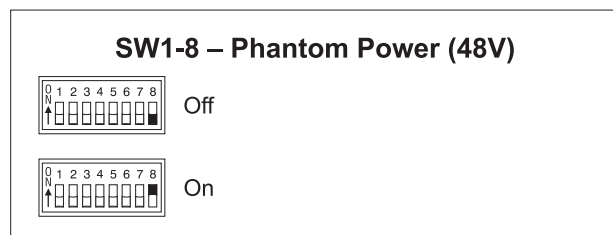

**Figure 5. Phantom power switch settings**

### Headphone Source Selection

Switch assembly SW2 is used to configure the source or sources that are routed to the stereo headphone output. Up to four sources may be available with the choices being digital input channel 1, digital input channel 2, auxiliary input 1, and auxiliary input 2. The digital input channels are provided by the selected digital input source. The digital input source is configured from these choices: the AES3id input, the optional AES3 input, or the bidirectional digital interface. The auxiliary inputs are analog and available only if optional line input cards have been installed. Alternately, a special Model 212 configuration may have been implemented that uses one or both of the auxiliary inputs.

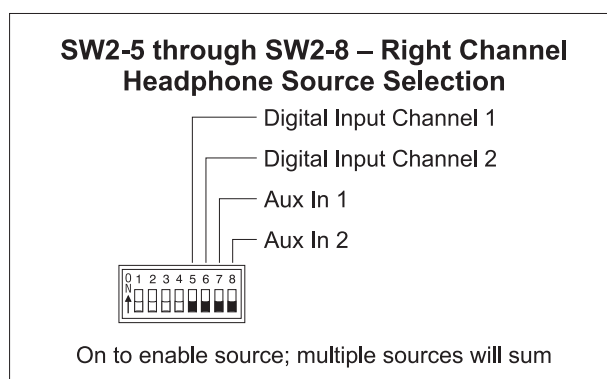
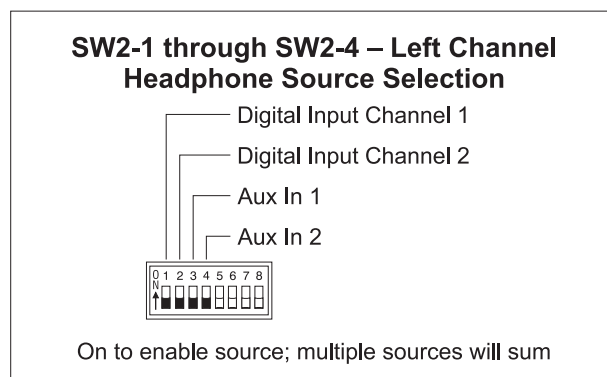

**Figure 6. Left and right channel headphone source selection settings**



Each of the available input sources can be assigned to the headphone output's left channel, right channel, or both the left and right channels. The Model 212's circuitry allows any combination of input assignments to be made. For example, consider the situation where a single digital input channel is actively connected to the Model 212. In this case it may be desirable to assign this signal to both the left and right headphone channels. This would entail setting switches SW2-2 and SW2-6 to their on positions. All other switches would remain in their off positions.

A more complex application might have a 2-channel digital audio signal connected to the Model 212, with an optional line input card installed. Line-level audio from a golf event "spotter" is connected to the line input. In a case such as this, it would be typical for digital input channel 1 to be assigned to the headphone's left channel, digital input channel 2 assigned to the right channel, and auxiliary input 1 also assigned to the right channel. This would allow both digital input channel 2 and "spotter" audio to be heard in the headphone's right-channel output. To achieve this would require that switches SW2-1, SW2-6, and SW2-7 be placed in their on positions. Note that using another Studio Technologies 200-series announcer's console at the "spotter" location could also prove effective. It would provide all the necessary microphone preamplifier, talkback routing, and headphone monitoring resources.

In some cases a user may wish to wear a headset or a pair of headphones in a left/right orientation opposite of what's usual. In this situation the transducer designated for the left ear would actually supply audio to the user's right ear, and vice versa.

A specific application where this can occur is when on-air talent needs to have a headset's boom microphone come across the right side of their face, rather than the more-typical left side. In this case it's important to select the left- and right-channel headphone source assignment accordingly. With the Model 212's flexible source selection there's no reason why users, such as on-air talent, shouldn't have their cue sources assigned correctly.

There may be cases where a monaural "single-muff" headset or headphone will be connected to the Model 212's headphone output. In this case the desired cue source(s) should be routed only to the left channel. No sources should be assigned to the right channel. This will eliminate the short-circuit current that could occur when a 2-conductor (monaural) plug is mated with the Model 212's 3-conductor (stereo) headphone output jack.

## Headphone Output Mode

Switch SW1-6 allows a monaural headphone output to be created. This is accomplished by summing (adding) the selected left- and right-channel cue signals. The combined signals are sent to both the left- and right-channel headphone output driver circuits. The outputs of these circuits connect, by way of 51 ohm series protection resistors, to the headphone output jack.

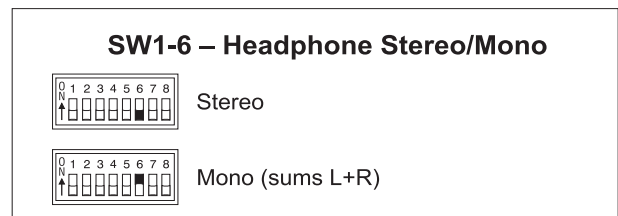

**Figure 7. Headphone output mode settings**

The headphone output monaural mode feature was specifically included so that a special “2-channel headphone mix” mode can be created. By enabling the mono mode, the two front-panel user level controls (“pots”) can be used to create the desired “mix” of signals being sent to the headphone output. Many applications, especially in production settings, can benefit from this capability. The desired cue sources must be carefully assigned to take advantage of the monaural mode. The first cue source should be assigned, using the DIP-type switches, to the left channel. Its output level will be adjusted by the left control. The second cue source should be assigned to the right channel. Its output level will be adjusted by the right control.

There is one limitation related to the headphone mono output mode. It’s the fact that the output will be 2-channel monaural. Whatever signal is present on the headphone output’s left channel will also be present on the right channel. A stereo headphone mix can’t be created. But in most cases this limitation won’t overshadow the benefit of being able to create the mix. For signal-flow clarification please review the block diagram located at the end of this user guide.

## Operating Modes

The twelve switches associated with switch assembly 3 are used to configure the Model 212’s operating modes. Technically, these switches “talk” to the micro-controller integrated circuit and associated software that give the Model 212 its “smarts.” The software has been carefully designed to provide a number of different ways in which the unit can function. It’s critical to carefully review the available

options and choose the ones that best meet the needs of a specific application. Note that switches can be changed even while the Model 212 is powered up and operating. The unit’s operating characteristics will change in “real-time” in response to configuration changes.

### Main Output Button Mode

Switches SW3-1 and SW3-2 configure how the main output button functions.

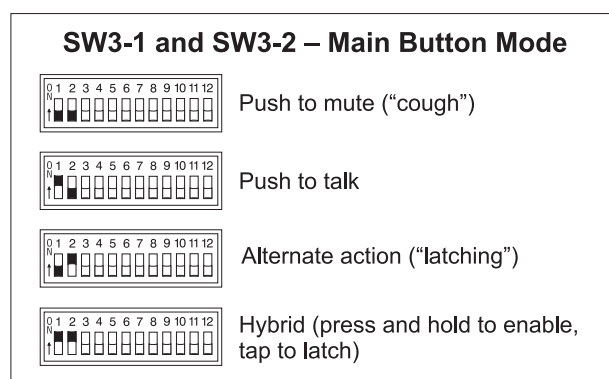

**Figure 8. Main output button mode settings**

There are four available modes:

- **Push to mute:** In this mode the main output channel is normally active. The main output channel will mute (have minimum digital audio level) whenever the button is pressed and held. This is the “cough” mode typically used for on-air sports broadcasting applications.
- **Push to talk:** In this mode the main output channel is normally muted. The main output channel will become active whenever the button is pressed and held.
- **Alternate action:** In this mode the main output channel will change between its active and muted state whenever the button is pressed. Upon power up the main output channel will be in its muted state.

- **Hybrid:** This mode is a combination of push to talk and alternate action. It's similar to the way talk buttons function on user stations associated with broadcast and production intercom systems. If the button is pressed and held, the main output channel will become active until the button is released. If the button is momentarily "tapped" the main output channel will change state. Upon power up the main output channel will be in its muted state.

### Talkback Output Button Mode

Switch SW3-3 configures the way the talkback output button functions.

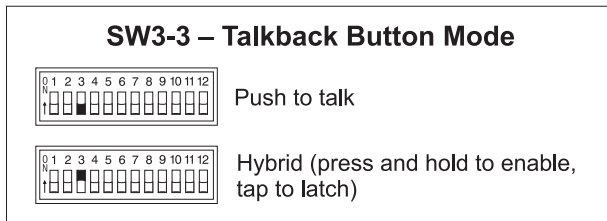

**Figure 9. Talkback output button mode settings**

Two modes are available:

- **Push to talk:** In this mode the talkback output channel is normally muted (minimum digital audio level). The talkback output channel will become active whenever the button is pressed and held.
- **Hybrid:** This mode is a combination of push to talk and alternate action. If the button is pressed and held, the talkback output channel will become active until the button is released. If the button is momentarily "tapped" the talkback output channel will change state. Upon power up the talkback output channel will be in its muted state.

### Headphone Output Operating Modes

The user is provided with two rotary level controls ("pots") that are associated with the stereo headphone output. Switches SW3-4, SW3-5, and SW3-6 are used to configure the way the controls function. With just these three switches a wide range of operating modes can be configured. Carefully reviewing the capabilities of the available functions may prove worthwhile.

### Dual-Channel or Stereo Mode

Switch SW3-4 is used to select whether the controls provide a dual-channel ("level/level") or stereo ("level/balance") mode of operation. In the level/level mode the two controls operate independently, each controlling the level of one of the headphone output channels. This mode is generally used for on-air broadcast applications where independent cue signals are provided to the left- and right-headphone channels. In the level/balance mode the left rotary control sets the overall output level for both headphone channels. The right rotary control is used to adjust the balance (the relative levels) of the left and right channels. This mode is generally best suited for applications where a stereo cue source is being provided.

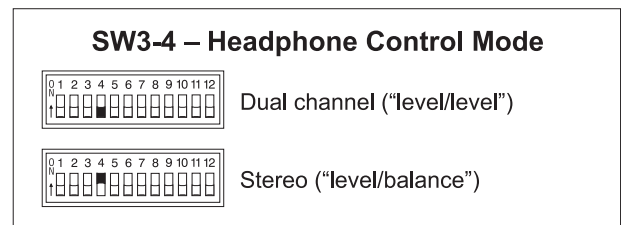

**Figure 10. Headphone control mode settings**

### Reverse Left/Right Mode

Switch SW3-5 is used to select whether the rotary controls are in the normal or reverse left/right mode of operation.

When selected to the normal mode, and level/level mode is also selected, the left control adjusts the level of headphone output's left channel. (This is the signal that appears on the tip lead of the 1/4-inch 3-conductor jack.) The right control adjusts the level of the right channel. When selected to the normal mode, and the level/balance mode is also selected, turning the balance control in the counterclockwise direction increases the perceived level of the left channel output, and vice versa.

As you may have already guessed, when selecting the reverse left/right mode of operation everything is reversed! To be more specific, when selected for reverse mode, and the level/level mode is also selected, the left control adjusts the headphone output's right channel (output jack's ring lead) while the right control adjusts the left channel. When selected to the reverse mode, and the level/balance is also selected, turning the balance control in the counterclockwise direction increases the perceived level of the right channel output, and vice versa.

The reverse mode is provided specifically for cases where a headset's left and right ear pieces are placed on a user's head

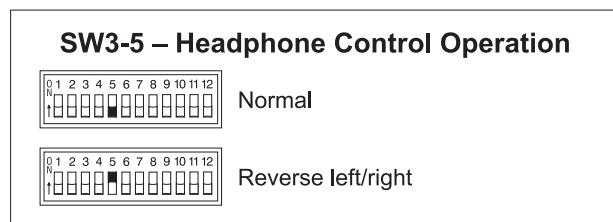

**Figure 11. Headphone control operation settings**

in a reverse orientation. This ensures that the user is provided with a consistent and easy-to-use set of headphone level controls.

### Minimum Level Mode

Switch SW3-6 is used to configure the headphone output's minimum level. In the -40 dB mode the minimum headphone output level is 40 dB below maximum. The headphone output channels will never fully mute. This ensures that any audio signal present on the selected cue audio source will always be present on the headphone output. In most on-air broadcast applications this is the appropriate setting.

When the full mute mode is selected, and the level/level mode is also selected, moving either control to its fully counterclockwise position will cause its associated channel to fully mute.

When the full mute mode is selected, and the level/balance mode is also selected, turning the level control to its fully counterclockwise position will cause both headphone channels to mute. Turning the balance control to either its fully clockwise or fully counterclockwise position will cause the appropriate channel to mute.

Selecting the full mute mode may be appropriate for applications where minimizing the chance of audio "leakage"

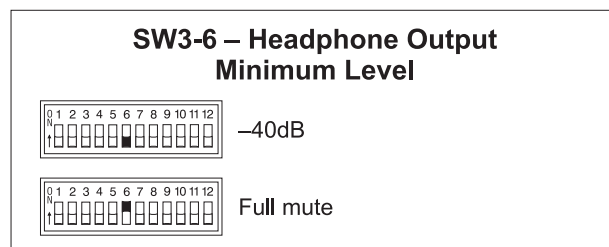

**Figure 12. Headphone output minimum level settings**

is important. This could occur when the connected headset or headphones are at times placed on a desk or tabletop.

### Digital Input Source

Switches SW3-7 and SW3-8 are used to select which one of the three digital interfaces will be used by the Model 212 as its audio source and reference clock input. The two audio channels associated with the selected digital input can be assigned to the headphone output channels. In addition, the clock signal derived from the selected digital input is used by the digital audio circuitry. This clock signal is the master “sync” reference that the Model 212 uses for the analog-to-digital conversion and digital audio transmission functions. The digital input interface choices are AES3id In, bidirectional digital interface, and AES3 In. As selecting the correct interface is critical to proper Model 212 operation it’s worth describing each in detail.

The AES3id input is located on the Model 212’s back panel and is compatible with unbalanced 75 ohm digital audio signals. This type of signal is common to broadcast facilities where audio and video utilize a common cabling-type and BNC connectors for signal transport. Note that many

people refer to this generically as an “AES” digital audio signal. But this is confusing and inaccurate as there are separate standards for 75 ohm unbalanced (AES3id) and 110 ohm balanced (AES) digital audio signals. (While the standards are separate, both share the same method of formatting the digital audio and control signals.)

The bidirectional digital interface is a special type of 75 ohm unbalanced signal that carries two channels of digital audio in each direction. To clarify, over a single unbalanced cable two channels of digital audio are sent in one direction and two channels of digital audio are sent in the other. The bidirectional digital interface uses a BNC connector which is located on the Model 212’s back panel. The interface is only appropriate for use in carefully engineered systems that are compatible with this type of signal. An example application is where a Model 212 is directly interfaced with a 75 ohm port on a Riedel digital matrix intercom system.

AES3 input circuitry is located inside the Model 212’s enclosure and is compatible with balanced 110 ohm digital audio signals. This type of signal is typically found in non-broadcast applications where the use of twisted pair wiring with a maximum interconnection length of 100 meters does not pose a problem. The Model 212 provides AES3 input circuitry for installer-selected applications where the desired connector is mounted into one of the spare connector locations on the Model 212’s back panel. Many applications use standard 3-pin female XLR-type connectors for AES3 inputs. However, using other connector types, such as Neutrik EtherCon, can be a convenient way of transporting a number of different signals over “CAT5” or “CAT6” twisted-pair cable.

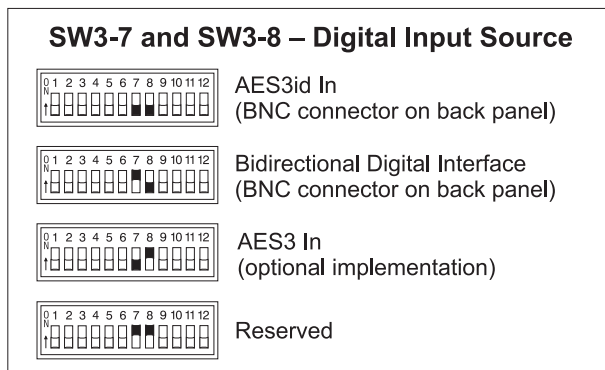
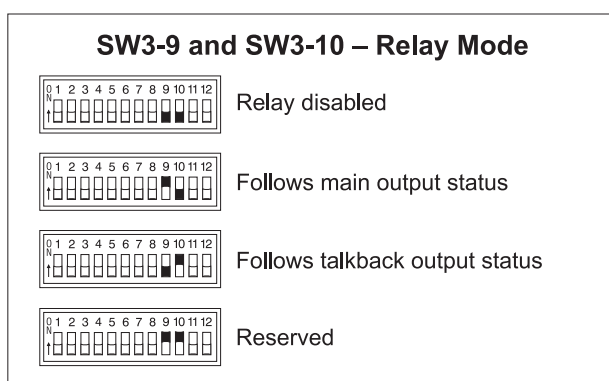

**Figure 13. Digital input source settings**

Incorrectly setting the digital input source will probably prove to be the most common cause of incorrect Model 212 operation. Carefully reviewing the connected signals and then selecting the appropriate interface will lead to successful operation.

### Relay Mode

Switches SW3-9 and SW3-10 are used to configure the operating mode of the auxiliary relay.



**Figure 14. Relay mode settings**

Three modes are available:

- **Relay is disabled:** In this mode the relay is disabled and will never change state.
- **Follows main output status:** In this mode the relay will follow the state of the main output channel. Specifically, the relay will change state (energize) whenever the main output channel is active.
- **Follows talkback button status:** In this mode the relay will follow the state of the talkback output channel. Specifically, the relay will change state (energize) state whenever the talkback output channel is active.

### System Modes

Switch SW3-12 is used to configure the overall operating mode of the Model 212. Specifically, it determines how the main output channel operates vis-à-vis the talkback output channel. Understanding how the two modes impact overall system operation will ensure that correct operation and maximum usability will occur. When the on-air mode is selected, the main output channel will mute (minimum digital audio signal level or –infinity) whenever the talkback output channel is active. The LED indicators associated with the main output button will light accordingly. The on-air mode should be selected for all on-air broadcast applications. It's imperative that the main output channel be muted whenever on-air talent uses the talkback output channel to communicate with production personnel.

When the system mode is set for production, the main output channel is never muted in response to the talkback output channel being active. In this way the main and talkback output channels can be used independently, with neither impacting the other. An example of where this would be useful is allowing the Model 212 to provide two independent talkback functions; the main and talkback buttons can be used independently or simultaneously. The production mode can prove very useful when selected for the correct application, but it's not appropriate for on-air use!

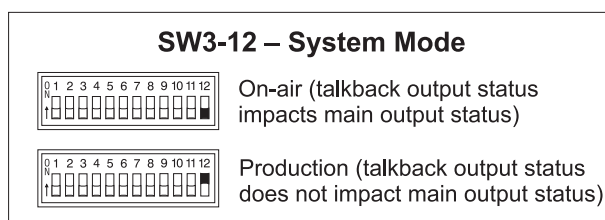

**Figure 15. System mode settings**

## Conclusion

Once the multitude of DIP switches have been set to their desired configuration, the security plate should be reattached. The four rubber bumpers should be hand-tightened only. No tools should be used.

## Operation

At this point the desired input, output, and power connections should have been made. The button labels may have been revised. Finally, the configuration switches should have been set. Normal operation of the Model 212 can now begin. The unit will begin functioning as soon as the source of nominal 24 volts DC is connected.

Upon Model 212 power up, the three status LEDs will light in succession as a firmware “boot up” indication. The unit will then begin normal operation. Depending on the selected configuration, one LED associated with the status of the main output may be lit. The user is now presented with two buttons, three LEDs, and two rotary controls. These are simple to operate and understand, as will be described in the following paragraphs.

## Pushbutton Switches and Status LEDs

Two pushbutton switches are used to control the main and talkback output channels. The way each operates depends on the selected configuration. Three LED indicators are located adjacent to the buttons. They reflect the status of the main and talkback output functions.

## Main Output Button and LED Indicators

The button on the left, factory labeled as COUGH, functions according to the selected configuration. Two LED indicators, located directly above the button, are associated with the status of the main output channel. The green LED, located on the right, is lit whenever the main output channel is active. This could be considered as an “on-air” or mic active indicator. At the least it should serve as a “careful what you say” warning! If the Model 212’s system mode is configured to on-air, the red LED, located on the left, will be lit when the main output channel is muted. This indicates that it’s safe to speak as one sees fit.

If the Model 212’s system mode is configured to production, the red LED will never light. This is to reflect the fact that the main output button has now taken on a function similar to that of the talkback output button. To clarify, when the Model 212 is set to the production mode, the red LED will never light; the green LED will light whenever the main output channel is active.

## Main Output Button Modes

- **Push to mute:** If this mode is selected the main output channel is normally active. The main output channel will mute whenever the button is pressed and held.
- **Push to talk:** If this mode is selected the main output channel is normally muted. The main output channel will become active whenever the button is pressed and held.
- **Alternate action:** If this mode is selected the main output channel will alternate between its active and muted states whenever the button is pressed. Upon power up the main output channel will be in its muted state.

- **Hybrid:** This mode is a combination of push to talk and alternate action. It's similar to the way talk buttons function on user stations associated with broadcast or production intercom systems. If the button is pressed and held, the main output channel will become active until the button is released. If the button is momentarily "tapped" the main output channel will change state. Upon Model 212 power up the main output channel will be in its muted state.

### **Main Output vis-à-vis Talkback Activity**

This short section applies only to the case where the Model 212's system mode is configured for on-air and the main output button mode is set to alternate action or hybrid.

Talkback activity will always cause the main output channel to be placed in its off state. If the main output channel was in the "latched" on state when talkback began, once talkback activity ends that state will resume; the main output channel will again be in its on ("latched") state.

### **Talkback Output Button and LED Indicator**

The button on the right, factory labeled TALKBACK, controls the talkback output channel. The manner in which the talkback button functions depends on the way it was configured. One LED indicator, green in color, is located directly above the talkback button. It lights whenever the talkback output channel is active. If the Model 212's system mode is selected to on-air, whenever the talkback function is active the main output channel will be placed in its muted state. If the Model 212 is selected to the production mode, the status of the talkback output channel will not impact the main output channel.

### **Talkback Output Button Modes**

- **Push to talk:** If this mode is selected the talkback output channel is normally muted. The talkback output channel will become active whenever the button is pressed and held.
- **Hybrid:** This mode is a combination of push to talk and alternate action. If the button is pressed and held, the talkback output channel will become active until the button is released. If the button is momentarily "tapped" the talkback output channel will change state. Upon Model 212 power up the talkback output channel will be in its muted state.

### **Headphone Output Level Controls**

Two rotary controls ("pots") are located on the Model 212's front panel and are associated with the headphone output. The way the controls function depends on the selected configuration. One configuration parameter sets the controls to operate in a level/level or a level/balance mode. Another parameter allows the left/right assignment of the controls to be reversed. A third parameter selects whether the headphone output channels will maintain a minimum output level or can be fully muted.

### **Level/Level Mode**

When set to the level/level mode, the two controls operate independently. Each control sets the output level of one channel of the stereo headphone output. If configured to the normal mode, the control on the left side is used to adjust the level of the headphone output's left channel. The control on the right is used to adjust the level of the right channel. If configured to the reverse left/right mode, the control on the left side adjusts the headphone



output's right channel. The control on the right adjusts the left channel.

When in the level/level mode, and the minimum output level is set for -40 dB, turning each control to its fully counterclockwise position will place its respective output level 40 dB below its maximum. This setting ensures that talent will never be fully "isolated" from potentially important cue signals. If present on the Model 212's input and assigned to the headphone channels, some audio signal will always be present on the headphone output. If set to the full mute mode, turning each control to its fully counterclockwise position will cause its respective output to fully mute.

Each level control has a mechanical step (detent) that is located at the halfway (50%) position of its rotation range. This is intended to serve as an aid to Model 212 users. In an ideal installation, setting the controls to their detent position will result in a comfortable headphone output level. The user, in response to a changing operating environment, can then move the level controls to get more or less level as desired. The detent position will always remain as a useful reference point. To achieve this condition the audio levels on the selected cue sources would have to be adjusted as required. This is somewhat counter to the usual mentality of just providing the user with whatever level comes up by default. Spending a few extra minutes "trimming" the audio levels can result in much happier, and more productive, talent.

### **Level/Balance Mode**

When set to the level/balance mode, the two controls operate together to adjust the desired headphone output level. The

control on the left adjusts the overall level of both the left and right channels. The balance control, located on the right, adjusts the relative left/right level balance. In this mode the controls operate in a manner reminiscent of a consumer audio amplifier or receiver. If set to the normal mode, rotating the balance control in the counterclockwise direction reduces the level of the right channel providing the user with more perceived level in the left channel. If set to the reverse mode, rotating the balance control in the counterclockwise direction reduces the level of the left channel providing the user with more perceived level in the right channel.

When in the level/balance mode and the minimum output level is set to -40 dB, turning the level control to its fully counterclockwise position will place both headphone output channels to 40 dB below maximum. This ensures that talent will never be fully "isolated" from potentially important cue signals. In addition, rotating the balance control to either its fully clockwise or fully counterclockwise position will cause the applicable channel to be 40 dB below its maximum. If set to the full mute mode, turning the level control to its fully counterclockwise position will cause both the left and right channels to fully mute. In addition, rotating the balance control to either its fully clockwise or fully counterclockwise position will cause the applicable channel to fully mute.

Each control has a mechanical step (detent) that is located at the halfway (50%) position of its rotation range. The balance control will typically be set to its center, detent position, making the level of the left and right channels equal. In an ideal installation, the level control can also be set to its detent position and provide a

comfortable headphone output level. This will allow the user, in response to their preference or a changing environment, to adjust the level and balance controls as desired. The detent positions will always remain as a useful reference point. To achieve this condition the audio level on the connected sources must be adjusted as required. Spending a few extra minutes “trimming” the connected audio signals, rather than just providing whatever happens to come up, should prove worthwhile. The result will be talent that is more relaxed, and an overall production that works more smoothly.

## Technical Notes

### Model 44 Interface

Some applications may benefit from using the Model 44 Interface which is also available from Studio Technologies. The single-rack-space unit provides operating power and digital audio interconnection for up to six Model 212 Announcer's Consoles. Each Model 212 interconnects with an RJ45 port on the Model 44 using a single 4-pair “CAT5” or “CAT6” Ethernet-style cable. One pair of the twisted-pair cable supplies 24 volts DC to the Model 212. Two additional pairs transport digital audio to and from the Model 212's AES3 interface. A fourth pair is available for installer-specified functions. Details about the Model 44 are available on the Studio Technologies website.

The EtherCon® Connector Card Kit (Studio Technologies, Inc. part number 31207) offers a simple means of preparing a Model 212 for use with a Model 44 Interface and Ethernet-style interface cables. This optional card kit is intended to be mounted in one of the two spare

connector openings located on the Model 212's back panel. It's recommended that, when viewed from the back, the EtherCon kit be mounted on the left side with the metal locking tab facing to the left.

Three jumper cable assemblies, provided with the EtherCon kit, are used to link the Model 212 with the appropriate pairs on the EtherCon connector. The Model 212's AES3 output is accessible on 3-pin header P8 and should be connected to 3-pin header P14 on the EtherCon kit's printed circuit board. The Model 212's AES3 input is accessible on header P9 and should be connected to header P15 on the EtherCon kit's printed circuit board. The Model 212's power input is accessible using header P10 and should be connected to header P13 on the EtherCon kit's printed circuit board.

Once this has been completed standard computer-style patch cables can be used to link the Model 212 with a port on the Model 44 Interface. These cables, often called “CAT5” patch cables, are “straight through” and organize their four twisted pairs as pins 1 and 2, pins 3 and 6, pins 4 and 5, and pins 7 and 8. For reference the EtherCon Connector Card Kit implements this interconnection scheme: pins 1 and 2 carry digital audio to the Model 44, pins 3 and 6 bring digital audio from the Model 44 to the Model 212, and pins 7 and 8 bring 24 volt DC power from the Model 44 to the Model 212. The power is polarity sensitive with positive on pin 7 and negative on pin 8.

### Phantom Power

The Model 212 provides a 48 volt nominal source of “phantom power” to support condenser-type microphones. It's designed to meet the P48 requirements

as specified in the IEC 61938 standard. The required circuitry is very simple: two 6.81 k ohm resistors provide a path from a 48 volt source to pins 2 and 3 of the microphone input connector. The resistors and the power source work together to provide 48  $\pm$ 4 volts, up to a maximum current of 10 milliamperes.

## LED Colors

As previously described, two LED indicators are associated with the main output and are located directly above the main output pushbutton switch. The red LED, located on the left, is lit whenever the main output channel is muted. The green LED, located on the right, is lit whenever the main output channel is active. The thought behind the color choices was that red would relate to the main output channel being muted (“stop”) while green would relate to the main output channel being active (“go”). It’s possible that these color choices may not meet the needs of all users and applications. For example, it’s reported that one European broadcaster typically uses these two colors in the opposite fashion. Their choice is to have the red LED lit whenever the main output channel is active, warning the talent that they are “on-air.” The green LED is lit whenever the main output channel is muted, indicating to the talent that it’s “safe” to say whatever they wish, about whomever they wish to say it about!

For consistency, the LED associated with the talkback button was selected to be green. This lights whenever the talkback channel is active. It’s possible that some applications may benefit from revising this LED color too. While red is certainly one possible choice, other colors are also a possibility including amber, orange, or

blue—these days there are lots of choices available. The only limitation is the amount of current available to light each LED. Using series resistors of no less than 560 ohms will ensure correct Model 212 operation.

A qualified technician can easily revise the LED colors to meet an application’s exact needs. The process would begin by disassembling the Model 212’s enclosure and detaching the pushbutton/LED printed circuit board assembly. The LEDs would then be unsoldered, removed, and reinstalled (or replaced) in the desired locations. To control the LED current and set the brightness, a resistor is electrically in series with each LED. From the factory, an 820 ohm, 1/4-watt resistor is associated with the red LED while a 560 ohm, 1/4-watt resistor is associated with each green LED. These resistors would also have to be unsoldered, removed, and reinstalled. Then the unit would be reassembled and tested to confirm that the changes function as desired.

For additional information about changing the LED colors, please contact Studio Technologies’ technical support.

## Travel Case

For portable applications it may be desirable to store and transport each Model 212 in a protective case. After much travel with prototype announcer console units, Studio Technologies’ personnel learned to appreciate the Pelican Model 1450 case. Purchased with the foam interior option, it does an excellent job of holding one Model 212, its associated 24 volt DC power supply, and documentation. Some applications may benefit from selecting a larger case that would also hold a related headset, cables, etc. A larger case could

also be selected that would hold multiple Model 212 units. Pelican sells their products through a dealer network, many of which can be located via a web search.

## Connecting Analog Inputs

The Model 212 is designed to directly connect with digital audio signals. However, there may be applications where it would be useful to also be able to connect analog line-level audio sources. To facilitate this one or two line input cards can be installed. They are mounted into the spare connector locations that are provided on the Model 212's back panel. Two types of line input cards are available from Studio Technologies and are purchased separately. One card contains passive circuitry, including a 3-pin female XLR-type connector and a 10 k ohm to 10 k ohm isolation transformer. Once installed, balanced or unbalanced line-level audio sources can be directly connected. The second type of card contains an identical connector and isolation transformer circuit, followed by a sophisticated VCA-based limited circuit. This arrangement helps prevent abnormally large signal levels from reaching the headphone output channels.

Each line input card kit contains a printed circuit board assembly, the required interconnecting cables, and hardware. To install the kit is very simple. The XLR-type connector is mounted into one of the spare connector locations on the Model 212's back panel. This secures the connector and associated printed circuit board to the enclosure. The interconnecting cables are then used to link the card with the Model 212's main printed circuit board assembly.

For balanced audio sources the mating connector (3-pin male XLR-type) should be wired so that signal high (+ or hot) is connected to pin 2, signal low (– or cold) is connected to pin 3, and shield is connected to pin 1. Unbalanced sources should be wired so that signal high is on pin 2, and signal low/shield is connected to both pins 1 and 3. If this results in hum on the input, try connecting signal high to pin 2, signal low/shield to pin 3, and pin 1 left unterminated (“floating”).

Several things are worth mentioning when it comes time to actually using a line input card. The input is transformer coupled with a nominal input impedance of 10 k ohms. Capacitors in series with the transformer's primary provide protection against accidental connection to a signal that has DC voltage present on it. The nominal input level is +4 dBu but should work correctly with signal levels down to nominal –10 dBu.

Note that if one or two line input cards are installed in a Model 212, both analog line-level audio signals and a digital audio circuit can be connected at the same time. The audio sources will be routed to the headphone outputs by way of the headphone source configuration switches. Each of the four possible audio sources can be routed to the left-headphone output, the right-headphone output, or both headphone-output channels. Details on how to use these switches are provided in the Configuration section of this user guide.

## Additional Connectors

Two spare connector locations are provided on the Model 212's back panel. From the factory they contain blank plates that can be readily removed and replaced with

a variety of XLR-type connectors. These spare connector locations are specifically included so that a Model 212 can be customized to meet the many specific needs that arise in broadcast and related audio applications. Expected uses for these locations include adding a 5-, 6-, or 7-pin XLR-type connector to allow direct connection of a broadcast headset. In addition, Studio Technologies offers optional line input cards that mount directly in a spare connector location. This was previously described in this user guide.

The spare connector locations are compatible with the Neutrik DL-series of connectors. For flexibility, versions are available that provide from three to seven contacts. For example, a compatible 3-pin female connector would be Neutrik part number NC3FD-L-1. To support headsets the NC6FDS-L-1 is often used. This is a 6-pin female connector with the unique Switchcraft® 6-pin arrangement. The hardware that secures the blank plates to the Model 212's back panel is also intended to secure the replacement connectors.

If connectors are installed in the Model 212's spare connector locations adding labels to those connectors can be helpful. For a great look it is recommended that Brother® P-Touch ¼-inch (6 mm) labels be created. Tape material that prints white text on a black background works out well for the Model 212. The Brother label cassette number TX-3151, white on black, is appropriate for use with many of their printers.

In addition to the spare connector locations on the back panel, provision has been made to allow easy interconnection with the Model 212's printed-circuit-board-mounted input and output connectors.

This was accomplished by including numerous 3-position male "header" connectors on the Model 212's circuit board. These headers, on 0.1-inch centers, are wired in parallel with the Model 212's connectors. This "no solder" solution makes customizing a Model 212 a simple process. The headers, located on the Model 212's printed circuit board, are Molex® part number 22-23-2031. They mate with Molex housing number 22-01-3037. To make the interconnection separate crimp terminals are attached to loose wires and then "snapped" into the housing. Molex part number 08-50-0114 specifies crimp terminals that are appropriate for wires of 22 to 30 gauge. These parts are available worldwide from sources such as Digi-Key ([www.digikey.com](http://www.digikey.com)).

To make the process of connecting to the Model 212's headers a simple task an interface cable kit, part number 31087, is available from Studio Technologies. Each kit includes five cable assemblies and a length of heat-shrinkable tubing. Each cable assembly consists of a mating connector with three color-coded wires attached. These wires, nominally 12 inches in length, allow convenient soldering to a connector selected to be installed in a spare location on the Model 212's back panel. For reference, the wire color for pin 1 is gray, pin 2 is yellow, and pin 3 is blue.

The heat-shrinkable tubing is provided so that connector solder cups can be insulated from each other. It will also provide some strain relief to the solder joints. Be certain to slip the desired length of tubing over the wire prior to soldering a connection! (If the writer had a dollar for every time he forgot to put tubing on a wire—or slip on a connector shell—before making a solder connection...)

The Model 212's enclosure must be disassembled prior to installing connectors in the spare locations. Four hex-head machine screws, two on the bottom front of the enclosure and two on the back panel, must be removed. A 5/64-inch hex driver is required. The cover can then be carefully separated from the chassis, remaining attached by means of a flexible cable assembly. This "flex-cable" assembly links the main printed circuit board assembly with the board assembly that contains the pushbuttons and LED indicators. Ensure that the flex cable is not damaged while the Model 212 is being customized. For easier access, the pushbutton/LED board assembly can also be easily removed.

The 3-position headers on the Model 212's main circuit board assembly are generally located close to their related input or output connectors. The following list provides the printed circuit board reference numbers and associated functions:

- P1:** AES3id input, pin 1 floating, pin 2 signal, pin 3 shield.
- P2:** Bidirectional Digital Interface, pin 1 floating, pin 2 signal, pin 3 shield.
- P3:** External 24 volt DC input, pin 1 common, pin 2 +24 volts, pin 3 not used. Note: header P10 is used by the back-panel 24 Vdc jack assembly and is electrically in parallel with P3.
- P4:** Headphone output, pin 1 common, pin 2 left (tip), pin 3 right (ring).
- P5:** Microphone input, pin 1 shield, pin 2 high, pin 3 low. Note: follows back-panel 3-pin female XLR pin assignment.
- P7:** AES3id output, pin 1 floating, pin 2 signal, pin 3 shield.

Additional functions can be accessed using these 3-position headers:

- P6:** Auxiliary relay contact B, pin 1 normally closed, pin 2 common, pin 3 normally open.
- P8:** AES3 output, pin 1 common, pin 2 high, pin 3 low.
- P9:** AES3 input, pin 1 common, pin 2 high, pin 3 low.
- P11:** Auxiliary relay contact A, pin 1 normally closed, pin 2 common, pin 3 normally open.
- P12:** Auxiliary input 2, pin 1 common, pin 2 unbalanced analog audio, -10 dBu nominal, pin 3 not used.
- P13:** Analog mic output, pin 1 common, pin 2 unbalanced analog audio, -15 dBu nominal, pin 3 not used.
- P14:** Auxiliary input 2, pin 1 common, pin 2 unbalanced analog audio, -10 dBu nominal, pin 3 not used.
- P15:** Pushbutton backlighting, pin 1 common, pin 2 button lamps, pin 3 current limited 24 volts from external 24 volt DC input.
- P17:** Remote switch connections, pin 1 common, pin 2 main output control, pin 3 talkback output audio.

## Pushbutton Backlighting

For special applications, provision has been made to allow illumination ("backlighting") of the two pushbutton switches. This may prove useful for applications where adequate room lighting is not available. It can also serve in custom Model 212 configurations. Note that this is an advanced feature, intended only to be implemented by a qualified technician.

From the outset several limitations must be discussed. The first is that button backlighting is not intended to serve tally applications. (A common connection to power both lamps is provided; independent access to the lamp connections on each button is not provided.) It is strictly intended to provide a moderate amount of illumination to the button's clear lens and associated labeling. The second restriction is that power for the backlighting function is in addition to the 150 milliamperes required for normal Model 212 operation. This should not prove to be a problem as the lamps only add approximately 40 milliamperes. But it must be taken into account when determining if the power source can support the increased load.

From the factory, lamps ("bulbs") are not installed in the pushbutton housings. They are pluggable T-1 bi-pin type and are simple to install. The mating socket is accessed by removing the button's lens caps, graphic label, and back frosted lens. Compatible incandescent lamps with a nominal rating of 18 volts, 28 mA are available from Studio Technologies (part number 12030). Bulbs with other nominal voltages should also be available from electronics parts vendors. While compatible LED-based lamps are probably also available, incandescent lamps, when powered below their rated current and voltage, can provide extremely long and reliable operation.

A 3-position header connector, labeled P15, is located on the Model 212's main printed circuit board. It provides access to, and a means to power, the two lamps. Pin 1 of the header is connected to the common point of the Model 212's circuitry, which is also connected to one contact on

both lamps. Pin 2 of the header is connected to the other contact on both lamps. Pin 3 is connected, by means of a current limiting resistor, to the external 24 volt DC source. If lamps were obtained from Studio Technologies then adding a "jumper" from pin 2 to pin 3 is all that is required to get things going. A standard 0.1-inch-center jumper, commonly used on electronic equipment, is all that is required. A 390 ohm, 1 watt resistor is electronically in series between the external 24 volt DC input and pin 3 of the header. When used with the lamps available from Studio Technologies, the resistor limits the lamp current to approximately 40 mA. This lights the lamps to a moderate intensity. If a different type of lamp is installed, its power source should be connected to pins 1 (common) and 2 (lamps) of the header.

## Remote Control Connections

Provision has been made on the Model 212's printed circuit board assembly to allow external switches or contact closures to control the main output and talkback output functions. A 3-position header, labeled P17, provides access to the circuitry associated with the functions. Pin 1 of the header is connected to the common point of the Model 212's circuitry. Pin 2 of the header is connected to the circuitry associated with main output pushbutton. Pin 3 of the header is connected to the circuitry associated with the talkback output pushbutton. The input circuitry is "active low," with a 10 k ohm resistor connected to +5 volts acting as a pull up. A combination of resistors and capacitors provides ESD protection. A qualified technician can use these inputs for special applications. Contact the factory for additional details.

## Digital Audio Outputs

As has been previously discussed in this user guide, the Model 212 is capable of supporting three digital audio outputs. Directly accessible on the back panel are the BNC connectors for the AES3id output and the bidirectional interface. Accessible internally for installer-selected applications is the AES3 output. It's important to mention that these three outputs are always active, each sending out the identical digital audio and control bit stream. While most applications will use only one of the outputs, there's no reason why two, or all three, can't be utilized.

In addition, while the bidirectional digital interface is intended to send and receive data over a single cable, it can be used as a standard AES3id output. The only requirement is that the configuration for the digital input source must be selected for something other than the bidirectional digital interface. This ensures that a stable clock source will be available for the all the digital outputs.

## Channel Status Bits

Following the AES3 and AES3id standards, the Model 212 configures the channel status bits. The unit is defined as being a professional device, the sample rate is set to follow the actual sample rate, and the word length is 24 bits. These settings are made in the Model 212's software and cannot be changed in the field. This was specifically done to help ensure reliable operation in the field. The setting was carefully selected to allow reliable operation in all intended Model 212 applications.



# Specifications

## General Audio:

**Frequency Response:** < -0.1 dB at 20 Hz, -1 dB at 18 kHz, mic in/main channel out

**Distortion (THD+N):** 0.025%, measured at 1 kHz, mic in/main channel out

**S/N Ratio:** 71 dB, referenced to -46 dBu mic in/-14 dBFS out

**Common Mode Rejection Ratio:** 68 dB at 60 Hz

## Connectors:

**Mic In:** 3-pin female XLR-type

**AES3id Out, AES3id In, Bidirectional Interface:** 75 ohm BNC

**Headphone Out:** ¼-inch 3-conductor phone jack

**24 Vdc Power In:** coaxial power jack, 2.1 x 5.0 mm, locking bushing, compatible with Switchcraft S760K plug, center pin positive

## Spare Connector Locations: 2

Allows one or two Neutrik NC\*D-L-1 connectors to be installed (\*=3F, 3M, 5F, 5M, 6F, 6FS, etc.). Also compatible with Neutrik EtherCon.

## Digital Inputs/Outputs:

**A/D, D/A Converters:** 24 bit, 100 dB dynamic range

**Sampling Rate:** internal clock source 48 kHz, external clock source 32 to 96 kHz

**AES3id In:** unbalanced, transformer-coupled  
Impedance: 75 ohms  
Minimum Input Carrier Amplitude: 320 mVpp (SPDIF compatible)

**AES3id Out:** unbalanced, transformer-coupled  
Impedance: 75 ohms  
Output Carrier Amplitude (Loaded): 1 Vpp

**Bidirectional:** unbalanced transformer-coupled  
Impedance: 75 ohms  
Output Carrier Amplitude (Loaded): 1.75 Vpp  
Minimum Input Carrier Amplitude: 320 mVpp

**AES3 In:** balanced, transformer-coupled (via optional connector)  
Impedance: 110 ohms  
Minimum Input Carrier Amplitude: 200 mVpp

**AES3 Out:** balanced, transformer-coupled (via optional connector)  
Impedance: 110 ohms  
Output Carrier Amplitude (Loaded): 3.5 Vpp

## Microphone Input/Preamplifier:

**Type:** electronically balanced

**Input Impedance:** 2 k ohms, nominal

**Gain Range:** 10 to 50 dB, nominal, adjustable in 10 dB steps

**Compatibility:** dynamic or phantom-powered mics

**Phantom Power:** 48 Vdc, nominal, meets IEC 61938

## Compressor:

**Threshold:** -14 dBFS or -4 dBFS, switch selectable

**Attack/Release Time:** 2 mSec/100 mSec, nominal

**Slope:** 5:1, nominal

**Status LED:** compressor active

## Headphone Output: 1, stereo

**Compatibility:** intended for connection to mono or stereo headphones or headsets with nominal impedance of 100 ohms or greater

**Type:** voltage driver

**Maximum Output Voltage:** 8 Vpp, 150 ohm load

## Auxiliary Relay:

**Function:** software configurable

**Contacts:** 2, form C (Common, Normally Closed, Normally Open)

**Rating:** 1 A, 30 W (resistive)

**Access:** requires user-implemented connector scheme

## Power Source:

24 Vdc nominal, 150 mA max @ 24 Vdc; acceptable range 20-30 Vdc. Units shipped to North America and Japan include a 120 V input/24 Vdc output power supply. Units shipped to all other locations include a universal input/24 Vdc output power supply.

**Options:** one or two optional cards or connectors can be installed to provide support for connection of AES3, line-level balanced or unbalanced audio sources

## Dimensions (Overall):

5.6 inches wide (14.2 cm)

3.3 inches high (8.4 cm)

8.5 inches deep (22.4 cm)

**Weight:** 3.2 pounds (1.45 kg)

Features and specifications subject to change without notice.

# Appendix A

A label is attached to the security plate on the bottom of the unit. It provides a summary of the configurable parameters and related information. The actual label size 4.25 inches by 4.60 inches.

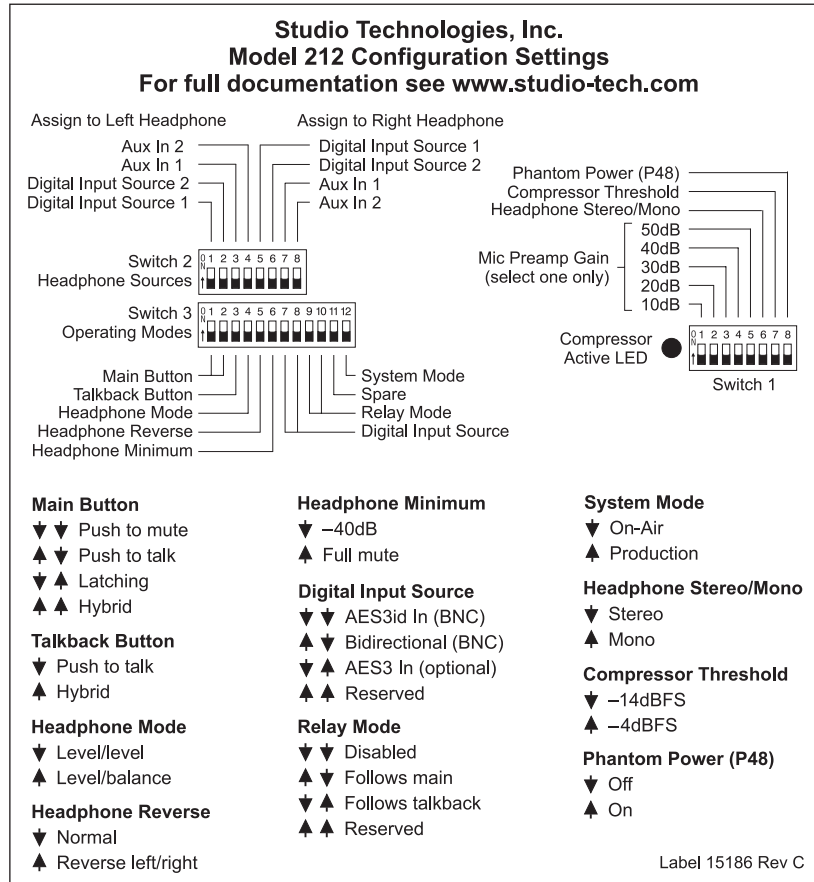

This page intentionally left blank.

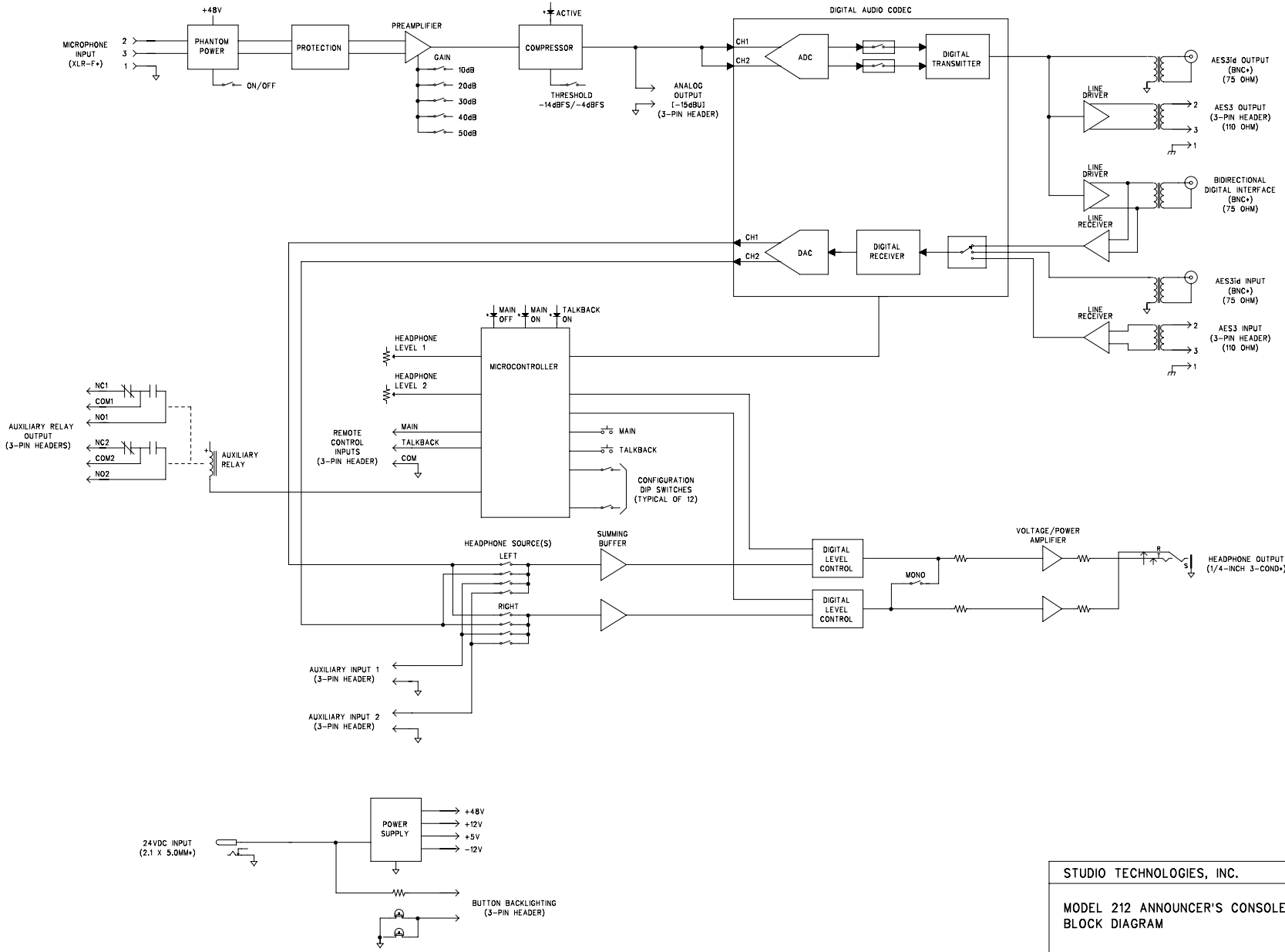

\* ALSO HAS 3-PIN HEADER IN PARALLEL ON PRINTED CIRCUIT BOARD

STUDIO TECHNOLOGIES, INC.		
MODEL 212 ANNOUNCER'S CONSOLE BLOCK DIAGRAM		
DRAWING NO.	DATE	PAGE
31184	07/28/05	01 of 01

M212BD\_A