

Model 230

Announcer's Console

User Guide

Issue 9, November 2014

This User Guide is applicable for serial numbers:
M230-01151 and later

Copyright © 2014 by Studio Technologies, Inc., all rights reserved

www.studio-tech.com

This page intentionally not left blank.

Table of Contents

Introduction	5
System Features	6
Installation and Setup	12
Configuration	17
Operation	28
Advanced Operation	33
Technical Notes.....	34
Specifications.....	48
Appendix A.....	49
Block Diagram	

This page intentionally not left blank.

Introduction

What This User Guide Covers

This User Guide is designed to assist you when installing, configuring, and using Model 230 Announcer's Consoles with serial numbers 01151 and later. Additional background technical information is also provided. A product block diagram is included at the end of this guide.

System Overview

The Model 230 Announcer's Console is designed to serve as the audio control "hub" for announcers, commentators, and production personnel. The tabletop unit is suited for numerous applications including on-air television and radio broadcasting. The Model 230 is compatible with essentially all broadcast and production audio system environments. Standard connectors are used to interface microphone, headphone, on-air, talkback, IFB, and party-line intercom signals.

Whether it's the mic preamplifier, audio switching, talkback signals, intercom interfacing, or headphone cue feed, superior audio quality is maintained throughout. A microprocessor provides the Model 230's logic power, allowing precise control of the unit's operation. With extensive flexibility built in, creating the desired operating configuration is a simple matter. While the operating features of the unit can be carefully tailored, the user is presented with an easy-to-use set of controls and indicators. A wide range of resources, great performance, and simplicity during use—these are the hallmarks of the Model 230.

A truly next-generation product, exhaustive research into the needs and desires of field production personnel was integral to the Model 230's creation. Providing a veritable "tool kit" of features, the unit supports a wide variety of applications that include on-air television and radio broadcasting, stadium announcement, and simultaneous interpretation. In addition, with the unit's



Figure 1. Model 230 front panel



Figure 2. Model 230 back panel

broad range of capabilities many other specialized “behind-the-scenes” applications can also be implemented.

System Features

Microphone Input

A high-performance microphone preamplifier circuit provides low-noise/low-distortion amplification over a 20 to 60 dB gain range. The gain is adjustable in 10 dB steps. The input is compatible with balanced dynamic and condenser microphones. The microphone power source is 48 volts nominal and meets the worldwide P48 phantom power standard. The preamplifier’s gain can also be set for 0 dB, allowing a line-level audio signal to be connected. This could provide useful in special applications such as when an external preamp or mic processor is being used.

An LED indicator serves as an aid for optimizing the preamplifier’s gain setting. The output of the microphone preamplifier is used by the main output as well as being routed to the compressor circuit that supports the talkback functions.

Main Output

The Model 230 provides a main output that is designed to serve as the on-air, stadium announcement, or other primary audio feed. Nominally -2 dBu, it is designed as a fully professional interface with high output capability, low distortion, and low noise. The output circuitry features a high-performance output transformer expressly designed for use in professional audio applications.

Talkback Functions

The talkback functions are intended to provide personnel associated with production trucks, control rooms, live-performance, and sports venues with talent-originated cue signals. The Model 230 contains two pushbutton switches that control the talkback functions. Each button can be configured to allow talkback audio to be routed to one of three locations: intercom channel 1, intercom channel 2, or a line-level talkback output. The line-level talkback output is transformer-coupled with a $+4$ dBu nominal signal level. It contains resistors in series with the output connector, allowing line-level talkback outputs from multiple units to be directly “summed.”

For non-on-air applications, the Model 230 can be placed in its “production” mode. This software-based mode allows the main output to be used as an additional talkback output. This feature makes the unit even more powerful when used in live-event applications, such as serving as a master console for an orchestra conductor or production director. With this flexibility, the exact needs of many specific applications can easily be met. And, of course, whatever configuration is selected the audio quality will be excellent.

Dynamic Range Control

To enhance the Model 230's talkback functions, a studio-quality compressor circuit is provided to control the dynamic range of the signal coming from the microphone preamplifier. Far from a simple “clipper,” the circuit utilizes a sophisticated laser-trimmed voltage-controlled-amplifier (VCA) integrated circuit for quiet, low-distortion level control. The signal from the compressor is used by the talkback functions. This ensures that talkback audio signals remain clear and intelligible under all real-world conditions. In addition, dynamic range control is especially important when talkback signals are being routed to party-line intercom channels.

User Controls and Status Indicators

Three pushbutton switches, four LED indicators, and two rotary controls provide the user with a clear, easy-to-use interface. One pushbutton switch controls the status of the main output. This is the audio output intended for on-air, announcement, or other primary uses. Two LEDs display the on/off status of the main output. Two additional pushbutton switches control the status of the talkback functions. These

functions create the audio cue signals used to communicate with producers, directors, “spotters,” or other behind-the-scenes production personnel. A status LED is associated with each talkback button. Two rotary controls allow the user to adjust the level of the headphone output.

Flexibility

A large part of the Model 230's unique power is the ability to configure the operation of the main output and talkback functions. To meet the needs of the many specific broadcast and production applications, a variety of button operating modes is available. The main output button can be selected to operate from among four modes. In the “push-to-mute” mode the button performs a momentary mute of the main output. In this way a “cough” button function is created, something typically required for television sports broadcasting. In the “push-to-talk” mode the button provides a momentary active function for the main output. This mode would be appropriate for applications such as stadium announcement. An alternate action “latching” configuration allows the button to enable or disable the main output as desired. This is useful in radio broadcasting, announce-booth, or voice-over applications. The fourth mode provides a hybrid function, supporting both push-to-talk and tap-to-enable/tap-to-disable operation. This operation is similar to that found in many broadcast intercom system user stations.

The two buttons associated with the talkback functions can be configured to operate from among two modes. One of the modes supports a “push-to-talk” function. This is typically used for on-air broadcast applications. The other mode provides a hybrid function, the operation of which is

discussed in the previous paragraph. The hybrid mode is especially useful when the Model 230 is used in a production-support application.

The main button mode configures how the main output, when it is in the “latched” on state, responds to talkback activity. One choice momentarily turns off the main output when talkback is active, returning the main output to the on state when the talkback function has ended. The other choice “unlatches” the main output in response to a talkback function.

IFB Input

A broadcast-standard “wet” (DC with audio) IFB circuit can be directly connected to the Model 230’s IFB input. Originated by sources such as the RTS™ 4000-series IFB system or IFB interface devices from Studio Technologies, the connected IFB circuit can provide DC power to operate the Model 230 as well as two channels of cue audio.

Cue Sources

The Model 230 supports the connection of up to six audio sources, each of which can be selected for routing to the stereo headphone output. The sources are IFB channel 1, IFB channel 2, line input 1, line input 2, intercom channel 1, and intercom channel 2. Each source can be individually assigned to the left channel, right channel, or both left and right. This allows a wide variety of stereo and mono headphone mixes to be created.

The two audio signals associated with the Model 230’s IFB input can be assigned to the headphone output. Originating in production trailers or control rooms, the IFB circuits typically provide DC power and program-with-interrupt audio on one channel and program-only audio on the other.

For application flexibility, two line-level audio sources can be connected to the Model 230. Possible signal sources include off-air receivers, wireless IFB systems, and audio consoles. The connected signals can be from two independent sources, or could be from a stereo audio feed such as would be associated with a broadcast music event. Two level trim potentiometers, located on the bottom of the unit, allow signals with wide nominal audio levels to be cleanly interfaced.

Audio signals associated with a single- or dual-channel party-line intercom system can be routed to the headphone output. The Model 230’s intercom interface is compatible with standard party-line intercom systems from manufacturers such as RTS and Clear-Com®.

Headphone Output

Two rotary controls are provided for user adjustment of the headphone output levels. For application flexibility the actual function of the two “pots” is configurable. For traditional on-air sports applications they can be selected to the dual level control mode which provides independent control of the left and right channel volume. For use with stereo cue signals, or to support user preference, the level/balance mode can be selected. In this mode one control adjusts the overall level of both the left and right channels, while the other allows adjustment of the left/right level balance. To help minimize the chance of broadcast cues being missed, both level control modes can be configured so that a minimum headphone output level is maintained. Alternately, the headphone output can be set to fully mute when the controls are at their minimum position.

A headphone control reverse mode is provided specifically for on-air television applications where a headset with boom microphone is used. The reverse mode ensures that no matter which headset orientation is used by the talent, the controls will always work intuitively. This results in a comfortable work environment, allowing the left control to impact the level to the talent's left ear while the right control impacts the right.

Provision has been made to support applications where a monaural cue feed is desired. A configuration switch allows the summing (combining) of the selected left and right headphone sources. In addition to creating a dual-channel mono output it also allows the level controls to be configured as a simple 2-channel mixer. For applications where a single "muff" headset or IFB earpiece is connected, another configuration switch can be used to disable the headphone output's right channel.

The headphone output is optimized to meet the needs of contemporary headphones and headsets. Specifically, the output circuits act as voltage, rather than power, drivers. In this configuration they can provide high output levels with very low distortion and noise, along with minimal current consumption. The output circuits are configured to safely drive stereo or mono loads. This ensures that all types of headphones, headsets, and earpieces can be directly connected.

Intercom Interface

Of special note is the Model 230's sophisticated party-line intercom interface. It's designed to work correctly with industry-standard single- and dual-channel party-line intercom systems, including those from RTS and Clear-Com. An intercom

line connected to the Model 230 can serve three functions: providing cue audio signals to the headphone output, allowing talkback audio to be sent to intercom users, and as a Model 230 power source. Audio signals present on the single- or dual-channel intercom line can be flexibly routed to the headphone output. Talkback audio can be sent to either or both intercom channels. Trim potentiometers, located on the bottom of the unit, allow adjustment of the talkback-to-intercom null ("sidetone") level.

The ability to listen to one or both pins of a connected intercom circuit will only be available when the intercom interface circuit detects DC voltage on pin 2. This feature minimizes the chance that objectionable audio content (i.e., "howls" or "squeals") will be routed to the headphone output when an intercom circuit is not connected.

Sidetone Function

The Model 230 includes a sidetone function that routes audio from the microphone input to the headphone output as a user confidence signal. This allows a user to always hear what they are saying, a critical requirement for effective communications. The sidetone level can be adjusted using one of the front panel level controls, allowing the user to set it as required for effective use.

Audio Quality and Protection

The Model 230's circuitry is carefully tailored to provide excellent audio performance. Professional-quality components are featured throughout. For reliability all audio routing is performed using solid-state devices under microcontroller direction. In all critical audio paths, "clickless" electronic switches provide noise-free

control. All audio inputs and outputs make extensive use of protection components. This limits the chance of damage from ESD and other undesirable, yet real-world, hazards.

Power Sources

The Model 230 can derive its operating power from an IFB circuit, an intercom line, or an external 24 volt DC source. For redundancy, all three power sources can be connected simultaneously. An internal switch-mode power supply ensures that all Model 230 features are available, including phantom power, when the unit is powered by any of the three sources.

The Model 230 is compatible with IFB circuits provided by most standard broadcast systems. However, maximum performance can often be obtained by using IFB interface devices available from Studio Technologies. They provide high-quality audio signals along with an excellent source of DC power. They are directly compatible with most matrix intercom systems, as well as standard line-level audio signals. Refer to the Studio Technologies website for details.

Auxiliary Relay

Model 230 resources include a general-purpose relay, allowing specialized configurations to be created. Under software control, the relay can be configured to follow the state of the main output, talkback 1, or talkback 2 buttons. Taking advantage of the back-panel locations provided for additional XLR connectors, a technician may easily implement a variety of functions such as an “on-air” indicator or performing loudspeaker muting during talkback. Special configuration modes are even included to allow direct control of the

relay using the talkback 1 or talkback 2 buttons without impacting any of the unit’s audio signals.

Configuration

Model 230 configurations are made using a number of DIP switches and four trim potentiometers. One 8-position switch assembly is used to set the gain of the microphone preamplifier, the on/off status of phantom power, and control of the headphone output modes. A 12-position switch assembly configures which of the six cue audio sources are routed to the headphone outputs. Two 8-position switch assemblies communicate the desired operating modes to the microprocessor. Two rotary trim pots are used to adjust the input sensitivity of the line inputs. Two additional rotary trim pots are provided to adjust the “sidetone” level for the intercom interfaces’ talkback functions. All switches and trim pots are accessible via the bottom of the Model 230’s enclosure; the unit does not have to be disassembled. Changes made to any of the configuration parameters become active immediately. To prevent access to the configuration controls a security plate, included with each unit, is attached to the bottom of the enclosure.

Connectors

The Model 230 uses standard connectors throughout. The microphone input, line inputs, IFB input, and intercom interface functions use 3-pin female XLR connectors. The main output and line-level talkback output functions use 3-pin male XLRs. The headphone output utilizes a ¼-inch 3-conductor jack. The external source of 24 volt DC power is connected by way of a 2.1 x 5.5 mm “locking” coaxial power jack.

Additional Connector Locations

In the world of broadcast and production audio it's fair to say that applications vary widely. To this end, up to three additional XLR connectors can be easily mounted into the Model 230's back panel. Multiple 3-position "headers" located on the Model 230's circuit board provide technician-access to literally every input and output connection. Using a factory-available interface cable kit, these allow a Model 230 to be optimized to meet the exact needs of specific applications. For example, some applications may prefer to use a multi-pin XLR connector to interface with a headset. This could be easily accomplished by adding the appropriate 5-, 6-, or 7-pin XLR connector and making a few simple connections. Other applications may benefit from having "mult" or "loop-through" connections, something easily incorporated into a Model 230.

Multi-Pin Headset Connectors

As previously mentioned, some broadcast applications use headsets that interface using a multi-pin connector. In most cases these connectors are 6- or 7-pin male XLRs wired to an industry-standard pinout scheme. Studio Technologies offers headset connector assemblies that allow fast and painless installation into a spare connector location in the Model 230's back panel. Details about these optional assemblies are available on the Studio Technologies website.

Options

The Model 230's standard resources are more than sufficient to directly support a large number of applications. But in the "real world" of audio and intercommunications special needs always seem to arise. To that end, Studio Technologies offers

a number of option cards. In addition to passive or active components, each card contains an integral connector, allowing simple installation into a spare connector location on the Model 230's back panel. For interest, the resources provided by some of these option cards are worth describing.

- The direct microphone output card provides access to the dynamic or condenser microphone that is connected to the Model 230's mic input. Passive components, along with the auxiliary relay contact, create a "click-free" microphone-level audio signal.
- The line output card allows the Model 230 to provide a second line-level talk-back output.
- The remote switch input card uses a 4-pin XLR connector to provide access to the Model 230's remote switch inputs.
- The tally/remote switch input card provides a current-limited DC voltage that serves as a main output status signal. It also provides a remote switch input connection.

Other general purpose option cards provide 3-pin XLR, 4-pin XLR, and 8-pin EtherCon® connectors. With the range of option cards available it's hard to imagine an application that can't be served. But you're welcome to try to "stump the chumps" in the Studio Technologies technical support department! But first please check the complete list of the available option cards listed on the Studio Technologies website.

200-Series Announcer Console Products

The Model 230 is just one in a series of announcer console products available

from Studio Technologies. The Model 230 was designed to support a variety of applications where a wide range of features and flexibility is required. For applications whose requirements are either greater or more limited in scope, other products in the 200-series should be reviewed. Complete information is available on the Studio Technologies website.

Installation and Setup

In this section interconnections will be made using the input and output connectors located on the Model 230's back panel. Microphone, main output, line-level talk-back output, line-level audio sources, IFB, and party-line intercom signals are interfaced by way of 3-pin XLR connectors. A ¼-inch 3-conductor phone jack is provided for the headphone output. A 2.1 x 5.5 mm coaxial jack allows connection of an external 24 volt DC power source.

System Components

Included in the shipping carton are the following: Model 230 Announcer's Console, user guide, button label sheet, and 24 volt DC power supply.

Microphone Input

The Model 230 is compatible with balanced dynamic and condenser microphones. Depending on the application, the microphone may be part of a headset, or be an independent handheld or stand-mounted model. The Model 230's 48 volt nominal power source will support essentially all phantom-powered microphones. The quality of the Model 230's microphone preamplifier and associated circuitry is such that special applications may benefit from using

“high-end” microphones. If selected appropriately, models from manufacturers such as AKG, Beyer, Neumann, Sennheiser, and Shure will perform very well in Model 230 applications.

The microphone input is also compatible with line-level audio sources. This allows the output of an external microphone preamplifier, microphone processor, or audio console to be directly connected. When the configuration DIP switches are set for 0 dB (no gain) the nominal level of the source audio signal should be approximately -2 dBu.

Microphone interconnection is made by way of a 3-pin female XLR connector which is located on the Model 230's back panel. The mating connector (male) should be wired so that pin 2 is signal high (+ or hot), pin 3 is signal low (- or cold), and pin 1 is shield. It's possible that an unbalanced microphone will also work correctly. In this case, the mating connector (male) should be wired so that pin 2 is signal high (+ or hot), and signal common/shield is connected to both pins 1 and 3.

The Model 230 is not compatible with unbalanced “electret”-type microphones that require a source of low-voltage DC for operation. These microphones, sometimes found in low-cost headsets, are not generally suitable for on-air or other demanding applications.

As of the writing date of this user guide, the Sennheiser HMD 26 headset is very popular for on-air sports broadcasting use. A fine product, it works very well with the Model 230. Note that adding the suffix “-XQ” to the headset's full part number (HMD 26-600-XQ) specifies a 3-pin male XLR connector for the dynamic microphone and a ¼-inch 3-conductor plug for

the stereo headphones. This configuration is very useful, allowing the headset to work directly “out of the box” with the Model 230.

If the writer may digress for a moment to recount a story... an audio dealer once shared a secret with me concerning headsets. He loved selling the “lower-end” (less expensive) models of name-brand headsets, which he did by the veritable “boatload.” Why? Because these usually broke soon after going into service! He knew that on a regular basis he’d receive orders for more of them. Had these users, from the beginning, purchased only premium-quality headsets, their total cost of ownership would have been much less. Enough said...

Headphone Output

The Model 230’s headphone output is compatible with stereo or mono headphones, headsets, or earpieces. Connecting devices with a nominal impedance of 100 ohms or greater is preferred. This shouldn’t be an issue as essentially all contemporary devices already meet this condition.

Devices are connected to the headphone output by way of a ¼-inch 3-conductor phone jack located on the Model 230’s back panel. As is standard for stereo headphones, the left channel is connected to the “tip” lead of the ¼-inch headphone jack. The right channel is connected to the “ring” lead of the jack. Common for both channels is connected to the “sleeve” lead.

Devices with ¼-inch 2-conductor “mono” plugs can also be used with the Model 230’s headphone output. In this arrangement only the tip lead (left channel) will be active. The 2-conductor plug will physically connect (“short”) the ring lead (right

channel) to the sleeve lead (common). Technically this won’t damage the circuitry associated with the right-channel headphone output. (100 ohm protection resistors are electrically in series with the headphone output circuits.) However, energy will be wasted if an audio signal coming out of the right channel goes into a “dead” short. There is a simple means of eliminating this issue; a configuration setting allows the right channel of the headphone output to be disabled. Refer to the Configuration section of this user guide for details.

Main Output

The main output is intended to be the “on-air” signal that connects to the input of an audio console. The output is transformer balanced with a nominal signal level of –2 dBu. The actual level will depend on the gain setting of the microphone pre-amplifier, sensitivity of the microphone, and how loudly a user speaks into the microphone. The transformer used in the main output is intended for professional broadcast applications. It has a low source impedance and can drive lengthy cable runs with no difficulty. It is capable of driving 600 ohm loads but performs best with loads of 2 k ohms or greater. (This should not prove to be an issue as virtually all contemporary audio equipment has a relatively high input impedance.) As the secondary winding of the output transformer connects directly to the main output connector, care should be taken so that DC voltage is never present on the interconnecting cable.

The main output is interfaced by means of a 3-pin male XLR connector located on the Model 230’s back panel. The interconnecting cable’s mating connector (female) should be wired so that signal

high (+ or hot) is on pin 2 and signal low (– or cold) is on pin 3. The cable's shield can be connected to pin 1, but it will have no function. To limit the chance of grounding interaction between the Model 230 and connected equipment, pin 1 on the main output's connector is isolated from any point in the Model 230. The fact that pin 1 "floats" will minimize the chance of hums, noises, or buzzes being present on the equipment connected to the main output.

Line-Level Talkback Output

The line-level talkback output is intended to be connected to control rooms, production trailers, or other locations where talent-originated voice cues are required. The output is transformer balanced with a nominal level of +4 dBu. To enhance talkback audio quality, a compressor circuit controls the dynamic range of the signal coming from the microphone preamplifier.

For protection against accidental connection to cables that have DC power present, the line-level talkback output is capacitor coupled. In series with the talkback output leads are 300 ohm resistors, making the effective output impedance approximately 600 ohms. These resistors create a passive summing network, allowing talkback outputs on multiple Model 230 units to be connected together.

The line-level talkback output is connected by way of a 3-pin male XLR connector which is located on the Model 230's back panel. The mating connector (female) should be prepared so that signal high (+ or hot) is expected on pin 2. Signal low (– or cold) should be expected on pin 3. The cables' shields can be connected to pin 1. But, like the main output, in order to minimize the chance that ground-interaction problems will arise, pin 1 on the

line-level talkback output connector is isolated from the Model 230's chassis and circuitry. By making pin 1 "float," an often-feared "ground loop" problem shouldn't arise.

The line-level talkback output is intended to drive lengthy cable runs that are frequently part of a remote broadcast application. While the output circuitry is not intended to be "on-air" quality, overall audio performance should be very good. Devices connected to the line-level talkback output can range from amplified loudspeakers to analog inputs on matrix intercom systems, and input channels associated with audio consoles. Connecting the talkback output to devices that allow easy control of the signal level can be helpful. For example, connecting to a spare input channel on an audio console provides the flexibility to add gain or attenuate as required. A dedicated talkback-associated output on the audio console can then be connected to the final destination(s).

As previously mentioned, the line-level talkback output on multiple Model 230 units can be directly connected together. Using a simple "Y" or "W" cable, this passive summing (adding together) of talkback signals allows one audio cable to serve as a master talkback path. A side effect from using this passive summing technique is that signal attenuation will occur. The audio quality won't suffer, but an audio "pad" is created. If two line-level talkback outputs are connected together, a signal attenuation of 6 dB can be expected. Connecting three outputs together will result in 9.5 dB of attenuation. And four outputs "malted" together will lead to 12 dB of attenuation. In most cases this attenuation won't pose a problem. Typically

a device that receives the talkback signal, such as an amplified loudspeaker, will have an adjustable input sensitivity.

IFB Input

The Model 230's IFB input is designed to directly connect with "wet" (DC-biased) IFB circuits. These circuits provide DC power and one or two channels of audio over a standard 3-conductor microphone-style cable. Typically, the IFB circuit's interface connector is a 3-pin male XLR wired so that common is on pin 1, DC with channel 1 audio is on pin 2, and channel 2 audio is on pin 3. Some IFB circuits may only have one audio channel. In this case, audio will generally be on pin 3 with pin 2 providing only DC power.

The power supplied by an IFB circuit, normally in the range of 28 to 32 volts DC, is usually sufficient to operate the Model 230's circuitry. The acceptable input range is 24 to 32 volts, with a required current of 125 milliamperes. Note that the specified input voltage is given when measured directly at the Model 230's IFB input connector, not at the source of the IFB circuit. The one or two audio signals provided by the IFB circuit can serve as audio sources for the headphone outputs.

While the Model 230's IFB input was designed for connection to a "wet" IFB circuit, it's also possible to connect line-level audio sources. Please refer to the Technical Notes section of this user guide for details.

Line Inputs

The Model 230 allows two line-level audio sources to be connected. These sources can be individually routed to the left-channel, right-channel, or both the left- and right-channel headphone outputs.

The inputs are balanced, transformer-coupled with a nominal impedance of 10 k ohms. Capacitors, in series with the transformer's input leads, prevent a DC voltage present on a connected source from impacting performance. The line inputs are compatible with signals that have a nominal level of -12 dBV to +6 dBu. Two trim potentiometers, located on the bottom of the Model 230's enclosure, allow signals over this wide nominal level range to be effectively utilized. Audio sources are connected to the line inputs by way of 3-pin female XLR connectors which are located on the unit's back panel.

Prepare the mating connectors (males) so that pin 2 is signal high (+ or hot), pin 3 is low (- or cold), and pin 1 is shield. If connecting a source in this manner results in hum or noise, it's possible that removing the shield connection from pin 1 can eliminate the issue. With an unbalanced source connect pin 2 to signal high (+ or hot) and both pins 1 and 3 to shield. If connecting an unbalanced source in this manner results in hum or noise, connect pin 2 to high (+ or hot) and pin 3 to shield; leave pin 1 unterminated.

Intercom Interface

The Model 230's intercom interface is designed to directly connect with standard single- and dual-channel party-line intercom lines. The one or two audio signals provided by the intercom line can serve as audio sources for the headphone outputs. Each signal can be individually assigned to the left channel, the right channel, or both the left and right channels. The Model 230 can be configured to send talkback audio to either or both of the intercom channels. In addition, the intercom line can also provide the DC power required to operate the Model 230's circuitry.

The intercom line is connected to the Model 230 by way of a 3-pin female XLR connector which is located on the back panel. The mating connector (male) should be wired so that common is on pin 1, DC with channel 1 audio is on pin 2, and channel 2 audio is on pin 3. With single-channel intercom lines common is on pin 1, DC power is on pin 2, and audio is connected to pin 3.

The Model 230's intercom interface is directly compatible with broadcast and production party-line intercom lines associated with systems from manufacturers such as RTS and Clear-Com. Intercom lines associated with other systems should be equally compatible. RTS TW-series systems are normally interfaced using 3-pin XLR connectors. These connectors are wired with common on pin 1, DC power and channel 1 audio on pin 2, and channel 2 audio on pin 3. With many Clear-Com systems, common is on pin 1, DC power is provided on pin 2, and audio is provided on pin 3.

The DC power supplied by the connected intercom line is generally sufficient to operate the Model 230's circuitry. The acceptable input range is 24 to 32 volts, with a required current of 125 milliamperes. Note that the specified input voltage is given when measured directly at the Model 230's intercom connector, not at the source of the intercom line.

External Power Input

An external source of 24 volt DC power can be connected to the Model 230 by way of a 2.1 x 5.5 mm coaxial power jack which is located on the back panel of the unit. The center pin of the jack is the positive (+) connection. While the requirement for the external source is nominally

24 volts, correct operation will take place over a 20 to 30 volt range. The Model 230 requires 90 milliamperes at 24 volts DC for correct operation. Included with each Model 230 is a 24 volt DC external power supply. The power supply's DC output cable has been terminated with a Switchcraft® S760K coaxial power plug. This "locking" type of plug correctly mates with the Model 230's 24 Vdc input jack. The locking feature is important, allowing the external power source to be securely attached to the Model 230.

As previously discussed in this user guide, an IFB circuit or party-line intercom line connected to the Model 230 can serve as the unit's power source. Alternately, an external 24 volt DC source can be connected. For redundancy, the IFB circuit, the intercom line, and the external source can be connected at the same time. If one of them becomes inoperative, one of the remaining sources can provide all Model 230 power.

The Model 230's circuitry establishes the priority in which the unit draws its operating power. If an external source of 24 volt DC power is connected, it will always serve as the primary source. This minimizes the impact that the unit's power draw could have on a connected IFB circuit or intercom line. If no external source of 24 volt DC is connected and both an IFB circuit and an intercom line are connected, power will be drawn only from the intercom line. This is because intercom lines, by design, are better able to supply power to devices such as the Model 230. Multiple devices, such as intercom belt packs, are expected to be connected to, and powered by, a single intercom line. IFB circuits are quite different, typically designed to only supply a limited amount of energy.

So in conclusion, the Model 230's power draw priority was established so as to minimize the chance that IFB circuit performance would be impaired. And, of course, no matter which source is providing power, audio signals from the IFB circuit and intercom line can still serve as headphone output audio sources.

Pushbutton Labeling

The three pushbutton switches used in the Model 230 were selected for several reasons. Foremost was the fact that they are highly reliable, using gold-plated contacts for long life in less-than-ideal environments. A second reason was that applying customized labels to the button caps would be very simple. The labels, text printed on clear material, are placed under the clear caps on the top of the buttons.

From the factory the left button is labeled COUGH, the center button is labeled TALKBACK 1, and the right button is labeled TALKBACK 2. This was selected to be appropriate for many on-air applications in English-speaking locations. But it's expected that these may need to be changed to meet the needs of specific applications.

As a "head start" for some applications, a clear sheet with a number of commonly used button designations printed on it is included in the shipping carton. These were created at the factory using a standard personal computer graphics program and laser printed onto 3M CG3300 transparency film. The desired button labels can be cut out with a pair of scissors or an X-ACTO® knife following the printed guide lines that indicate the required size.

The clear lens on top of each button cap can be removed with a fingernail or small screwdriver. Be certain not to scratch the

button if a screwdriver or other small tool is used. The clear label can be removed and replaced. The button cap is then snapped back into the top of the button housing using finger-pressure only. No tool is required to replace the button cap.

If you need to make your own labels the process is quite simple. Use a personal computer to create the desired text. The finished label size should be 0.625-inches (15.8 mm) square. The completed artwork can then be printed on transparency film sheets using a laser or inkjet printer. These sheets are readily available from most office supply stores. A pair of scissors or an X-ACTO knife will complete the task.

Configuration

For the Model 230 to support the needs of specific applications a number of operating parameters must be configured. These include microphone preamplifier gain, phantom power on/off, headphone source and output mode selection, and operating modes. One 12-position and three 8-position DIP switch assemblies are used to establish the desired configuration. These switch assemblies are referred to as SW1 through SW4, with individual switches designated as SW1-1, SW1-2, etc. The switch assemblies are accessed through openings in the bottom of the Model 230's enclosure. The enclosure does not have to be disassembled to gain access to the switches.

To prevent unauthorized personnel from changing the configuration settings, a security plate is attached to the bottom of the Model 230's enclosure. For convenience, text and graphics on the security plate provides a summary of the configurable parameters and related information.

Refer to Appendix A for a representative view. The security plate is held in place by means of four rubber bumpers (“feet”) that have built-in screws. Using your fingers, remove the four bumpers so that the plate can be removed. Refer to Figure 3 for a detailed view of the configuration switch assemblies.

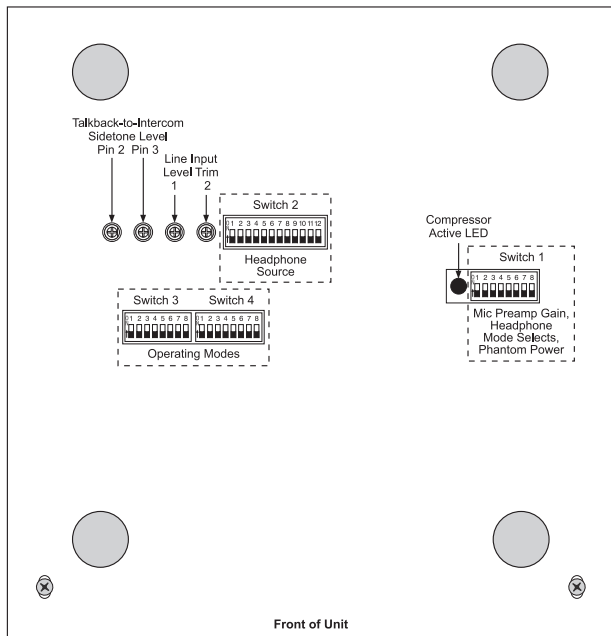

Intercom Pin 2 is RTS™ TW Channel 1.
Intercom Pin 3 is RTS™ TW Channel 2,
or Clear-Corr® Channel 1.

Figure 3. Bottom view of Model 230 showing configuration switches, trim pots, and compressor active LED

Microphone Preamplifier Gain and Phantom Power

Five switches are used to set the gain of the microphone preamplifier. One switch is used to select the on/off status of the phantom power supply.

Microphone Preamplifier Gain

Switches SW1-1 through SW1-5 are used to select the gain of the microphone preamplifier. The choices are 20, 30, 40, 50, 60 dB; 0 dB (no gain) is also available. Only one switch should be enabled at a

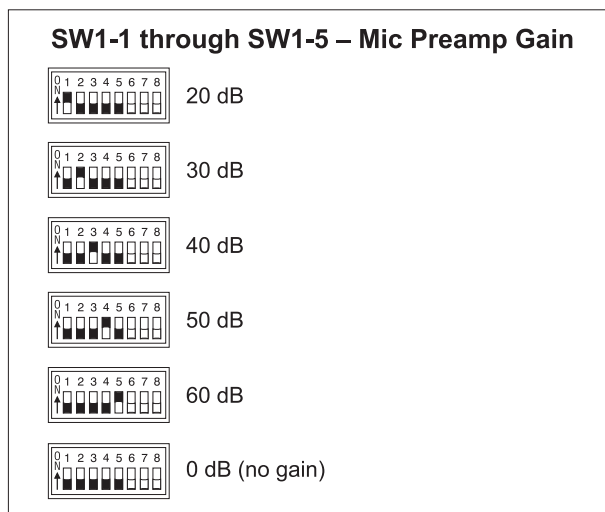

Figure 4. Microphone preamplifier gain switch settings

time. There’s no problem changing the gain setting while the unit is operating. Audio clicks or pops might occur during gain transitions, but this shouldn’t be a major issue as long as associated monitor loudspeakers are temporarily attenuated or muted.

Selecting the correct amount of gain for an application might take a little experimentation. The goal is to bring the mic’s signal up to line level, nominally –2 dBu for the Model 230’s main output. Operating at this signal level will help to ensure the delivery of “clean” audio to the connected device. It’s also acceptable to connect a live-level audio source to the microphone input. In this case selecting 0 dB (no gain) would be appropriate.

The output of the Model 230’s microphone preamplifier is used by the main output and, by way of the compressor circuit, the talkback outputs. So creating a nice “hot” signal will help maintain audio quality, specifically a high signal-to-noise ratio, when driving the often-lengthy cable runs.

Unfortunately, there's no "perfect" gain setting that this guide can recommend. The two issues that impact the setting are output sensitivity of the connected microphone and the acoustical output level of the microphone's user. With some headset microphones, such as the Sennheiser HMD 26, selecting an initial setting of 40 dB is appropriate. Users who speak loudly might need to have the gain reduced to 30 dB. Quiet users might need 50 dB of gain.

An LED indicator is provided as an aid in correctly setting the gain of the microphone preamplifier. Red in color, this LED is located adjacent to switch assembly 1. It is visible by observing the bottom of the Model 230's enclosure when the security plate has been removed. Technically, this red LED lights whenever the compressor circuitry is controlling the dynamic range of the signal coming from the microphone preamplifier. The threshold is set to be 2 dB above the Model 230's nominal internal operating level. So a good "rule of thumb" is to adjust the gain of the microphone preamplifier such that the compressor active LED lights ("flashes") when the connected microphone is sending signal peaks. During normal operation the LED should not remain fully lit when audio is present on the mic input.

It's important to remember that the compressor active LED is used to assist in setting the gain to the optimal value. It doesn't necessarily indicate that the main output's signal is being compressed. Unless specifically configured to perform otherwise, the output of the compressor is only used for the talkback output.

It's expected that the 20 and 60 dB gain settings will not often be used. But there are always exceptions and that's why they were

included. It's possible that with a very "hot" microphone, such as a phantom-powered condenser-type, 20 dB of gain could be correct. It's also possible that a microphone with a very low-level output, such as a ribbon-type, would need 60 dB of gain. But in general, the 30, 40, and 50 dB gain settings will serve most applications.

Note that if no gain switch is set to its active (on) position the preamplifier will operate at unity (0 dB) gain. This is provided for compatibility when line-level signals need to be connected to the microphone input. But with a microphone connected as the input source one should never use the 0 dB setting. The issue is that with no gain added to the microphone input signal, the relative noise floor on the main and talkback outputs will be much too high.

Phantom Power On/Off

The Model 230 can provide 48 volt nominal phantom power to the connected microphone. Switch SW1-8 controls whether or not phantom power is active. By phantom power's very nature it could be left applied to the microphone input at all times. But generally people prefer to turn it off unless required for a specific microphone.

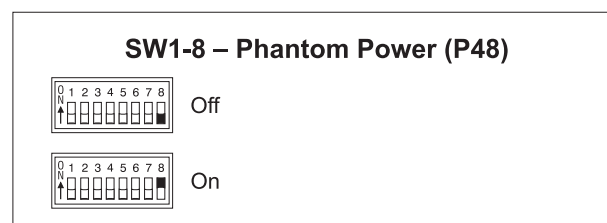

Figure 5. Phantom power switch settings

Headphone Source Selection

Switch assembly SW2 is used to configure the source or sources that are routed to the stereo headphone output. The six headphone sources are IFB channel 1, IFB channel 2, line input 1, line input 2, intercom channel 1, and intercom channel 2. The IFB channels are provided by way of the IFB input connector located on the Model 230's back panel.

The line inputs are connected using two connectors also located on the back panel. Associated with line inputs 1 and 2 are level trim potentiometers. They are provided so that audio sources with a wide range of nominal levels can be effectively used as cue sources. Please refer to the Advanced Operation section of this user guide for details on using the trim pots.

Audio associated with intercom channels 1 and 2 is provided by way of the intercom interface whose connector is also located on the back panel. Two trim pots are associated with the intercom channels. They allow adjustment of the user's sidetone level—the talkback audio signal that is returned to a headphone output when a talkback-to-intercom function is active.

Each of the available input sources can be assigned to the headphone output's left channel, right channel, or both the left and right channels. The Model 230's circuitry allows any combination of source assignments to be made. For example, consider the situation where a single-channel intercom line, with audio present only on pin 3, is connected. In this case it may be desirable to assign this intercom audio source to both the left and right channels. This would entail setting switches SW2-6 and SW2-12 to their on positions. All other switches would remain in their off positions.

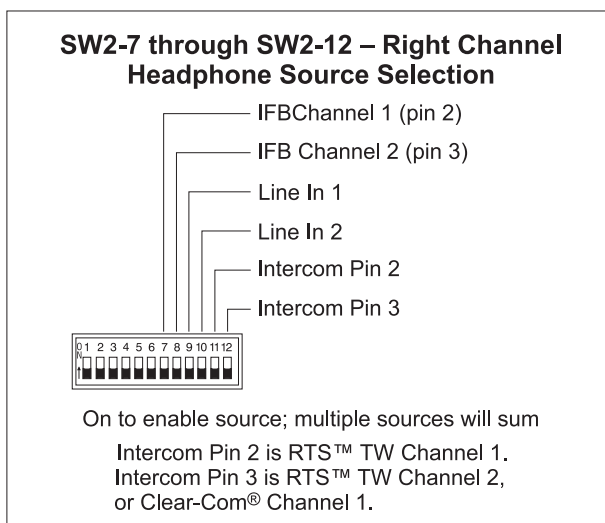
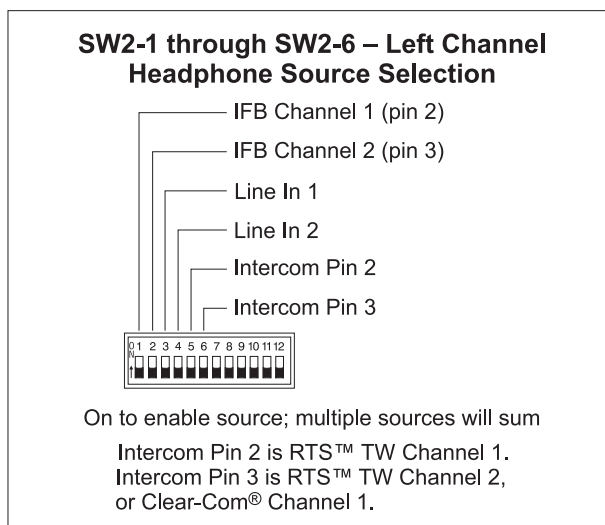

Figure 6. Left and right channel headphone source selection settings

A more complex application might have a 2-channel IFB circuit connected to the IFB input and a line-level audio signal from a golf event “spotter” connected to line input 1. In a case such as this, it would be typical for IFB channel 1 to be assigned to the headphone's left channel, IFB channel 2 assigned to the right channel, and line input 1 also assigned to the right channel. This would allow both IFB channel 2 and “spotter” audio to be heard in the headphone's right-channel output. To achieve

this would require that switches SW2-1, SW2-8, and SW2-9 be placed in their on positions.

Note that in some cases a user may wish to wear a headset or a pair of headphones in a left/right orientation opposite of what is usual. In this situation the transducer designated for the left ear would actually supply audio to the user's right ear, and vice versa. A specific application where this occurs is when on-air talent needs to have a headset's boom microphone come across the right side of their face, rather than the more-typical left side. In this case it's important to select the left- and right-channel headphone source assignment accordingly. With the Model 230's flexible source selection there's no reason why users, such as on-air talent, shouldn't have their cue sources assigned correctly.

Special applications may benefit from using the Model 230 in a special "2-channel headphone output mixer" mode. This is accomplished by first configuring the headphone output to monaural. (Details on how to accomplish this are described later in this section of the user guide.) Next the cue source whose level is to be adjusted by the rotary control on the left side of the front panel is assigned to the left channel. Finally, the cue source whose level is to be adjusted by the right control is assigned to the right channel. During operation the user will create their desired cue mix using the two front-panel controls.

There may also be cases where a monaural "single-muff" headset or headphone will be connected to the Model 230's headphone output. In this case the desired source must be routed only to the left channel. This is because the 2-conductor plug that's typically associated with a mono headset

or headphone will connect only to the tip lead (left channel) of the headphone output. Signals assigned to the right channel will not be heard by the user.

Headphone Output Mode

Switch SW1-6 allows a monaural headphone output to be created. This is accomplished by summing (adding) the selected left- and right-channel cue signals. The combined signals are sent to both the left- and right-channel headphone output driver circuits. The outputs of these circuits connect, by way of 100 ohm series protection resistors, to the headphone output jack.

The headphone output monaural mode feature was specifically included so that a special "2-channel headphone mix" mode can be created. By enabling the mono mode, the two front-panel user level controls ("pots") can be used to create the desired "mix" of signals being sent to the headphone outputs. Many, many applications, especially in production settings, can benefit from this capability. The desired cue sources must be carefully assigned to take advantage of the monaural mode. The first cue source should be assigned, using the DIP switches, to the left channel. Its output level will be adjusted by the left control. The second cue source should be assigned to the right channel. Its output level will be adjusted by the right control.

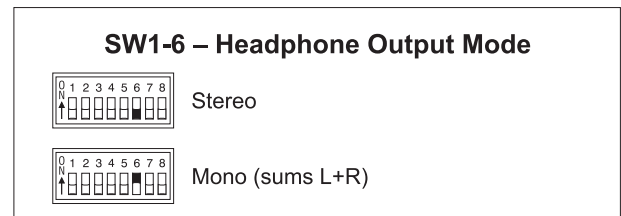

Figure 7. Headphone output mode settings

There is one limitation related to the headphone output mode. It's the fact that the output will be 2-channel monaural. Whatever signal is present on the headphone output's left channel will also be present on the right channel. (The exception is if the right channel output is disabled using the DIP switch setting.) A stereo headphone mix can't be created. But in most cases this limitation won't overshadow the benefit of being able to create the mix. For signal-flow clarification please review the block diagram located at the end of this user guide.

Headphone Output—Right Channel Status

Switch SW1-7 allows the right channel of the headphone output to be disabled. This is provided for applications where monaural headsets or headphones are going to be connected. In general, monaural devices use 2-channel (tip and sleeve) ¼-inch plugs. When inserted into the Model 230's stereo (3-conductor) headphone output jack the right channel, electrically connected to the jack's ring lead, will be shorted. While this condition should not damage the output circuit, it will cause current to flow unnecessarily. To minimize this possibility disable the right channel output by placing switch SW1-7 to its on position.

It's important to note that the circuitry that disables the right channel is electrically just prior to the right channel output circuit. It is after ("post") all other circuitry, including the source assignment DIP switch, level controls, and monaural function. It will not impact normal use of the other functions, including the ability to create the special "2-channel headphone mix" mode previously discussed. For signal-flow clarification please review the block diagram located at the end of this user guide.

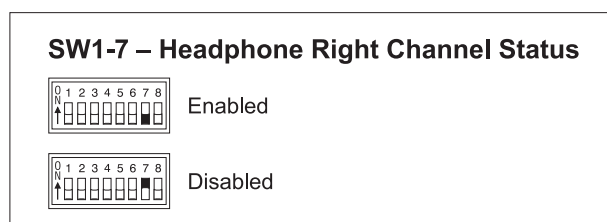

Figure 8. Headphone output—right channel status settings

Operating Modes

The sixteen switches associated with switch assemblies SW3 and SW4 are used to configure the Model 230's operating modes. Technically, these switches "talk" to the microcontroller integrated circuit and associated software that give the Model 230 its "smarts." The software has been carefully designed to provide a number of different ways in which the unit can function. It's critical to carefully review the available options and choose the ones that best meet the needs of a specific application. Note that switches can be changed even while the Model 230 is powered up and operating. The unit's operating characteristics will change in "real-time" in response to configuration changes.

Main Output Button Mode

Switches SW3-1 and SW3-2 configure how the main output button functions.

There are four available modes:

- Push to mute: In this mode the main output is normally active. The main output will mute whenever the button is pressed and held. This is the "cough" mode typically used for on-air sports broadcasting applications.
- Push to talk: In this mode the main output is normally muted. The main output will become active whenever the button is pressed and held.

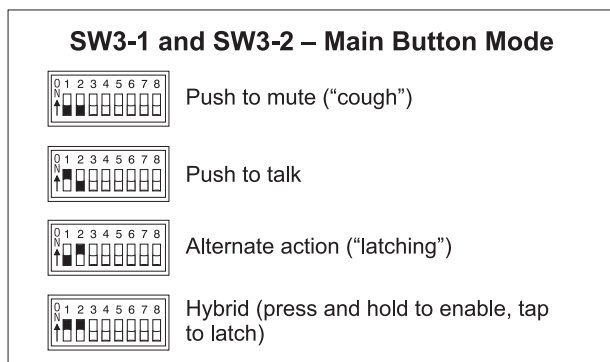

Figure 9. Main output button mode settings

- **Alternate action:** In this mode the main output will change between its active and muted state whenever the button is pressed. Upon power up the main output will be in its muted state.
- **Hybrid:** This mode is a combination of push to talk and alternate action. It's similar to the way talk buttons function on user stations associated with broadcast and production intercom systems. If the button is pressed and held, the main output will become active until the button is released. If the button is momentarily "tapped" the main output will change state. Upon power up the main output will be in its muted state.

Talkback 1 Button Mode

Switch SW3-3 configures how the talkback 1 button functions.

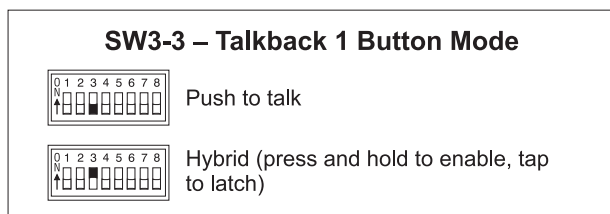

Figure 10. Talkback output 1 button mode settings

Two modes are available:

- **Push to talk:** In this mode the talkback 1 button is normally off. The function becomes active whenever the button is pressed and held.
- **Hybrid:** This mode is a combination of push to talk and alternate action. If the button is pressed and held, the talkback 1 button will become active until the button is released. If the button is momentarily "tapped" the state will change. Upon power up the talkback 1 button will be in its off state.

Talkback 2 Button Mode

Switch SW3-4 configures the way the talkback 2 button functions.

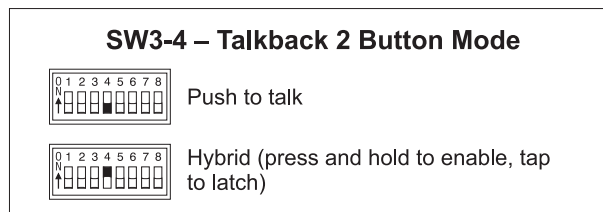

Figure 11. Talkback output 2 button mode settings

Two modes are available:

- **Push to talk:** In this mode the talkback 2 button function is normally off. The function will become active whenever the button is pressed and held.
- **Hybrid:** This mode is a combination of push to talk and alternate action. If the button is pressed and held, the talkback 2 button will become active until the button is released. If the button is momentarily "tapped" the state will change. Upon power up the talkback 2 button will be in its off state.

Talkback 1 Function Mode

Switches SW3-5 and SW3-6 configure the overall operation of the talkback 1 button.

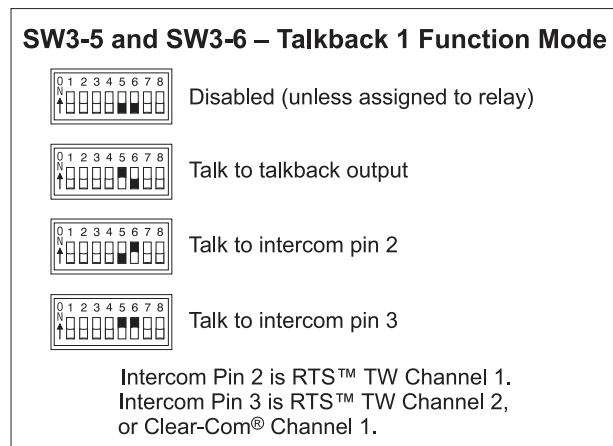

Figure 12. Talkback output 1 function mode settings

Four modes are available:

- **Disabled:** In this mode the talkback 1 button is disabled. The exception is if the auxiliary relay is configured to follow the status of the talkback 1 button. In this case the button will control the relay; no other functions will be impacted.
- **Talk to talkback output:** In this mode the talkback 1 button will control the routing of audio to the line-level talkback output.
- **Talk to intercom interface pin 2:** In this mode the talkback 1 button will control the routing of talkback audio to pin 2 of the intercom interface. Pin 2 is channel 1 of an RTS TW intercom system.
- **Talk to intercom interface pin 3:** In this mode the talkback 1 button will enable the routing of talkback audio to pin 3 of the intercom interface. Pin 3 is channel 2 of an RTS TW intercom system. For a single-channel Clear-Com intercom system it will be channel 1.

Talkback 2 Function Mode

Switches SW3-7 and SW3-8 configure the overall operation of the talkback 2 button.

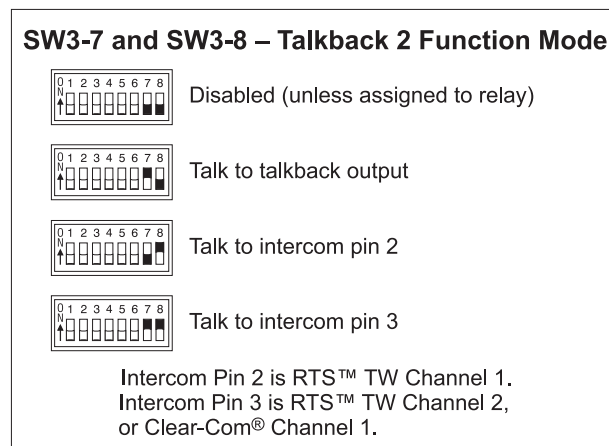

Figure 13. Talkback output 2 function mode settings

Four modes are available:

- **Disabled:** In this mode the talkback 2 button is disabled. The exception is if the auxiliary relay is configured to follow the status of talkback button 2. In this case the button will control the relay; no other functions will be impacted.
- **Talk to talkback output:** In this mode the talkback 2 button will control the routing of audio to the line-level talkback output.
- **Talk to intercom interface pin 2:** In this mode the talkback 2 button will control the routing of talkback audio to pin 2 of the intercom interface. Pin 2 is channel 1 of an RTS TW intercom system.
- **Talk to intercom interface pin 3:** In this mode the talkback 2 button will enable the routing of talkback audio to pin 3 of the intercom interface. Pin 3 is channel 2 of an RTS TW intercom system. For a single-channel Clear-Com intercom system it will be channel 1.

Headphone Output Operating Modes

The user is provided with two rotary level controls (“pots”) that are associated with the headphone output. Switches SW4-1, SW4-2, and SW4-3 are used to configure the way the controls function. With just these three switches a wide range of operating modes can be configured. Carefully reviewing the capabilities of the available functions may prove worthwhile.

Dual-Channel or Stereo Mode

Switch SW4-1 is used to select whether the controls provide a dual-channel (“level/level”) or stereo (“level/balance”) mode of operation. In the level/level mode the two controls operate independently, each controlling the level of one of the headphone output channels. This mode is generally used for on-air broadcast applications where independent cue signals are provided to the left- and right-headphone channels. In the level/balance mode the left control sets the overall output level for both headphone channels. The right control is used to adjust the balance (the relative levels) of the left and right channels. This mode is generally best suited for applications where a stereo cue source is being provided.

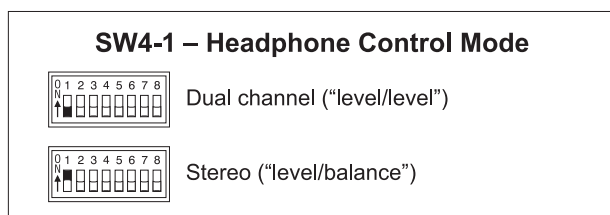

Figure 14. Headphone control mode settings

Reverse Left/Right Mode

Switch SW4-2 is used to select whether the rotary controls are in the normal or reverse left/right mode of operation. When set to the normal mode, and level/level

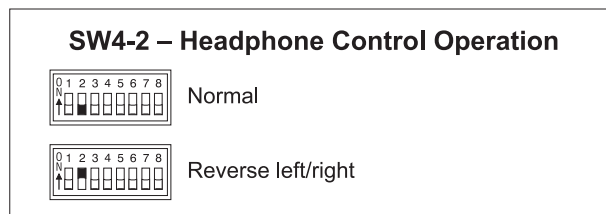

Figure 15. Headphone control operation settings

mode is also selected, the left control adjusts the level of headphone output’s left channel. (This is the signal that appears on the tip lead of the ¼-inch 3-conductor jack.) The right control adjusts the level of the right channel. When set to the normal mode, and the level/balance mode is also selected, turning the balance control in the counterclockwise direction increases the perceived level of the left channel, and vice versa.

As you may have already guessed, when selecting the reverse left/right mode of operation everything is reversed! To be more specific, when selected for reverse mode, and the level/level mode is also selected, the left control adjusts the headphone output’s right channel (output jack’s ring lead) while the right control adjusts the left channel. When selected to the reverse mode, and the level/balance mode is also selected, turning the balance control in the counterclockwise direction increases the perceived level of the right channel, and vice versa.

The reverse mode is provided specifically for cases where a headset’s left and right ear pieces are placed on a user’s head in a reverse orientation. This ensures that the user is provided with a consistent and easy-to-use set of headphone level controls.

Minimum Level Mode

Switch SW4-3 is used to configure the headphone output's minimum level. In the -40 dB mode the minimum headphone output level is 40 dB below maximum. The headphone output channels will never fully mute. This ensures that any audio signal present on the selected Model 230 inputs will always be present on the headphone output. In most on-air broadcast applications this is the appropriate setting.

When the full mute mode is selected and the level/level mode is also selected, moving either control to its fully counterclockwise position will cause its associated channel to fully mute.

When the full mute mode is selected and the level/balance mode is also selected, turning the level control to its fully counterclockwise position will cause both headphone channels to mute. Turning the balance control to either its fully clockwise or fully counterclockwise position will cause the appropriate channel to mute.

Selecting the full mute mode may be appropriate for applications where minimizing the chance of audio "leakage" is important. This could occur when the connected headset or headphones are at times placed on a desk or tabletop.

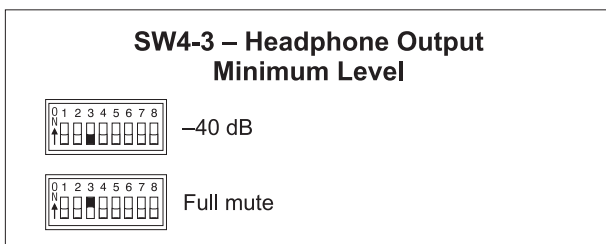

Figure 16. Headphone output minimum level settings

Main Button Mode

Switch SW4-4 is used to configure how the main button responds to talkback activity. Specifically it applies only when the system is selected for the on-air mode and the main output button mode has been configured for alternate action or hybrid. When the main button mode is set to normal and a talkback function is active, the main output will, if "latched" on, be temporarily placed in its off (muted) state. When the talkback function is no longer active the main output will return to its previous latched on state.

When the talkback forces main button to latch off mode is selected, and a talkback function becomes active, the main output will, if latched on, be placed in its off (muted) state and the latch condition forced off. When the talkback function is no longer active the main output will remain in the latched off state.

The differences in how the main button modes impact operation and user comfort are relatively subtle. The nuances of both modes should be considered before a final selection is made. If possible, experimenting with both modes in a test environment might prove to be very helpful.

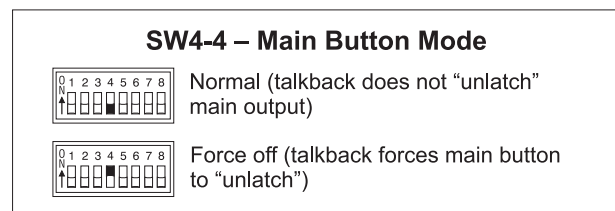

Figure 17. Main button mode settings

Auxiliary Relay Control Mode

Switch SW4-5 and SW4-6 configure the operating mode of the auxiliary relay.

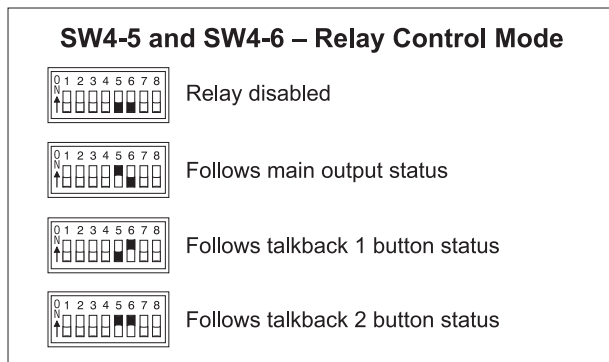

Figure 18. Auxiliary relay control mode settings

Four modes are available:

- **Relay disabled:** In this mode the relay is disabled and will never change state.
- **Follows main output status:** In this mode the relay will follow the state of the main output. Specifically, the relay will change state (energize) whenever the main output is active.
- **Follows talkback 1 button status:** In this mode the relay will follow the state of the talkback 1 button. Specifically, the relay will change state (energize) whenever the button is active.
- **Follows talkback 2 button status:** In this mode the relay will follow the state of the talkback 2 button. Specifically, the relay will change (energize) state whenever the button is active.

Sidetone Mode

Switch SW4-7 is used to enable or disable the sidetone mode. This is provided to support applications where the supplied cue audio signals don't include audio from a Model 230's user microphone. Audio from their own microphone is never returned, via an external cue feed, to one

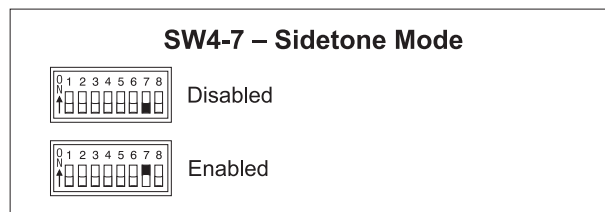

Figure 19. Sidetone mode settings

of the Model 230's inputs. By enabling the sidetone function the audio routing and operation of the Model 230's headphone level controls work quite differently. Whenever microphone audio is sent to the main output or talkback functions, it is also routed to the left and right channels of the headphone output. This provides the on-air talent or production users with a confidence ("sidetone") audio signal.

When the sidetone mode has been enabled the two rotary controls no longer provide a level/level or a level/balance mode of operation. Instead, the left control is used to adjust the level of the sidetone signal being sent to the left and right channels of the headphone output. The right control no longer adjusts the level of the right channel headphone output or, if configured for "level/balance" mode, the left/right balance. The right control is used to adjust the level of the external cue signals that are assigned to the left and right channels of the headphone output. To highlight, the right rotary control acts as a stereo level control—the left/right balance of the externally provided cue signals can't be adjusted. This is a compromise that shouldn't pose a serious operational problem.

Note that when the sidetone mode has been enabled two of the three configurable headphone control parameters continue to function in their normal ways. The minimum level mode performs the same functions. The reverse left/right function

selects which control is used for sidetone level and which control is used to adjust the level of the externally provided cue sources. However, the headphone control mode that selects between dual channel (“level/level”) and stereo (“level/balance”) is no longer active.

System Mode

Switch SW4-8 is used to configure the overall operating mode of the Model 230. Understanding how the two modes impact overall system operation will ensure that correct operation and maximum usability will occur. When selected to the on-air mode, the main output will mute whenever a talkback function is active. The on-air mode should be selected for all on-air broadcast applications. It’s imperative that the main output be muted whenever on-air talent is using one of the talkback functions to communicate with production personnel.

When the system mode is set for production, the main output is never muted in response to a talkback function being active. It is controlled only by the main output pushbutton. This mode allows the main output to be used, for example, as an additional talkback output. In this way, the main output and talkback output functions can be used independently with neither impacting the other. This also allows all three buttons to be used simultaneously. Note that as is always the case the audio source for the main output is the output of the microphone preamplifier.

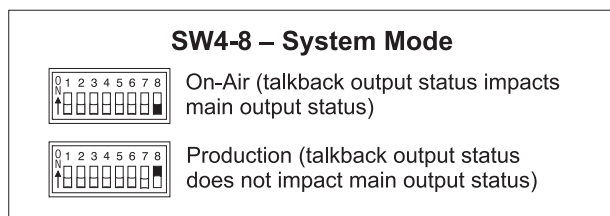

Figure 20. System mode settings

In summary, when selected for the correct application, each of the system modes can prove to be very useful. A thorough study of how they impact the Model 230’s operation can lead to many interesting and powerful uses.

Conclusion

Once the switches have been set to the desired configuration, it may be time to reattach the security plate. The exception is if the trim pots associated with the line inputs and talkback-to-intercom sidetone need to be adjusted. Details are provided later in this user guide. The plate attaches using the four rubber bumpers. They should be hand-tightened only; no tools are to be used.

Operation

At this point the desired input, output, and power connections should have been made. The button labels may have been revised. After carefully reviewing the application, the configuration switches should have been set. Normal operation of the Model 230 can now begin. The unit will begin functioning as soon as a power source is connected. As previously discussed, power for the Model 230 can be provided by an IFB circuit, an intercom line, or an external source of 24 volt DC. It’s important to highlight the fact that the Model 230 is an active device. Audio signals will not be present on the outputs unless correct power has been supplied. Specifically, the microphone does not passively “cut through” to the main output XLR connector!

Upon Model 230 power up, the four status LEDs will light in succession as a firmware “boot up” indication. The unit will then

begin normal operation. Depending on the selected configuration, one LED associated with the state of the main output may be lit. The user is now presented with three buttons, four LEDs, and two rotary controls. These are simple to operate and understand, as will be described in the following paragraphs.

Pushbutton Switches and Status LEDs

Three pushbutton switches are used to control the main output and the talkback functions. The way each operates depends on the selected configuration. Four LED indicators are located adjacent to the buttons. They reflect the status of the main output and the talkback functions.

Main Output Button and LED Indicators

The button on the left, factory labeled as COUGH, functions according to the selected configuration. Two LED indicators, located directly above the button, are associated with the status of the button and/or the main output. If the Model 230 is set to the on-air mode the green LED, located on the right, is lit whenever the main output is active. This could be considered as an “on-air” or mic active indicator. At the least it should serve as a “careful what you say” warning! The red LED, located on the left, will be lit whenever the main output is muted. This indicates that it’s safe to speak as one sees fit.

If the Model 230’s system mode is configured to production the red LED will never light. This is to reflect the fact that the main output button has now taken on a function similar to that of one of the talkback buttons. To clarify, when the system mode is set to production the red LED will never light. In the production mode the green LED will light whenever the main output is active.

Main Output Button Modes

- **Push to mute:** If this mode is selected the main output is normally active. The main output will mute whenever the button is pressed and held.
- **Push to talk:** If this mode is selected the main output is normally muted. The main output will become active whenever the button is pressed and held.
- **Alternate action:** If this mode is selected the main output will alternate between its active and muted states whenever the button is pressed. Upon power up the main output will be in its muted state.
- **Hybrid:** This mode is a combination of push to talk and alternate action. It is similar to the way that talk buttons function on user stations associated with broadcast or production intercom systems. If the button is pressed and held the main output will become active until the button is released. If the button is momentarily “tapped” the main output will change state. Upon Model 230 power up the main output will be in its muted state.

Main Output vis-à-vis Talkback Activity

This short section applies only in the case where the Model 230’s system mode is configured for on-air and the main output button mode is set to alternate action or hybrid.

How the main output responds to talkback activity depends on the configuration of the main output mode. In the normal mode talkback activity will always cause the main output to be placed in its off state. If the main output was in the “latched” on state when talkback began, once talkback activity ends that state will resume; the main output will again be in

its on (“latched”) state. If the main output mode is configured to force off, talkback activity will cause the main output to be placed in its off state. Once talkback activity ends the main output will remain in its off (“unlatched”) state. In critical on-air broadcast applications it’s important that a Model 230 user be aware of how the selected mode impacts operation.

Talkback 1 Button and LED Indicator

The button in the center, factory labeled TALKBACK 1, controls the function associated with the talkback 1 button. The manner in which the button functions depends on the way it was configured. An LED indicator, green in color, is located directly above the button. It lights whenever talkback 1 is active. If the talkback 1 function mode has been configured for disabled, it will light only if the auxiliary relay has been assigned to follow the talkback 1 button. If the Model 230 is selected to the on-air system mode, whenever talkback 1 is active the main output will be placed in the muted state. If the Model 230 is set to the production mode the status of talkback 1 will not impact the main output.

Talkback 1 Button Modes

- **Push to talk:** If this mode is selected the function associated with the talkback 1 button is normally off. The function will become active whenever the button is pressed and held.
- **Hybrid:** This mode is a combination of push to talk and alternate action. If the button is pressed and held, the function associated with the talkback 1 button will become active until the button is released. If the button is momentarily “tapped” the function will change state. Upon Model 230 power up talkback 1 will be in its off state.

Talkback 2 Button and LED Indicator

The button on the right, factory labeled TALKBACK 2, controls the function associated with the talkback 2 button. The manner in which the button functions depends on how it was configured. An LED indicator, green in color, is located directly above the button. It lights whenever talkback 2 is active. If the talkback 2 function mode has been configured for disabled, it will light only if the auxiliary relay has been assigned to follow the talkback 2 button. If the Model 230 is selected to the on-air system mode, whenever talkback 2 is active the main output will be placed in the muted state. If the Model 230 is set to the production system mode the status of talkback 2 will not impact the main output.

Talkback 2 Button Modes

- **Push to talk:** If this mode is selected the function associated with the talkback 2 button is normally off. The function will become active whenever the button is pressed and held.
- **Hybrid:** This mode is a combination of push to talk and alternate action. If the button is pressed and held, the function associated with the talkback 2 button will become active until the button is released. If the button is momentarily “tapped” the function will change state. Upon Model 230 power up talkback 2 will be in its off state.

Headphone Output Level Controls

Two rotary controls (“pots”) are located on the Model 230’s front panel and are associated with the headphone output. The way the controls function depends on the selected configuration. One configuration parameter sets the controls to operate in a level/level or a level/balance mode.

Another parameter allows the left/right assignment of the controls to be reversed. A third parameter selects whether the headphone output channels will maintain a minimum output level or can be fully muted. In most cases the headphone output will be configured for stereo, rather than monaural, operation. The following paragraphs will describe how the controls will function in that scenario.

Level/Level Mode

When set to the level/level mode, the two controls operate independently. Each control sets the output level of one channel of the stereo headphone output. If configured to the normal mode, the control on the left side is used to adjust the level of the headphone output's left channel. The control on the right is used to adjust the level of the right channel. If configured to the reverse left/right mode, the control on the left side adjusts the headphone output's right channel. The control on the right adjusts the left channel. When in the level/level mode, and the minimum output level is set for -40 dB, turning each control to its fully counterclockwise position will place its respective output level 40 dB below its maximum. This setting ensures that talent will never be fully "isolated" from potentially important cue signals. If present on one of the Model 230's inputs and assigned to the headphone channels, some audio signal will always be present on the headphone output. If set to the full mute mode, turning each control to its fully counterclockwise position will cause its respective output to fully mute.

Each level control has a mechanical step (detent) that is located at the halfway (50%) position of its rotation range. This is intended to serve as an aid to Model 230 users. In an ideal installation, setting the

controls to their detent position will result in a comfortable headphone output level. The user, in response to a changing operating environment, can then move the level controls to get more or less level as desired. The detent position will always remain as a useful reference point. To achieve this condition the audio level on the connected IFB circuit, or line inputs, will have to be calibrated as required. This is somewhat counter to the usual mentality of just providing the user with whatever level comes up by default. Spending a few extra minutes "trimming" the audio levels can result in much happier, and more productive, talent. As previously mentioned, a level trim potentiometer is associated with each line input. If the line inputs are utilized as cue sources, adjusting the trim pots may be helpful in achieving the desired adjustment range of the level controls. Refer to the Technical Notes section of this user guide for details.

Level/Balance Mode

When set to the level/balance mode, the two controls operate together to adjust the desired headphone output level. The control on the left adjusts the overall level of both the left and right channels. The balance control, located on the right, adjusts the relative left/right level balance. In this mode the controls operate in a manner reminiscent of a consumer audio amplifier or receiver. If set to the normal mode, rotating the balance control in the counterclockwise direction reduces the level of the right channel providing the user with more perceived level in the left channel. If set to the reverse mode, rotating the balance control in the counterclockwise direction reduces the level of the left channel providing the user with more perceived level in the right channel.

When in the level/balance mode and the minimum output level is set to -40 dB, turning the level control to its fully counterclockwise position will place both headphone output channels to 40 dB below maximum. This ensures that talent will never be fully “isolated” from potentially important cue signals. In addition, rotating the balance control to either its fully clockwise or fully counterclockwise position will cause the applicable channel to be 40 dB below its maximum. If set to the full mute mode, turning the level control to its fully counterclockwise position will cause both the left and right channels to fully mute. In addition, rotating the balance control to either its fully clockwise or fully counterclockwise position will cause the applicable channel to fully mute.

Each control has a mechanical step (detent) that is located at the halfway (50%) position of its rotation range. The balance control will typically be set to its center, detent position, making the level of the left and right channels equal. In an ideal installation, the level control can also be set to its detent position and provide a comfortable headphone output level. This will allow the user, in response to their preference or a changing environment, to adjust the level and balance controls as desired. The detent positions will always remain as a useful reference point. To achieve this condition the audio level on the connected IFB circuit, or line inputs, must be adjusted as required. Spending a few extra minutes “trimming” the connected audio levels, rather than just providing whatever happens to come up, should prove worthwhile. The result will be talent that is more relaxed, and an overall production that works more smoothly. As previously mentioned, a level trim potentiometer is associated with each line input. If the line

inputs are utilized as cue sources, adjusting the trim pots may be helpful in achieving the desired adjustment range of the level controls. Refer to the Technical Notes section of this user guide for details.

Monaural Headphone Output Level Control Operation

As previously discussed, the headphone output can be set for monaural operation. This option is specifically provided so that a “2-channel headphone mix” mode can be created. If this has been enabled, the two front-panel level controls are used as a cue source mixer. Independent cue inputs will be assigned to each channel, serving as the mix sources. How the controls respond when placed in their fully counterclockwise position will depend on the configuration. By default the output level will be 40 dB below its maximum level. An alternate configuration will make the outputs mute.

Sidetone Mode

Whenever the sidetone mode is enabled, the functions carried out by the rotary controls are quite unique. The left control adjusts the level of the “sidetone” confidence audio signal that is sent to the left and right channels of the headphone output. This audio signal is post-compressor, and is active whenever the main output, talkback 1, or talkback 2 functions are active. The right control adjusts the level of the cue signals being routed to the left and right channels of the headphone output. Using the two controls, the operator can easily create the desired mix of themselves (“sidetone”) and the “mix minus” cue signal(s).

To get maximum performance from the sidetone mode, one simple calibration process may need to be performed. If one

or both of the talkback-to-intercom functions are configured for use the sidetone trim pots associated with them should be set for minimum sidetone level. This is accomplished by adjusting the trim pots to their fully counterclockwise positions. This will minimize the level “build up” that would occur when both the internal and the intercom-related sidetone audio is being sent to the headphone output. The goal is for the sidetone level to remain as constant as possible, no matter what function (main output, talkback-to-line-level-output, or talkback-to-intercom) is active.

Advanced Operation

Adjusting the Line Input Trim Pots

As has been previously mentioned, associated with the line inputs are trim pots that allow the input levels to be adjusted. The two trim pots are accessible by way of round openings in the bottom of the Model 230’s enclosure. By adjusting these trim pots, signals with a nominal level of -12 dBV to $+6$ dBu can be effectively used as cue sources. Unfortunately, there are no definitive rules regarding how best to adjust the trim pots, but some suggestions may prove to be valuable. Depending on how the line inputs are utilized, the trim pots can be used to either adjust the absolute level of each line input signal, or to adjust the relative level of the signals when compared to other sources. The following examples may provide some clarification.

Let’s begin with an application that has a stereo cue source connected to the line

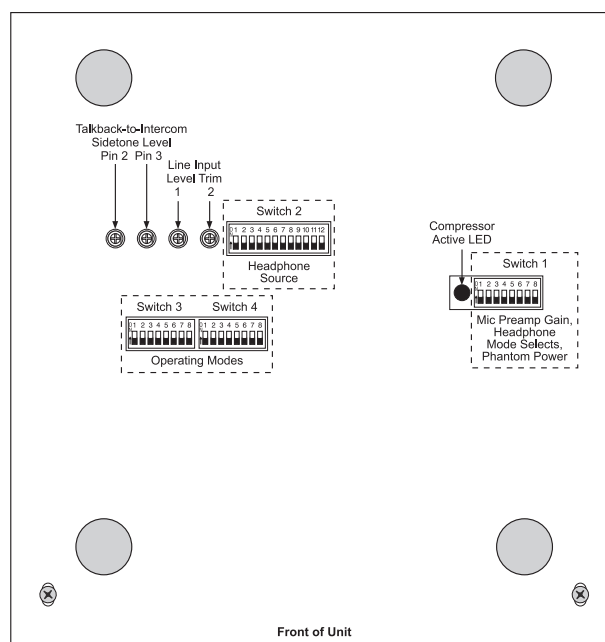

Intercom Pin 2 is RTS™ TW Channel 1.
Intercom Pin 3 is RTS™ TW Channel 2,
or Clear-Com® Channel 1.

Figure 21. Bottom view showing line input and talkback-to-intercom sidetone trim pots

inputs. The source selection DIP switches are configured to create a stereo headphone output with line input 1 assigned to the left channel and line input 2 assigned to the right channel. Begin the trim pot adjustment process by moving the user level controls (located on the front panel) to their detent (50% of rotation) positions. Then, with the stereo cue source providing signal at its normal level, adjust the trim pots to provide a comfortable level to the connected headphones. The user can now, in response to changing conditions, adjust the front-panel level controls as desired. Returning the controls to their detent positions will always provide the “reference” level to the headphone output.

A second example has the IFB input and line input 1 both providing cue sources. Channel 1 of the IFB circuit supplies program-with-interrupt audio that is routed to the headphone output’s left channel. Channel 2 of the IFB circuit supplies

program-only audio that is routed to the right channel. Line input 1 is connected to an audio source associated with a sports-event “spotter” position. This source is routed to the headphone output’s right channel. The input trim pot associated with line input 1 can now serve a critical role—adjusting the relative level of the “spotter” audio as compared to the level of IFB channel 2. The trim pot allows the desired “mix” to be created, providing the user with an effective cue signal.

Talkback-to-Intercom Sidetone Adjustment

Associated with the talkback-to-intercom functions are sidetone trim potentiometers that are used to adjust the talkback levels that are being returned to the intercom line receive audio sources. These two trim pots are part of the analog hybrid circuit that separates (“nulls”) talkback audio from receive (“listen”) audio. If audio from either or both of the intercom channels is to be used as a headphone source, and talkback to these intercom channels is also desired, the sidetone trim pots may need to be adjusted.

One trim pot is associated with the sidetone level for each channel of the intercom interface. Both are accessible on the bottom of the Model 230’s enclosure, adjacent to the trim pots associated with the line-level inputs. Adjusting them is very simple, requiring only a pair of ears and a screwdriver.

With the Model 230 configured as previously described, activate one of the talkback-to-intercom functions. Audio from the connected microphone should be heard in the configured headphone output channel(s). Adjust the trim pot associated with the active intercom channel so that

the desired sidetone level, relative to the intercom receive level, is achieved. The adjustment range is approximately 18 dB, with the sidetone level increasing as the trim pot is rotated in its clockwise direction. Now change to the other intercom channel and adjust its sidetone trim pot as desired.

Using the Model 230’s sidetone function, talkback audio will be routed to the headphone outputs by means of dedicated circuitry. If this is enabled be certain to place the two intercom sidetone trim pots to their fully counterclockwise positions. This will minimize the increase in sidetone level that will occur when both the sidetone and talkback-to-intercom functions are active. Additional details are provided later in this user guide.

Technical Notes

Grounding and Shielding

As previously discussed in this user guide, the pin 1 connections on the main and line-level talkback outputs’ 3-pin male XLR connectors are “floating,” i.e., not connected to anything within the Model 230’s enclosure. Some audio experts might take offense to this, complaining that this should have been left to the user or installer to be connected or disconnect as desired. However, repeated field testing found that floating pin 1 on these outputs was the key to maintaining quiet audio. From Fenway Park in Boston, to the Orange Bowl in Florida, and then northwest to Husker Stadium in Nebraska, lifting pin 1 did the trick.

A simple solution is available if an application does require that a ground be available on the main and line-level

talkback outputs' interconnecting cables. All Model 230 XLR connectors have a ground connection that is made to the interfacing connector's metal "shell." And most XLR connectors have a pin or connection point available to access its metal shell. By connecting the cable shield to the mating connector's shell terminal, the common connection typically found on audio interconnections is created.

IFB Channel Crosstalk

By the very nature of its design, a standard "wet" IFB circuit is prone to exhibit cross-talk between its two audio channels. This occurs because the audio paths are unbalanced ("single-ended") and typically transported on a single shielded twisted-pair audio cable. The primary cause of the crosstalk is the capacitance between the wires in the cable pair. The greater the capacitance, due to cable type and length, the more crosstalk there will be. It's not surprising to find in sports broadcasting venues that audio from one channel in an IFB circuit can be heard "bleeding" into the other channel. Does this generally create a problem? No, as each channel in an IFB circuit generally carries related audio content. For example, on-air talent hearing in their left ear a small amount of program audio from channel 2 while an interrupt from channel 1 is active, typically wouldn't perceive this as an issue.

There are several ways of reducing IFB channel crosstalk. Probably the easiest way is to use cable pairs that are not twisted. Twisted pairs are great for differential (balanced) signals, but not so great for unbalanced transmission. This is generally because the more twists in a pair the greater the effective cable capacitance. In a stadium or arena setting, choosing

standard "telco" pairs may actually work better than "high-performance" audio or data cable!

Another option is to use two cable pairs for each IFB circuit. If the pairs are not shielded the wiring is simple. Common would be connected to one side of each pair, and then signal from each channel would connect to the other side of the pairs. If the pairs also contain shields the wiring could be done somewhat differently. One option is to connect common to both cable shields, IFB channel 1 (DC with audio) to one full pair, and IFB channel 2 to the second full pair. A better option might be to have common connect to both shields and one side of the pair that serves IFB channel 2.

Other options are available if an application demands low crosstalk. If resources in the broadcast or production facility allow one method would be to run the IFB circuits "dry" (no DC) and differential (balanced). This would gain the benefits of differential transmission, including minimizing the crosstalk. The balanced line-level signals can be directly connected to the Model 230's line inputs. However, if it's desired to connect cue sources to the Model 230 using an IFB circuit, the line-level audio signals will need to be "wetted up" into standard IFB circuits. This is easily accomplished using one of several high-performance IFB interface units from Studio Technologies. For further information please refer to the Studio Technologies website.

The discussion in the previous paragraphs concerning IFB circuits can also apply to single- and dual-channel intercom lines. The same type of cabling is typically used for both, resulting in the same crosstalk issues. However, by their very nature as

“party line” systems, inter-channel cross-talk on intercom lines should not prove to be a problem. With multiple intercom stations and beltpacks active at the same time, the noise level and user voices present on these lines should mask any cross-talk that occurs.

IFB Audio Levels

The Model 230 is designed to operate best with IFB audio levels that are nominally -10 dBu. This is the nominal level of most IFB systems, such as provided by the Studio Technologies' Models 41 and 42A. But actually having the correct level present on an IFB circuit is often a “hit-or-miss” proposition. During field testing of prototype announcer's consoles, Studio Technologies' personnel found that a wide range of nominal audio levels were present on “real-world” IFB circuits. Many were fine, being reasonably close to the desired -10 dBu. But some were much too low, while others were much too “hot.” We observed one unfortunate baseball “color” commentator being sent interrupt audio signals so “hot” relative to program audio as to almost make his ears bleed! This situation should not have been allowed to happen.

In defense of field technical personnel, measuring the audio level of an IFB circuit hasn't traditionally been an easy proposition. But that situation has now changed. After experiencing this condition in the “field,” Studio Technologies' engineers were motivated to design the Model 72 Level Meter/Interface. This compact device plugs directly into an IFB circuit and provides two useful functions: level meters and “dry” audio outputs. Two 5-segment LED meters allow direct observation of the audio signal levels present on the IFB circuit. The display range is optimized for

the signal levels found on typical “wet” IFB circuits, rather than traditional “VU” scaling.

The Model 72 also provides two transformer-coupled “dry” audio outputs, one for each IFB channel. These outputs are useful for a variety of production and testing applications. For example, the outputs can serve as the interface between a traditional “wet” IFB system and a wireless in-ear monitor system. The outputs can also be connected to a monitor panel, allowing visual and aural monitoring of the IFB audio signals.

In conclusion, we're sorry for this shameless promotion of the Model 72 Level Meter/Interface! But necessity was definitely the “mother” when it came to the unit's invention. Working “in the field” without such a device, we felt “blind” when connecting to IFB circuits. That no longer has to be the case and we think that you'll find owning one a very worthwhile investment. For further information please refer to the Studio Technologies website.

Intercom Audio Levels

The Model 230 was designed to function well with intercom circuits associated with standard broadcast and production party-line intercom systems. These systems provide DC power and one or two channels of audio over standard 3-conductor cables that terminate with 3-pin XLR connectors. Establishing the correct “listen” and “talk” levels was critical in achieving good audio performance. In North America the two most common intercom systems are those from RTS and Clear-Com. From tests performed in Studio Technologies' lab, the nominal RTS TW-series audio level is approximately -10 dBu. The dynamic range control provided by beltpacks such

as the BP325 was very good, limiting the maximum level to at most 10 dB above the nominal. The nominal audio level associated with a Clear-Com system was harder to characterize. It appeared to be a few dB less than -10 dBu, but the dynamic range was much larger. Level peaks of 10 to 20 dB over nominal were easy to produce.

This objective data led to the following Model 230 design decisions. When audio from intercom channels 1 and 2 was used as headphone cue sources, level sensitivity selection switches or trim pots were not required. The level-range available on the Model 230's front-panel controls proved to be sufficient for the user to be able to establish the desired listening level. When talkback audio was routed to the intercom channels a fixed level for use with both RTS and Clear-Com systems also proved to work well. This was mainly possible due to the excellent dynamic-range-control provided by the compressor circuit. Its threshold (2 dB above Model 230 internal nominal level) and compression ratio (5:1) resulted in excellent talkback-to-intercom audio. So in the end, no level or compatibility switches of any kind were required to achieve the desired "listen" and "talk" performance.

The above paragraphs may elicit howls of protests from a host of engineers and intercom system experts. But for years we've heard differing reports as to the actual nominal audio levels for RTS and Clear-Com systems. The "in-the-know cats" agreed that RTS TW intercom (and IFB) was -10 dBu, a value that we confirmed in our tests. But the nominal level for Clear-Com was variously reported as -20, -15, -12, -10, and "you know, the

Clear-Com level!" It's most likely that early Clear-Com systems did use a nominal level in the -20 dB range. But after making controlled tests, the contemporary equipment seemed to be much closer to -10 dBu. And with the limited dynamic-range control that we experienced, the actual level during operation may vary widely. That's why intercom interface sensitivity, compatibility switches, or rotary controls were not included in the Model 230. But just in case a change is ever required, key intercom interface gain levels are set using socketed resistor pack devices.

In conclusion, the engineers at Studio Technologies are always open to learning more. Additional information from the field concerning such topics as intercom system levels, impedance matching, and DC power sourcing would be welcomed. Stopping by our offices for an in-person chat would be also great. (And bringing along pizza and beer for a tech-talk session would certainly get our attention!) Just park the production trailers on the street!

Phantom Power

The Model 230 provides a 48 volt nominal source of phantom power to support condenser microphones. It's designed to meet the P48 requirements as specified in the IEC 61938 standard. The circuitry is very simple: 6.85 k ohm resistors provide a path from a 45 volt DC source to pins 2 and 3 of the microphone input connector. The resistors and the power source work together to provide the required 48 ± 4 volts, up to a maximum current of 10 milliamperes.

Symptoms of Insufficient Power

A core part of the Model 230's internal circuitry is a switch-mode power supply that produces +45 volts, +12 volts, +5 volts, and -12 volts. This power supply circuit works very well as long as it is "fed" with sufficient input voltage and current. "Sufficient" is defined as a minimum of 24 volts on the IFB input and 20 volts on the external 24 volt DC input. The necessary current, 125 milliamperes for the IFB circuit and intercom line and 90 milliamperes for the external source, must be supplied over their respective voltage ranges.

It's worth discussing what will happen if any of these power sources fall below their specified minimum. Typically, if the Model 230 is being powered by an external 24 volt nominal power source, normal operation will continue until the input falls to the 18-20 volt range. As the input voltage drops below this range the Model 230's internal power supply will have reduced stability, operating in this manner until its low-voltage shutdown circuit halts operation. Note that as the input voltage moves down from 24 volts the input current will rise proportionately to make up for the loss of power.

Using the intercom line to provide Model 230 power shouldn't prove to be a problem. Power supplies associated with broadcast and production intercom systems are designed to support multiple beltpack and related devices. In the "big scheme of things," connecting a Model 230 shouldn't add a significant load.

If an IFB circuit is powering the Model 230, maintaining the required voltage and current is more critical. Should the voltage or current fall below the specified minimum,

the Model 230's power supply circuit will again become unstable. This will become an issue as noise will be induced into the IFB circuit's audio signals. The reason is simple: an IFB circuit "multiplexes" 3-conductors so that they carry both power and audio signals. If sufficient amounts of voltage and current are supplied to the Model 230's IFB input, the Model 230's power supply will draw a steady amount of energy. This will not disturb the analog signals on pin 1 (common for DC and audio) and pin 2 (DC and channel 1 audio). But if the Model 230's power supply is not supplied with sufficient energy (volts multiplied by amps) it will try to draw what it needs from the IFB circuit, becoming unstable in the process. The IFB circuit's audio signals will be corrupted by the power supply's attempt to draw enough power. Instead of nice clean audio there will be squeaks, squeals, and some awfully funky noises added. Again, in a low-voltage or low-current situation, no damage will be done to the Model 230's circuitry but correct operation will not be possible.

In most cases maintaining the IFB circuit's required voltage and current shouldn't be a problem. But issues may arise due to malfunctioning IFB circuit sources or poor interconnect cabling. Typically, excessive cable length won't be the cause of a problem. Generally, problems will be caused by broken or damaged connector pins, dirty patch points, or damaged (partially open) cable conductors. Measuring the IFB circuit's voltage and current draw directly at the Model 230's IFB input connector will quickly identify if there's a power issue.

And now for another shameless "plug" for other Studio Technologies products: Frankly, most devices that supply IFB circuits for broadcast applications use outdated

technology that provides mediocre performance. That's why Studio Technologies developed high-performance IFB interface units. These products do an excellent job of providing power and audio to connected devices such as the Model 230. However, unlike other products, the power supplied by the IFB circuits created by these units maintains their output voltage all the way to their full rated current. The result is being able to power more devices over longer cable runs. In addition, the audio quality of these units is superior. For further information please refer to the Studio Technologies website.

LED Colors

As previously described, two LED indicators are associated with the main output and are located directly above the main output pushbutton switch. The red LED, located on the left, is lit whenever the main output is muted. The green LED, located on the right, is lit whenever the main output is active. The thought process behind the color choices was that red would relate to the main output being muted ("stop") while green would relate to the main output being active ("go"). It's possible that these color choices may not meet the needs of all users and applications. For example, it's reported that one European broadcaster typically uses these two colors in the opposite fashion. Their choice is to have the red LED lit whenever the main output is active, warning the talent that they are "on-air." The green LED is lit whenever the main output is muted, indicating to the talent that it's "safe" to say whatever they wish, about whomever they wish to say it about!

For consistency, the LEDs associated with the talkback buttons were selected to be

green. They light whenever their associated talkback functions are active. It's possible that some applications may benefit from revising these LED colors too. While red is certainly one possible choice, other colors are also a possibility, including amber, orange, blue, or white—these days there are lots of choices available.

A qualified technician can easily revise the LED colors to meet an application's exact needs. The process would begin by disassembling the Model 230's enclosure and detaching the pushbutton/LED printed circuit board assembly. The LEDs would then be unsoldered, removed, and reinstalled (or replaced) in the desired locations. To control the LED current and set the brightness, a 825 ohm 1206-size surface-mount resistor is electrically in series with each LED.

For additional information about changing the LED colors, please contact Studio Technologies' technical support.

Travel Case

For portable applications it may be desirable to store and transport each Model 230 in a protective case. After much travel with prototype announcer console units, Studio Technologies personnel learned to appreciate the Pelican Model 1450 case. Purchased with the foam interior option, it does an excellent job of holding one Model 230, its associated 24 volt DC power supply, and documentation. Some applications may benefit from selecting a larger case that would also hold a related headset, cables, etc. A larger case could also be selected that would hold multiple Model 230 units. Pelican sells their products through a dealer network, many of which can be located via a web search.

Connecting Line-Level Audio to the IFB Input

In “emergency” situations it’s possible to connect line-level audio signals directly to the Model 230’s IFB input connector. This can be successfully done as long as several limitations are taken into account. The first limitation is that the 10 k ohm input circuit presents an unbalanced load to the source. In most cases this shouldn’t pose a problem. If a balanced interconnection scheme must be maintained an in-line isolation transformer can be used. A second limitation is that the audio level presented to pin 2 (IFB channel 1) must not exceed 0 dBu or signal “clipping” may occur. Prepare a 3-pin male XLR connector so that the line-level audio source designated as IFB channel 1 is connected with signal high on pin 2 and low/shield on pin 1. The audio source designated as IFB channel 2 should be connected with signal high on pin 3 and low/shield on pin 1. With this connection scheme the nominal input level is –10 dBu, the same as with an IFB circuit. This may require that an external attenuator (“pad”) be used to reduce the level of the connected signal. As expected, powering the Model 230 in this scenario will require an intercom line or external source of 24 volt DC to be connected.

Additional Connectors

Three spare connector locations are provided on the Model 230’s back panel. From the factory they contain blank plates that can be readily removed and replaced with a variety of XLR connectors. These spare connector locations are specifically included so that a Model 230 can be customized to meet the many specific needs that arise in broadcast and related audio

applications. Expected uses for these locations include adding a 5-, 6-, or 7-pin XLR connector to allow direct connection of a broadcast headset. Other uses include creating “loop through” or “mult” functions for the line-level talkback output, IFB input, or intercom interface connections.

The spare connector locations are compatible with the Neutrik DL-series of connectors. For flexibility, versions are available that provide from three to seven contacts. For example, a compatible 3-pin female connector would be Neutrik part number NC3FD-L-1. To support headsets the NC6FDS-L-1 is often used. This is a 6-pin female connector with the unique Switchcraft 6-pin arrangement. The hardware that secures the blank plates to the Model 230’s back panel is also intended to secure the replacement connectors.

If connectors are added to the Model 230’s spare connector locations adding labels to those connectors can be helpful. For a great look it is recommended that Brother® P-Touch ¼-inch (6 mm) labels be created. Tape material that prints white text on a black background works out well for the Model 230. The Brother label cassette number TX-3151, white on black, is appropriate for use with many of their printers.

In addition to the spare connector locations on the back panel, provision has been made to allow easy interconnection with the Model 230’s printed-circuit-board-mounted input and output connectors. This was accomplished by including numerous 3-position male “header” connectors on the Model 230’s circuit board. These headers, on 0.1-inch centers, are wired in parallel with the Model 230’s connectors. This “no solder” solution makes customizing a Model 230 a simple process. The headers, located on the Model 230’s printed

circuit board, are Molex® part number 22-23-2031. They mate with Molex housing number 22-01-3037. To make the interconnection, separate crimp terminals are attached to loose wires and then “snapped” into the housing. Molex part number 08-50-0114 specifies crimp terminals that are appropriate for wires of 22 to 30 gauge. These parts are available worldwide from sources such as Digi-Key, website www.digikey.com.

To make the process of connecting to the Model 230’s headers a simple task an interface cable kit, part number 31087, is available from Studio Technologies. Each kit includes five cable assemblies and a length of heat-shrinkable tubing. Each cable assembly consists of a mating connector with three color-coded wires attached. These wires, approximately 12 inches in length, allow convenient soldering to a connector slated to be installed in a spare location on the Model 230’s back panel. For reference, the wire color for pin 1 is gray, pin 2 is yellow, and pin 3 is blue.

The heat-shrinkable tubing is provided so that the connector solder cups can be insulated from each other. It will also provide some strain relief to the solder joints. Be certain to slip the desired length of tubing over the wire prior to soldering a connection! (If the writer had a dollar for every time he forgot to put tubing on a wire (or slip on a connector shell) before making a solder connection...)

The Model 230’s enclosure must be disassembled prior to installing connectors in the spare locations. Four hex-head machine screws, two on the bottom front of the enclosure and two on the back panel, must be removed. A 5/64-inch hex driver is required. The cover can then be

carefully separated from the chassis, remaining attached by means of a flexible cable assembly. This “flex-cable” assembly links the main printed circuit board assembly with the board assembly that contains the pushbuttons and LED indicators. Ensure that the flex cable is not damaged while the Model 230 is being customized. For easier access, the pushbutton/LED board assembly can also be easily removed.

The 3-position headers on the Model 230’s main circuit board assembly are located close to their related input or output connectors. The following list provides the printed circuit board reference numbers and associated functions.

P3: External 24 Volt DC Input, pin 1 common, pin 2 +24 volts, pin 3 not used. Back-panel 2.1 x 5.5 mm jack has +24 volts on center pin. Header P12 is used by the back-panel 24 Vdc jack assembly and is electrically in parallel with P3.

P4: Headphone Output, pin 1 common, pin 2 tip (left), pin 3 ring (right).

P5: Microphone Input, pin 1 shield, pin 2 high, pin 3 low. Follows back-panel 3-pin female XLR pin assignment.

P6: Main Output, pin 1 shield, pin 2 high, pin 3 low. Careful! Back-panel 3-pin male XLR has pin 1 floating, pin 2 high, pin 3 low.

P7: Line-level Talkback Output 1, pin 1 shield, pin 2 high, pin 3 low. Careful! Back-panel 3-pin male XLR has pin 1 floating, pin 2 high, pin 3 low.

P8: Line Input 1, pin 1 common, pin 2 high, pin 3 low.

P9: Line Input 2, pin 1 common, pin 2 high, pin 3 low.

P10: IFB Input, pin 1 common, pin 2 DC with channel 1 audio, pin 3 channel 2 audio. Follows back-panel 3-pin female XLR pin assignment.

P11: Intercom Interface, pin 1 common, pin 2 DC with channel 1 audio, pin 3 channel 2 audio. Follows back-panel 3-pin female XLR pin assignment.

Additional functions can be accessed using these 3-position headers:

P13: Talkback-to-Intercom Channel 2 “Dry” Output, pin 1 common, pin 2 audio, pin 3 not used.

P14: Talkback-to-Intercom Channel 1 “Dry” Output, pin 1 common, pin 2 audio, pin 3 not used.

P15: Auxiliary Relay Contact B, pin 1 normally closed, pin 2 common, pin 3 normally open.

P16: Auxiliary Relay Contact A, pin 1 normally closed, pin 2 common, pin 3 normally open.

P17: Internal Power Supply Rails, pin 1 common, pin 2 +12 Vdc, pin 3 –12 Vdc.

P18: Remote Switch Connections, pin 1 common, pin 2 main out button, pin 3 aux (currently not supported in software).

P19: Remote Switch Connections, pin 1 common, pin 2 talkback button 1, pin 3 talkback button 2.

P23: Internal Power Supply Rails, pin 1 common, pin 2 +12 Vdc, pin 3 –12 Vdc.

Remote Control Connections

Provision has been made on the Model 230's printed circuit board assembly to allow external switches or contact closures to control the main out and talkback button functions. Two 3-position headers

provide access to the circuitry associated with the functions.

P18: Remote Switch Connections, pin 1 is connected to the common point of the Model 230's circuitry. Pin 2 is connected to the circuitry associated with the main out pushbutton. Pin 3 is connected to the circuitry associated with the auxiliary pushbutton input. (This function is not currently supported in software.)

P19: Remote Switch Connections, pin 1 is connected to the common point of the Model 230's circuitry. Pin 2 is connected to the circuitry associated with the talkback 1 button. Pin 3 is connected to the circuitry associated with the talkback 2 button.

The input circuitry is “active low,” with a 10 k ohm resistor connected to +5 volts acting as a pull up. A combination of resistors and capacitors provide ESD protection. A qualified technician can use these inputs for special applications. Contact the factory for additional details.

Compressor Circuit

In this section some general information about the Model 230's compressor circuit will be provided. As previously discussed, the output of the microphone preamplifier circuit is connected to a studio-quality compressor circuit. The output of the compressor is used by the talkback functions and, if the unit has been modified, the main output. (In most cases the main output will utilize the signal coming directly out of the microphone preamplifier.) The gain element in the compressor circuit is a laser-trimmed voltage-controlled-amplifier integrated circuit. It provides accurate, low-noise, low-distortion performance. The threshold of the compressor circuit is 2 dB above

the Model 230's nominal internal operating level of -2 dBu. A 5:1 compression ratio is implemented and, like the threshold level, is not field adjustable. The threshold and ratio settings were selected so that excellent talkback audio would be provided. By controlling the dynamic range, intelligibility can be improved and overloading of connected devices can be avoided. An LED indicator lights whenever the compressor's threshold has been reached and the circuit is actively controlling the dynamic range. This LED is provided as an aid when setting the gain of the microphone preamplifier.

Auxiliary Relay

The Model 230 provides an auxiliary relay for use in specialized applications. Some "head scratching" or "brainstorming" should lead to a number of interesting ways to take advantage of this unique resource. To implement any auxiliary relay application does require the services of a qualified technician. This is because the Model 230's enclosure must be disassembled and the desired wiring scheme implemented. The relay operates under software control, following the configuration selected using two of the DIP switches. Four operating modes are available: relay disabled, relay follows main output status, relay follows talkback 1 status, and relay follows talkback 2 status. These choices were previously discussed in this user guide and should be reviewed.

The relay provides two "form-C" contacts, each consisting of a common, normally open (not shorted), and normally closed (shorted) connection. Obviously the two form-C contacts change state in unison; two independent relay functions are not provided. These relay contacts are accessible on the Model 230's main printed circuit

board assembly by way of two 3-position header connectors. The contacts are titled A and B, but there is no significance between the two. With both headers pin 1 is normally closed, pin 2 is common, and pin 3 is normally open. For additional details on connecting to the 3-position headers please refer to the Additional Connectors section in the Technical Notes area of this user guide.

Main Output Source Selection

From the factory the Model 230 is configured so that the output of the microphone preamplifier is the audio source for the main output. For most on-air applications this is the desired source. It will provide the most natural audio quality with the potential for a large amount of dynamic range. The output of the microphone preamplifier is also connected to the input of the compressor circuit. The output of the compressor circuit supplies audio to the talkback functions. Controlling the dynamic range of the talkback audio signals can minimize the chance of cable crosstalk and equipment overload in non-on-air signal chains.

But in the audio business exceptions often turn out to be the rule. In some very special applications it may be desirable for the output of the compressor circuit to be routed to the main output. This could be especially true when the Model 230's system mode is selected for production and the main output is serving as an additional talkback function. A "hidden" feature allows the main output's audio source to be changed. From the factory, the output of the microphone preamp is routed to the main output by way of a 1 ohm resistor "jumper" soldered into the Model 230's printed circuit board assembly. An alternate component location is also included

to allow the output of the compressor to serve as the source. With these simple provisions a qualified technician can move the surface-mount resistor and achieve the desired audio-source change. As the process does require soldering and “board level” component work, electing to make the change must be approached with care. Contact the factory for additional details.

Additional Line-Level Output

The two talkback buttons on the Model 230 allow talkback audio to be routed to one line-level output and one or two channels associated with an intercom line. However, there may be applications where it would be helpful to have a second line-level output. The Model 230 has made provision to accomplish this using an optional line output card. This card, available from Studio Technologies and purchased separately (part number 31086), is mounted into a spare connector location located on the Model 230's back panel. Audio “drive” for the card comes from the circuitry associated with the talkback-to-intercom functions. Due to this circuitry's design, the nominal output level of the line output card is -10 dBu. Two 3-position header connectors, located on the Model 230's main printed circuit board assembly, provide access to talkback-to-intercom channel 1 and channel 2 audio signals.

The line output card contains passive circuitry, including a 3-pin male XLR connector and a 600 ohm to 600 ohm isolation transformer. Capacitors in series with the transformer's output provide protection against damage in case DC power is present on a connected cable. In series with the output are 300 ohm resistors, making the effective output impedance

approximately 600 ohms. These resistors can be used to create a passive summing network.

A line output card kit contains a printed circuit board assembly, an interconnecting cable, and hardware. Installing the kit is very simple. The 3-pin male XLR connector is mounted in one of the spare connector locations on the Model 230's back panel. This secures the connector and associated printed circuit board to the enclosure. The interconnecting cable is then used to link the card and the Model 230's main printed circuit board assembly. One end of the cable is plugged into the card's 3-position “header” that is labeled IN. The other end of the cable is plugged into the desired 3-position header located on the main printed circuit board assembly. The header associated with talkback-to-intercom channel 1 is labeled P14. The header associated with talkback-to-intercom channel 2 is labeled P13.

Note that the unused header remaining on the line output card has its pins “muled” with the leads on the 3-pin male XLR connector. It is provided for other applications that may need it. Additional installation details are provided in the Additional Connectors section of the user guide. A recommended connector labeling method is also included.

Interface cables intended for connection to balanced loads should be wired so that signal high (+ or hot) is connected to pin 2, signal low (- or cold) is connected to pin 3, and shield is connected to pin 1. For unbalanced loads the connector should be wired so that signal high is on pin 2, and signal low/shield is connected to both pins 1 and 3. If this results in hum or noise, try connecting signal high to

pin 2, signal low/shield to pin 3, and leave pin 1 left unterminated (“floating”).

Several things are worth mentioning. As previously discussed, the nominal output level of this additional line-level talkback output is -10 dBu. This is significantly less than the nominal level of the Model 230’s line-level talkback output. The audio quality is similar, only the level is different. Also note that if a line output card is installed its output, as well as its associated talkback-to-intercom channel, will always operate in tandem. Independent control is not possible, nor should it be required.

Direct Microphone Output

The Model 230’s main output is intended to be used as the on-air, stadium announcement, or other primary audio feed. The path from the unit’s microphone input connector to the main output connector is by way of active circuitry. A low noise, low distortion microphone preamplifier stage, “clickless” audio switching, and a high-quality transformer-coupled output circuit work together in achieving excellent performance. The nominal level of the main output is -2 dBu, allowing interconnection with related devices at a near-standard “line” level. However, there may be applications where an output that directly relates to the connected microphone would be beneficial. The Model 230 has made provision to accomplish this by using the optional direct microphone output card. This card, available from Studio Technologies and purchased separately (part number 31058), is mounted in a spare connector location available on the Model 230’s back panel. With this addition both an “active” main output and a “passive” direct microphone output will be available.

Of course, both outputs provide quiet noise-free on/off (“muting”) control.

The primary application for the direct microphone output is when the Model 230 is integrated into a system that includes a high-performance microphone preamplifier. This preamplifier may be part of a stand-alone voice-processor unit, or a microphone input associated with an audio console. Engineering personnel may prefer the sonic characteristics of the external microphone preamp over that of the one integrated into the Model 230.

It’s important to note that the direct microphone output card provides a direct “metallic” path from the microphone input to the external preamplifier circuitry. It is not simply an audio “pad” (attenuator) that reduces the level of the main output from “line” to “mic.” The Model 230’s auxiliary relay contact, along with circuitry on the direct microphone output card, provide click-free muting of the signal.

The direct microphone output card contains only passive circuitry. A 3-pin male XLR connector is provided for the output signal. A resistor and large electrolytic capacitor form the muting circuit. This arrangement allows muting to take place without disturbing phantom-power that may be enabled to support a condenser microphone. The direct microphone output card also contacts two 3-position header connectors. These interface with “headers” on the Model 230’s main printed circuit board assembly, providing access to the microphone input connector and auxiliary relay contact.

The direct microphone output card kit contains a printed circuit board assembly, two interconnecting cables, and mounting

hardware. Installing the kit is very simple. The card's 3-pin male XLR connector is mounted into one of the three spare connector locations on the Model 230's back panel. Specifically, the connector location that is closest to the microphone input connector should be used. The two screws, with associated locking nuts, are used to secure the connector and associated printed circuit board to the enclosure. The interconnecting cables are then used to link the card with the Model 230's main printed circuit board assembly. One end of the first interconnecting cable is plugged into the card's 3-position header that is labeled MIC. The other end of this cable is plugged into the 3-position header associated with the microphone input connector, labeled P5, located on the main printed circuit board assembly. One end of the second interconnecting cable is plugged into the card's header that is labeled RELAY. The other end of this cable is plugged into the header associated with the auxiliary relay, labeled P16, located on the main printed circuit board.

After the direct microphone output card has been installed, one configuration step must also be performed. Using the configuration switches, located on the bottom of the Model 230's enclosure, the auxiliary relay control mode must be set to the "follows main output status" position. This provides the on/off (muting) control of the direct microphone output signal. Should the auxiliary relay's configuration be left in the "relay disabled" position, the direct microphone output will always be in the off (muted) state. It's interesting to note that the recommended auxiliary relay configuration assumes that the direct microphone output will be used in place of the Model 230's main output. However,

for other applications there is certainly no reason why the direct microphone output can't be configured to follow the status of one of the talkback buttons. Special situations may benefit from having a microphone signal that is active only during "talkback."

Using the direct microphone output is essentially the same as connecting directly to a microphone. An interface cable should be wired so that signal high (+ or hot) is connected to pin 2, signal low (- or cold) is connected to pin 3, and shield is connected to pin 1. When connecting a condenser microphone it's recommended that the Model 230 provide the source of phantom power. In this way the microphone will stay active whenever the Model 230 is operating, even if the connection made to the direct microphone output is broken. By ensuring that the microphone remains active, the talkback functions will continue to operate correctly.

Two slight differences between connecting to a stand-alone microphone and connecting to the Model 230's direct microphone output should be noted. The first is that pin 1 on the direct microphone output's 3-pin male XLR connector is electrically isolated from pin 1 on the Model 230's 3-pin female XLR microphone input connector, as well as the Model 230's signal common/chassis connection. This is intended to minimize the chance of "ground loops" being created. Contact the factory should assistance in this area be required.

The second difference is that while the circuitry between the microphone input and direct microphone output is entirely passive, it will still impact the microphone signal. The impact is benign but is still worthy of description. The circuitry associated with the Model 230's microphone

preamplifier and phantom power supply is always connected across (“bridged onto”) the microphone input. This adds a 2 k ohm essentially resistive load to the microphone, something that should have no sonic impact. In some cases this may reduce the microphone signal level by less than one dB. Also, two 150 ohm resistors are electrically connected in series between the microphone input connector and the direct microphone output connector. These resistors provide isolation, allowing the direct microphone output to be muted while still maintaining microphone audio on the Model 230’s preamplifier input. This audio is necessary so that the talkback functions can continue to operate. The series resistors will have minimal impact, simply raising the microphone’s apparent source impedance as “seen” by the external preamplifier.

Pushbutton Backlighting

For special applications, provision has been made to allow LED illumination (“backlighting”) of the three pushbutton switches. This may prove useful for applications where adequate room lighting is not available. It can also serve in custom Model 230 configurations. It’s important to note that the button lighting is not intended to serve tally applications. It is strictly intended to provide a moderate amount of illumination of the button’s clear lens and associated labeling.

From the factory, LED lamps are not installed in the pushbutton housings. The socket in each housing was designed for inserting a pluggable T-1 bi-pin incandescent type but we find that the more modern leaded T1 LEDs work very well. The Model 230’s 5 volt DC power supply is

connected to the socket in each pushbutton housing by way of 2.2 k (2200 ohm) resistors. With this implementation, along with the recommended LED, only 1 milli-ampere per LED is consumed.

It’s intended that high-efficiency white LEDs be installed. They use very little DC current and have essentially infinite life. The recommended LED is the Kingbright WP7104QWC/D which as of the time of this writing is available from sources such as Digi-Key (www.digikey.com) and Mouser Electronics (www.mouser.com).

The mating socket in each pushbutton assembly is accessed by removing the button’s lens caps, graphic label, and back frosted lens. Once this is done installing the LED should be very simple, requiring only lead trimming and careful insertion. Begin by removing the top clear lens, label, and frosted under-lens in each pushbutton. Trim the LED leads to 0.25 inches in length and insert into the sockets with the cathode end located nearest the front of the Model 230. Power up the Model 230 and observe if the LEDs light. The LEDs are polarity sensitive and if one or more of them do not light, remove the offending LED(s), rotate them 180 degrees, and then re-insert.

Specifications

General Audio (Mic In-to-Main Output):

Frequency Response: 10 Hz-20 kHz, ± 0.2 dB, mic in/main out

Distortion (THD+N): 0.008%, measured at 1 kHz, mic in/main out

S/N Ratio: 86 dB, referenced to -42 dBu mic in/ -2 dBu main out

Dynamic Range (A-weighted): 108 dB

Connectors:

Mic In, Line In 1 & 2, IFB In, Intercom Interface: 3-pin female XLR

Main Out, Talkback Out: 3-pin male XLR

Headphone Out: 1/4-inch 3-conductor phone jack

24 Vdc Power In: 2.1 x 5.5 mm coaxial power jack with locking bushing, compatible with Switchcraft S760K plug

Spare Connector Locations: 3

Allows up to three Neutrik NC*D-L-1 connectors to be installed (*=3F, 3M, 5F, 5M, 6F, 6FS, etc.)

Microphone Input/Preamplifier:

Type: electronically balanced

Input Impedance: 2 k ohms

CMRR: > 80 dB, 20 Hz-20 kHz, 40 dB gain

Gain Range: 20 to 60 dB, nominal, adjustable in 10 dB steps; 0 dB (no gain) also available

Compatibility: dynamic or phantom-powered mics

Phantom Power: 48 Vdc, nominal, meets IEC 61938 P48 standard

Compressor:

Threshold: 2 dB above nominal level

Attack/Release Time: 2 mSec/100 mSec

Slope: 5:1

Status LED: compressor active

Line Inputs: 2

Type: balanced, transformer-coupled

Impedance: 10 k ohms

Nominal Level: -12 dBV to $+6$ dBu, adjustable

IFB Input:

Type: 2-channel, unbalanced (pin 1 common; pin 2 DC with channel 1 audio; pin 3 channel 2 audio)

Impedance: 10 k ohms

Nominal Level: -10 dBu

Intercom Interface:

Type: 2-channel, unbalanced (pin 1 common; pin 2 DC with channel 1 audio; pin 3 channel 2 audio)

Compatibility: single- and dual-channel intercom systems such as from RTS™ and Clear-Com®

Impedance: 10 k ohms

Nominal Receive Level: -10 dBu

Nominal Talkback Level: -10 dBu

Sidetone: 0 to -18 dB, adjustable

Pin 2 Minimum Voltage: > 18 Vdc for headphone monitoring of pin 2 and pin 3 intercom audio

Main Output:

Type: balanced, transformer-coupled

Nominal Level: -2 dBu

Maximum Level: $+20$ dBu into 2 k ohms

Impedance: 100 ohms

Line-Level Talkback Output:

Type: transformer-coupled with series capacitors and isolation resistors

Impedance: 600 ohms

Nominal Level: $+4$ dBu

Maximum Level: $+11$ dBu (compressor restricts maximum)

Headphone Output: 1, stereo

Compatibility: intended for connection to mono or stereo headphones or headsets with nominal impedance of 100 ohms or greater

Type: voltage driver

Maximum Output Voltage: 12 Vpp, 150 ohm load

Auxiliary Relay:

Function: software configurable

Contacts: 2, form C (Common, Normally Closed, Normally Open)

Rating: 1 A, 30 W (resistive)

Access: requires user-implemented connector scheme

Power Sources:

IFB Input: 24-32 Vdc, 125 mA

Intercom Interface: 24-32 Vdc, 125 mA

External: 24 Vdc, 90 mA @ 24 Vdc; acceptable range 20-30 Vdc. Each unit shipped with a universal input/24 Vdc output power supply.

Options: direct microphone output card, line-level output card

Dimensions (Overall):

8.1 inches wide (20.6 cm)

3.3 inches high (8.4 cm)

8.5 inches deep (22.4 cm)

Weight: 4.5 pounds (2.1 kg)

Specifications and information contained in this User Guide subject to change without notice.

Appendix A

Attached to the bottom of the unit is a security plate with text that provides a summary of the configurable parameters and related information.

Model 230 Configuration Settings

For full documentation go to www.studio-tech.com

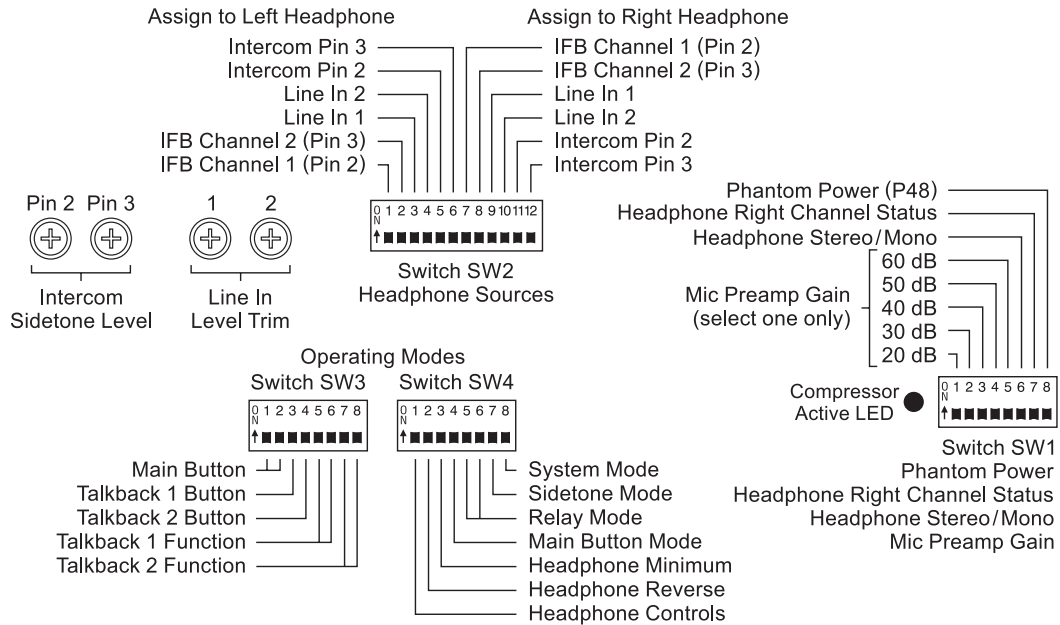

- Main Button**
- ▼▼ Push to Mute
 - ▲▲ Push to Talk
 - ▼▲ Latching
 - ▲▲ Hybrid

- Talkback 1/2 Button**
- ▼ Push to Talk
 - ▲ Hybrid

- Talkback 1/2 Function**
- ▼▼ Disabled (Relay Only)
 - ▲▼ Line-Level Talkback Out
 - ▼▲ Intercom Pin 2
 - ▲▲ Intercom Pin 3

- Headphone Controls**
- ▼ Level/Level
 - ▲ Level/Balance

- Headphone Reverse**
- ▼ Normal
 - ▲ Reverse

- Headphone Minimum**
- ▼ -40 dB
 - ▲ Full Mute

- Main Button Mode**
- ▼ Normal
 - ▲ Talkback Forces Latch Off

- Relay Mode**
- ▼▼ Disabled
 - ▲▼ Follows Main Out
 - ▼▲ Follows Talkback 1
 - ▲▲ Follows Talkback 2

- Sidetone Mode***
- ▼ Disabled
 - ▲ Enabled

- System Mode***
- ▼ On-Air
 - ▲ Production

*Applies to units with serial numbers M230-01151 and later.

- Phantom Power (P48)**
- ▼ Off
 - ▲ On

- Headphone Right Channel Status**
- ▼ Enabled
 - ▲ Disabled

- Headphone Stereo/Mono**
- ▼ Stereo
 - ▲ Mono

Intercom Pin 2 is RTS™ TW Channel 1.
Intercom Pin 3 is RTS™ TW Channel 2
or Clear-Com® Channel 1.

**STUDIO
TECHNOLOGIES**

www.studio-tech.com

31265 Rev A

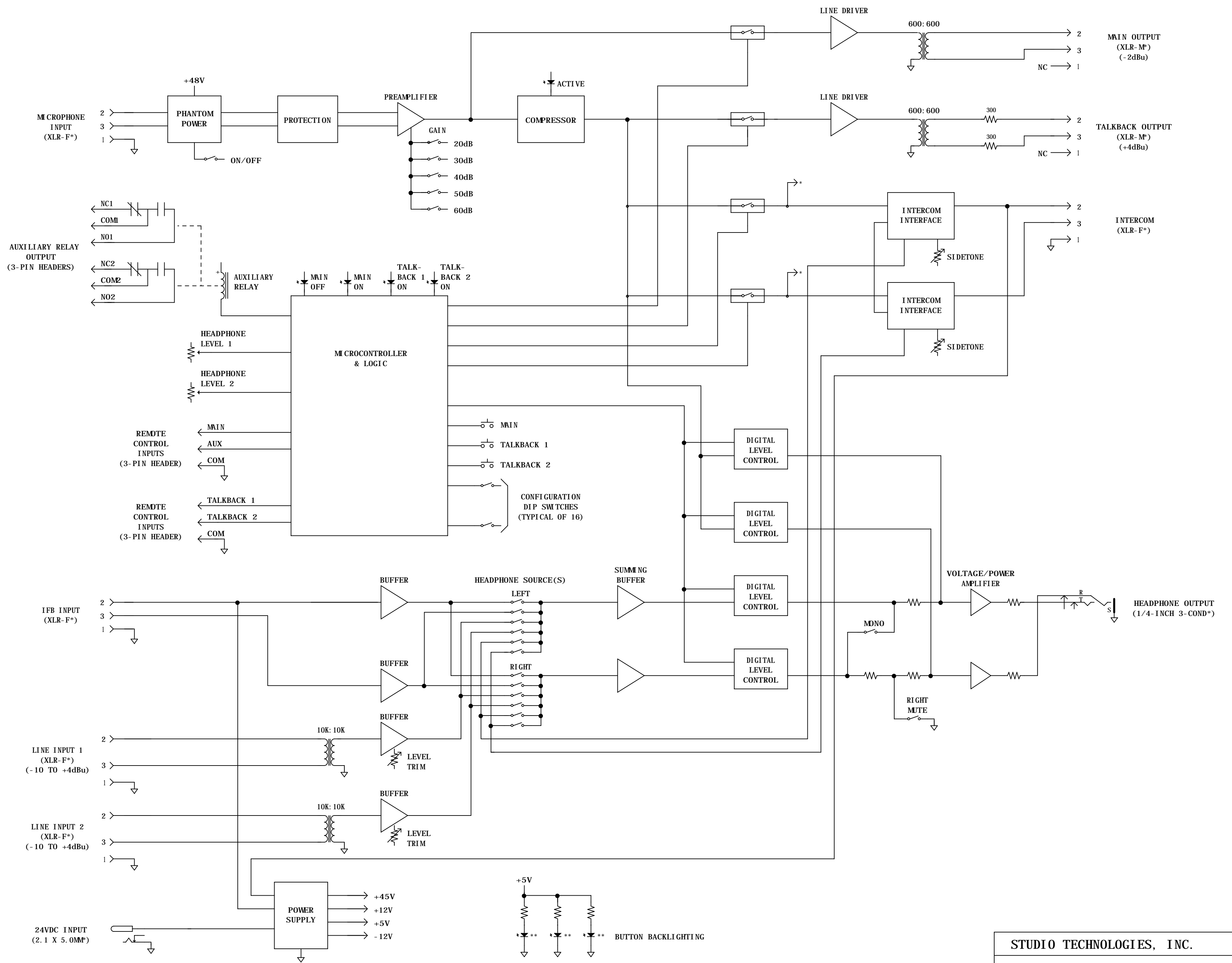

M230BD_D

STUDIO TECHNOLOGIES, INC.		
MODEL 230 ANNOUNCER'S CONSOLE BLOCK DIAGRAM		
DRAWING NO.	DATE	PAGE
31113	02/06/13	01 OF 01

FOR SERIAL NUMBER 01151 AND LATER

* ALSO HAS 3-PIN HEADER IN PARALLEL ON PRINTED CIRCUIT BOARD
 ** OPTIONAL - NOT FACTORY INSERTED

