

StudioComm

Model 55 Central Controller, Model 56 Control Console, and Related Components

User Guide

Issue 3, December 1996

This User Guide is applicable for serial numbers:

Model 55 M55-00151 and later

Model 56 M56-00151 and later

© 1996 by Studio Technologies, Inc., all rights reserved

5520 West Touhy Avenue
Skokie, Illinois 60077 U.S.A.
Telephone (847) 676-9177
Fax (847) 982-0747
www.studio-tech.com

Table of Contents

Foreword	
Introduction	7
What This User Guide Covers	7
System Overview	7
System Features	8
Installation	12
Configuration	17
Model 56 Configuration Chart—Main Functions	21
Model 56 Configuration Chart— Alternate Functions	22
Operation	23
Model 55 Central Controller	23
Model 56 Control Console	23
Talent Amplifiers	25
Troubleshooting	26
Technical Notes	28
Specifications	33
Appendix A	36
MIDI Messages	38
Block Diagrams	
Model 55 Central Controller	
Model 56 Control Console	
Model 35/Model 38 Talent Amplifiers	
Model 70 Interface	

This page intentionally left blank.

Foreword

I am pleased to present the StudioComm series of products. As both president and owner of Studio Technologies, I take a very personal approach when designing products. Getting older (40 as of this writing) has increased my appreciation of the more subtle things in life—be they a part of nature or the nuances contained in a well-designed piece of electronic equipment. Do the technical and operational aspects of a product work together to “feel” right? A Studio Technologies’ design is ready to go only when I am completely satisfied. My entire focus for the StudioComm series was to make a system that you’d really enjoy using, and one that would perform reliably for years. I hope you share my enthusiasm.

Many fine people worked toward making the StudioComm “happen.” Mitch Budniak (ace consulting engineer) designed many of the circuits. Jim Cunningham contributed to the analog design. Carrie Loving provided engineering support. Barbara Govednik coordinated the marketing communications aspects. Ben Kamen designed the automatic testing routines. Larry Leviton wrote the excellent micro-controller software. Al Lux designed the printed circuit boards. Jim McGuire designed the graphics. Fred Roeck performed the mechanical design. Joe Urbanczyk coordinated the safety testing and agency approvals.

Many thanks to Bob Tjarks, professional audio sales manager at Gand Music & Sound, Northfield, Illinois. Bob brought to my attention the need for a product to serve digital audio workstations. His product idea evolved into the StudioComm series. Additional thanks to Timothy Powell of Metro Mobile Recording, Glenview, Illinois, who provided his excellent ears when issues of sonic quality arose. His extensive field and studio experience was extremely helpful in keeping me on the audio “straight and narrow.”

Please contact me with your questions, comments, and suggestions. I can be reached by voice at (847) 676-9177, fax at (847) 982-0747, or via the Internet @ www.studio-tech.com.

Sincerely,

Gordon K. Kapes
President

This page intentionally left blank.

Introduction

The Model 55 Central Controller, along with the companion Model 56 Control Console, are members of the StudioComm family of products. The Models 55 and 56 are specifically designed to work in conjunction with digital audio workstations to provide a full set of monitoring and communications functions. Features include control room monitoring, meter output, an integrated headphone system, dubbing, and communications functions that include talk to phones and slate. All StudioComm functions perform to a level that rivals even the largest recording consoles. Many of the functions are user configurable, allowing unmatched flexibility.

What This User Guide Covers

This User Guide is designed to assist you when installing, configuring, and using the Model 55 Central Controller, Model 56 Control Console, Model 35 Talent Amplifier, Model 38 Talent Amplifier, and related components. A limited amount of troubleshooting and background technical information is also provided. Should you require detailed technical information please refer to the StudioComm Service Guide covering the Models 55, 56, 35, and 38. The Service Guide contains detailed service information, including schematic diagrams. The Service Guide is not shipped with each StudioComm system, but is available from the factory upon request. It is free of charge to purchasers of StudioComm equipment. Give us a call or send a fax if you need this highly exciting document!

System Overview

A complete StudioComm system consists of a rack-mounted central controller, a desktop control console, and one or more portable talent amplifier units. The Model 55 Central Controller and the Model 56 Control Console work together, interconnecting using a standard 5-pin MIDI-style cable.

Circuitry in the Model 55 routes any of four stereo inputs to the control room, meter, headphone, and dub outputs, with commands provided by the Model 56 Control Console. The Model 56 Control Console's built-in microphone lets you talk to the headphone output. It also allows you to talk to the dub output, or to the dub and headphone outputs using the slate function.

The Model 35 Talent Amplifier is a portable amplifier unit capable of driving one or two pairs of high-impedance stereo headphones. A single microphone-type cable links the Model 35 with the Model 55 Central Controller. The Central Controller provides power and left and right audio over just three wires.

The Model 38 Talent Amplifier takes the basics from the Model 35 and adds a unique stereo preamplifier section. This allows each Model 38 user to create an individual headphone mix, solving the classic problem of wanting "more me" in the phones! Like the Model 35, the Model 38 is linked to the Model 55 Central Controller by a single microphone-type cable.

System Features

Stereo Line Inputs

The Model 55 contains four stereo line-level inputs which are compatible with both balanced and unbalanced signals. Each input is independently software configurable for a nominal input level of -10dBV or $+4\text{dBu}$. This allows direct connection with virtually any audio source. Each input can also be configured to operate as a mono input. In this manner, a signal connected to the left input is routed to both the left and right outputs.

Control Room Monitoring

The control room section provides a stereo line-level output for driving a power amplifier associated with monitor loudspeakers. Four buttons are used to select

the input source to be monitored. Normally, only one of the four input sources is selected for monitoring. For special applications, the system can be configured to allow two input sources to be simultaneously monitored. The control room level is adjusted using a smooth-feeling rotary potentiometer. The Dim button allows the control room level to be temporarily reduced. The Mono button allows the sum (L+R) of the selected source to be sent as the control room output.

Meter Output

The meter output provides a stereo output that “follows” the source(s) selected for the control room. The signal is not affected by the control room level circuitry, but is “post-mono.” The meter output is intended to be connected to VU- or PPM-type meter

Model 55 Front Panel

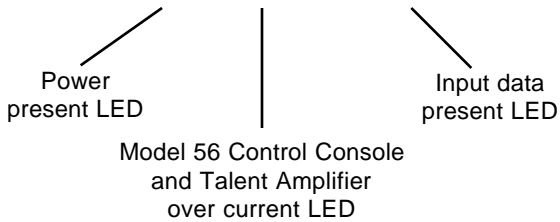
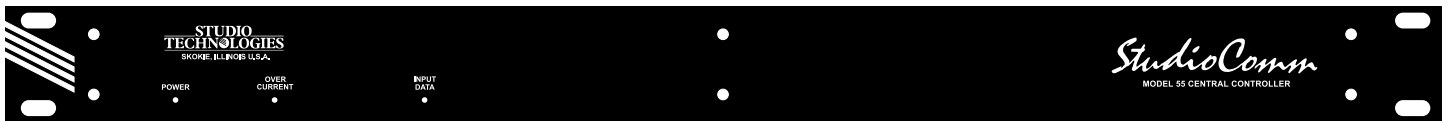

Model 55 Back Panel

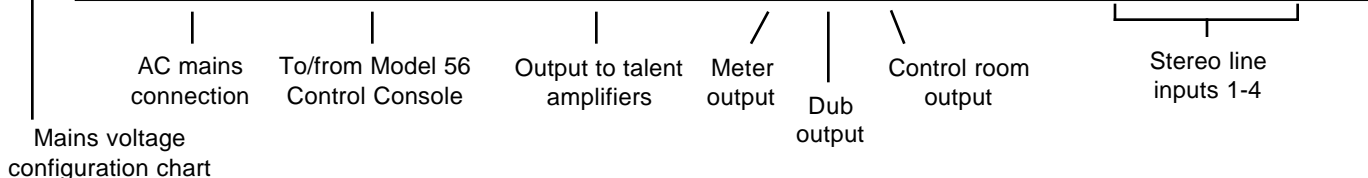
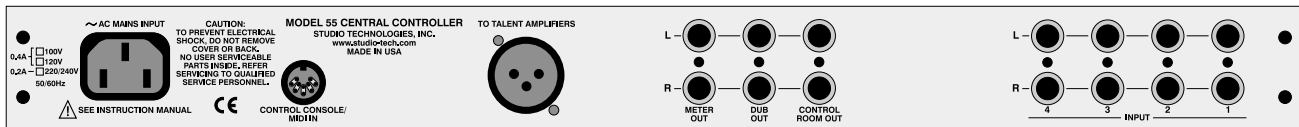

panels that contain series current-limiting resistors or input buffer amplifiers.

Dub Output

A stereo line-level output is provided as a dub (copy) output. Any of the four inputs can be assigned to the dub output. The slate function allows communications (voice) audio to be sent out the dub output.

Communications Functions

The Model 56 Control Console contains an internal microphone that is used in conjunction with the two communications functions. The talk to phones function either interrupts the phones source or adds (sums or mixes) to the phones source. The slate function interrupts the dub source and, if configured, the headphone source and connects communications audio. The audio level of each communications function is individually adjustable.

MIDI Control

All Model 55 Central Controller functions are controlled using system-exclusive MIDI messages. The Model 56 Control Console “speaks” this language, and in most applications a Model 56 will be utilized. In special applications the Model 55 Central Controller can be connected directly to a MIDI bus, allowing the creation of a fully automated recording or audio routing system. For more information on MIDI support, refer to Appendix A.

Configuration

The Model 56 Control Console can be configured to make the system meet a user’s exact operating environment. All configuration parameters, along with “power down” operation conditions, are stored in nonvolatile memory.

- Each of the four stereo line inputs can be independently set for -10dBV or $+4\text{dBu}$ operating levels.
- Each input can be set for either mono or stereo operation. In the mono mode a signal connected to the left input is sent to the left and right outputs.
- The dub output level can be set for a nominal -10dBV or $+4\text{dBu}$ output level.
- Unique to the system is the ability to configure the dim level to one of three values, allowing a 15, 20, or 25dB reduction when dim is active.
- Three functions can be set for push-to-latch operation if desired: talk to phones, slate, and control room mono.
- The auto dim off function, when configured, allows any change in the control room level potentiometer to automatically turn off an active dim state.
- The slate function can be configured to talk to the dub output, or talk to both the dub and headphone outputs.
- The talk to phones function can be set to interrupt the normal phones source or add (sums) to the phones source.
- The system can be configured to allow only one input source, or one or two input sources to be selected as the control room source(s).

Headphone Monitoring

The StudioComm system contains an integrated, full-featured headphone (cue) system. Up to four Model 35 or Model 38 Talent Amplifiers can be connected to the Model 55’s talent amplifier output. A single 3-conductor microphone-type cable carries power and stereo audio.

Model 56 Front Panel

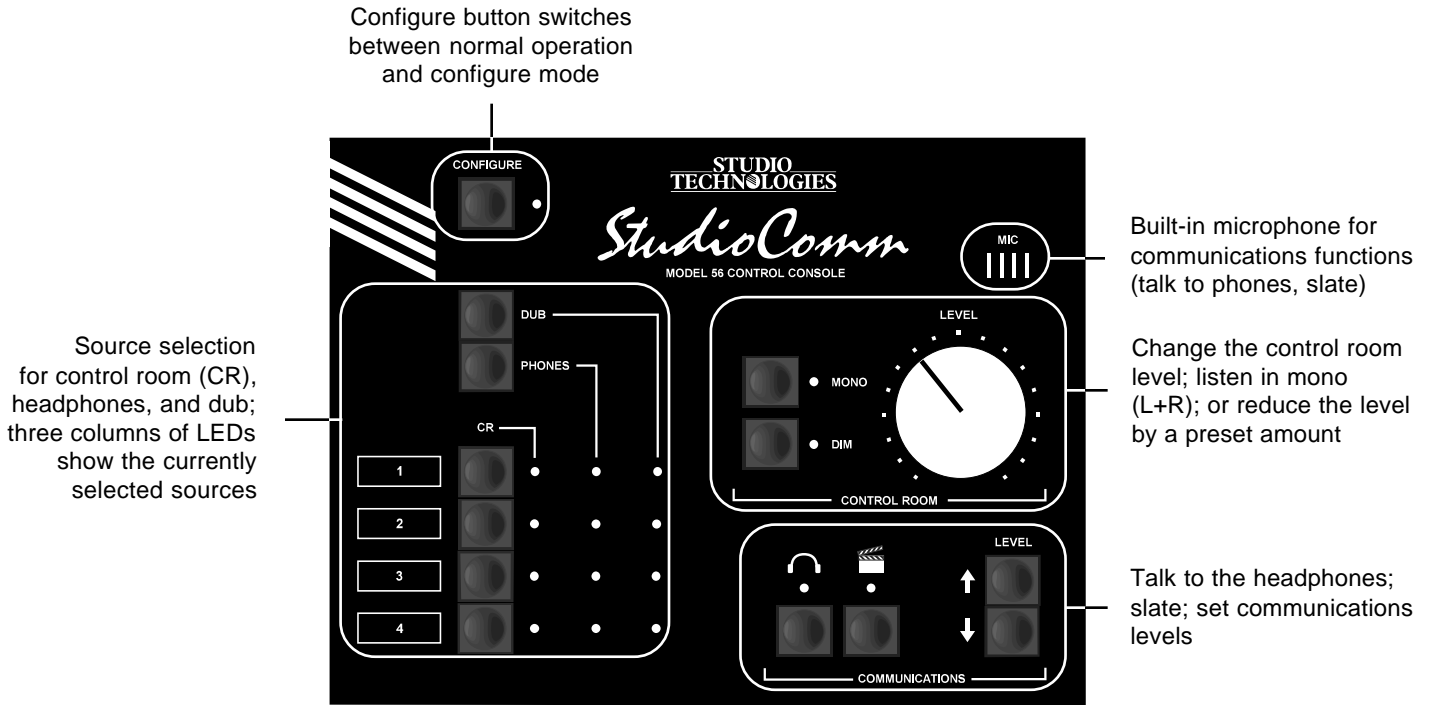

Model 56 Back Panel



Connection to the Model 55 Central Controller

Using the Model 56 Control Console, any of the four stereo inputs can be assigned to the talent amplifier output. The talk to phones and slate functions allow communications (voice) audio to be sent to the talent amps. The talent amplifier output is short circuit protected. Error conditions are displayed by the Over Current LED on the Model 55's front panel.

Each Model 35 and Model 38 Talent Amplifier can drive two sets of high-impedance headphones ($>150\Omega$). The audio output is loud, and very "clean." The units feature a built-in level control, a stereo/mono switch, and a power present LED.

The Model 38 Talent Amplifier takes the basics from the Model 35 and adds a unique stereo preamplifier section. This

Model 35 Front Panel

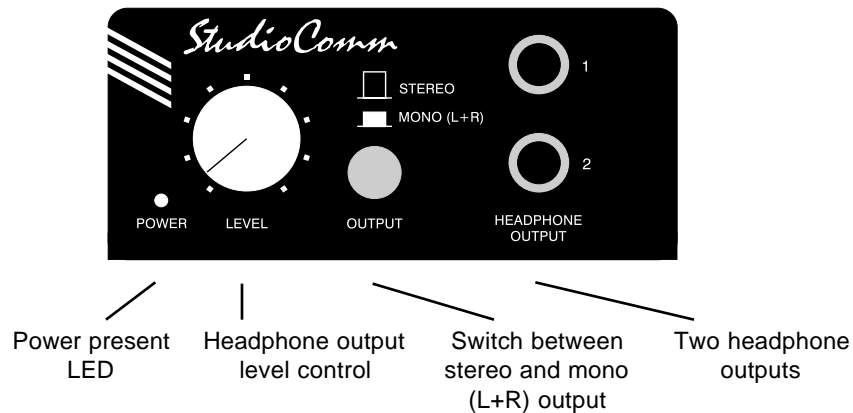

Model 35 Back Panel

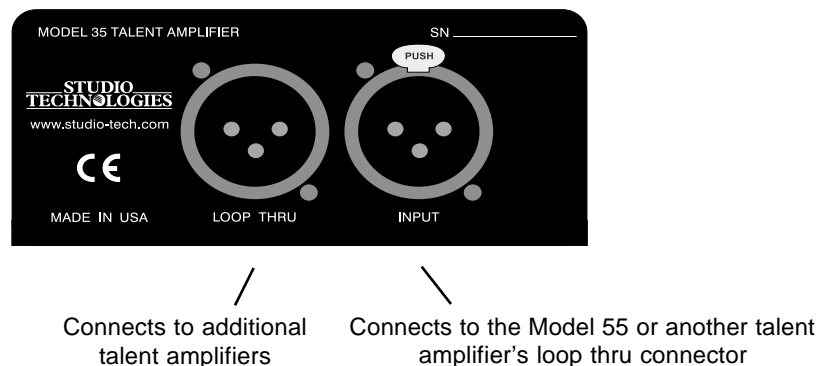

allows a musician's microphone or line-level signal to be "looped" through the Model 38, boosted by its preamp, and then combined with the stereo cue mix supplied by the Model 55. This provides each Model 38 with an individual headphone mix, solving the classic problem of wanting "more me" in the phones! Like the Model 35, the Model 38 is linked with a Model 55 Central Controller by a single cable.

Installation

In this section you will be installing the Model 55 Central Controller in an equipment rack. Audio input and output connections will be made using the Model 55's multitude of jacks. One or more Model 35 or Model 38 Talent Amplifiers may be connected. A location will be selected for

Model 38 Front Panel

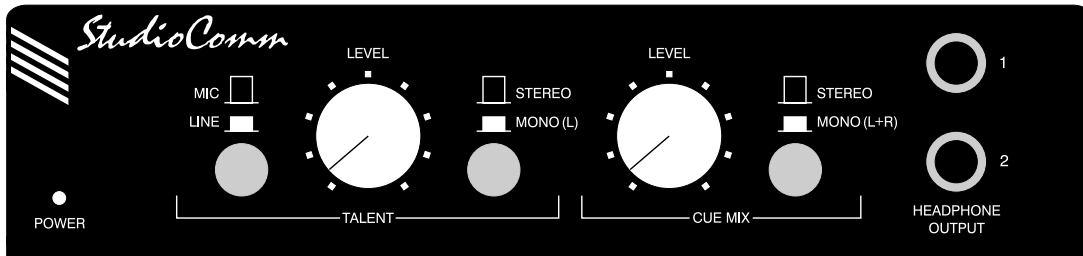

- Power present LED
- Mic/Line button switches the talent input between microphone and line level
- Talent level to phones
- Switch between stereo and mono (L only) for the talent input
- Cue mix level to phones
- Switch between stereo and mono (L+R) for the cue mix
- Two headphone outputs

Model 38 Back Panel

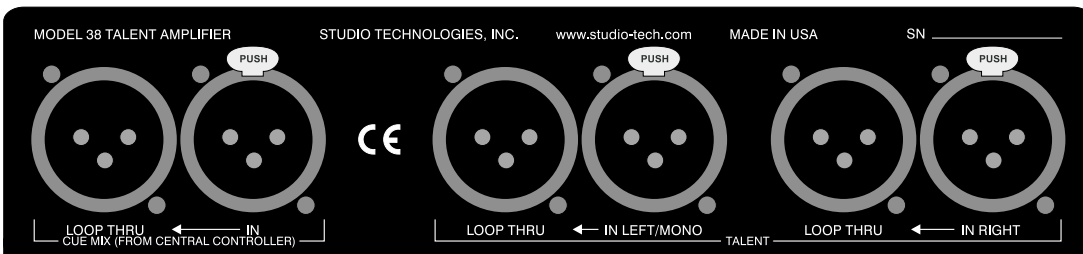

- Connects to additional talent amplifiers
- Connects to the Model 55 or another talent amplifier's loop thru connector
- Loop thru connectors parallel the talent inputs for routing to a digital audio workstation, effects device, microphone preamp, etc.
- Connects to talent sources such as keyboards or microphones

the Model 56 Control Console, and it will be connected to the Model 55. AC mains power will be connected to the Model 55.

System Components

The main StudioComm shipping carton contains a Model 55 Central Controller, Model 56 Control Console, 5-conductor MIDI-style cable, User Guide, and warranty card. Units destined for North America are shipped with an AC mains cord. Your dealer or distributor will provide an AC mains cord for non-North American destinations. Model 35 and Model 38 Talent Amplifiers, along with accessories, will be contained in separate cartons. Please check to ensure you have everything you need.

Mounting the Model 55

The Model 55 requires one space in a standard 19-inch (48.3cm) equipment rack. Select a location near where the Model 56 Control Console will be located. A cable is provided to connect the Model 55 to the Model 56. You can supply a longer cable, however 50 feet (15.3m) is the recommended maximum length. It is desirable to locate the Model 55 to allow easy access to both the front and the back panels. The back panel contains all of the input and output connectors, while the front panel contains several LED indicators. The Model 55 is secured to the equipment rack using two mounting screws per side.

Audio Inputs and Outputs

The Model 55's line-level audio input and output connections are made using ¼-inch 3-conductor phone jacks. Don't be concerned about our use of phone jacks as part of a "professional" product. The jacks

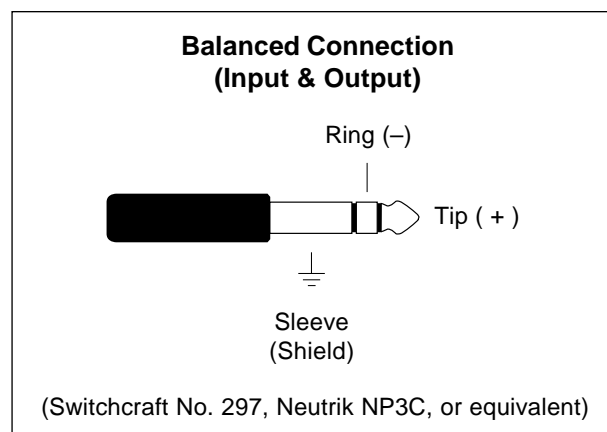

used are manufactured by Neutrik, and feature gold-plated contacts for high reliability.

Caution: For reliable audio interconnection, the plugs you use must comply with industry standard RS-453. Switchcraft No. 297, Neutrik NP3C, or equivalent will work correctly. Refer to the Technical Notes section for details.

Stereo Line Inputs

The Model 55 provides four stereo line-level inputs. Each input is electronically balanced, and can be configured for compatibility with -10dBV or $+4\text{dBu}$ signal levels. The Model 56 Control Console gives you push-button control, so you can easily change input sensitivities at any time (refer to the Configuration section under Input Sensitivity). Monaural sources should be connected to the left (L) input and configured for mono operation (refer to the Configuration section under Stereo/Mono Input).

Prepare the mating connectors (plugs) so that tip is signal high (+ or hot), ring is low (– or cold), and sleeve is shield. With an unbalanced source connect the tip to

high (+ or hot), and both the ring and sleeve to shield. If connecting to an unbalanced source in this manner results in hum or noise, connect tip to high (+ or hot) and ring to shield; leave the sleeve unterminated.

Control Room Output

The Model 55 contains a stereo line-level output for connection to an audio power amplifier. This audio amplifier serves a pair of loudspeakers that are located in the control room. (Of course the control room output can be connected to loudspeakers that contain integral power amplifiers, such as the products from Genelec.)

The output is electronically balanced and capable of driving loads of 600 ohms or greater. In most situations best performance will be obtained if the audio amplifier's input sensitivity is set to near maximum. Refer to the Technical Notes section for details on setting amplifier sensitivity.

The control room output utilizes two ¼-inch 3-conductor phone jacks for interconnection. Prepare the mating connectors (plugs) so that tip is signal high (+ or hot), ring is low (– or cold), and sleeve is shield. To connect to an unbalanced load connect the tip to high (+ or hot), and both the ring and sleeve to shield.

Meter Output

The meter output is intended to be connected to a VU- or PPM-type meter panel that contains input buffer circuitry or series current-limiting resistors. Each output is unbalanced, has a nominal level of +4dBu, and is capable of driving loads of 2k ohms and greater.

The meter output utilizes two ¼-inch 3-conductor phone jacks for interconnection. Prepare the mating connectors (plugs) so that tip is signal high (+ or hot), sleeve is low (– or cold); ring is not connected.

Dub Output

The Model 55 contains a stereo line-level output which is intended for connection to a variety of analog audio devices. The dub output is electronically balanced and capable of driving 600 ohm loads or greater. With the input impedance of most audio devices at 10k ohms or greater, the dub output can easily drive 10 or more devices simultaneously.

The dub output can be configured for a nominal level of –10dBV or +4dBu, so you can connect to all line-level inputs with no hassle (refer to the Configuration section under Dub Output Level).

The dub output utilizes two ¼-inch 3-conductor phone jacks for interconnection. Prepare the mating connectors (plugs) so that tip is signal high (+ or hot), ring is low (– or cold), and sleeve is shield. To connect to an unbalanced load connect the tip to high (+ or hot), and both the ring and sleeve to shield.

Talent Amplifier Output

Up to four Model 35 or Model 38 Talent Amplifiers can be connected in any combination to the Model 55's talent amplifier output. The output connector is a 3-pin male XLR-type. For best performance, use low-capacitance shielded microphone-type cable to distribute the talent amplifier signal. If you have a choice, select cables with the heaviest wire gauge commonly available. This will reduce voltage drop

when using long cable runs. Refer to the Technical Notes section for additional information.

The simplest installation would use a microphone cable to connect the Model 55 to the first talent amplifier; the loop through connector on that talent amp sending the signal on to the next talent amp.

For convenience, you may want to wire your facility to allow easy access to the talent amplifier signal at all locations where talent amplifiers might be used. The talent amplifiers connect to the Model 55 in parallel, so the connectors on the distribution panels or mult boxes must be wired in parallel.

Warning: Do not connect the Model 55's talent amplifier output to anything but Studio Technologies' talent amplifiers. Some audio equipment may be damaged by the +23Vdc contained on pin 2 of the talent amplifier output connector.

Several mounting options are available for the Model 35 and 38 Talent Amplifiers. For details refer to Mounting Options in this section.

In special cases you may need to obtain a stereo, balanced line level output signal from the Model 55 talent amplifier output. The Model 70 Interface is available for this purpose. For details refer to the end of this section.

Locating the Model 56 Control Console

The Model 56 was designed for desktop use, however provision has also been made for microphone-stand mounting. For details refer to Mounting Options in this section.

Connecting the Model 55 to the Model 56

A standard 5-conductor MIDI-style cable is used to connect the Model 55 to the Model 56; a cable is included with your system. Just connect the cable between the female 5-pin DIN-type connectors on the back of the Model 55 and 56, and you're done.

Note: If you require a longer cable, be certain to buy a MIDI cable that has all 5 pins wired. If they aren't all connected, the Model 56 will not operate. This is because the Model 55 powers the Model 56 with the pins that aren't used for MIDI data.

For best performance, the cable that connects the Model 55 with the Model 56 should be limited to 50 feet (15.3m). Should you need to exceed this length, refer to the Technical Notes section of this guide for details on the cable requirements.

For more information on MIDI, and using controllers other than the Model 56, please refer to Appendix A.

AC Mains Power

The Model 55 is internally configured to operate from either 100, 120, or 220/240V, 50/60Hz. In most cases, units shipped to North America are factory selected for 120V operation. Units bound for Japan are selected for 100V, while our friends "down under" and in Europe receive units set for 220/240V. Before connecting the Model 55 to mains power, check that it is configured to match the local mains voltage. Look on the back panel, adjacent to the power entry connector, for the configured voltage(s). Note that an incorrect configuration could seriously damage the unit. Should it be necessary to change the

unit's operating voltage it must be performed only at the factory or by an authorized service technician.

The Model 55 uses an IEC standard connector to mate with the AC mains cord. The wire colors in the AC mains cord should conform to the internationally recognized CEE color code and must be wired accordingly:

<u>Connection</u>	<u>Wire Color</u>
Neutral (N)	Light Blue
Line (L)	Brown
Protective Earth (E)	Green/Yellow

Safety Warning: The Model 55 does not contain an AC mains disconnect switch. As such the mains cord plug serves as the disconnection device. Safety consideration requires that the plug and associated outlet be easily accessible to allow rapid disconnection of mains power should it prove necessary.

As soon as mains power is applied, the Model 55's power present LED will light. The Model 56 will go through its power-up sequence lighting each LED in a rapid sequence. The power present LEDs on the talent amplifiers will also light.

The Over Current LED located on the front panel of the Model 55 should not be lit. If it is flashing, immediately refer to the Troubleshooting section of this guide. If everything appears to be functioning properly you are now ready to configure the system.

Model 35 Stand Mounting

Included with each Model 35 Talent Amplifier is a nifty mounting adapter that allows the unit to be conveniently attached to a

microphone stand. Please refer to the Installation Guide provided in the Model 35's shipping carton for details.

Model 38 and Model 56 Mounting Options

The Model 38 Talent Amplifier and the Model 56 Control Console include provisions for mounting to microphone stands, equipment consoles, etc. To avoid "reinventing the wheel," our products are compatible with the 25 Series components from OmniMount Systems, Tempe, Arizona U.S.A. (602) 829-8000, a supplier of finely engineered mounting systems. This firm makes many versions of the 25 Series; one of which should fit your needs. If you desire microphone stand mounting the following components would be appropriate: 25RST-25H Straight Tube Reverse Mount with Quick Release, along with a 25MA Microphone Stand Adapter. (If quick adjustment is not required the 25RST Straight Tube Reverse Mount can be used in place of the first item.) When connecting to metric-thread stands please contact OmniMount for the correct part numbers.

The bottom surface of the Model 38 Talent Amplifier contains two threaded inserts that will accept English-standard ¼-20 screws. Using two, 5/8-inch long, round-head machine screws, the 25 Series clamp assembly can be directly attached. The cover of the Model 38 does not have to be removed.

The design of the Model 56 did not allow the inclusion of threaded inserts, so holes of adequate size to allow ¼-20 round head machine screws are provided. It is intended that screws of 5/8-inch length, along with lock washers and machine nuts, will securely attach a 25 Series mounting

clamp assembly. The cover of the Model 56 will have to be removed to gain access to mounting holes. Be careful when selecting the mounting screws—exceeding the recommended $\frac{5}{8}$ -inch length will cause the mounting screws to damage the Model 56's internal components.

Model 70 Interface

In most cases Model 35 and/or Model 38 Talents Amplifiers will be used to drive headphones associated with a StudioComm installation. In special cases a line level signal may be required to interface the Model 55 Central Controller's talent amplifier output with other audio equipment. An example would be to use the Model 55 with an existing headphone system. The Model 70 Interface is used to convert the talent amplifier signal to a stereo, balanced line level signal.

Installation is very simple. Connect the Model 70 to the Model 55 Central Controller's talent amplifier output using a standard 3-conductor microphone-type cable. For best performance, use low-capacitance shielded cable.

The Model 70 provides independent left and right balanced outputs. Pin 1 is shield, pin 2 is signal positive (+ or hot), and pin 3 is signal negative (– or cold). The electronically balanced outputs have a nominal signal level of +4dBu and are capable of driving loads of 600 ohms or greater.

The Model 70 can be used by itself, or in conjunction with up to four Model 35 or Model 38 Talent Amplifiers. The loop through connector on the Model 70 can be used to connect to a Model 35 or 38 Talent Amplifier.

Model 70 Front Panel

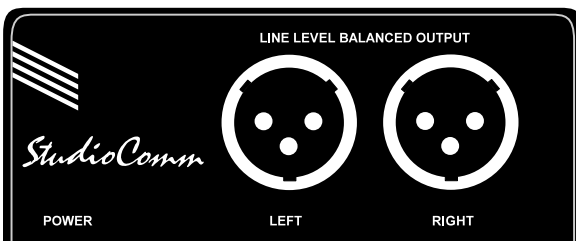

Model 70 Back Panel

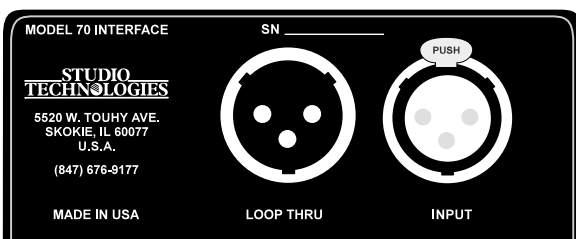

Configuration

Many StudioComm functions can be configured to meet the exact needs of your installation. Here's an overview of what you can configure:

- –10dBV or +4dBu sensitivity for each input
- Stereo or mono for each input
- –10dBV or +4dBu level for the dub output
- Dim level
- Momentary or latching operation for mono, talk to phones, and slate buttons
- Auto dim off function
- Slate feed to phones

- Talk to phones interrupts or adds to phones source
- Allow simultaneous selection of two control room sources

The Configure button allows the Model 56 to go into the configure mode. While in the configure mode, all the Model 56's buttons and LEDs are associated with configure functions. Refer to the Model 56 Configuration Chart later in this section.

To enter the configure mode, press and hold the Configure button for two seconds. While in the configure mode, all audio outputs switch off and the orange LED beside the Configure button will flash. As you make changes, the Model 56 keeps track of the new settings and updates the system when you exit the configure mode. You must exit the configure mode before any changes take effect.

Input Sensitivity

The CR column of four red LEDs shows you whether an input is set to be compatible with -10dBV or $+4\text{dBu}$ signal levels. When a red LED in the CR column is off, it means the input is set to -10dBV . When lit, the corresponding input is set to $+4\text{dBu}$. Just press the CR buttons to toggle inputs 1 through 4 between -10dBV and $+4\text{dBu}$.

Stereo/Mono Input

The Phones column of green LEDs indicates whether an input is configured for mono or stereo operation. When a green LED in this column is off, the input is set for stereo; the LED on means the corresponding input is set for mono. In mono mode, the left input is sent out both the left and right outputs. To toggle a channel between stereo and mono, press and hold the Phones button and press the CR

buttons that correspond to inputs 1 through 4. After you leave the configure mode, inputs configured for a mono source will flash during normal operation.

Dub Output Level

The Dub column of orange LEDs will help you configure two options: dub output level and dim level. The orange LED in the first row (number 1 at the top) tells you whether the dub output is set to -10dBV or $+4\text{dBu}$. When the LED is off, the dub output is set to -10dBV ; when it's on, the dub output is configured for $+4\text{dBu}$.

Dim Level

The dim function is used to reduce the control room output level a preset amount whenever you press the Dim button. You can take a quick phone call without using the level control to change the control room level. Also, any time you press the talk to phones or slate buttons the dim function is activated.

In the configure mode, LEDs 2 through 4 in the Dub column indicate the selected dim level. Dim can only have a single setting, so only one of the orange LEDs is on at a time.

<u>Row Number</u>	<u>Dim Value (dB)</u>
2	25
3	20
4	15

When the orange LED is on in row two, dim is down 25dB. Dim is down 20dB in row three, and 15dB in row four. To change the dim level, hold down the Dub button while pressing the CR button of your choice.

Mono Function

The Mono function allows the control room output to be placed in the mono (L+R) mode. When you're in configure mode, the red LED labeled Mono tells you whether the Mono button works as a momentary or latching button. When the button is set to momentary, the LED will be off and mono mode will only be active while you press and hold the Mono button. When the LED is on, the button is set to latch. With this setting, you can press the Mono button once and it will remain in mono mode until you press it again.

Auto Dim Off

The auto dim off function is unique to StudioComm products, making the dim function respond to real world operating conditions. When enabled the function automatically turns the dim function off if a change is made to the control room level potentiometer while the unit is already in dim mode. This prevents a heart-stopping blast of audio when an engineer presses the dim button to turn dim on, but actually turns it off because the unit was already in the dim mode. While it's hard to explain unless you've used a console and experienced this in person, trust us, this situation does happen! Auto dim off is a wonderful "real-world" function and in most cases should be configured.

In the configure mode the Dim LED tells you if auto dim off is enabled. When the dim LED is off, the auto dim off function is off; when the Dim LED is lit, the auto dim off function is on.

Communications Functions

There are two Communications buttons at the bottom center of the Model 56. Moving from left to right, the buttons are talk to

headphones and slate. During configuration, LEDs above the Communications buttons tell you whether the buttons will latch when you press them. When an LED is off, the button below it won't latch. You would have to press and hold the button to activate the function. When an LED is on, it indicates that the button will latch. Pressing the button will activate the function until it's pressed again.

Alternate Configure Functions

To allow additional functions to be configured, an alternate configure mode is utilized. By pressing and holding the Level Up button the alternate functions are accessed. This is like the ALT key on your personal-computer keyboard.

Slate to Phones

When you press the slate button, the Model 56's microphone is fed to the dub output. This is how you can record your own voice for marking takes. But there are times when it's convenient to have the slate provided in the headphone output as well.

While holding Level Up, the Phones LED is used to display whether the slate will go to the phones. When the LED is off, slate goes to the dub output only; when the LED is on, slate goes to both the dub and headphone outputs. While holding Level Up, press the button below the LED to toggle the setting.

Talk to Phones Interrupt or Add

The talk to phones function can be configured to either interrupt the source selected for phones audio and connect communications audio, or to have the communications audio added (summed or mixed) with the phones audio.

While holding Level Up, the slate LED is used to display whether talk to phones will interrupt the phones source, or add to the phones source. When the LED is off, the selected phones source will be interrupted and the communications audio source will be connected; when the LED is on the communications audio source will be added (mixed) to the phones audio source. While holding Level Up, press the button below the LED to toggle the setting.

Allow Two Simultaneous Control Room Sources

A feature has been added that allows any two of the four input channels to be simultaneously selected for monitoring over the control room output. This was added for applications where multiple “rough” or “scratch” audio signals need to be monitored at the same time. This feature can be enabled or disabled using the configuration procedure on the Model 56 Control Console.

Reset Factory Defaults

Provision has been made to allow you to return all configurable parameters to the factory default values. With the Model 56 in the configure mode, press and hold both the Dub and Phones buttons. After two seconds the factory defaults will be stored in memory, the configure mode will automatically end, and the Model 56 will return to normal operation.

Model 56 Configuration Chart—Main Functions

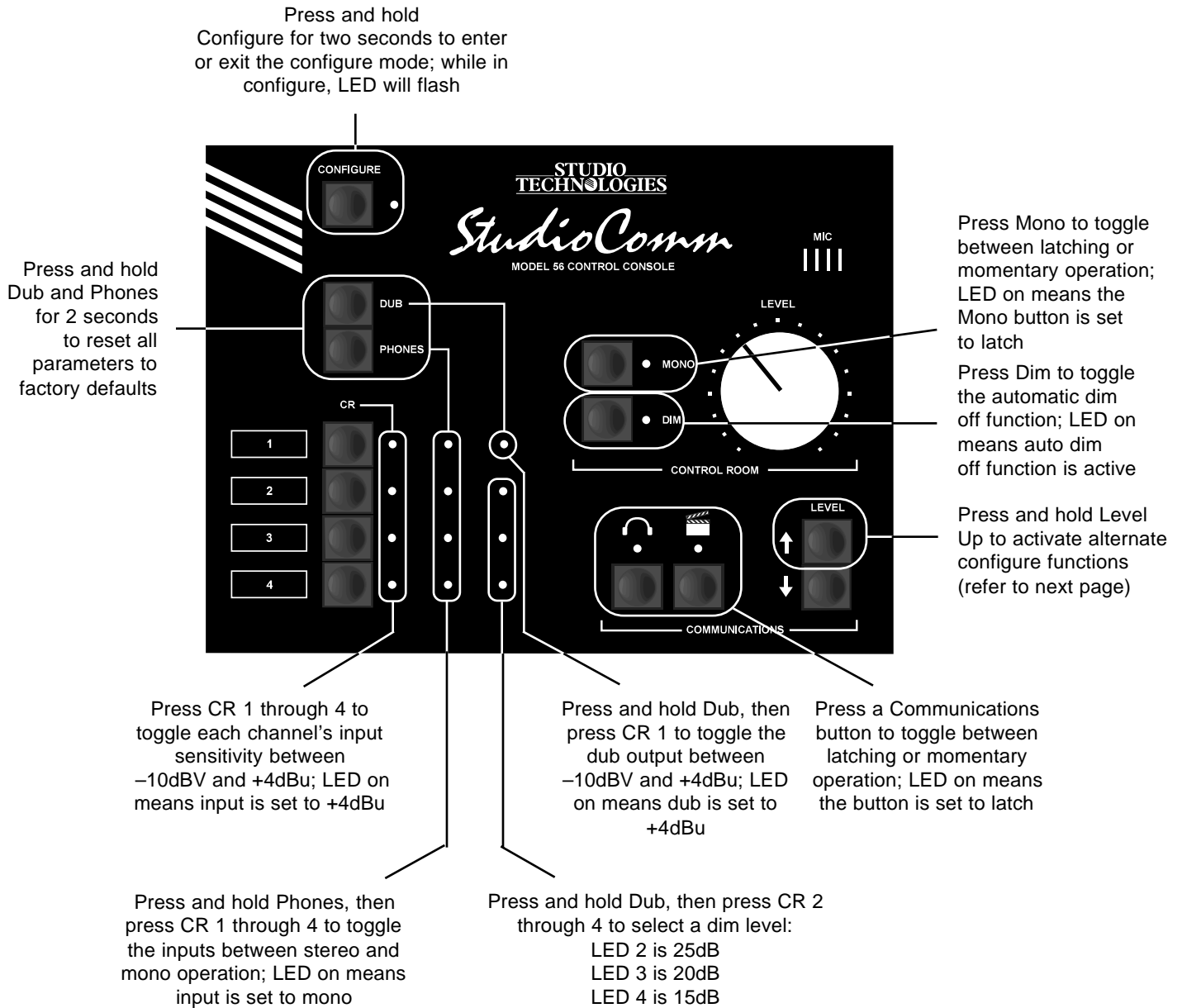

Model 56 Configuration Chart—Alternate Functions

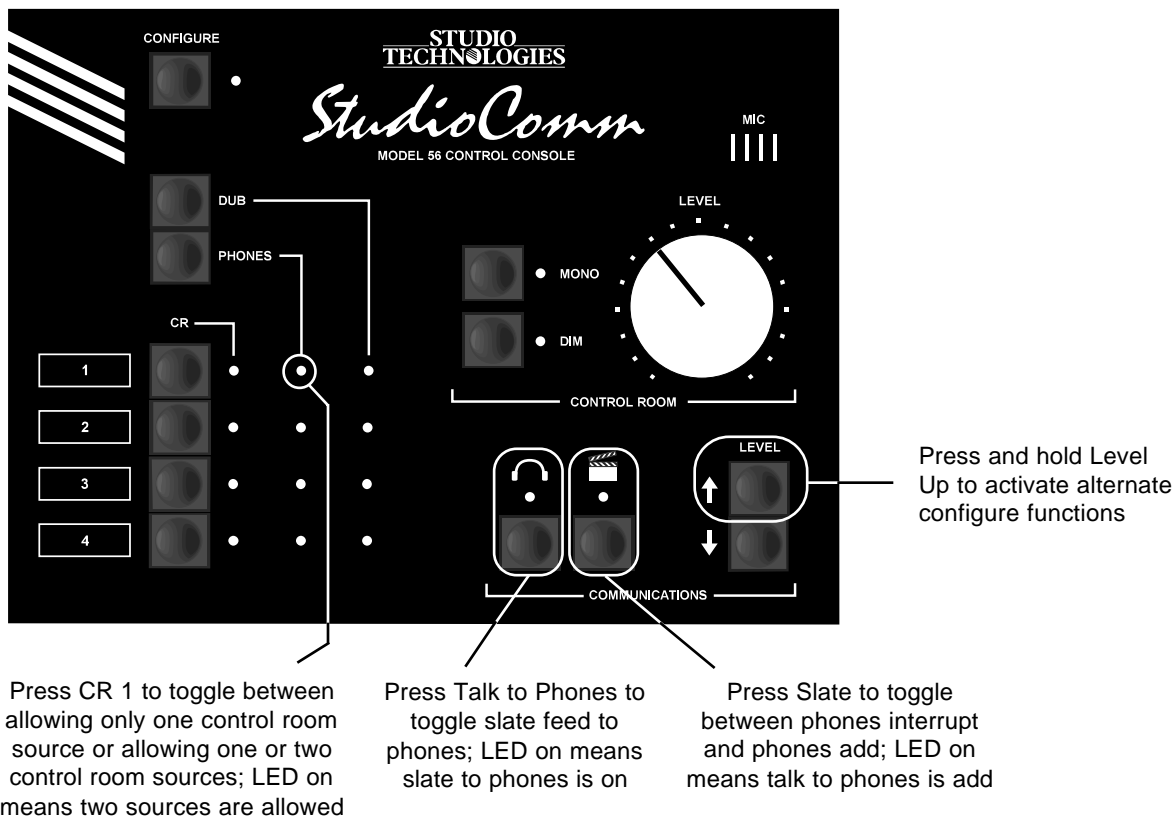

Operation

Now that you've installed and configured the system, you're ready to go. You should find operation very easy.

Model 55 Central Controller

The Model 55 front panel contains three LEDs. The power present LED should be lit whenever AC mains power is connected. During normal operation the Over Current LED will not be lit. It will flash only if there is a problem interfacing with the Model 56 Control Console or the talent amplifiers that you have connected. Refer to Troubleshooting section if the Over Current LED lights.

The Input Data LED will light whenever a message is received. Refer to the Troubleshooting section if the LED does not flash in response to a message from the Model 56 Control Console.

Model 56 Control Console

All StudioComm functions are controlled using the Model 56 Control Console. To make things easy, we've divided the StudioComm functions into three main groups: input-output selection, control room output, and communications functions.

Control Room/Meter Source Selection

To select an input for monitoring in the control room, press one of the four CR buttons. The corresponding LED in the CR column will light to let you know which input is selected. If the input is set for mono the LED will continually flash on and off as a warning. The same source will be connected to the meter output.

The system may have been configured to allow two control room sources to be selected simultaneously. If so, select the first source by pressing and holding one of the four CR buttons. Then, while keeping the first button pressed, select the second source by pressing one of the three other CR buttons. The two sources will be added (summed or mixed) together: L+L, R+R.

Headphone Source Selection

To select an input source for the headphone output, press and hold the Phones button and press one of the four CR buttons. In the Phones column, the LED for the input you select will light. If the input is set for mono the LED will continually flash on and off as a warning.

A special function allows you to select no input to be sent to the headphones. This ensures a quiet feed to the phones, but still allows the talk to phones function to be used. To select no input, simply press and hold the Phones button, then press both Communications Level buttons at the same time. The Level buttons are located to the right of the two Communications buttons. All LEDs in the Phones column will be off when no input is selected. To again select one of the four inputs, press and hold the Phones button, then press one of the four CR buttons.

Dub Source Selection

To select an input source for the dub output, press and hold the Dub button and press one of the four CR buttons. The appropriate LED in the Dub column will light. If the input is set for mono the LED will continually flash on and off as a warning. You can select no input just as you did

for the headphones. Press and hold the Dub button, then press both Level buttons at the same time.

Control Room Output

Associated with the control room output are two buttons and one level control. In addition, the Communications Level buttons are used. Use the Control Room Level knob to set the control room output level. There is no on/off switch. Just select an input and turn the knob to the level you want.

The Dim button lets you lower the control room level by a fixed amount. The amount of attenuation depends on the dim level set in the configure mode (refer to the Configuration section for help). The Dim button is always set to latch the function on or off.

If the auto dim off function is enabled, whenever dim is on and the control room level is changed, dim will automatically return to the off state. Note that the auto dim off function is not active whenever dim is on due to one of the communications functions being active.

The Mono button lets you send L+R to both the left and right control room outputs. The Mono button can be configured for momentary or latching operation.

For diagnostic purposes, the control room left-only or right-only mode can be activated. To enter the mode you use the Communications Level buttons. Press and hold both Level buttons for two seconds. The control room will switch from stereo operation to the left-channel-only mode. Press and hold the Level buttons again, and the control room switches to right channel only. Press and hold the Level

buttons a third time and the control room switches back to stereo operation. The Level buttons continue to cycle through left, right, and stereo monitoring as you press them.

The Mono LED indicates when you are in left-only or right-only modes. During left-only operation the LED will flash once; in right-only operation the LED will flash twice.

Note that the mono function is disabled during single-channel operation. If mono is active when entering the single-channel mode, the system will terminate the mono mode.

Communications Functions

Four buttons are associated with the communications functions. The two main buttons are called talk to phones and slate. They have symbols that represent (from left to right) a pair of headphones and a slate board (or "clapper"). Pressing each button activates the Model 56's built-in microphone and sends its audio to the appropriate output(s). Press the button under the headphone symbol to talk to the headphones; press the button under the clapper to slate. Remember that during a slate, microphone audio goes to the dub output or, depending on the configuration, to the dub and phones output. When you press one of the communications buttons, the LED above it will come on to tell you the function is active. Note that only one communications function can be active at a time.

When you press the communication buttons, various things happen depending on the Model 56's configuration. Either of these buttons may be configured to stay on (latch) when you press them. Also, if

the headphones are configured to receive slate audio, both the phones and slate LEDs will light when you press slate. The communications level to the headphones will be determined by the slate level setting (not the talk to phones level).

The talk to phones function is configured to interrupt or to add to the selected headphone source. If interrupt is selected, activating talk to phones disconnects the selected headphone source and connects communications audio. If add is selected, activating talk to phones leaves the headphone source connected and adds (sums or mixes) the communications audio.

You can independently set the output level for the two communications functions. To set the communications levels, press and hold either the talk to phones or slate button and press the Communications Level buttons. (If the talk to phones or slate buttons are set to latch, you won't have to hold them.) The LEDs above the buttons will flash each time the level is increased or decreased until you reach the top or bottom of the range. At this point, if you continue to press the same Level button, the LED won't flash, indicating you're at the top or bottom of the eight-step level range.

Headphone Level

The headphone output level is controlled only at the Model 35 and Model 38 Talent Amplifiers. There is no headphone level adjustment using the Model 56.

Configure Mode

Refer to the Configuration section for an understanding of how to use the Configure button.

Talent Amplifiers

Warning: protect your ears! The StudioComm talent amplifiers are capable of driving headphones to extremely high sound pressure levels. Hearing experts advise against continuous extended play, especially at high levels.

Model 35 Talent Amplifier

The power present LED should be lit whenever the Model 35 is connected to an operating Model 55. The Model 35 has a Level control and a Stereo/Mono button. You can plug in one or two pairs of headphones with a total impedance of 75 ohms or greater. Turn the knob to the output level you want and select stereo or mono by pressing the button. Both headphone outputs are controlled by the one level control. The Mono button sends L+R to both the left and right output.

Model 38 Talent Amplifier

The Model 38 has the unique ability to provide a personalized headphone mix for the in-studio talent. The performer's audio can be connected to the talent inputs and passively looped through to the control room. This lets performers increase their level in the headphone mix without an engineer getting involved. The Model 38's circuitry was carefully designed to not interfere with the talent audio as it passes through.

The Model 38 has all the functions of the Model 35, plus it provides personal mix controls. The power present LED should be lit whenever the Model 38 is connected to an operating Model 55. You can plug in one or two pairs of headphones with a total impedance of 75 ohms or greater.

The Cue Mix Level control sets the headphone output level for the signal coming from the Model 55. The Cue Mix Stereo/Mono button switches both headphone outputs between a stereo and mono (L+R) feed of the cue mix.

The Model 38 allows connection of a control Stereo or Mono talent signal at microphone or line level. If your talent source is stereo, connect it to the In Left/Mono and In Right connectors and set the Talent Stereo/Mono button for stereo operation. With a mono source, use only the In Left/Mono connector and set the Stereo/Mono button for mono operation. This will feed the mono talent source to both left and right headphone channels. Connect loop through cables as needed for feeds to the control room.

The Talent Mic/Line button is used to select an input sensitivity level for the talent source. When you connect a microphone or direct box, select Mic. When keyboards or other preamplified sources are connected, select Line. The expected signal level in the Mic position is -40 to -60dBu. In the Line position it's -10 to +10dBu. If you are unsure of your signal level, start with input sensitivity set for Line. If the output level is not sufficient, turn down the level control, switch to Mic, then listen as again you raise the level control.

The Talent Level control works just like you would guess: turn it up for more talent signal in the headphone mix, and turn it down for less. The Talent and Cue Mix level controls work like a mixer for the headphone outputs, so you can have any level you want of either source in the headphone mix.

Troubleshooting

If you're having problems getting the StudioComm system up and running, this section can help. If you haven't read the other sections of this guide, you should do so before proceeding.

If the Model 56 Doesn't Work At All

Your StudioComm system was supplied with a 5-conductor DIN-type cable that is used to connect the Model 56 Control Console to the Model 55 Central Controller. This cable has an important characteristic; it implements all five conductors. This means that all five pins on each plug connect to each other using a length of 5-conductor cable. If you choose to use your own cable it's easy to get in trouble; many MIDI cables only have three conductors! You **must** use a 5-conductor MIDI-style cable or the Model 56 will not power up and function. Five conductor MIDI cables are not hard to find, but you must ask for them and ensure that you get what you asked for. **Be warned!**

Over Current LED

During normal operation the Over Current LED, located on the front panel of the Model 55, should not light. It will light, flashing on and off, in response to problems with the Model 56 Control Console and/or the Talent Amplifier output.

The Over Current LED will light if the power source that supplies the Model 56 Control Console is loaded to exceed its maximum output current. The most common reason for an over current condition would be a shorted 5-conductor MIDI-style interconnecting cable. A major fault in the Model 56 would also cause the LED to light.

The Over Current LED will also light if the talent amplifier output is loaded to exceed its maximum output current. The most common reason for an over current condition would be a shorted interconnecting cable. Also, connecting more than the specified maximum of four Model 35 or Model 38 Talent Amplifiers can also cause the LED to light. Possible, but not likely, would be a fault condition in a Model 35 or Model 38.

If the Over Current LED does light, troubleshooting should prove quite simple. Begin by disconnecting the cables that are plugged into the Control Console/MIDI In and the talent amplifier output connectors. Perform the disconnection directly on the Model 55's back panel. The LED should stop lighting. Now reconnect to Control Console/MIDI In. If the LED again lights, follow this paragraph. If the LED does not light, skip to the next paragraph. Check the interconnecting cable that links the Model 55 with the Model 56 Control Console. You need to determine where the short circuit condition is located. The Model 55 will not be damaged if the Over Current LED is lighting so you should use it to help you locate the fault. In just a few minutes you should be able to isolate exactly if the cable or the Model 56 is causing the problem. Replace the cable if it proves to be bad—remember you'll need a MIDI-style cable with all five conductors connected. If the Model 56 appears to be at fault, it will need to be returned to the factory for repair.

If the LED did not light when you reconnected to Control Console/MIDI In, reconnect to the talent amplifier output. The LED should now light, identifying that the problem is with the talent amplifiers or associated cabling. In most cases you will find

that a cable is at fault. If a talent amplifier is found to be at fault, it will need to be returned to the factory for repair.

Input Data LED

The Input Data LED lights only when data is received that is valid for the Model 55. The Model 55 uses MIDI system-exclusive messages to perform all operations. When the Model 56 Control Console is connected to the Model 55, the LED will light any time the Model 56 generates data. This is because the Model 56 will only generate data that is compatible with the Model 55.

If you are not using the Model 56, and instead are supplying MIDI data using another device, the LED should prove extremely useful when troubleshooting. Only when the MIDI data conforms to the Model 55's MIDI system-exclusive format will the LED light. Refer to Appendix A, located at the end of this guide, for details on how data must be sent to the Model 55.

Intermittent Audio Connections

Should you experience audio connections that seem to be "flaky" or intermittent, refer to the Technical Notes section of this guide. The ¼-inch 3-conductor phone jacks used on the StudioComm products are of very high quality, conforming to the industry standard EIA RS-453. Some plugs do not meet this standard, specifically in the shape of the tip conductor. In rare cases you may have to replace plugs on interconnecting cables or headphones to remedy an interconnection problem. Switchcraft No. 297 or Neutrik NP3C phone plugs will function correctly.

Clicks in the Audio

As covered in the Configuration section of

the manual, the four stereo line inputs can be configured for -10dBV or $+4\text{dBu}$ operation. Setting an input for -10dBV , while connecting an audio source with a $+4\text{dBu}$ nominal level will lead to distortion (“clipping”) of the signal. In this fault condition the user would hear a harsh “clicking” sounds in the audio, especially when peak levels occur in the program material. To remedy this problem simply use the Model 56 Control Console to configure the input for $+4\text{dBu}$ operation. The distortion will go away and the gain structure of the StudioComm system will be correctly established.

Technical Notes

Talent Amplifier Cable Length

There are no hard and fast rules defining the maximum cable length when connecting Model 35 or Model 38 Talent Amplifiers to the Model 55 Central Controller. The maximum cable length is directly related to the amount of resistance in the connecting cable; the lower the resistance per foot (or meter), the longer the cable can be. (Although cable capacitance affects high frequency performance, resistance is the limiting factor in this case.)

To lay out the facts in grammar-school story problem format: for correct operation, a Model 35 or Model 38 needs to see at least $+20\text{Vdc}$ between pins 1 and 2 of their input connector. The Model 55's talent amplifier output voltage across pins 1 and 2 is $+23\text{Vdc}$, with a maximum current draw of 0.2A (200mA). This difference between the voltage supplied and the voltage required results in a maximum voltage drop of 3V over the interconnect-

ing cables. Since cable is rated in ohms per 1000 feet (or ohms per 1000 meters), you need to know what the maximum cable resistance is. This can be easily calculated by dividing the maximum voltage drop by the maximum current flow: 3V divided by $0.2\text{A} = 15$ ohms. For example, a standard 20 AWG microphone cable is Belden 8412, which has 10.9 ohms resistance per conductor per 1000 feet. Since we're using two conductors to carry the signal (pins 1 and 2) you'd get 21.8 ohms per 1000 feet of microphone cable. With our 15 ohm maximum resistance you'd be able to use 688 feet (210m) of this cable.

By using the numbers provided you can select a cable, and its maximum length, for your application.

Model 55 to Model 56 Cable Length

The Model 56 Control Console generates system-exclusive MIDI messages which are sent to the Model 55 Central Controller using a 5-conductor MIDI-style interconnecting cable. The MIDI signal is carried on two of the five conductors. The three remaining conductors are for common/shield, DC power, and communications audio. The limiting factor in the interconnecting cable's length is the transmission of the MIDI data, which has a rate of 31,250 bits-per-second. The inter-conductor capacitance of the cable attenuates the data, and as the cable length increases the data becomes unusable; the cable serves as a low-pass filter. The MIDI specification calls for a maximum cable length of 50 feet (15.3m), which will work fine connecting the Model 56 to the Model 55. There is really no reason why this length can't be increased, as long as good low-capacitance, shielded cable is utilized. Runs of 100 to 250 feet (30.5 to 76.2m)

are possible using the latest sophisticated cable. Test to ensure that the StudioComm system works correctly with the desired cable length. There are too many variables to give a simple formula—good luck!

¼-Inch Plugs versus EIA RS-453

An incompatibility problem lurks between some ¼-inch 2-conductor and 3-conductor phone plugs and the jacks found on professional audio equipment. While all the plugs seem to “look” the same, some do not comply with the industry standard, called EIA RS-453. This standard defines the physical dimensions, including the shape of the plug’s tip. It seems that some plug manufacturers don’t bother to make the tip comply with the standard. Why is this relevant to you? Because the phone jacks used on the Model 55 Central Controller, Model 35 Talent Amplifier, and Model 38 Talent Amplifier do comply with the standard. They expect to be mated with plugs that also meet the specification.

When interfacing your line inputs, line outputs, or headphones be careful with the plugs you utilize. Should a connection appear “flaky,” sound noisy, or make an intermittent contact, the most likely problem is a non-standard phone plug. Replace the plug if this is the case. You should find that all plugs from Switchcraft or Neutrik will work correctly, specifically Switchcraft No. 297 or Neurtik NP3C. In our experience, headphones are the most likely place to find non-standard plugs—we even found them on some “world-class” headphones that we use in our lab!

Definition of Level—dBu and dBV

Whenever possible, Studio Technologies has opted to use the dBu designation as

it seems to be quite rational. Using dBm was fine when all audio line outputs were terminated with 600 ohm loads. In this way it was easy to say that 0dBm is 1 milliwatt dissipated in the known load (i.e., 0dBm across 600 ohms will measure 0.775V). In contemporary situations an output is rarely terminated with 600 ohms; generally 10k ohms or higher. The dBu designation is better because it refers to dB referenced to 0.775V, with no reference to load impedance. This takes into account today’s audio scene where signals have a low source impedance, and a high input impedance. The dBu designation is becoming the standard for the professional audio industry.

StudioComm equipment is designed to interface with audio signals that have nominal signal levels of -10dBV and $+4\text{dBu}$. You might wonder why dBV came into the picture. Most people don’t realize that equipment that utilizes “ -10 ” levels usually mean -10dBV —substantially different from -10dBu ($-10\text{dBV} = -7.78\text{dBu}$). The dBV designation is simply a different way of measuring signal level and is often used when dealing with portable or consumer audio equipment. The dBV designation refers to dB referenced to 1.0V, rather than dBu which refers to 0.775V.

“Hot” Disconnection of the Model 56 Control Console

Should you need to relocate the Model 56 while your StudioComm system is operating, there is no reason why you can’t disconnect the 5-conductor cable, move the unit, and then connect it again. If the Model 56 is disconnected while it is

operating, the current operating parameters are saved in nonvolatile memory and the Model 55 Central Controller will continue to operate as it did when the link was broken. No clicks, pops, or other noises will occur when the Model 56 is again connected.

The Model 56 will go through its standard power-up sequence, send a message to reset power-up defaults, then send the operating parameters as stored in its memory. You may notice a brief interval of silence while the Model 55 responds to the reset defaults message.

Control Room Mono Function

Many arguments were had while designing the control room monaural function. Was the function supposed to be a true mono function, sending the sum of left and right to a separate mono control room output? Was mono to be the sum of left and right sent to both left and right channels? What about level build up with phase coherent signals that are in both the left and right channels? After much head scratching it was realized that the mono function that most people are accustomed to is really a means of observing the character of a stereo mix, and not a “true” mono function. To observe the stereo image of a mix you need to sum the left and right signals, drop the level of the sum by 6dB, and send the result out the left and right outputs. This is what virtually all recording consoles implement, and is what the StudioComm does, too!

Talent Amplifier Mono Function

The Model 35 and Model 38 Talent Amplifiers each contain a monaural switch. The mono function sums the left and right input signals, drops the level of the sum by 6dB,

and sends the sum to both the left and right outputs. This is consistent with the mono methodology discussed in the previous paragraph. Please refer to that note for details.

Input Level and the Talent Amplifiers

Optimal performance of the Model 35 and Model 38 Talent Amplifiers depend on the headphone source signal levels being at approximately the nominal input level, either -10dBV or $+4\text{dBu}$, depending on the configuration. The headphone volume is adjusted only by the level controls on the talent amplifiers. If the selected headphone source signal level is significantly less than nominal, the talent amplifier will simply not be able to create the maximum volume in the headphones. While there is some gain in the talent amplifiers, optimal performance still requires an input close to nominal.

The Model 38 Talent Amplifier can also exhibit reduced performance if the level of the headphone source is significantly “hotter” than nominal. The entire system has plenty of headroom, but maintaining proper signal levels, as usual, is important. If the source selected for headphones has an average level that is excessive, a small amount of bleed-through can be heard with the Model 38’s cue mix level control set fully counterclockwise. Instead of having no sound in the phones, a bit of sound can be heard. This is not a design problem; the Model 38 has a sensitive preamplifier section which doesn’t like excessive excursions in the left channel modulation of the $+23\text{Vdc}$ signal. The Model 38’s power supply can reject the left channel modulation within the design parameters, creating a clean reference voltage for the stereo preamplifier. Modulation levels outside

the design parameters show up in the reference voltage!

Communication Switch Noise

During field trials of the StudioComm components one item came up for discussion concerning “thumps” in the communications functions. A brief discussion may be useful. Electrically the Model 55 and Model 56 electronics that support the communications functions are quite quiet, not adding appreciable “clicks, pops, or thumps.” Software time delays are even added to minimize noise when a button is pressed. Mechanical noise being picked up by the Model 56’s microphone can be an issue. If the talk to phones or slate buttons are pushed using a relatively light touch no objectionable noise will be generated; pressing the switches with “gusto” will cause mechanical noise to be transferred into the microphone. While the Model 56’s microphone is of good quality, shock mounting it was not possible using a cost-effective method. The fact that the Model 56 is physically small and the buttons must be relatively close to the microphone adds to the difficulty. (Note that most all recording consoles, both small and large, share this condition.) So in conclusion, use a light touch on the buttons and everyone should stay reasonably happy!

Power Amplifier Input Sensitivity

Optimum StudioComm performance is obtained when the input sensitivity of the control room power amplifier is adjusted to match the Model 55’s output level. With normal, but loud, listening levels you should find the level potentiometer on the Model 56 to be set to about 2 o’clock. If you find that you don’t have to turn up the

Model 56’s control that high, reduce the input sensitivity of the power amplifier until you get to the 2 o’clock position. Most power amplifiers have controls on their inputs to allow easy adjustment of the input sensitivity.

Control Room Output Transient Protection

Unique to the Model 55 Central Controller is a power up/power down transient protection feature. It limits the chance of damage to the control room loudspeakers during the time when AC mains voltage is connected, disconnected, or has significantly changed from nominal. A combination of hardware and software is used to monitor one of the power supply “rails.” Until the rail voltage exceeds 81% of its nominal value, an electromechanical relay maintains a short circuit condition on the control room output. After a one-second delay the relay is released to function normally. Whenever the rail voltage drops below 79% of its nominal value, the relay immediately goes to its mute state. During testing it was found that upon power up the control room output remained very quiet; during power down a moderate “tick” was the worst that was heard.

Meter Output Calibration

At the factory a +4dBu signal is applied to input 1, input 1 is selected as the control room source, and the meter output is monitored with an Audio Precision System One (set for 100k ohm input impedance). Trim potentiometers, located on the Model 55’s printed circuit board, are set to give an output level of +4dBu. In this way input 1 becomes the “accurate” input when a user views the meters. As input 1 serves as the “calibrated” input for metering, it

may impact which source you choose to connect to it.

While a “precision” device, the Model 55 relies upon 1%-tolerance resistors for signal level integrity. “Perfect” tracking of the input levels, vis-a-vis the four inputs, is simply not possible; deviations of up to $\pm 0.5\text{dB}$ are considered normal. (In most cases, the human ear is not aware of level variations this small, especially when comparing different program sources.)
Conclusion: The same input signal connected to multiple Model 55 input channels may display slightly different levels on the meters.

Direction Connection to Mechanical Meters

As shipped from the factory, the meter output is not intended to directly drive VU- or PPM-type mechanical meter movements. These meters generally require a series current-limiting resistor, such as the 3.6k ohm resistors commonly used with VU-type meters. Provision has been made on the Model 55 printed circuit board to allow series resistors to be inserted. However, 0 ohm resistors are inserted at the factory. Refer to the Model 55 schematic diagram, contained in the Service Guide, for details.

Maximum Output Attenuation

The meter output requires that the input source(s) remain connected through the Model 55’s switching circuitry at all times, even when the level control is set to the fully counterclockwise position. Instead of fully muting the output, the control room level is attenuated by approximately 73dB, which is the maximum supported by the voltage-controlled amplifiers (VCAs). During normal operation this should not

prove to be a problem. However, it is possible that someone connecting a very “hot” signal to the Model 55, and selected it as the control room source, might perceive that the circuitry “bleeds” signal even when the control room level pot is turned “all the way” down. This is due to the fact that the input signal is being attenuated by 73dB, rather than being fully “muted.”

Specifications

Model 55 Central Controller

Mounting

One space in a standard 19-inch (48.3cm) rack

AC Mains Requirement

100, 120, or 220/240V, $\pm 10\%$, factory configured, 50/60Hz, 100-120V 0.4A maximum, 220/240V 0.2A maximum

Fusing

Qty: 1

Type: 5 x 20mm time lag (Littelfuse 218-series or equivalent)

Rating: 0.400A for 100 and 120V mains power, 0.200A for 220/240V mains power

Connectors

Audio Inputs and Outputs: dual, ¼-inch, 3-conductor phone jacks, gold-plated contacts (Manufactured by Neutrik). Mates with all plugs specified by EIA RS-453.

Talent Amplifier Output: 3-pin XLR-type, male (Neutrik)

Control Console/MIDI In: 5-pin DIN-type, female

AC Mains: standard 3-blade plug, meets IEC 320 specifications

Audio Inputs

Qty: 4, stereo (separate left and right input connectors)

Type: electronically balanced, direct coupled, compatible with balanced or unbalanced signals

Impedance: 24k ohms

Nominal Input Level: -10dBV or $+4\text{dBu}$, each input individually software configurable

Common Mode Rejection: 100dB @ DC and 60Hz, 70dB @ 20kHz, 62dB @ 40kHz (typical)

Control Room Output

Qty: 1, stereo (separate left and right output connectors)

Type: electronically balanced, intended to drive loads of 600 ohms or greater, balanced or unbalanced

Output Level (input source at nominal level): -69dBu at 0% rotation (fully counterclockwise), -58dBu at 25% rotation, -37dBu at 50% rotation, -17dBu at 75% rotation, $+4\text{dBu}$ at 100% rotation (fully clockwise)

Maximum Output Level: $+27\text{dBu}$ into 10k ohms, $+26\text{dBu}$ into 600 ohms

Frequency Response: 10Hz-40kHz $+0/-0.5\text{dB}$ (down 1dB @ 80kHz)

Distortion (THD+N): 0.02% (measured at $+4\text{dBu}$ input, $+4\text{dBu}$ output)

S/N Ratio: 87dB (20Hz-20kHz)

Dub Output

Qty: 1, stereo (separate left and right output connectors)

Type: electronically balanced, intended to drive loads of 600 ohms or greater, balanced or unbalanced

Nominal Output Level: -10dBV or $+4\text{dBu}$, software configurable

Maximum Output Level: $+27\text{dBu}$ into 10k ohms, $+26\text{dBu}$ into 600 ohms

Frequency Response: 10Hz-40kHz $+0/-0.5\text{dB}$ (down 1dB @ 70kHz)

Distortion (THD+N): 0.004% (measured at $+4\text{dBu}$ input, $+4\text{dBu}$ output)

S/N Ratio: 92dB (20Hz-20kHz)

Meter Output

Qty: 1, stereo (separate left and right output connectors)

Type: unbalanced, intended to drive loads of 2k ohms or greater

Nominal Output Level: $+4\text{dBu}$

Maximum Output Level: $+21\text{dBu}$ into 10k ohms

Frequency Response: 10Hz-40kHz $+0/-0.5\text{dB}$ (down 1dB @ 70kHz)

Distortion (THD+N): 0.004% (measured at $+4\text{dBu}$ input, $+4\text{dBu}$ output)

S/N Ratio: 92dB (20Hz-20kHz)

Talent Amplifier Output

Application: provides power and audio signals for up to 4 Model 35 or Model 38 Talent Amplifiers. The output connector (3-pin XLR-type, male) has common on pin 1, +23Vdc modulated with left channel audio at -10dBu on pin 2, and right channel audio at -10dBu on pin 3. Maximum output current 200mA (nominal).

LED Indicators

Qty: 3, power present, over current, and input data present

Dimensions (Overall)

19.00 inches wide (48.3cm)
1.72 inches high (4.4cm)
8.75 inches deep (22.2cm)
(1 standard rack space)

Weight

8.5 pounds (3.9kg)

Model 56 Control Console

Mounting

Desktop. Provision for stand mounting provided.

Power Requirements

15Vdc filtered and regulated, 75mA maximum, provided by Model 55 Central Controller

Connectors

To Model 55 Central Controller: 5-pin DIN-type, female

Internal Microphone

Type: electret condenser

Frequency Response: 3dB roll off at 105Hz

Dimensions (Overall)

7.2 inches wide (18.3cm)
2.2 inches high (5.6cm)
5.4 inches deep (13.7cm)

Weight

1.7 pounds (0.8kg)

Model 35 Talent Amplifier

Mounting

Desktop. Provision for stand mounting available as option.

Power Requirements

+20-32Vdc (modulated with left channel audio), provided by Model 55 Central Controller

Power Present LED

Red LED indicates presence of operating power

Connectors

Input (from Model 55): 3-pin XLR-type, female (Neutrik)

Loop Thru: 3-pin XLR-type, male, connected in parallel with input connector (Neutrik)

Headphone Outputs: 2, ¼-inch, 3-conductor (stereo) phone jacks, gold-plated contacts (Neutrik)

Headphone Output

Qty: 1, feeds two headphone jacks

Load: intended for connection to one or two pairs of headphones with total impedance of 75 ohms or greater

Output Level: user adjustable

Maximum Output Voltage: 16V peak-to-peak into 150 ohms @ 1% THD+Noise, 400Hz

Distortion (THD+N): 0.03%

Frequency Response: 20Hz-20kHz ±0.5dB

Dimensions (Overall)

4.2 inches wide (10.7cm)
2.0 inches high (5.1cm)
5.3 inches deep (13.5cm)

Weight

0.8 pounds (0.4kg)

Model 38 Talent Amplifier

Mounting

Desktop. Provision for stand mounting provided.

Power Requirements

+20-32Vdc (modulated with left channel audio), provided by Model 55 Central Controller

Power Present LED

Red LED indicates presence of operating power

Connectors

Cue Mix Input (from Model 55): 3-pin XLR-type, female (Neutrik)

Cue Mix Input Loop Thru: 3-pin XLR-type male, connected in parallel with input connector (Neutrik)

Talent Input (Left In/Mono and Right In): 3-pin XLR-type, female (Neutrik)

Talent Input Loop Thru: 3-pin XLR-type male, connected in parallel with input connectors (Neutrik)

Headphone Outputs: 2, ¼-inch, 3-conductor (stereo) phone jacks, gold-plated contacts (Neutrik)

Cue Mix Input

Intended for connection only with Model 55 Central Controller

Talent Input

Qty: 1, stereo or mono, switch selectable

Type: electronically balanced, capacitor coupled, input impedance 20k ohms

Input level: switch selectable for microphone or line-level signals. Expected signal level: Mic position -40 to -60dBu, Line position -10 to +10dBu.

Headphone Output

Qty: 1, feeds two headphone jacks

Load: intended for connection to one or two pairs of headphones with total impedance of 75 ohms or greater

Output Level: user adjustable

Maximum Output Voltage: 16V peak-to-peak into 150 ohms @ 1% THD+Noise, 400Hz

Distortion (THD+N): 0.1%

Frequency Response: 20Hz-20kHz ±0.5dB

Dimensions (Overall)

8.0 inches wide (20.3cm)

2.0 inches high (5.1cm)

5.4 inches deep (13.7cm)

Weight

1.5 pounds (0.7kg)

Model 70 Interface

Power Requirements

+20-32Vdc (modulated with left channel audio), provided by Model 55 Central Controller

Power Present LED

Red LED indicates presence of operating power

Connectors

Input (from Model 55): 3-pin XLR-type, female (Neutrik)

Loop Thru: 3-pin XLR-type, male, connected in parallel with input connector (Neutrik)

Left and Right Line Outputs: 3-pin XLR-type, male

Line Output

Qty: 1, stereo

Type: electronically balanced, intended to drive loads of 600 ohms or greater, balanced or unbalanced

Nominal Output Level: +4dBu

Maximum Output Level: +20dBu into 10k ohms, +19dBu into 600 ohms

Frequency Response: 20Hz-20kHz +0/-0.5dB

Distortion (THD+N): 0.02%

Dimensions (Overall)

4.2 inches wide (10.7cm)

2.0 inches high (5.1cm)

5.3 inches deep (13.5cm)

Weight

0.8 pounds (0.4kg)

Specifications and information contained in this User Guide subject to change without notice.

Appendix A

Controlling the Model 55

The Model 55 Central Controller uses MIDI system-exclusive messages to control all functions. The Model 56 Control Console is programmed to generate a subset of what the Model 55 is capable of doing. By using standard MIDI messages, the Model 55 can be used for a wide range of special applications. Any device that can be programmed to send system-exclusive MIDI messages can be used to control the Model 55.

Note that the 5-pin connector on the Model 55's back panel is wired somewhat differently from a standard MIDI input. While pins 4 and 5 meet the MIDI standard, the three remaining pins are implemented for use by the Model 56. Pin 1 supplies +15Vdc power, pin 2 is shield (ground), and pin 3 is communications audio input.

If you're connecting your own controller, such as a computer's MIDI interface, you might be concerned about the DC power on pin 1. Because the MIDI standard doesn't use this pin, it is highly unlikely that it will be connected inside your controller, so there's little chance of the DC causing damage. To be safe, you can use a MIDI cable with only two or three wires implemented.

The following pages provide a detailed list of all Model 55 system-exclusive MIDI messages.

Model 55 Central Controller

MIDI Implementation Chart

Function		Transmitted	Recognized	Remarks
Basic Channel	Default Channel	Not Applicable	Not Applicable	
Mode	Default Messages Altered	Not Applicable	Not Applicable	
Note Number	True Voice	Not Applicable	Not Applicable	
Velocity	Note ON Note OFF	Not Applicable	Not Applicable	
After Touch	Key's Ch's	Not Applicable	Not Applicable	
Pitch Bender		Not Applicable	Not Applicable	
Control Change		X	X	
Prog Change	True #	X	X	
System Exclusive		X	O	Refer to following pages
System Common	Song Pos	X	X	
	Song Sel	X	X	
	Tune	X	X	
System Real Time	Clock	X	X	
	Commands	X	X	
Aux Messages	Local ON/OFF	X	X	
	All Notes Off	X	X	
	Active Sense	X	X	
	Reset	X	X	
Notes				

Mode 1: OMNI ON, POLY
Mode 3: OMNI OFF, POLY

Mode 2: OMNI ON, MONO
Mode 4: OMNI OFF, MONO

O: Yes
X: No

Model 55 Central Controller

MIDI Messages to be Acted Upon

General Notes:

1. All MIDI messages to be acted upon are system-exclusive type (F0H). No channel mode, system common, or system real time messages are utilized.
2. Studio Technologies, Inc. manufacturer's ID number is 00H 00H 56H.
3. The Model 55's product device ID number is 02H.

Function: Reset to Power Up Default Configuration

Byte	Value	Description
1	F0H	System-Exclusive Message
2	00H	1st Byte of Studio Tech ID
3	00H	2nd Byte of Studio Tech ID
4	56H	3rd Byte of Studio Tech ID
5	02H	Product ID (Model 55)
6	00H	Function: Restore Power Up Default Configuration
7	F7H	EOX, End of System Exclusive

Action taken after Model 55 receives MIDI message:

1. Set control room level to minimum.
2. Set control room source 1 to no input.
3. Set control room source 2 to no input.
4. Set headphone source to no input.
5. Set dub source to no input.
6. Set control room output to off.
7. Set mono to off (stereo mode).
8. Set all input levels to +4.
9. Set dub output level to +4.
10. Set dim to normal, non-dim
11. Set dim level to 20dB.
12. Set talk to headphones to off.
13. Set slate to off.

Function: Input Level

Byte	Value	Description
1	F0H	System-Exclusive Message
2	00H	1st Byte of Studio Tech ID
3	00H	2nd Byte of Studio Tech ID
4	56H	3rd Byte of Studio Tech ID
5	02H	Product ID (Model 55)
6	01H	Function: Input Level
7	0nH	Input Channel, range 1-4, 1=input 1, 2=input 2, etc.
8	0nH	Input Level, range 0-1, 0=-10, 1=+4
9	F7H	EOX, End of System Exclusive

Function: Dub Output Level

Byte	Value	Description
1	F0H	System-Exclusive Message
2	00H	1st Byte of Studio Tech ID
3	00H	2nd Byte of Studio Tech ID
4	56H	3rd Byte of Studio Tech ID
5	02H	Product ID (Model 55)
6	02H	Function: Output Level
7	0nH	Output Channel, range 1, 1=dub out
8	0nH	Output Level, range 0-1, 0=-10, 1=+4
9	F7H	EOX, End of System Exclusive

Function: Control Room Source 1

Byte	Value	Description
1	F0H	System-Exclusive Message
2	00H	1st Byte of Studio Tech ID
3	00H	2nd Byte of Studio Tech ID
4	56H	3rd Byte of Studio Tech ID
5	02H	Product ID (Model 55)
6	03H	Function: Control Room Source 1
7	mnH	Source Selected, m range 0-2: 0=stereo, 1=left only, 2=right only; n range 0-4: 0=no input, 1=input 1, 2=input 2, etc.
8	F7H	EOX, End of System Exclusive

Function: Control Room Source 2

Byte	Value	Description
1	F0H	System-Exclusive Message
2	00H	1st Byte of Studio Tech ID
3	00H	2nd Byte of Studio Tech ID
4	56H	3rd Byte of Studio Tech ID
5	02H	Product ID (Model 55)
6	04H	Function: Control Room Source 2
7	mnH	Source Selected, m range 0-2: 0=stereo, 1=left only, 2=right only; n range 0-4: 0=no input, 1=input 1, 2=input 2, etc.
8	F7H	EOX, End of System Exclusive

Function: Headphone Source

Byte	Value	Description
1	F0H	System-Exclusive Message
2	00H	1st Byte of Studio Tech ID
3	00H	2nd Byte of Studio Tech ID
4	56H	3rd Byte of Studio Tech ID
5	02H	Product ID (Model 55)
6	05H	Function: Headphone Source
7	mnH	Source Selected, m range 0-2: 0=stereo, 1=left only, 2=right only; n range 0-4: 0=no input, 1=input 1, 2=input 2, etc.
8	F7H	EOX, End of System Exclusive

Function: Dub Source

Byte	Value	Description
1	F0H	System-Exclusive Message
2	00H	1st Byte of Studio Tech ID
3	00H	2nd Byte of Studio Tech ID
4	56H	3rd Byte of Studio Tech ID
5	02H	Product ID (Model 55)
6	06H	Function: Dub Source
7	mnH	Source Selected, m range 0-2: 0=stereo, 1=left only, 2=right only; n range 0-4: 0=no input, 1=input 1, 2=input 2, etc.
8	F7H	EOX, End of System Exclusive

Function: Control Room Level

Byte	Value	Description
1	F0H	System-Exclusive Message
2	00H	1st Byte of Studio Tech ID
3	00H	2nd Byte of Studio Tech ID
4	56H	3rd Byte of Studio Tech ID
5	02H	Product ID (Model 55)
6	07H	Function: Control Room Level
7	0nH	Level, MSB, range 0-3, see notes
8	nnH	Level, LSB, range 00-7F, see notes
9	F7H	EOX, End of System Exclusive

Notes:

MSB=0 allows LSB to control lower 128 level steps, MSB=1 allows LSB field to control upper 128 level steps. During operation MSB=0/LSB=00 gives minimum output level (maximum attenuation), MSB=1/LSB=7F gives maximum output level.

MSB=2 places function in reduced precision mode, where LSB=00 gives minimum output level (maximum attenuation), LSB=7F is maximum output.

MSB=3 places function in reduced precision, reverse range mode, where LSB=7F gives minimum output level (maximum attenuation), LSB=00 is maximum output.

Function: Control Room Output Select

Byte	Value	Description
1	F0H	System-Exclusive Message
2	00H	1st Byte of Studio Tech ID
3	00H	2nd Byte of Studio Tech ID
4	56H	3rd Byte of Studio Tech ID
5	02H	Product ID (Model 55)
6	09H	Function: Control Room Output Select
7	nnH	Output Selected, Range 00-11: <u>L Ch.</u> <u>R Ch.</u> <u>Action</u> 0 0 No Output 1 0 Left Only 0 1 Right Only 1 1 Left and Right
8	F7H	EOX, End of System Exclusive

Function: Control Room Mono/Stereo Select

Byte	Value	Description
1	F0H	System-Exclusive Message
2	00H	1st Byte of Studio Tech ID
3	00H	2nd Byte of Studio Tech ID
4	56H	3rd Byte of Studio Tech ID
5	02H	Product ID (Model 55)
6	0AH	Function: Control Room Mono
7	0nH	Output Selected, Range 0-1, 0=stereo, 1=mono
8	F7H	EOX, End of System Exclusive

Function: Control Room Dim

Byte	Value	Description
1	F0H	System-Exclusive Message
2	00H	1st Byte of Studio Tech ID
3	00H	2nd Byte of Studio Tech ID
4	56H	3rd Byte of Studio Tech ID
5	02H	Product ID (Model 55)
6	0BH	Function: Control Room Dim
7	0nH	Status, Range 0-1, 0=No Dim, 1=Dim
8	F7H	EOX, End of System Exclusive

Function: Talk to Headphones

Byte	Value	Description
1	F0H	System-Exclusive Message
2	00H	1st Byte of Studio Tech ID
3	00H	2nd Byte of Studio Tech ID
4	56H	3rd Byte of Studio Tech ID
5	02H	Product ID (Model 55)
6	0EH	Function: Talk to Headphones
7	0nH	Status, Range 0-2, 0=no talk to headphones, 1=talk to headphones (interrupt), 2=talk to headphones (add)
8	0nH	Level, range 1-8, 8 is loudest
9	F7H	EOX, End of System Exclusive

Function: Slate

Byte	Value	Description
1	F0H	System-Exclusive Message
2	00H	1st Byte of Studio Tech ID
3	00H	2nd Byte of Studio Tech ID
4	56H	3rd Byte of Studio Tech ID
5	02H	Product ID (Model 55)
6	0FH	Function: Slate
7	0nH	Status, Valid Values 0, 1, and 3, 0=no slate, 1=slate to dub output, 3=slate to dub and headphone output
8	0nH	Level, range 1-8, 8 is loudest
9	F7H	EOX, End of System Exclusive

Function: Set Dim Level

Byte	Value	Description
1	F0H	System-Exclusive Message
2	00H	1st Byte of Studio Tech ID
3	00H	2nd Byte of Studio Tech ID
4	56H	3rd Byte of Studio Tech ID
5	02H	Product ID (Model 55)
6	10H	Function: Set Dim Level
7	0nH	Status, Range 0-5: 0=full mute (approx. 70dB) 1=30dB dim 2=25dB dim 3=20dB dim 4=15dB dim 5=10dB dim
8	F7H	EOX, End of System Exclusive

LINE INPUT 1*
(-10dBV or +4dBu)

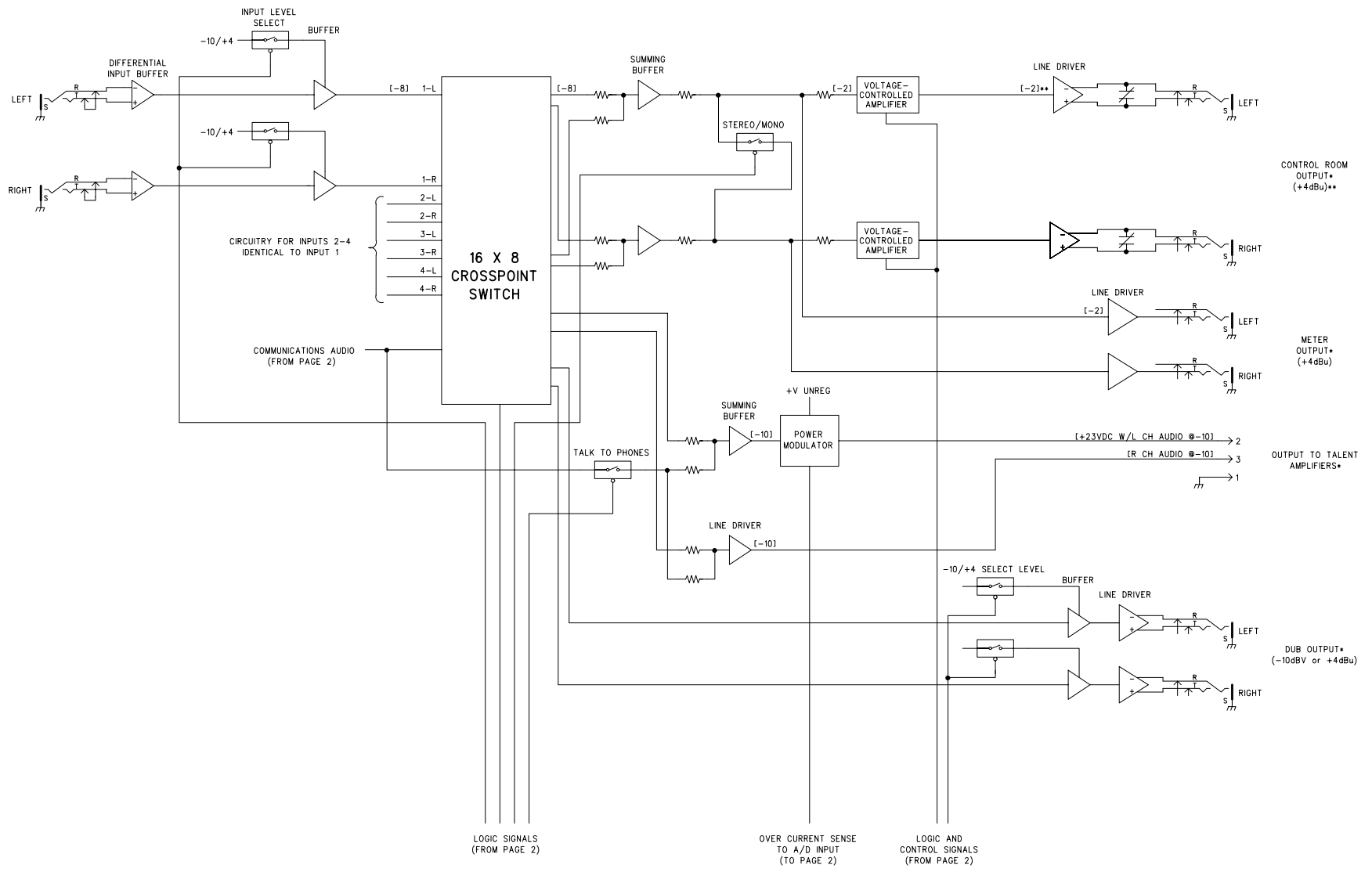

FOR SERIAL NUMBERS 00151 AND LATER

* LOCATED ON BACK PANEL
** W/LEVEL CONTROL AT MAXIMUM
(NOMINAL LEVEL IN dBu)

STUDIO TECHNOLOGIES, INC.		
MODEL 55 CENTRAL CONTROLLER BLOCK DIAGRAM		
DRAWING NO.	DATE	PAGE
30348	12/03/96	01 OF 02

M55BD_B

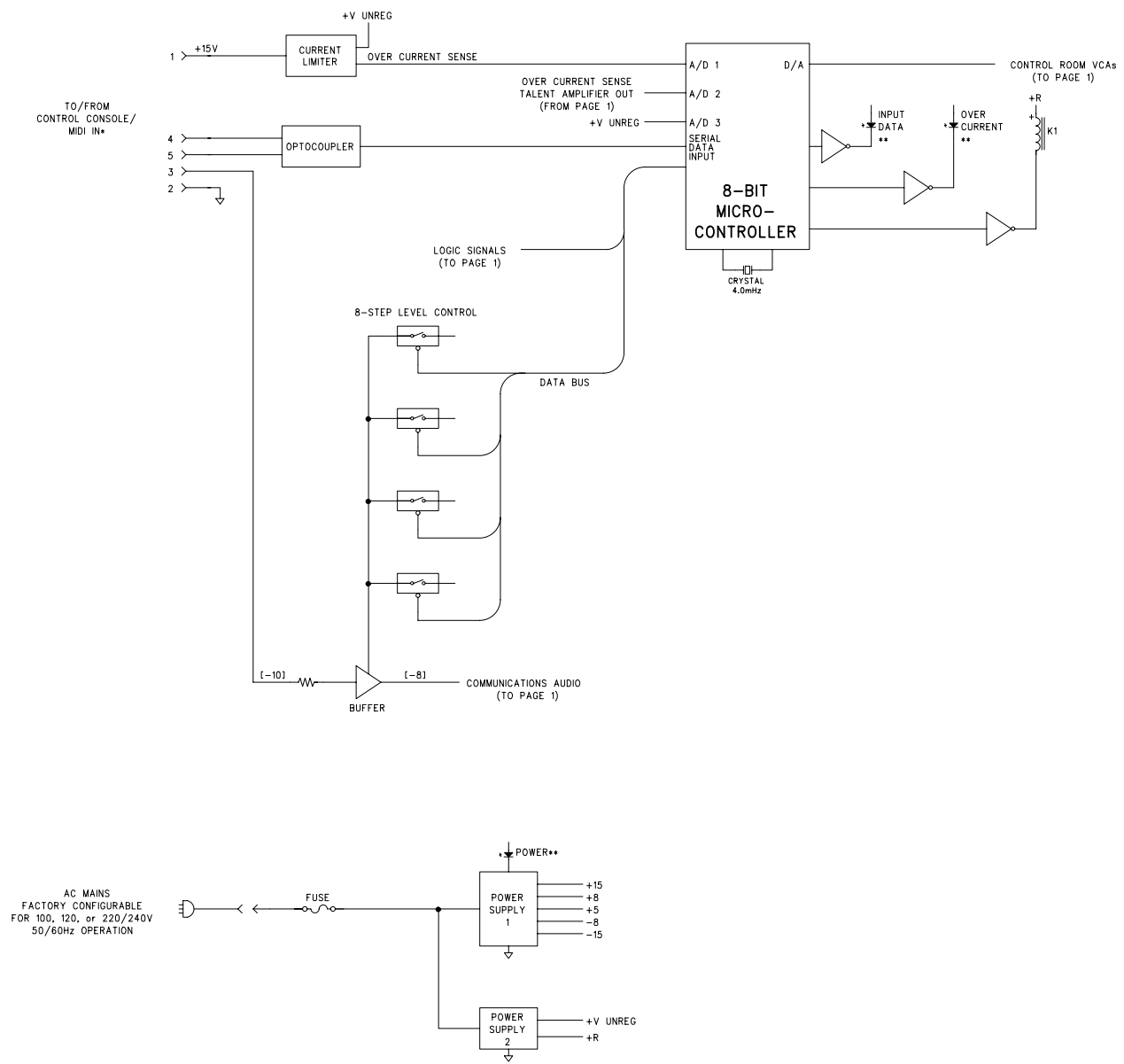

* LOCATED ON BACK PANEL
 ** LOCATED ON FRONT PANEL (NOMINAL LEVEL IN dBu)

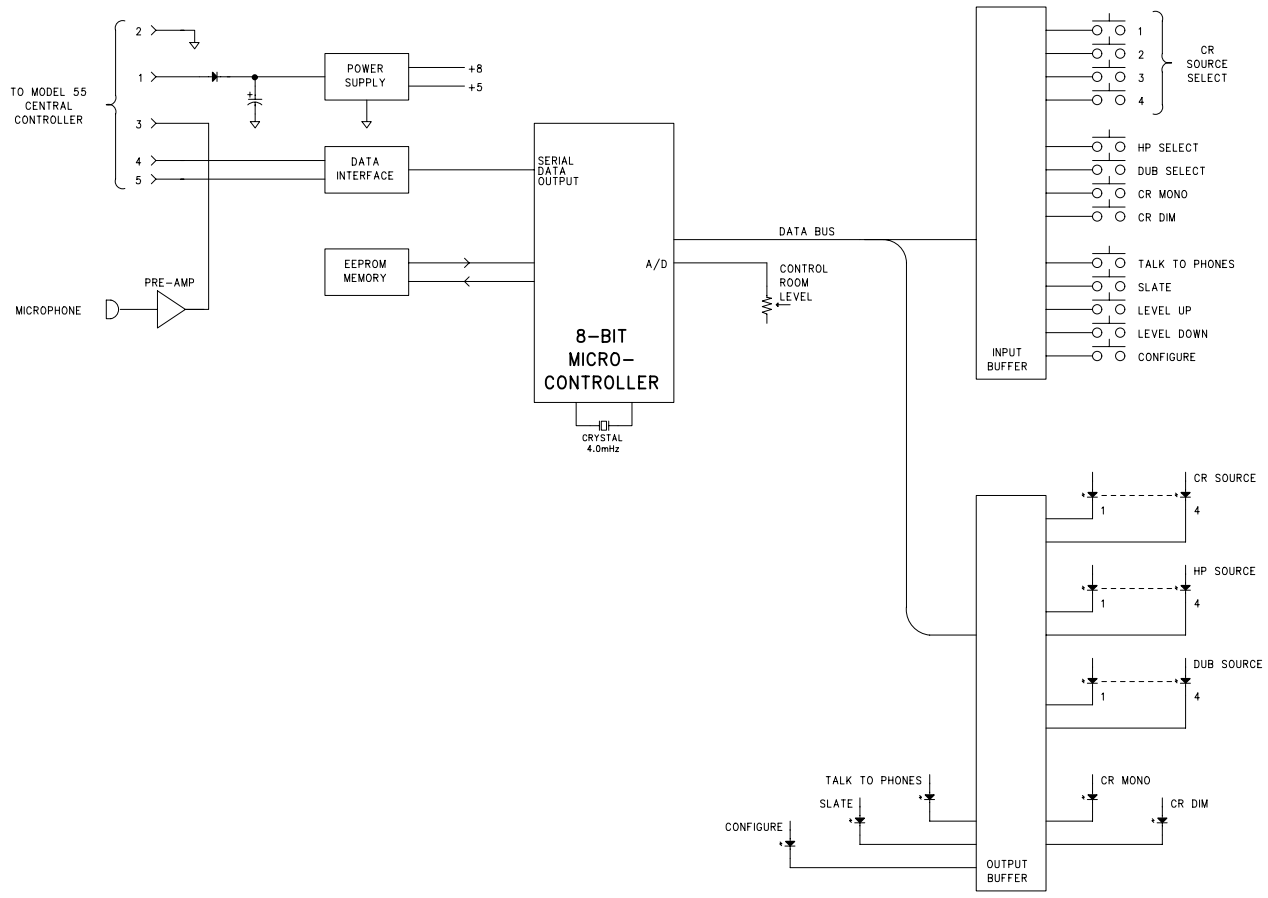

M56BD_B

STUDIO TECHNOLOGIES, INC.		
MODEL 56 CONTROL CONSOLE BLOCK DIAGRAM		
DRAWING NO. 30351	DATE 12/03/96	PAGE 01 OF 01

MODEL 35 TALENT AMPLIFIER

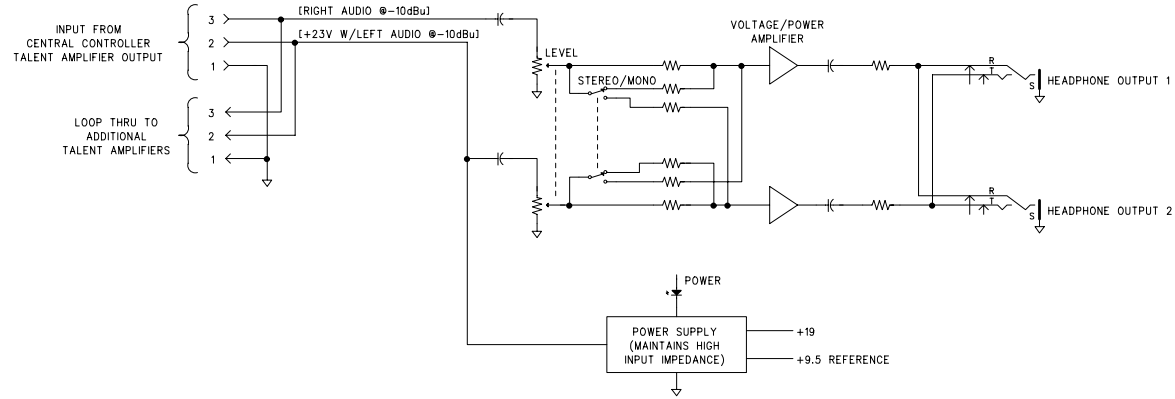

MODEL 38 TALENT AMPLIFIER

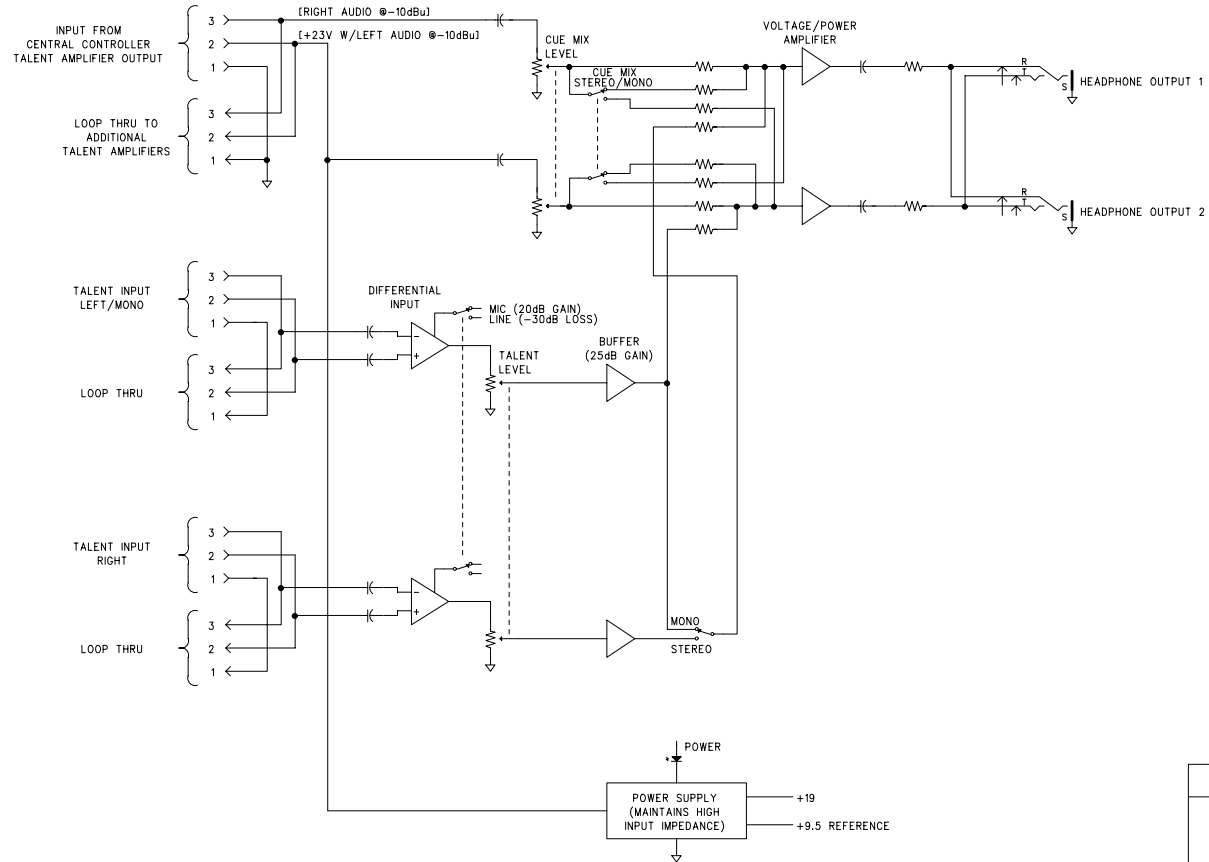

M3538BDB

STUDIO TECHNOLOGIES, INC.		
MODEL 35 AND MODEL 38 TALENT AMPLIFIERS BLOCK DIAGRAM		
DRAWING NO. 30312	DATE 07/27/93	PAGE 01 OF 01

MODEL 70 INTERFACE

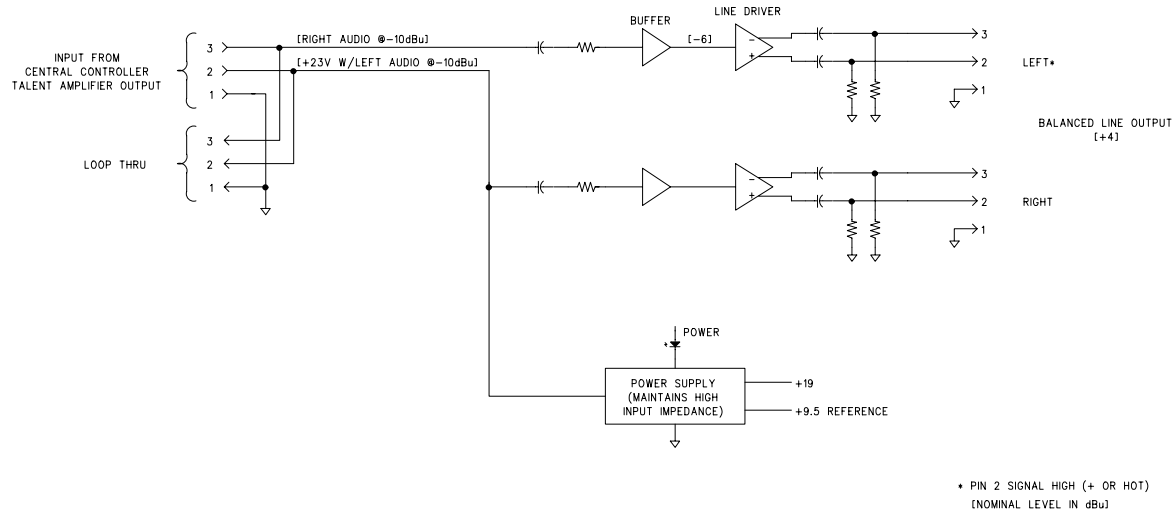

MODEL 71 MIC MODULE

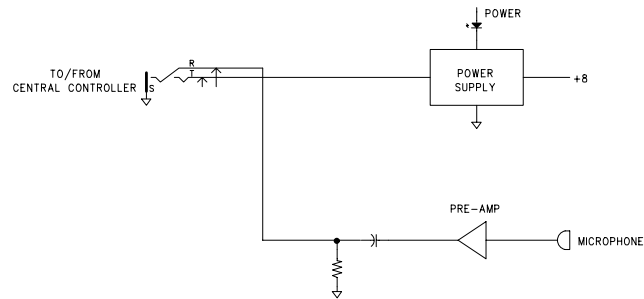

M7071BDA

STUDIO TECHNOLOGIES, INC.		
MODEL 70 INTERFACE MODEL 71 MIC MODULE BLOCK DIAGRAM		
DRAWING NO. 30458	DATE 09/01/93	PAGE 01 OF 01